



Turn to the Experts.™

Installation, Start–Up, and Operating Instructions

NOTE: Read the entire instruction manual before starting the installation.

TABLE OF CONTENTS

	PAGE
SAFETY CONSIDERATIONS	1
INTRODUCTION	3
LOCATION	3
Step 1 — General	3
Step 2 — Location Relative to Cooling Equipment	4
INSTALLATION	4
Step 1 — Air for Combustion and Ventilation	4
Step 2 — General	4
Step 3 — Ductwork Recommendations	5
Step 4 — Venting	8
Step 5 — Factory-Built Chimneys	8
Step 6 — Oil Burner	8
Step 7 — Oil Connections	8
Step 8 — Barometric Draft Control	9
Step 9 — Blocked Vent Shut-Off (BVSO) For Chimney Venting	9
Step 10 — Electrical Connections	11
Step 11 — Horizontal or Downflow Installation	13
START-UP, ADJUSTMENT, AND SAFETY CHECKOUT ..	13
Step 1 — Operational Checkout	13
Step 2 — Combustion Check	13
Step 3 — Fan Adjustment Check	14
Step 4 — Limit-Control Check	14
Step 5 — For Year-Round Air Conditioning	14
Step 6 — Heating	14
Step 7 — Cooling	14
Step 8 — Constant Blower Switch	14
CARE AND MAINTENANCE	15
Step 1 — General	15
Step 2 — Oil Burner	15
Step 3 — Heat Exchanger and Flue Pipe	15
Step 4 — Blocked Vent Shut-Off (BVSO) Cleaning	16
Step 5 — Blower Removal	16



Fig. 1 - 58CMR Multipoise Oil Furnace

A06625

SAFETY CONSIDERATIONS

Recognize safety information. This is the safety-alert symbol . When you see this symbol on the furnace and in instructions or manuals, be alert to the potential for personal injury.

Understand the signal words DANGER, WARNING, and CAUTION. These words are used with the safety-alert symbol. DANGER identifies the most serious hazards which **will** result in severe personal injury or death. WARNING signifies a hazard which **could** result in personal injury or death. CAUTION is used to identify unsafe practices which **may** result in minor personal injury or product and property damage. NOTE is used to highlight suggestions which **will** result in enhanced installation, reliability, or operation.



B140.0–B140.4–UL727
157971

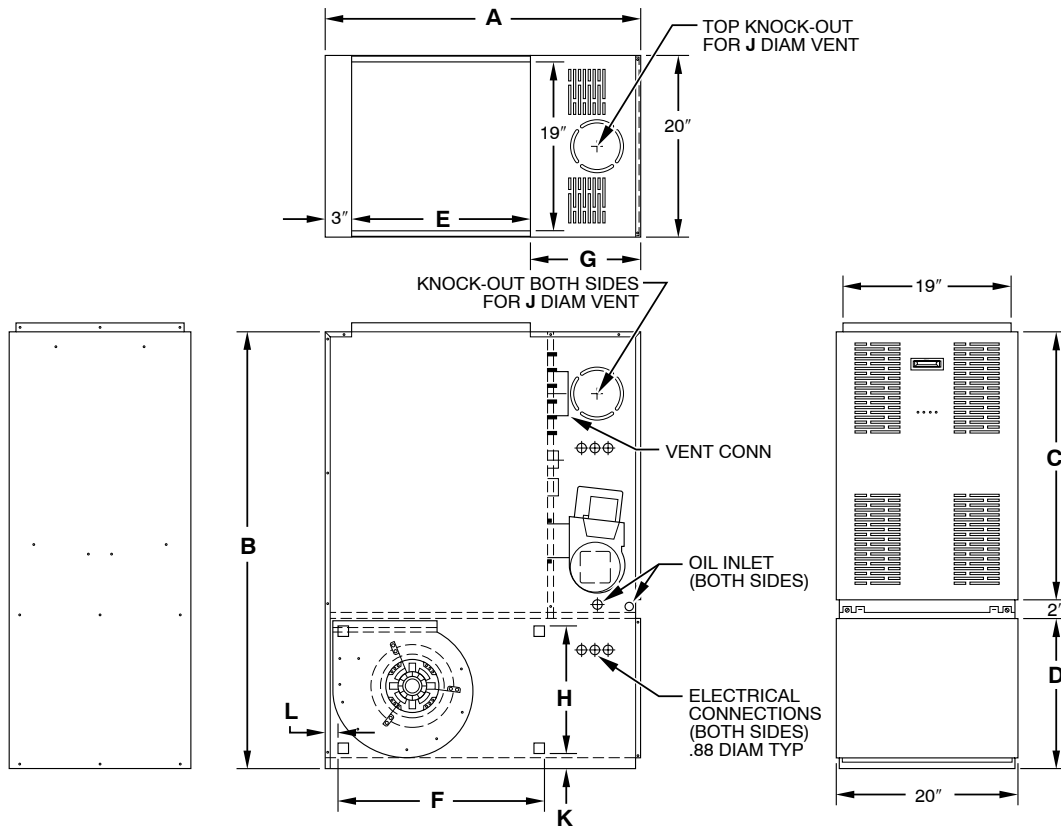

Fig. 2 - Dimensional Drawing
Dimensions (in.)

A98037

UNIT SIZE	A	B	C	D	E	F	G	H	J	K	L
105-12	35	48-3/4	30-1/4	16-5/8	20	22	12	14	5	1-1/2	1-3/4
120-20	39-1/2	53	32-1/4	18-3/4	24	28	12-5/16	16	6	1-5/8	1-1/2

⚠ WARNING

FIRE, EXPLOSION, ELECTRICAL SHOCK HAZARD

Failure to follow this warning could result in personal injury, death, and/or property damage.

These instructions are intended to be used by qualified personnel who have been trained in installing this type of furnace.

⚠ WARNING

FIRE, EXPLOSION HAZARD

Failure to follow this warning could result in personal injury, death, and/or property damage.

Do not store or use gasoline or other flammable vapors and liquids in the vicinity of this or any other appliance. Do not attempt to start the burner when excess oil has accumulated, when the furnace is full of vapor, or when the combustion chamber is very hot.

For use with grade 1 or 2 fuel oil. Do not use gasoline, crankcase oil, or any oil containing gasoline!

Never burn garbage or paper in the heating system and never leave rags, paper, or any flammable items around the unit.

All local and national code requirements governing installation of oil burning equipment, wiring, and flue connections must be followed. Some of the codes (issued by the Canadian Standards Association, the National Fire Protection Agency, and/or the American National Standards Institute) that may be applicable are:

ANSI/NFPA 31: INSTALLATION OF OIL BURNING EQUIPMENT

ANSI/NFPA 211: CHIMNEYS, FIREPLACES, VENTS, AND SOLID FUEL BURNING APPLIANCES

ANSI/NFPA 90B: WARM AIR HEATING AND AIR CONDITIONING SYSTEMS

ANSI/NFPA 70: NATIONAL ELECTRIC CODE

CSA B139: INSTALLATION CODE FOR OIL BURNING EQUIPMENT

CSA C22.1: CANADIAN ELECTRICAL CODE

Only the latest issues of these codes should be used, and are available from either The National Fire Protection Agency, Batterymarch Park, Quincy, MA 02269 or The Canadian Standards Association, 178 Rexdale Blvd., Rexdale, Ontario M9W 1R3.

This furnace is designed for continuous return-air minimum temperature of 60°F/16°C db or intermittent operation down to 55°F/13°C db, such as when used with a night setback thermostat. Return-air temperature must not exceed 80°F/27°C db. Failure to follow these return-air limits may affect reliability of heat exchangers, motors and controls. (See Fig. 3.)

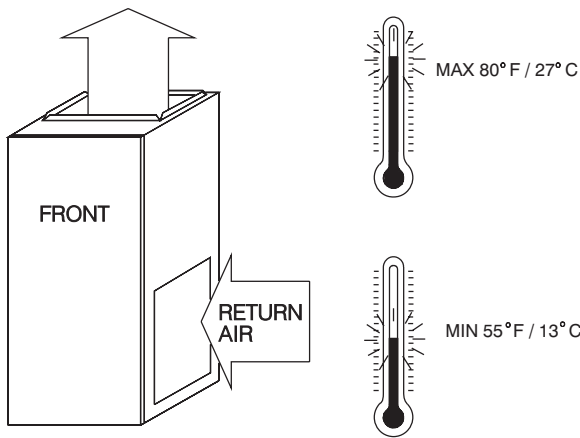

A06622

Fig. 3 - Return-Air Temperature

INTRODUCTION

The model 58CMR Furnaces are available in 2 sizes. Each size unit is capable of 3 heat/airflow combinations by a simple nozzle change. Unit 105-12 covers inputs of 70,000, 91,000, and 105,000 BTU, and unit 120-20 covers inputs of 119,000, 140,000, and 154,000 BTUH.

This furnace is a multipoise unit. It may be installed in the upflow, downflow, or horizontal configuration.

The furnace is shipped in the upflow configuration, complete with burner and controls. It requires a line voltage (115 vac) connection to control box, a thermostat hook-up as shown on wiring diagram, oil line connection(s), adequate duct work, and connection to a properly sized vent.

The air handling capacity of this furnace is designed for cooling airflow. Refer to Table 8 for expected airflows at various external duct static pressures.

LOCATION

Step 1 — General

This furnace is approved for reduced clearances to combustible construction, therefore, it may be installed in a closet or similar enclosure. Since this unit may be installed in an upflow, counterflow, or horizontal position, it may be located in a basement or on the same level as area to be heated. In any case, unit should always be installed level.

⚠ WARNING

ELECTRICAL SHOCK OR UNIT DAMAGE HAZARD

Failure to follow this warning could result in personal injury, death and/or property damage.

This furnace is not watertight and is not designed for outdoor installation. This furnace shall be installed in such a manner as to protect electrical components from water. Outdoor installation would lead to a hazardous electrical condition and to premature furnace damage.

⚠ WARNING

FIRE, EXPLOSION HAZARD

Failure to follow this warning could result in personal injury, death and/or property damage.

For attic installation, it is important to keep insulation 12 in. or more away from any furnace openings. Some types of insulating materials may be combustibles.

⚠ CAUTION

PERSONAL INJURY AND UNIT DAMAGE HAZARD

Failure to follow this caution may result in personal injury, equipment damage or improper operation.

This oil furnace may be used for construction heat provided that:

- The furnace is permanently installed with all electrical wiring, piping, venting and ducting installed according to these installation instructions. A return air duct is provided, sealed to the furnace casing, and terminated outside the space containing the furnace. This prevents a negative pressure condition as created by the circulating air blower, causing a flame roll-out and/or drawing combustion products into the structure.

- The furnace is controlled by a thermostat. It may not be “hot wired” to provide heat continuously to the structure without thermostatic control.

- Clean outside air is provided for combustion. This is to minimize the corrosive effects of adhesives, sealers and other construction materials. It also prevents the entrainment of drywall dust into combustion air, which can cause fouling and plugging of furnace components.

- The temperature of the return air to the furnace is maintained between 55°F (13°C) and 80°F (27°C) with no evening setback or shutdown. The use of the furnace while the structure is under construction is deemed to be intermittent operation per our installation instructions.

- The air temperature rise is within the rated rise range on the furnace rating plate, and the firing rate has been set to the nameplate value.

- The filters used to clean the circulating air during the construction process must be either changed or thoroughly cleaned prior to occupancy.

- The furnace, ductwork and filters are cleaned, as necessary, to remove drywall dust and construction debris from all HVAC system components after construction is completed.

- After construction is complete, verify furnace operating conditions including ignition, input rate, temperature rise, and venting, according to the manufacturer’s instructions.

In a basement, or when installed on floor (as in a crawlspace), it is recommended that unit be installed on a concrete pad that is 1 in. to 2 in. thick.

When installed in counterflow position, furnace must not be installed on combustible flooring, unless approved subbase is used. Also, since flue pipe is in a counterflow position, Downflow Conversion/Vent Guard Kit **MUST** be used.

When installed in a horizontal position, furnace may be suspended by using an angle iron frame, as long as total weight of both furnace and frame are allowed for in support calculations. (Other methods of suspending are acceptable.) When installed in the Horizontal Position, this furnace must not be installed on combustible flooring, unless the approved Horizontal Subbase is used.

The required minimum clearances for furnace are specified in Table 1.

The furnace should be located as close as possible to chimney or vent in order to keep vent connections short and direct. The furnace should also be located as near as possible to center of air distribution system.

58CMR

Table 1 – Minimum Clearances to Combustible Materials (in.)

UNIT APPLICATION		UPFLOW	DOWNFLOW	HORIZONTAL
Sides	Furnace	0	2	2
	Supply Plenum and Warm–Air Duct within 6 ft of furnace	1	2	1
Back	Service Clearance	0	1	4
Top	Furnace Casing or Plenum	2	2	2
	Horizontal Warm–Air Duct Within 6 ft of furnace	2	2	3
Flue Pipe	Horizontally or Below Pipe	4	4	4
	Vertically Above Pipe	9	9	9
Front		8	8	8
Bottom*		0	0	0

* Floor may be combustible

NOTE: Adequate service clearance should be provided over and above these dimensions as required.

Step 2 — Location Relative to Cooling Equipment

When installing furnace with cooling equipment for year-round operation, the following recommendations must be followed for series or parallel airflow:

1. In series airflow applications, coil is mounted after furnace in an enclosure in supply-air stream. The furnace blower is used for both heating and cooling airflow.

CAUTION

UNIT DAMAGE HAZARD

Failure to follow this caution may reduce the life of this unit. The coil **MUST** be installed on air-discharge side of furnace. Under no circumstances should airflow be such that cooled, conditioned air can pass over furnace heat exchanger. This will cause condensation in heat exchanger and possible failure of heat exchanger. Heat exchanger failure due to improper installation may not be covered by warranty.

2. In parallel airflow applications, dampers must be provided to direct air over furnace heat exchanger when heat is desired and over cooling coil when cooling is desired.

IMPORTANT: The dampers should be adequate to prevent cooled air from entering furnace. If manually operated, dampers must be equipped with a means to prevent operation of either cooling unit or furnace unless damper is in full cool or heat position.

INSTALLATION

Step 1 — Air for Combustion and Ventilation

WARNING

CARBON MONOXIDE, UNIT RELIABILITY HAZARD

Failure to follow this warning could result in personal injury, death and/or property damage.

Installation of this furnace in an area where it will receive contaminated combustion air must be avoided. Such contamination would include the following: ammonia, chlorine, hydrogen sulfide, halogenated hydrocarbons, carbon tetrachloride, cleaning solvents, hydrochloric acid, water softening chemicals, and similar chemicals.

WARNING

CARBON MONOXIDE, FIRE HAZARD

Failure to follow this warning could result in personal injury, death and/or property damage.

Do not block combustion-air openings in the furnace. Any blockage could result in improper combustion.

Step 2 — General

This furnace should be installed in a location in which facilities for ventilation permit satisfactory combustion of oil, proper venting, and maintenance of ambient temperature at safe limits under normal conditions of use. The location should not interfere with proper circulation of air within the confined space. (See NFPA-31 or B139.)

In addition to air needed for combustion, process air shall be provided as required for: cooling of equipment or material, controlling dew point, heating, drying, oxidation or dilution, safety exhaust, and odor control.

In addition to air needed for combustion, air shall be supplied for ventilation, including all air required for comfort and proper working conditions for personnel.

The barometric draft regulator (included with furnace) shall be installed in same room or enclosure as furnace in such a manner as to prevent any difference in pressure between regulator and combustion-air supply.

Air requirements for operation of exhaust fans, kitchen ventilation systems, clothes dryers, and fireplaces shall be considered in determining the adequacy of a space to provide combustion-air requirements.

The lack of a proper amount of combustion air can lead to serious furnace operational problems. Some of these problems are:

1. Excessive oil burner after-drip and oil fumes.
2. Sooting.
3. Melted oil burner igniter/relay control.
4. Air band or air turbulator settings more open than normal.
5. Lockouts on start-up.

The requirements for combustion and ventilation air depend upon whether furnace is located in a CONFINED or UNCONFINED space.

Unconfined Space

An unconfined space must have at least 50 cu ft for each 1,000 BTUH of total input for all the appliances (such as furnaces, clothes dryers, water heaters, etc.) in the space.

In unconfined spaces in buildings of conventional frame, brick, or stone construction, infiltration MAY be adequate to provide air for combustion, ventilation, and dilution of flue gases. This determination must be made on an individual installation basis and must take into consideration the overall volume of unconfined space, the number of windows and ventilation openings, the number of doors to the outside, internal doors which can close off unconfined space, and overall tightness of building construction. Consideration must also be given to the amount of storage items (furniture, boxes, etc.) within the unconfined space which take away from the air volume. (Refer to Table 2.)

Table 2 – Minimum Floor Area For Unconfined Space

FURNACE INPUT BTUH	MINIMUM SQ FT WITH 7-1/2 FT CEILING
70,000	467
91,000	607
105,000	700
119,000	793
140,000	933
154,000	1026

Many new buildings and homes (and older ones that have been weatherized) MUST BE considered as being of tight construction, therefore infiltration will not be sufficient to supply necessary air for combustion and ventilation.

A building can be considered as being of tight construction when:

1. Walls and ceilings exposed to outside atmosphere have a continuous water vapor retarder with a rating of 1 perm or less with openings gasketed or sealed; and/or
2. Weatherstripping has been added on operable windows and doors, and/or caulking or sealants are applied to areas such as joints around windows and door frames; between sole plates and floors; between wall-ceiling joints; between wall panels; at penetrations for plumbing, electrical, and fuel lines; and at other openings.

If combustion and ventilation air must be supplied to an unconfined space from outside, an opening with a FREE AREA of not less than 1 sq in. per 5,000 BTUH of total input of all appliances within unconfined space (but not less than 100 sq in.) must be provided. This opening must be located such that it cannot be blocked at any time.

Confined Space

A confined space has a volume of less than 50 cu ft per 1,000 BTUH of the total input rating for all appliances installed in that space.

NOTE: In calculating free area, consideration shall be given to blocking effect of louvers, grilles, or screens protecting openings. Screens used shall not be smaller than 1/4-in. mesh and shall be readily accessible for cleaning. If free area through a louver or grille is known, it shall be used in calculating size and free area specified. If design and free area are not known, it may be assumed that wood louvers have 20% free area and metal louvers and grilles have 60% free area. Louvers shall be fixed in open position or interlocked with furnace so they open automatically at furnace start-up and remain open during furnace operation.

The size of the openings depends upon whether the air comes from outside of the structure or an unconfined space inside the structure.

All Air From Inside the Structure

For a confined space, where air is taken from an interior space, 2 permanent openings of equal area are required. One opening must be within 12 in. of ceiling and the other within 12 in. of floor.

All Air From Outside of Structure

If outside air is supplied to a confined space, then the 2 openings must be equal and located as above.

1. If combustion air is taken through a permanent opening directly communicating with the outdoors, the opening shall have a minimum free area of 1 sq in. per 4,000 BTUH of total input rating for all equipment in the enclosure.
2. If combustion air is taken from outdoors through vertical ducts, the openings and ducts MUST have at least 1 sq in. of free area per 4,000 BTUH of the total input for all equipment within the confined space. (See Fig. 4 and 5.)

3. If combustion air is taken from outdoors through horizontal ducts, the openings and ducts MUST have at least 1 sq in. of free area per 2,000 BTUH of the total input for all equipment within the confined space. (See Fig. 6.)

When ducts are used to supply air, they must be of the same cross sectional area as free area of openings to which they connect. (See Fig. 7.)

The minimum dimension of rectangular air ducts must not be less than 3 in.

Step 3 — Ductwork Recommendations

⚠ WARNING

CARBON MONOXIDE POISONING HAZARD

Failure to follow this warning could result in personal injury or death.

When supply ducts carry air circulated by furnace to areas outside spaces containing furnace, return air MUST also be handled by a duct sealed to furnace casing and terminating outside space containing furnace.

58CMR

⚠ CAUTION

UNIT MAY NOT OPERATE

Failure to follow this caution may result in intermittent unit operation.

Return-air grilles and warm air registers MUST NOT be obstructed.

The proper sizing of warm air ducts is necessary to ensure satisfactory furnace operation. Ductwork should be in accordance with the latest editions of NFPA-90A (Installation of Air Conditioning and Ventilating Systems) and NFPA-90B (Warm Air Heating and Air Conditioning Systems) or Canadian equivalent.

The supply ductwork should be attached to flanged front opening provided at discharge end of furnace. The return-air ductwork should be attached to flanged rear opening of furnace. See Fig. 2 for dimensions of these openings.

NOTE: The blower access opening should not be used for return air.

The following recommendations should be followed when installing ductwork:

1. Install locking-type dampers in all branches of individual ducts to balance out system. Dampers should be adjusted to impose proper static at outlet of furnace.
2. A flexible duct connector of non-combustible material should be installed at unit on both supply- and return-air systems. In applications where extremely quiet operation is necessary, the first 10 ft (if possible) of supply and return ducts should be internally lined with acoustical material.
3. In cases where return-air grille is located close to fan inlet, there should be at least one 90° air turn between fan inlet and grille. Further reduction in sound level can be accomplished by installing acoustical air-turning vanes or lining duct as described in item 2 above.
4. When a single air grille is used, duct between grille and furnace must be the same size as return opening in furnace.

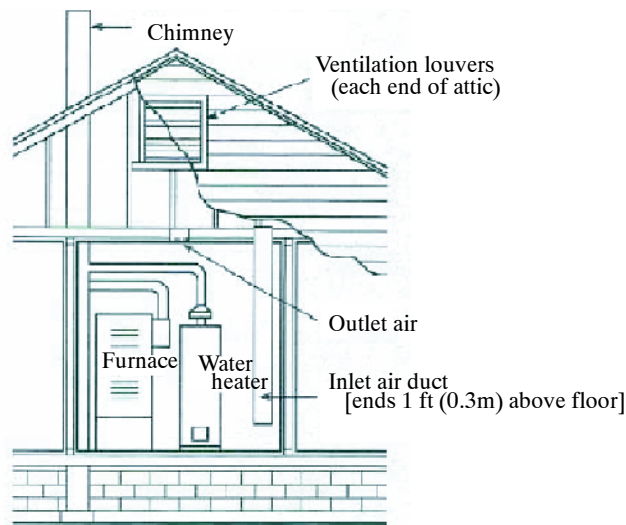

The Outlet air duct and Inlet air duct must have free area of not less than 1 square inch per 4000 BTUH based on the total input rating of all appliances in the space. The total free area or the ventilation louvers must have a free area of not less than 1 square inch per 5000 BTUH based on the total input rating of all appliances in the space.

Fig. 4 - Combustion Air Taken From Outdoors Through Vertical Ducts (without louvers in foundation)

A06463

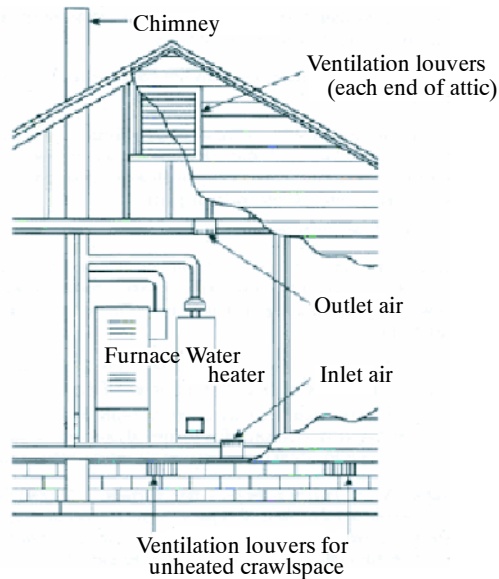

The Outlet air duct and Inlet air duct must have a free area of not less than 1 square inch per 4000 BTUH based on the total input rating of all appliances in the space. The total free area or the ventilation louvers must have a free area of not less than 1 square inch per 5000 BTUH based on the total input rating of all appliances in the space.

Fig. 5 - Combustion Air Taken From Outdoors Through Vertical Ducts (with crawspace louvers)

A06464

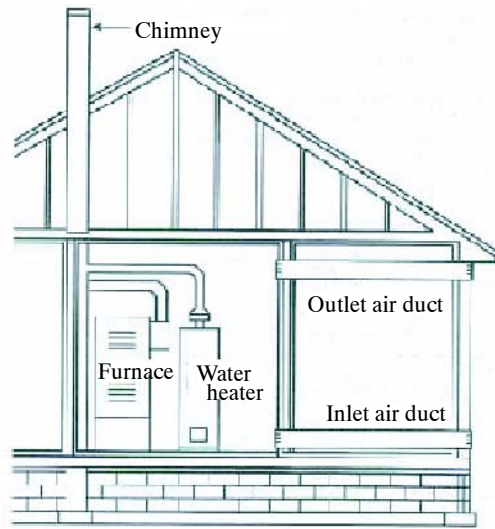

The Outlet air duct and Inlet air duct must have a free area of not less than 1 square inch per 2000 BTUH based on the total input rating of all appliances in the space.

A06465

Fig. 6 - Combustion Air Taken From Outdoors Through Horizontal Ducts

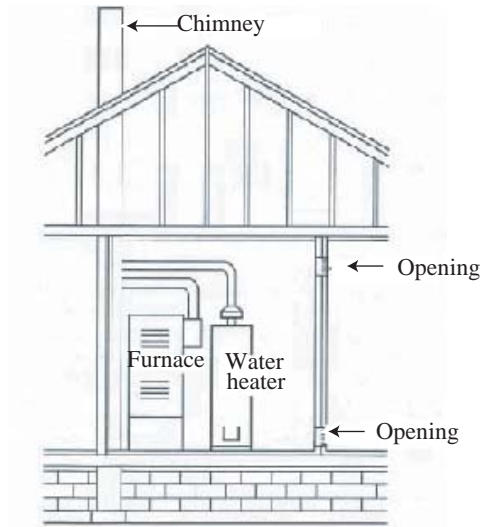

The top opening and the bottom opening must each be 8-in x 18-in when a 105 size furnace is installed. The top opening and the bottom opening must each be 10-in x 20-in when a 120 size furnace is installed.

A06466

Fig. 7 - Free Area Openings

Step 4 — Venting

Venting of furnace should be to the outside and in accordance with local codes or requirements of local utility.

OIL-FIRED APPLIANCES SHALL BE CONNECTED TO FLUES HAVING SUFFICIENT DRAFT AT ALL TIMES TO ENSURE SAFE AND PROPER OPERATION OF APPLIANCE.

For additional venting information, refer to ANSI/NFPA 211 Chimney, Fireplaces, Vents, and Solid Fuel Burning Appliances and/or CSA B139 Installation Code.

This furnace is certified for use with Type “L” vent (maximum flue gas temperature 575°F/302°C).

Vent System Inspection

Before furnace is installed, it is highly recommended that any existing vent system be completely inspected.

⚠ WARNING

CARBON MONOXIDE POISONING HAZARD

Failure to follow this warning could result in personal injury or death.

The following steps shall be followed for each appliance connected to the venting system being placed into operation, while all other appliances connected to the venting system are not in operation:

1. Seal any unused openings in venting system.
2. Inspect the venting system for proper size and horizontal pitch, as required in the NFPA31, Installation of Oil Burning Equipment and the Canadian Standard B140.4 Oil Fired Warm Air Furnaces. Determine that there is no blockage or restriction, leakage, corrosion and other deficiencies which could cause an unsafe condition.
3. As far as practical, close all building doors and windows and all doors between the space in which the appliance(s) connected to the venting system are located and other spaces of the building.
4. Close fireplace dampers.
5. Turn on clothes dryers and any appliance not connected to the venting system. Turn on any exhaust fans, such as range hoods and bathroom exhausts, so they are operating at maximum speed. Do not operate a summer exhaust fan.
6. Follow the lighting instructions. Place the appliance being inspected into operation. Adjust the thermostat so appliance is operating continuously.
7. Test for spillage from draft-hood equipped appliances at the draft-hood relief opening after 5 minutes of main burner operation. Use the flame of a match or candle.
8. If improper venting is observed during any of the above tests, the venting system must be corrected in accordance with the NFPA31, Installation of Oil Burning Equipment and the Canadian Standard B140.4 Oil Fired Warm Air Furnaces.
9. After it has been determined that each appliance connected to the venting system properly vents when tested as outlined above, return doors, windows, exhaust fans, fireplace dampers, and any other gas-fired burning appliance to their previous conditions of use.

For any chimney or vent, this should include the following:

1. Inspection for any deterioration in chimney or vent. If deterioration is discovered, chimney must be repaired or vent must be replaced.

2. Inspection to ascertain that vent system is clear and free of obstructions. Any blockage must be cleared before installing furnace.
3. Cleaning chimney or vent if previously used for venting a solid fuel burning appliance or fireplace.
4. Confirming that all unused chimney or vent connections are properly sealed.
5. Verification that chimney is properly lined and sized per the applicable codes. (Refer to list of codes in Safety Considerations section.)

Masonry Chimneys

This furnace can be vented into an existing masonry chimney. This furnace must not be vented into a chimney servicing a solid fuel burning appliance. Before venting furnace into a chimney, the chimney MUST be checked for deterioration and repaired, if necessary. The chimney must be properly lined and sized per local or national codes.

If furnace is vented into a common chimney, the chimney must be of sufficient area to accommodate the total flue products of all appliances vented into chimney.

The following requirements are provided for a safe venting system:

1. Be sure that chimney flue is clear of any dirt or debris.
2. Be sure that chimney is not servicing an open fireplace.
3. Never reduce pipe size below the outlet size of furnace. (See Fig. 2.)
4. All pipe should be supported using proper clamps and/or straps. These supports should be at least every 4 ft.
5. All horizontal runs of pipe should have at least 1/4 in. per ft of upward slope.
6. All runs of pipe should be as short as possible with as few turns as possible.
7. Seams should be tightly joined and checked for leaks.
8. The flue pipe must not extend into chimney but be flush with inside wall.
9. The chimney must extend 3 ft above highest point where it passes through the roof of a building and at least 2 ft higher than any portion of a building within a horizontal distance of 10 ft. It shall also be extended at least 5 ft above highest connected equipment flue collar.
10. Check local codes for any variance.

Step 5 — Factory-Built Chimneys

Listed factory-built chimneys may be used. Refer to chimney manufacturer’s instructions for proper installation.

Step 6 — Oil Burner

This furnace is supplied with a high-pressure atomizing retention head-type burner (for use with grade 1 or 2 Fuel Oil). The Riello oil burner operates with a pre-purge period of 10 sec and a safety timing of 5 sec. The burner flange is factory installed for an insertion length of 3-3/4-in. The oil pump is set to operate on a single line system. To operate on a two-line system the by-pass plug must be installed.

Step 7 — Oil Connections

Complete instructions for installing fuel oil piping can be found in oil burner Installation Instructions included with furnace.

Oil line entry holes are provided in side panels. Two holes are provided in each location so that a 2-pipe system may be used, if desired.

An oil filter should be used with all oil burners and should be installed as close to burner as possible.

⚠ CAUTION

UNIT COMPONENT HAZARD

Failure to follow this caution may result in unit component damage.

This burner is shipped with the oil pump set to operate on a **single** line system. To operate on a **two-line** system the by-pass plug must be installed. Do not operate a **single** line system with the by-pass plug installed. Operating a **single** line system with the by-pass plug installed will result in damage to the pump shaft seal. Pump pressure must be set at time of burner start-up. A pressure gauge is attached to the **PRESSURE PORT** for pressure readings. Two **PIPE CONNECTORS** are supplied with the burner for connection lines to burner pipe connectors. All pump port threads are **British Parallel Thread** design. Direct connection of NPT threads to the pump **will damage** the pump body. Riello manometers and vacuum gauges **do not** require any adapters, and can be safely connected to the pump ports. An NPT (metric) adapter (Part No. N05F017) must be used when connecting other gauge models.

Step 8 — Barometric Draft Control

The barometric draft control shipped with furnace **MUST** be used with furnace to ensure proper operation. Instructions for installing control are packed with control.

Step 9 — Blocked Vent Shut-Off (BVSO) For Chimney Venting

All oil furnaces installed in Canada must have a Blocked Vent Shut-Off.

Refer to Fig. 8-13 and the installation instructions supplied with the Blocked Vent Shut-Off for installation and wiring procedures.

The Blocked Vent Shut-Off must be installed in the flue between 2 in and 12 in from the furnace outlet and between the furnace outlet and draft regulator. (See Fig. 9.)

⚠ WARNING

FIRE, CARBON MONOXIDE POISONING HAZARD

Failure to follow this warning could result in personal injury, death and/or property damage.

DO NOT reset the device or restart the furnace unless the cause of the interruption has been identified and corrected by a qualified agency. Ensure that the Blocked Vent Shut-Off has been cleaned by a qualified agency before placing into service. Annual inspection and cleaning of the Blocked Vent Shut-Off by a qualified agency is required.

⚠ WARNING

FIRE, CARBON MONOXIDE POISONING HAZARD

Failure to follow this warning could result in personal injury, death and/or property damage.

The Blocked Vent Shut-Off **MUST** be inspected and maintained annually by a qualified agency.

⚠ WARNING

ELECTRICAL SHOCK HAZARD

Failure to follow this warning could result in personal injury or death.

Disconnect electrical power supply to the furnace before wiring the Blocked Vent Shut-Off.

⚠ CAUTION

CUT HAZARD

Failure to follow this caution may result in personal injury.

Sheet metal parts may have sharp edges or burrs. Use care and wear appropriate protective clothing, safety glasses, and gloves when handling parts and servicing furnaces.

⚠ WARNING

FIRE, CARBON MONOXIDE POISONING HAZARD

Failure to follow this warning could result in personal injury, death and/or property damage.

Do not dent or scratch the surface of the thermal switch. The thermal switch **MUST** be replaced if it is damaged.

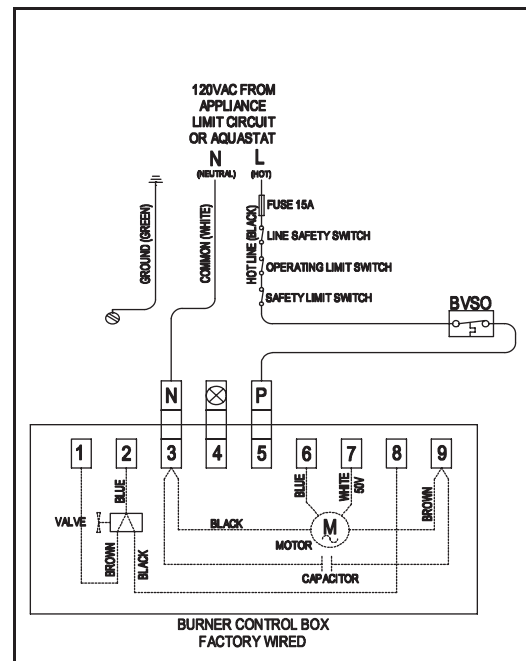
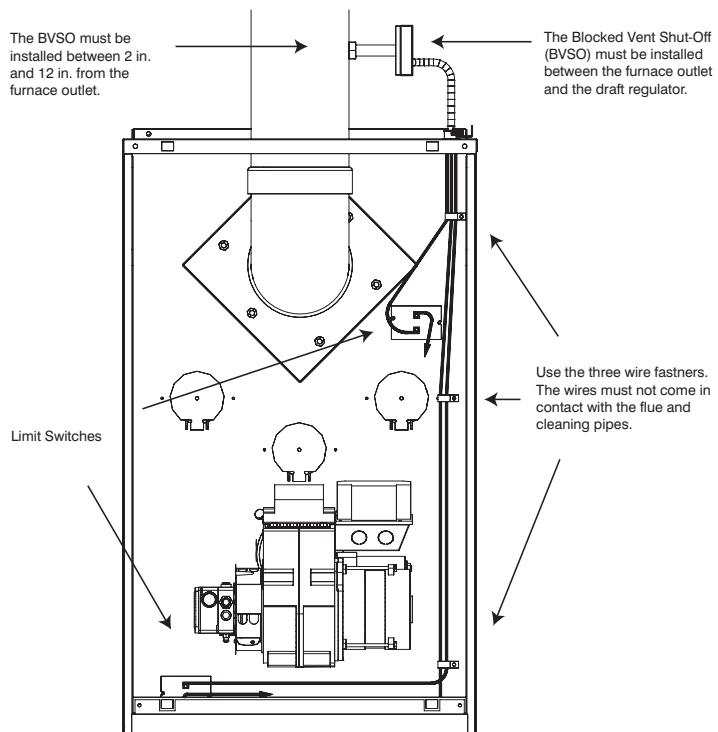

Diagram B
Riello

Fig. 8 - Wiring Diagram for Riello Burner

A06403



**Fig. 9 - Blocked Vent Shut-Off Device Wiring
(Installation shown: Upflow with vertical exhaust)**

A06614

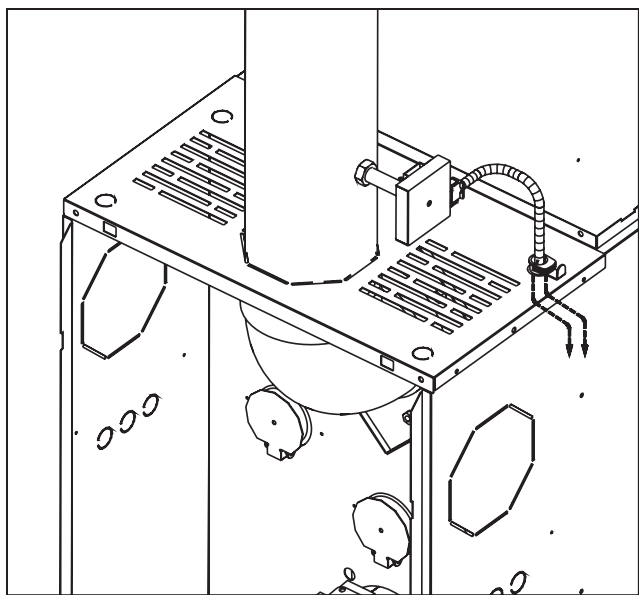

A06615

**Fig. 10 - Blocked Vent Shut-Off Device Wiring
(Installation: Upflow with vertical exhaust)**

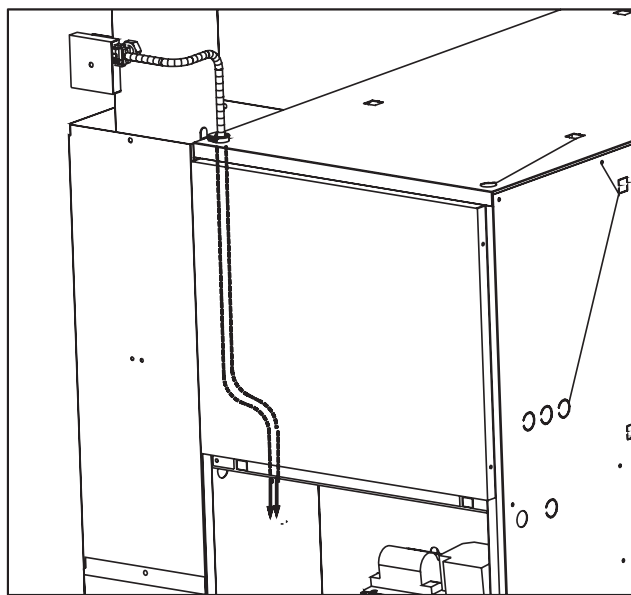

A06616

**Fig. 11 - Blocked Vent Shut-Off Device Wiring
(Installation: Downflow)**

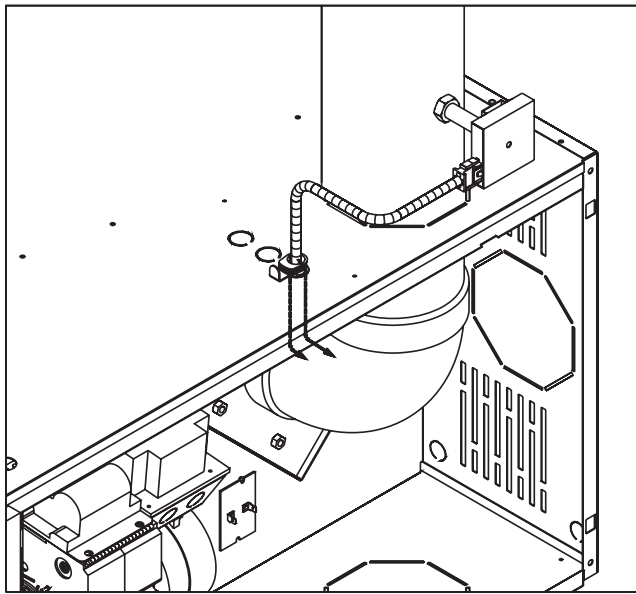

A06617

**Fig. 12 - Blocked Vent Shut-Off Device Wiring
(Installation: Horizontal with vertical exhaust)**

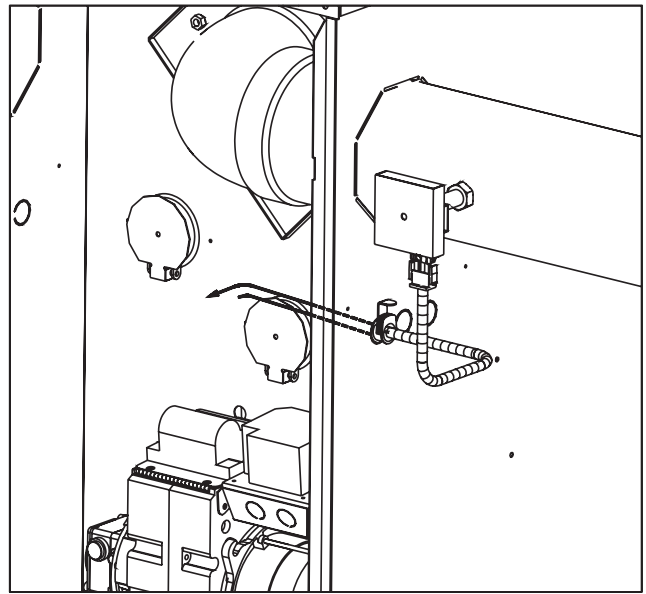

A06618

**Fig. 13 - Blocked Vent Shut-Off Device Wiring
(Installation: Horizontal with horizontal exhaust)**

58CMR

Step 10 — Electrical Connections

⚠ WARNING

ELECTRICAL SHOCK HAZARD

Failure to follow this warning could result in personal injury or death.

The unit cabinet must have an uninterrupted or unbroken electrical ground. A green ground screw is provided in control box for this connection.

⚠ WARNING

FIRE HAZARD

Failure to follow this warning could result in personal injury, death, or property damage.

Do not connect aluminum wire between disconnect switch and furnace. Use only copper wire.

115-V Wiring

Before proceeding with electrical connections, make certain that voltage, frequency, and phase correspond to that specified on unit rating plate. Also, check to be sure that service provided by utility is sufficient to handle load imposed by this equipment. Refer to rating plate or Table 3 for equipment electrical specifications.

Make all electrical connections in accordance with National Electrical Code (NEC) ANSI/NFPA 70-2005 and any local codes or ordinances that might apply. For Canadian installations, all electrical connections must be made in accordance with Canadian Electrical Code CSA C22.1 or sub-authorities having jurisdiction.

The control system depends on correct polarity of power supply. Connect HOT wire (H) and NEUTRAL wire (N) as shown in Fig. 14.

A separate line voltage supply **MUST** be used with a fused disconnect switch or circuit breaker between main power panel and unit. (See Fig. 14.)

Metallic conduit (where required/used) may terminate at side panel of unit. It is not necessary to extend conduit inside unit from side panel to control box.

When replacing any original furnace wiring, use only 105°C No. 14 AWG copper wire.

24-V Wiring

Instructions for wiring thermostat (field supplied) are packed in thermostat box. Make thermostat connections as shown in Fig. 14 at 24-v terminal board on electronic control board. Thermostat wire connections at R and W are the minimum required for oil heating operation.

Table 3 – Electric Data

UNIT SIZE	VOLTS PHASE HERTZ	OPERATING VOLTAGE RANGE		MAX UNIT AMPS	MIN. WIRE GAUGE	MAX WIRE LENGTH (FT.)†	MAX FUSE OR CKT BKR AMPS‡
		Max.*	Min.*				
105-12	115-1-60	132	104	12.2	14	26	15
120-20	115-1-60	132	104	15.7	12	26	20

* Permissible limits of voltage range at which unit will operate satisfactorily.

† Length shown is as measured 1 way along wire path between unit and service panel for maximum 2% voltage drop.

‡ Time-delay fuse is recommended.

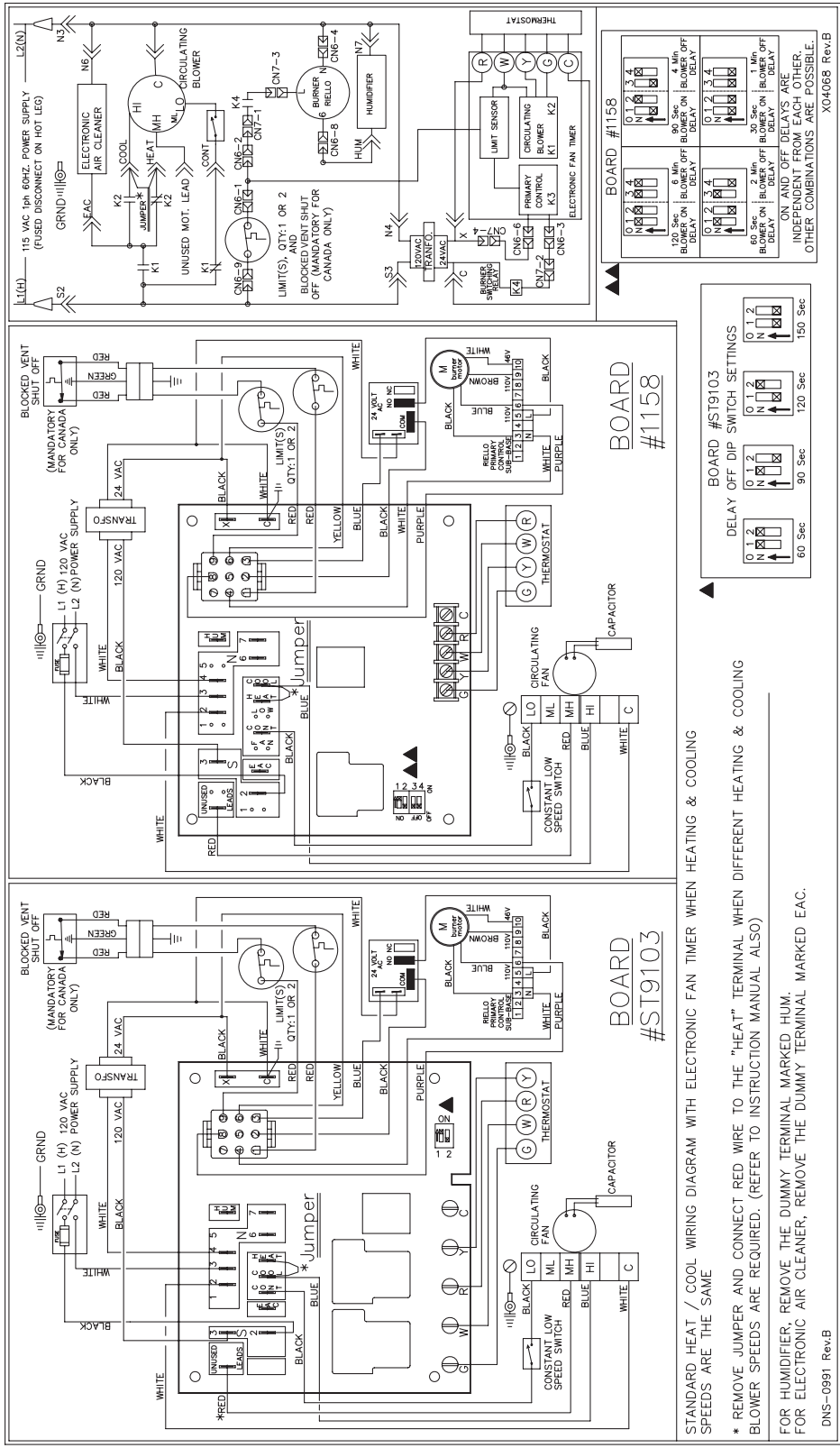

Fig. 14 - Wiring Diagram

A06620

Accessories

When installing optional accessories to this appliance, follow manufacturer's installation instructions included with accessory. Other than wiring for thermostat, wire with a minimum of type "T" insulation (63°F/17°C rise) must be used for accessories.

Filters

⚠ WARNING

FIRE, CARBON MONOXIDE POISONING HAZARD

Failure to follow this warning could result in personal injury, death and/or property damage.

Never operate unit without a filter or with filter access door removed.

An internal filter rack is provided as standard equipment with furnace and is located in blower compartment. A sufficient clearance should be provided for air filter access. Refer to Table 4 for filter rack flange dimensions for return air duct.

Table 4 – Filter Size (in.) and Quantity

UNIT SIZE	AIR FILTER SIZE	FLANGE OPENING SIZE
105–12	16 x 24 x 1 or 16 x 25 x 1	15 x 23
120–20	20 x 30 x 1	19 x 29

Step 11 — Horizontal or Downflow Installation

For horizontal installation, determine which "side" will become the "top", when the unit is laid down. Remove the flue pipe clearance knock-out from the top of that side panel. Install the flue elbow so that it exits the cabinet of the furnace through that opening.

For counterflow installation, the flue pipe must exit the cabinet through 1 of the side panel openings (as above), then extended up the side of the furnace. Insure that adequate clearances to combustibles are observed. Downflow Conversion/Vent Guard Kit MUST be used.

Remove burner by loosening mounting nuts and turn oil burner slightly counterclockwise to unlock the key hole burner flange. Prevent putting undue strain on burner wiring. (It may be necessary to disconnect burner wiring in some cases.)

To reinstall burner, insert on the four burner studs on key hole burner flange and turn it clockwise to lock it and tighten nuts.

IMPORTANT: Burner must always be installed in the upright position with ignition control on top.

START-UP, ADJUSTMENT, AND SAFETY CHECKOUT

Step 1 — Operational Checkout

Installation of furnace is now complete. Perform the following checkout procedures.

1. Correct nozzle size has been selected for desired input rate.
2. Electrical wiring is completed according to Fig. 14.
3. Blower wheel support is removed.
4. Blower access door is secured in place.
5. Valve on oil supply line is open.
6. RESET BUTTON on primary control is pushed down.
7. Flame observation door is closed.

8. Thermostat is set for heating mode and set above room temperature.

If all of the above items have been performed, set main electrical switch to ON position and burner should start. When burner starts, proceed to Combustion Check Section.

Step 2 — Combustion Check

In order to obtain optimum performance from oil burner, the following setup procedures must be followed:

1. A test kit to measure smoke, stack draft, over-fire draft, CO₂, oil-pump pressure, and stack temperatures MUST be used in order to obtain proper air band setting. Although all of the above measurements are required for optimum setup and efficiency data, the most important readings that must be taken are smoke number, over-fire draft, stack draft, and oil pump pressure.
2. The proper smoke number has been established by engineering tests to be between 0 and 1. This degree of smoke emission is commonly referred to as a "trace" of smoke. It is recommended to use a Bacharach true-spot smoke test set or equivalent.
3. In order to ensure proper draft through furnace, a barometric draft regulator (supplied with furnace) must be installed. In order for this device to function properly, barometric damper must be mounted with hinge pins horizontal and face of damper vertical. (See instructions included with damper.) The draft regulator should be adjusted after furnace has been firing for at least 5 min., and set between -0.025 and -0.035 in. wc. (See Table 5.)

Table 5 – Furnace Draft Conditions (in wc)

FURNACE INPUT (BTUH)	FLUE DRAFT MINIMUM	OVER-FIRE DRAFT MAXIMUM	TOTAL RESTRICTION THROUGH HEAT EXCHANGER
70,000	-0.025	0.010	0.020 to 0.035
91,000	-0.025	0.020	0.030 to 0.045
105,000	-0.025	0.025	0.035 to 0.050
119,000	-0.025	0.025	0.035 to 0.050
140,000	-0.025	0.025	0.035 to 0.050
154,000	-0.025	0.025	0.035 to 0.050

4. The over-fire draft, which is taken through observation door (located in center line above burner in front panel of furnace), is a measurement necessary to determine if there is a blockage between oil burner and flue outlet.

There should be a total pressure drop of between 0.020 and 0.05 in. wc. through furnace as shown in Table 5. The over-fire draft must be set within the range shown in Table 5.

A reading outside the range shown in Table 5 (for example +0.1 in. wc.) would indicate that furnace is in an extremely high-pressure condition in primary section. This condition may be caused by any of the following problems:

- a. Excessive combustion air due to air band being too wide open.
- b. A lack of flue draft (chimney effect) or some other blockage, such as soot, in secondary section of heat exchanger.
- c. Use of an oversized nozzle input.
- d. Pump pressure over the values listed in Table 6.

Table 6 – Burner Input and Nozzle Size

FURNACE INPUT (BTUH)	FIRING RATE GAL/HR (US)*	RIELLO OIL BURNER		PUMP PRESSURE (PSIG)
		NO. 40 SERIES MODEL	DELAVAN NOZZLE	
70,000	0.50	F3	0.40 - 70A	160
91,000	0.65	F3	0.50 - 70W	170
105,000	0.75	F3	0.65 - 70W	135
119,000	0.85	F5	0.75 - 70B	130
140,000	1.00	F5	0.85 - 70W	140
154,000	1.10	F5	1.00 - 70W	125

* For rating purposes only.

- The CO₂ and stack-temperature instruments enable you to obtain data required to determine thermal efficiency of furnace.
- An oil filter should be installed as close to burner as possible with ALL oil burners and is essential on lower firing rate burners. We recommend the use of a low-pressure-drop oil filter such as the General Filter, Inc. model #1A-25A or equivalent.
- The oil pressure regulator is factory set to give oil pressure of 135 psig for the model having 105,000 BTUH input and 130 psig for the model having 119,000 BTUH input. The firing rate noted on nameplate may be obtained using the nozzles and pump pressures indicated in Table 6. The proper oil burner turbulator setting for all the firing rates is 0 (zero).
- On a new installation, air entrapped in oil line leading from tank to nozzle must be thoroughly purged in order to prevent excessive after drip. The oil pump is provided with a special fitting which allows purging of any air between tank and oil pump. The proper procedure for performing this operation is as follows:
 - Place a piece of clear plastic 1/4-in. diameter tubing over purge fitting on oil pump.
 - Start oil burner, then open purge fitting and allow burner to run until purge tube is completely free of air bubbles.
 - Tighten purge fitting. Allow oil to run to nozzle and fire burner.
 - If purging takes longer than 15 sec and no flame has been established, burner stops. Push reset button on front of primary control to restart burner.
 - For detailed information on operation of primary control, refer to instructions included with furnace.

After all the setup procedures mentioned above have been completed, the burner should be allowed to operate and an inspection mirror should be used to observe the flame pattern at tip of nozzle. Any irregularities, such as burning to one side or pulsating flame patterns, should be corrected by changing nozzle.

Step 3 — Fan Adjustment Check

⚠ WARNING

FIRE HAZARD AND UNIT RELIABILITY

Failure to follow this warning could result in personal injury, death and/or property damage.

When operating furnace in heating mode, static pressure and temperature rise (supply-air temperature minus return-air temperature) must be within those limits specified on rating label.

This furnace is equipped with a 4-speed direct-drive motor to deliver a temperature rise within range specified on rating plate,

between return and supply plenums, at external duct static pressure noted on rating plate.

Adjust fan speed ACCORDING TO OIL INPUT SELECTED so that temperature rise is within rise range specified on rating plate. (See Table 7.) Consult wiring diagram for speed changes on direct-drive motor.

Table 7 – Speed Selection

UNIT SIZE	FURNACE INPUT (BTUH)	RECOMMENDED BLOWER SPEED
105 – 12 120 – 20	70,000/119,000	Med – Low
	91,000/140,000	Med – High
	105,000/154,000	High

To adjust fan off time, set dip switches on control board to obtain desired timing. (See Fig. 15.)

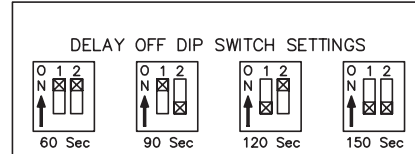

Honeywell Control Board

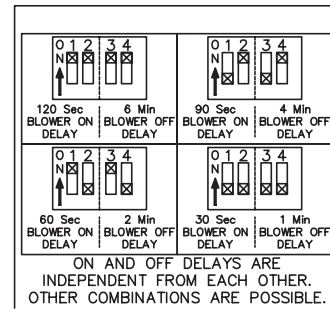

UTEC Control Board

A06462

Fig. 15 - Fan Off Time Dip Switch Settings (Black Box Represents Switch Position)

Step 4 — Limit-Control Check

After furnace has been in operation for at least 15 minutes, restrict return-air supply by blocking filters or closing return registers and allow furnace to shut down on high limit. The burner should shut off and main blower should continue to run.

Remove restriction and burner should come back on in a few minutes.

Step 5 — For Year-Round Air Conditioning

This furnace is designed for use in conjunction with cooling equipment to provide year-round air conditioning. The blower has been sized for both heating and cooling, however, fan-motor speed may need to be changed to obtain necessary cooling airflow.

Step 6 — Heating

The blower speed is factory set to deliver required airflow at normal duct static pressure.

Step 7 — Cooling

The blower speed may be field adjusted to deliver required airflow for cooling application. (See Table 8.)

Step 8 — Constant Blower Switch

This furnace is equipped with a constant low-speed blower option. Whenever room thermostat is not calling for heating or cooling, blower runs on low speed in order to provide air circulation. If constant blower option is not desired, the rocker switch on top of cabinet may be used to turn off constant speed.

Table 8 – Airflow Data

UNIT-SIZE	BLOWER SPEED	EXTERNAL STATIC PRESSURE (in wc)							
		0.2	0.3	0.4	0.5	0.6	0.7	0.8	0.9
105 – 12	High	1425	1350	1305	1250	1170	1030	925	805
	Med-High	1130	1045	1000	950	885	820	745	670
	Med-Low	840	810	770	740	685	635	580	500
	Low	725	730	740	745	730	715	690	665
120 – 20	High	2080	2041	1965	1864	1702	1576	1474	1336
	Med-High	1892	1859	1770	1675	1550	1449	1330	1217
	Med-Low	1556	1475	1394	1318	1211	1134	1051	938
	Low	1221	1164	1081	998	926	855	782	653

NOTES:

1. Airflow values in cubic ft per minute (CFM) rounded to nearest 5 CFM.
2. Data taken with filters in place.

CARE AND MAINTENANCE

⚠ WARNING

ELECTRICAL SHOCK, FIRE, EXPLOSION HAZARD

Failure to follow this warning could result in personal injury, death and/or property damage.

The ability to properly perform maintenance on this equipment requires certain expertise, mechanical skills, tools, and equipment. If you do not possess these, do not attempt to perform any maintenance on this equipment other than those procedures recommended in the User's Manual.

⚠ WARNING

ELECTRICAL SHOCK HAZARD

Failure to follow this warning could result in personal injury or death.

Before performing any service functions, unless operations specifically require power to be on, make sure all utilities are turned off upstream of appliance.

Step 1 — General

In order to keep this furnace in good operating condition and to maintain its warranty, the furnace **MUST** be serviced on an annual basis. This servicing includes a nozzle change, a burner inspection, a visual check of tube passages through flue outlet and clean-out ports, and a visual inspection of combustion chamber when burner is removed.

⚠ WARNING

CARBON MONOXIDE POISONING HAZARD

Failure to follow this warning could result in personal injury or death.

Failure to replace any heat exchanger gaskets with new gaskets when any heat exchanger plates or covers are removed could lead to heat exchanger leakage or sooting.

Depending on above inspection, service could also include a cleaning and vacuuming of heat exchanger tubes and possibly the heat exchanger drum section.

Removal of any heat exchanger components which are sealed by gaskets requires replacement of gasket.

This furnace should never be operated without an air filter. Disposable filters should be replaced at least once a year. If

equipped to provide cooling, filters should be replaced a minimum of twice a year. Permanent filters should be cleaned at least twice a year.

NOTE: ALWAYS KEEP MAIN OIL VALVE TURNED OFF IF BURNER IS SHUT DOWN FOR AN EXTENDED PERIOD OF TIME.

Step 2 — Oil Burner

For optimum performance, oil-burner nozzle should be replaced once a year. Contact your service technician if you are unsure of this procedure.

The procedure for nozzle installation and/or replacement is outlined in oil burner instruction manual which came with furnace. After replacement of nozzle, burner should be adjusted in accordance with Combustion Check section of this instruction.

Step 3 — Heat Exchanger and Flue Pipe

Ordinarily, it is not necessary to clean heat exchanger or flue pipe every year, but it is necessary to have your service technician check unit before each heating season to determine whether cleaning or replacement of parts is required.

If cleaning is necessary, the following steps should be performed:

⚠ CAUTION

BURN HAZARD

Failure to follow this caution may result in personal injury.

If furnace has been in operation, some surfaces may be hot. Allow time for unit to cool down.

1. Turn off all oil and electrical supplies upstream of furnace.
2. Disconnect flue pipe.
3. Remove flue collar panel located in front part of furnace.
4. Remove baffle from secondary heat exchanger.
5. Disconnect oil line and remove oil burner from furnace.
6. Open 2 cleanout doors located in upper part of front panel of furnace.
7. Clean primary and secondary heat exchanger with stiff brush and vacuum cleaner.
8. Before re-assembly, the heat exchanger and combustion chamber should be inspected to determine if replacement is required.
9. After cleaning, replace baffle, flue collar plate, oil burner, and close the 2 cleanout access doors. Reconnect flue pipe and oil line.
10. Re-adjust burner for proper operation.

58CMR

Step 4 — Blocked Vent Shut-Off (BVS) Cleaning



WARNING

FIRE, CARBON MONOXIDE POISONING HAZARD

Failure to follow this warning could result in personal injury, death and/or property damage.

Do not dent or scratch the surface of the thermal switch. The thermal switch **MUST** be replaced if it is damaged.



WARNING

ELECTRICAL SHOCK HAZARD

Failure to follow this warning could result in personal injury or death.

Disconnect electrical power supply to the furnace before wiring the Blocked Vent Shut-Off.



WARNING

FIRE, CARBON MONOXIDE POISONING HAZARD

Failure to follow this warning could result in personal injury, death and/or property damage.

The Blocked Vent Shut-Off **MUST** be inspected and maintained annually by a qualified agency.

1. Disconnect power to the furnace.
2. Remove 2 screws from BVS cover.
3. Remove cover.
4. Remove 2 screws holding BVS switch to assembly base.
5. Without disconnecting the wires, remove BVS switch.
6. Remove any build-up from BVS assembly or switch.
7. **Replace the BVS switch if there are any dents, scratches or other damage to the surface of the switch.**
8. Remove any build-up or obstructions from inside the heat transfer tube.
9. Re-mount the BVS switch using the two screws removed in item 4.
10. Re-attach BVS cover using the two screws removed in item 2.
11. Reset BVS switch.
12. Turn on power to furnace.

Step 5 — Blower Removal

To remove blower from furnace:

1. Turn off all oil and electrical supplies upstream of furnace.
2. Remove burner access and blower door.
3. Remove blower retaining screw (on blower shelf).
4. Remove cover from control box and disconnect thermostat and power wires from the board.
5. Slide blower forward on rails toward front of unit.
6. Reverse items 1 through 5 to re-install blower. Refer to wiring diagram (Fig. 14) of these instructions or diagram located on inside of blower door to properly rewire unit.