

INSTALLATION INSTRUCTIONS

T-59 SPACE TEMPERATURE SENSOR WITH OVERRIDE & SETPOINT ADJUSTMENT

The latest version of the T-59 sensor supports several new features, while remaining backwards compatible with all previous T-59 features.

SUMMARY OF NEW FEATURES

The T-59 supports the following new features:

- Actual display of adjusted heating and cooling setpoint
- Enhanced range of setpoint offset
- Optional Heat/Cool mode input toggle
- Optional Occ/Unocc mode input toggle

INSTALLATION AND PROGRAMMING PROCEDURES

COMPONENT LIST

The Model T-59 Space Temperature Sensor with Override & Setpoint Adjustment consists of the following components:

- (1) Space temperature sensor
- (2) 6-32" x 1" round head machine screws

LOCATING THE SENSOR

The T-59 space temperature sensor measures building interior temperature and should be located on an interior building wall. The sensor wall plate accommodates the NEMA standard 2 x 4 junction box. The sensor can be mounted directly on the wall surface if acceptable by local codes.

Do not mount the sensor in drafty locations such as near air conditioning or heating ducts, over heat sources such as baseboard heaters, radiators, or directly above wall mounted lighting dimmers. Do not mount the sensor near a window that may be opened, or near a wall corner or door. Sensors mounted in these areas will have inaccurate and erratic sensor readings.

Mount the sensor approximately 5 ft from the floor, in an area representing the average temperature in the space. Allow at least 4 ft between the sensor and any corner and mount the sensor at least 2 ft from an open doorway. Refer to the drawing on Page 2.

Note: Clean sensor with damp cloth only. Do not use solvents.



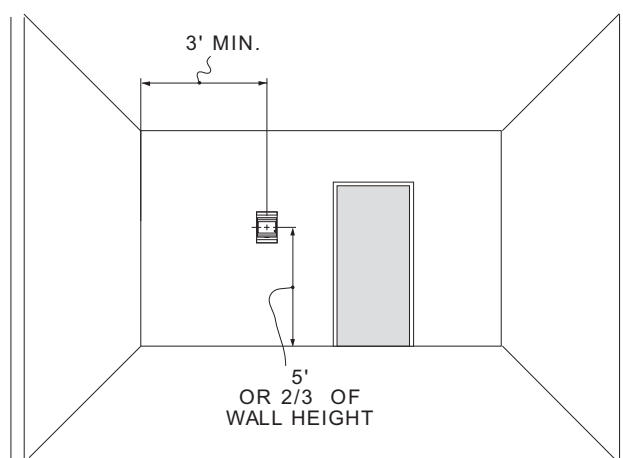

TO INSTALL THE T-59 SENSOR

1. Locate the two Allen-type screws at the bottom of the sensor.
2. Turn the two screws clockwise to release the cover from the sensor wall mounting plate.
3. Lift the cover from the bottom and then release it from the top fasteners.
4. Feed the wires from the electrical box through the opening in the center of the sensor mounting.
5. Using 2 no. 6-32 x 1 mounting screws (provided with the sensor) secure the sensor to the electrical box.
6. Use 16-20 gage wires for all sensor installations. For additional wiring instructions, see Wiring The T-59 Sensor, which appears later in these installation instructions.
7. Replace the cover by inserting the cover at the top of the mounting plate first, then swing the cover down over the lower portion. Rotate the two Allen head screws counterclockwise until the cover is secured to the mounting plate and located in position.

Figure 1
T-59 Space Temperature Sensor

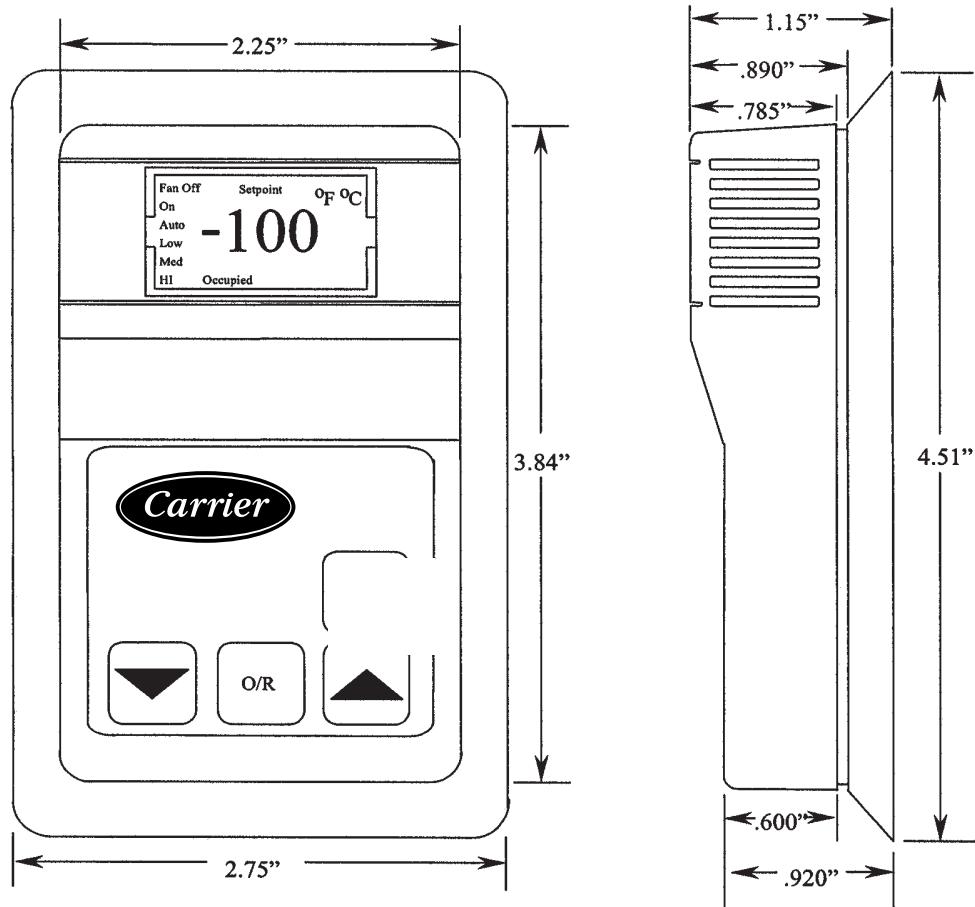

WIRING THE T-59 SENSOR

1. Identify the sensor wiring cable. Refer to Figure 2 below.
2. Strip back the cable jacket for at least 3 inches. Strip 1/4 in of insulation from each conductor. Cut the shield and drain wire from the sensor end of the cable.
3. See Figure 2 for wire connections. Use a three-conductor shielded cable for the sensor and setpoint adjustment connections. Be sure to connect the cable shield to the ground at controller only. Use a separate two-conductor cable for power wiring.

Note: Do not run the T-59 sensor wiring in any conductor with line powered wiring. The T-59 24 VAC power wire should be run in a separate cable from the sensor and setpoint adjustment cable by at least 6 inches along the entire wiring run. Carrier requires the use of a separate isolated transformer to power the T-59.

Figure 2
T-59 Space Temperature Sensor - Wiring

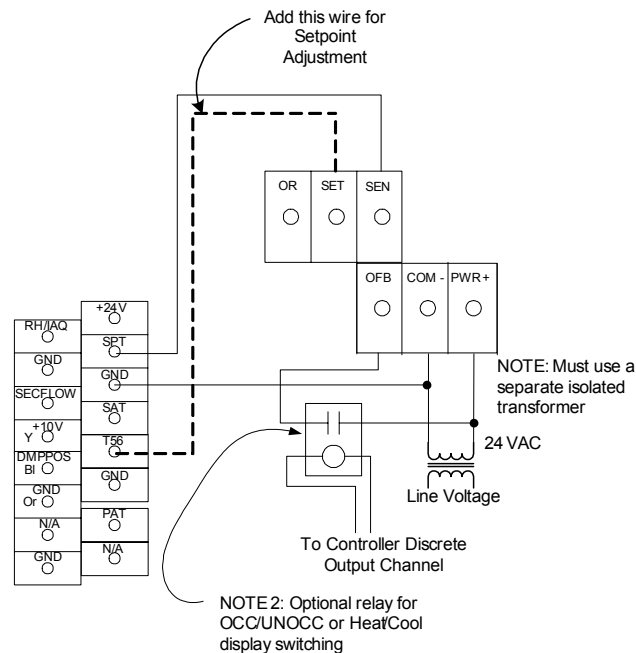

CCN SERVICE JACK WIRING

The T-59 includes a telco-style service jack to facilitate easy network access for Network Service Tool or ComfortVIEW computers. Unlike other CCN sensors, the T-59 does not provide screw type bus terminals; the telco jack is wired using simple pig-tail connections secured with wire nuts. The color code for the wires on the service jack is as follows:

- Black connects to CCN + (normally red)
- Red connects to CCN Ground (normally white)
- Yellow connects to CCN – (normally black)

MODIFYING THE T-59 SENSOR OPTIONS

Follow these instructions to access and modify any of the T-59's user options and field service options. User accessible options occupy pages 101 through 109 and field service options occupy pages 126 through 132. Refer to Table 1 and Table 2 for a list of all user accessible options along with option page numbers and valid option values.

Note: The T-59 is not a communicating device. As such, setpoint and offset values at the T-59 must be set to match those values as they are configured in the associated controller. Controller setpoint or offset values that are changed after commissioning must then be manually entered at the T-59 to ensure consistency between the T-59 and the controller.

1. While the sensor is displaying the current temperature, simultaneously press and hold down the DOWN and UP keys.

While both keys are pressed the T-59 display will initially continue to show the current temperature. After the two keys are held for approximately 30 seconds, however, the temperature display will change to display option page number *100*. This indicates successful entry into option page mode. Once the *100* is displayed, you can release the DOWN and UP keys.

Note: If the DOWN key is pressed while the *100* is displayed, the sensor will display the current firmware version.

To select the options pages 126 through 132, press the UP key until the display shows 1— (one dash dash). Then, press and hold the DOWN and UP keys at the same time. After approximately 2 seconds, the display will change to show *126*, indicating successful entry into the field service mode. Change an option page value as described previously.

To return to normal operation from the option page mode, press the UP key until the display shows 1- - (one dash dash). Press the DOWN key to return the T-59 sensor to normal operation.

Note: While in the option value mode, if there is no keyboard activity for approximately 10 seconds, the T-59 sensor will automatically return to the option page mode.

While in the option page mode, if there is no keyboard activity over a period of approximately 30 seconds, the T-59 sensor will automatically return to normal operation.

2. Refer to Table 1 and Table 2 for a description of the T-59's option pages and valid option values. To change the option page number, press the UP key until the desired option page is displayed.
3. Once the desired option page is displayed, press the DOWN key to enter option value mode.
4. Press the UP key to change the displayed option value. Pressing the UP key increments through the option value range of *00* to *12*, and then repeats the cycle. If you unintentionally go beyond the desired value, continue to press the UP key until the correct value is displayed.

Note: Be sure to select a valid option value. Refer to Table 1. While in option value mode, if a key is not pressed over a period of approximately 10 seconds, the T-59 sensor display will automatically return to option page mode.

5. When the desired value is displayed, press the DOWN key to store the selected value and return to option page mode.
6. To return the T-59 sensor to normal operation from option page mode, press the UP key until the display shows 1- -. Then press the DOWN key.

Table 1
User Accessible Options

Page	Description
100	Firmware Version
101	Temperature Scale 00 = °F 01 = °C
102	Temperature Offset (Sensor Trim) °F 00 = -5 01 = -4 02 = -3 03 = -2 04 = -1 05 = 0 (typical) 06 = 1 07 = 2 08 = 3 09 = 4 10 = 5
103	Setpoint Display Normal Setpoint Display 00 to 09 = Do Not Use Offset Setpoint Display 10 = -02 to 02°F (-02 to 02°C) 11 = -03 to 03°F (-03 to 03°C) 12 = -05 to 05°F (-05 to 05°C)
104	Keep Set at 00
105	Setpoint Lockout 00 = Disable Lockout 01 = Enable Lockout
106	Keep Set at 00
107	Keep Set at 00
108	Display Mode 00 = Normal 01 = Setpoint Only
109	Keep Set at 00



Table 2
Field Service Options

Page	Description
126	Setpoint mode 00 = Use option page 103 setting 01 = Display single offset set point 02 = Display Heat/Cool set points 03 = Display Heat/Cool set points w/ Occupied (Occupied icon is shown in setpoint display mode.)
127	Setpoint feedback 00 = Disable feedback 01 = Enable Occupied/unoccupied feedback 02 = Enable Heat/Cool feedback
128	Maximum offset adjustment for setpoint * Note: When using the -00° to +00° selection, option page 105 must be set to value 01. * 00 = -00° to +00° (F or C) 01 = -01° to +01° (F or C) 02 = -02° to +02° (F or C) (Default) 03 = -03° to +03° (F or C) 04 = -04° to +04° (F or C) 05 = -05° to +05° (F or C) 06 = -06° to +06° (F or C) 07 = -07° to +07° (F or C) 08 = -08° to +08° (F or C) 09 = -09° to +09° (F or C) 10 = -10° to +10° (F or C)
129	Occupied heat setpoint 60 = Default (Range is 10 to 89)
130	Occupied cool setpoint 65 = Default (Range is 10 to 89)
131	Unoccupied heat setpoint 55 = Default (Range is 00 to 99)
132	Unoccupied cool setpoint 90 = Default (Range is 00 to 99)

