

Horizontal & Vertical Packaged Products



GT-PX (50YD) Two-Stage Puron® Series
 GT-PG (50YE) Single-Stage Puron® Series
 GT-G (50YC) Packaged R22 Series

Residential Horizontal & Vertical
 Packaged Geothermal Heat Pumps

Installation, Operation &
 Maintenance Instructions
 97B0046N01
 Revision: 21 Aug, 2007D

Table of Contents

Model Nomenclature	2	Low Water Temperature Cutout Selection	31
Storage	3	Water Valve Wiring	32
Pre-Installation	3	Thermostat Wiring	33-34
Physical Data	4-5	ECM Blower Control	35-36
Unit Dimensions	6-14	Blower Data	37-39
Horizontal Unit Installation	15	Electrical Wiring Schematics	40-46
Field Conversion of Air Discharge	17	CXM Controls	47
Condensate Piping Installation	18	CXM Safety Control Reset	48-50
Duct System Installation	18	Unit Start-Up and Operating Conditions	51
Vertical Unit Installation	19	Unit and System Checkout Procedure	52
Water Connections	21	Unit Start-Up Procedure	52-53
Ground Loop Applications	21-22	Coax Pressure Drop Table	54
Open Loop - Ground Water Systems	23-24	Operating Pressures	55-59
Water Quality Standards	25	Preventive Maintenance	60
Hot Water Generator	26-27	Troubleshooting	61-62
Electrical - Line Voltage	28-29	Functional & Performance Troubleshooting	63-64
Power Wiring	29-30	Refrigerant Circuit Diagram	65
Electrical - Low Voltage Wiring	31	Warranty	67

MODEL NOMENCLATURE: GENERAL OVERVIEW FOR ALL H & V SERIES

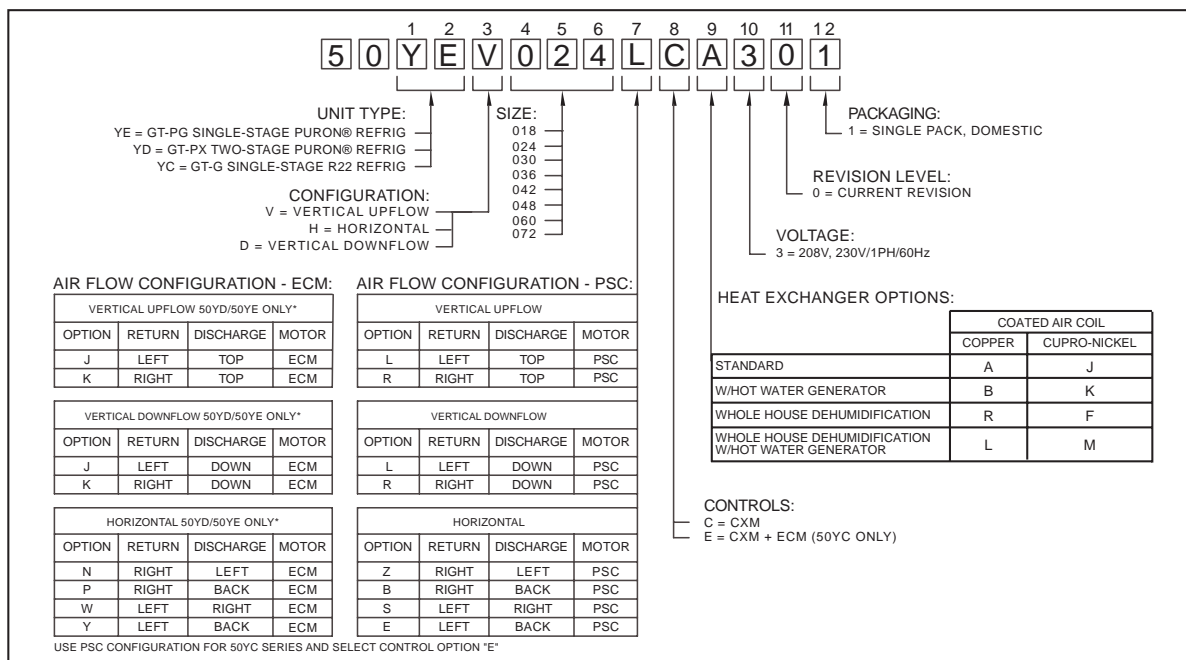

NOTE: Some options/configurations not available on all series. Please consult Specification Catalogs for model specific options.

Rev.: 08 Aug, 2007D

NOTE: Above model nomenclature is a general reference. Consult individual specification catalogs for detailed information.

Safety

Warnings, cautions and notices appear throughout this manual. Read these items carefully before attempting any installation, service or troubleshooting of the equipment.

DANGER: Indicates an immediate hazardous situation, which if not avoided will result in death or serious injury. DANGER labels on unit access panels must be observed.

WARNING: Indicates a potentially hazardous situation, which if not avoided could result in death or serious injury.

CAUTION: Indicates a potentially hazardous situation or an unsafe practice, which if not avoided could result in minor or moderate injury or product or property damage.

NOTICE: Notification of installation, operation or maintenance information, which is important, but which is not hazard-related.

⚠ WARNING! ⚠

WARNING! Verify refrigerant type before proceeding. Units are shipped with Puron® (R410A), R22 and R407c refrigerants. The unit label will indicate which refrigerant is provided. The Puron® Application Guideline and Service Manual should be read and understood before attempting to service refrigerant circuits with Puron® refrigerant.

⚠ WARNING! ⚠

WARNING! To avoid the release of refrigerant into the atmosphere, the refrigerant circuit of this unit must be serviced only by technicians who meet local, state, and federal proficiency requirements.

⚠ WARNING! ⚠

WARNING! All refrigerant discharged from this unit must be recovered WITHOUT EXCEPTION. Technicians must follow industry accepted guidelines and all local, state, and federal statutes for the recovery and disposal of refrigerants. If a compressor is removed from this unit, refrigerant circuit oil will remain in the compressor. To avoid leakage of compressor oil, refrigerant lines of the compressor must be sealed after it is removed.

⚠ CAUTION! ⚠

CAUTION! To avoid equipment damage, DO NOT use these units as a source of heating or cooling during the construction process. The mechanical components and filters will quickly become clogged with construction dirt and debris, which may cause system damage.

GENERAL INFORMATION

Inspection

Upon receipt of the equipment, carefully check the shipment against the bill of lading. Make sure all units have been received. Inspect the packaging of each unit, and inspect each unit for damage. Insure that the carrier makes proper notation of any shortages or damage on all copies of the freight bill and completes a common carrier inspection report. Concealed damage not discovered during unloading must be reported to the carrier within 15 days of receipt of shipment. If not filed within 15 days, the freight company can deny the claim without recourse. Note: It is the responsibility of the purchaser to file all necessary claims with the carrier. Notify your equipment supplier of all damage within fifteen (15) days of shipment.

Storage

Equipment should be stored in its original packaging in a clean, dry area. Store units in an upright position at all times. Stack units a maximum of 3 units high.

Unit Protection

Cover units on the job site with either the original packaging or an equivalent protective covering. Cap the open ends of pipes stored on the job site. In areas where painting, plastering, and/or spraying has not been completed, all due precautions must be taken to avoid physical damage to the units and contamination by foreign material. Physical damage and contamination may prevent proper start-up and may result in costly equipment clean-up.

Examine all pipes, fittings, and valves before installing any of the system components. Remove any dirt or debris found in or on these components.

Pre-Installation

Installation, Operation, and Maintenance instructions are provided with each unit. Horizontal equipment is designed for installation above false ceiling or in a ceiling plenum. Other unit configurations are typically installed in a mechanical room. The installation site chosen should include adequate service clearance around the unit. Before unit start-up, read all manuals and become familiar with the unit and its operation. Thoroughly check the system before operation.

Prepare units for installation as follows:

1. Compare the electrical data on the unit nameplate with ordering and shipping information to verify that the correct unit has been shipped.
2. Keep the cabinet covered with the original packaging until installation is complete and all plastering, painting, etc. is finished.
3. Verify refrigerant tubing is free of kinks or dents and that it does not touch other unit components.
4. Inspect all electrical connections. Connections must be clean and tight at the terminals.
5. Remove any blower support packaging (water-to-air units only).
6. Loosen compressor bolts on units equipped with compressor spring vibration isolation until the compressor rides freely on the springs. Remove shipping restraints.
7. REMOVE COMPRESSOR SUPPORT PLATE 1/4" SHIPPING BOLTS (2 on each side) TO MAXIMIZE VIBRATION AND SOUND ATTENUATION (R22 units only).
8. Some airflow patterns are field convertible (horizontal units only). Locate the airflow conversion section of this IOM.
9. Locate and verify any hot water generator (HWG), hanger, or other accessory kit located in the compressor section or blower section.

⚠ CAUTION! ⚠

CAUTION! DO NOT store or install units in corrosive environments or in locations subject to temperature or humidity extremes (e.g., attics, garages, rooftops, etc.). Corrosive conditions and high temperature or humidity can significantly reduce performance, reliability, and service life. Always move and store units in an upright position. Tilting units on their sides may cause equipment damage.

NOTICE! Failure to remove shipping brackets from spring-mounted compressors will cause excessive noise, and could cause component failure due to added vibration.

⚠ CAUTION! ⚠

CAUTION! CUT HAZARD - Failure to follow this caution may result in personal injury. Sheet metal parts may have sharp edges or burrs. Use care and wear appropriate protective clothing, safety glasses and gloves when handling parts and servicing heat pumps.

UNIT PHYSICAL DATA

GT-PX Two-Stage (50YD) Series

Model	026	038	049	064	072
Compressor (1 Each)	Copeland UltraTech Two-Stage Scroll				
Factory Charge R410a, oz [kg]	58 [1.64]	78 [2.21]	81 [2.30]	144 [4.08]	156 [4.42]
ECM Fan Motor & Blower Wheel					
Fan Motor Type & Speeds	ECM Variable Speed				
Fan Motor, hp [W]	1/2 [373]	1/2 [373]	1 [746]	1 [746]	1 [746]
Blower Wheel Size (Dia x W), in [mm]	9 x 7 [229 x 178]	11 x 10 [279 x 254]	11 x 10 [279 x 254]	11 x 10 [279 x 254]	11 x 10 [279 x 254]
Water Connection Size					
Swivel - Residential Class	1"	1"	1"	1"	1"
HWG Water Connection Size					
Swivel - Residential Class	1"	1"	1"	1"	1"
Vertical Upflow/Downflow					
Air Coil Dimensions (H x W), in [mm]	28 x 20 [711 x 542]	28 x 25 [711 x 635]	32 x 25 [813 x 635]	36 x 25 [914 x 635]	36 x 25 [914 x 635]
Standard Filter - 2" [51mm] Pleated MERV11 Throwaway, in [mm]	28 x 24 [712 x 610]	28 x 29.5 [712 x 749]	32 x 29.5 [813 x 749]	36 x 29.5 [914 x 749]	36 x 29.5 [914 x 749]
Weight - Operating, lbs [kg]	266 [120.7]	327 [148.6]	416 [189.1]	443 [201.4]	443 [201.4]
Weight - Packaged, lbs [kg]	276 [125.2]	337 [153.2]	426 [193.6]	453 [205.9]	453 [205.9]
Horizontal					
Air Coil Dimensions (H x W), in [mm]	18 x 31 [457 x 787]	20 x 35 [508 x 889]	20 x 40 [508 x 1018]	20 x 45 [508 x 1143]	20 x 45 [508 x 1143]
Standard Filter - 2" [51mm] Pleated MERV11 Throwaway, in [mm]	2 - 18 x 18 [457 x 457]	1 - 12 x 20 [305 x 508] 2 - 20 x 25 [508 x 635]	1 - 18 x 20 [457 x 508] 1 - 20 x 24 [508 x 610]	2 - 20 x 24 [508 x 610]	2 - 20 x 24 [508 x 610]
Weight - Operating, lbs [kg]	266 [120.7]	327 [148.6]	416 [189.1]	443 [201.4]	443 [201.4]
Weight - Packaged, lbs [kg]	276 [125.2]	337 [153.2]	426 [193.6]	453 [205.9]	453 [205.9]

All units have spring compressor mountings, TXV expansion devices, and 1/2" [12.7mm] & 3/4" [19.1mm] electrical knockouts.

GT-PG Single-Stage (50YE) Series

Model	018	024	030	036	042	048	060	070
Compressor (1 Each)	Rotary Copeland Scroll							
Factory Charge R410a, oz [kg]	50 [1.13]	56 [1.59]	58 [1.64]	70 [1.96]	80 [2.27]	80 [2.27]	136 [3.86]	144 [4.08]
ECM Fan Motor & Blower Wheel								
Fan Motor Type & Speeds	ECM Variable Speed							
Fan Motor, hp [W]	1/2 [373]	1/2 [373]	1/2 [373]	1/2 [373]	1/2 [373]	1 [746]	1 [746]	1 [746]
Blower Wheel Size (Dia x W), in [mm]	9 x 7 [229 x 178]	9 x 7 [229 x 178]	9 x 7 [229 x 178]	11 x 10 [279 x 254]	11 x 10 [279 x 254]	11 x 10 [279 x 254]	11 x 10 [279 x 254]	11 x 10 [279 x 254]
Water Connection Size								
Swivel - Residential Class	1"	1"	1"	1"	1"	1"	1"	1"
HWG Water Connection Size								
Swivel - Residential Class	1"	1"	1"	1"	1"	1"	1"	1"
Vertical Upflow/Downflow								
Air Coil Dimensions (H x W), in [mm]	24 x 20 [610 x 508]	28 x 20 [711 x 542]	28 x 20 [711 x 542]	28 x 25 [711 x 635]	32 x 25 [813 x 635]	32 x 25 [813 x 635]	36 x 25 [914 x 635]	36 x 25 [914 x 635]
Standard Filter - 2" [51mm] Pleated MERV11 Throwaway, in [mm]	24 x 24 [610 x 508]	28 x 24 [712 x 610]	28 x 24 [712 x 610]	28 x 30 [711 x 762]	2 - 16 x 30 [406 x 762]	2 - 16 x 30 [406 x 762]	1 - 16 x 30 [406 x 762] 1 - 20 x 30 [508 x 762]	1 - 16 x 30 [406 x 762] 1 - 20 x 30 [508 x 762]
Weight - Operating, lbs [kg]	252 [114]	266 [121]	268 [122]	327 [148]	414 [188]	416 [189]	441 [200]	443 [201]
Weight - Packaged, lbs [kg]	262 [119]	276 [125]	278 [126]	337 [153]	424 [192]	426 [193]	451 [205]	453 [206]
Horizontal								
Air Coil Dimensions (H x W), in [mm]	18 x 27 [457 x 686]	18 x 31 [457 x 787]	18 x 31 [457 x 787]	20 x 35 [508 x 889]	20 x 40 [508 x 1016]	20 x 40 [508 x 1016]	20 x 45 [508 x 1143]	20 x 45 [508 x 1143]
Standard Filter - 2" [51mm] Pleated MERV11 Throwaway, in [mm]	2 - 18 x 18 [457 x 457]	2 - 18 x 18 [457 x 457]	2 - 18 x 18 [457 x 457]	1 - 12 x 20 [305 x 508] 1 - 20 x 25 [508 x 635]	1 - 18 x 20 [457 x 508] 1 - 20 x 24 [508 x 610]	1 - 18 x 20 [457 x 508] 1 - 20 x 24 [508 x 610]	2 - 20 x 24 [508 x 610]	2 - 20 x 24 [508 x 610]
Weight - Operating, lbs [kg]	252 [114]	266 [121]	268 [122]	327 [148]	414 [188]	416 [189]	441 [200]	443 [201]
Weight - Packaged, lbs [kg]	262 [119]	276 [125]	278 [126]	337 [153]	424 [192]	426 [193]	451 [205]	453 [206]

All units have spring compressor mountings, TXV expansion devices, and 1/2" [12.7mm] & 3/4" [19.1mm] electrical knockouts.

UNIT PHYSICAL DATA

GT-G Packaged (GT-G) Series

Model	015	018	024	030	036	042	048	060	070
Compressor (1 Each)	Rotary		Copeland Scroll						
Factory Charge R22, oz [kg]	44 [1.25]	44 [1.25]	48 [1.36]	48 [1.36]	60 [1.70]	74 [2.0]	74 [2.10]	102 [2.89]	104 [2.95]
PSC Fan Motor & Blower Wheel									
Fan Motor Type & Speeds	PSC/3								
Fan Motor, hp [W]	1/6 [124]	1/6 [124]	1/5 [150]	1/3 [250]	1/2 [373]	1/2 [373]	3/4 [560]	1/6 [124]	1 [746]
Blower Wheel Size (Dia x W), in [mm]	9 x 7 [229 x 178]	9 x 7 [229 x 178]	9 x 7 [229 x 178]	9 x 7 [229 x 178]	9 x 7 [229 x 178]	10 x 10 [254 x 254]	10 x 10 [254 x 254]	11 x 10 [279 x 254]	11 x 10 [279 x 254]
ECM Fan Motor & Blower Wheel									
Fan Motor Type & Speeds	ECM Variable Speed								
Fan Motor, hp [W]	1/2 [373]	1/2 [373]	1/2 [373]	1/2 [373]	1/2 [373]	1/2 [373]	1 [746]	1 [746]	1 [746]
Blower Wheel Size (Dia x W), in [mm]	9 x 7 [229 x 178]	9 x 7 [229 x 178]	9 x 7 [229 x 178]	9 x 7 [229 x 178]	9 x 7 [229 x 178]	11 x 10 [279 x 254]	11 x 10 [279 x 254]	11 x 10 [279 x 254]	11 x 10 [279 x 254]
Water Connection Size									
Swivel - Residential Class	1"	1"	1"	1"	1"	1"	1"	1"	1"
HWG Water Connection Size									
Swivel - Residential Class	1"	1"	1"	1"	1"	1"	1"	1"	1"
Vertical Upflow/Downflow									
Air Coil Dimensions (H x W), in [mm]	20 x 20 [508 x 508]	20 x 20 [508 x 508]	24 x 20 [588 x 542]	24 x 20 [588 x 542]	28 x 20 [712 x 508]	28 x 25 [712 x 635]	28 x 25 [712 x 635]	32 x 25 [802 x 635]	36 x 25 [914 x 635]
Standard Filter - 1" [25.4mm] Throwaway, in [mm]	20 x 24 [508 x 588]	20 x 24 [508 x 588]	24 x 24 [610 x 610]	24 x 24 [610 x 610]	2 - 14 x 24 [343 x 610]	2 - 14 x 30 [343 x 762]	2 - 14 x 30 [343 x 762]	2 - 10 x 30 [254 x 762] 1 - 12 x 30 [305 x 762]	3 - 12 X 30 [305 X 762]
Weight - Operating, lbs [kg]	174 [79]	184 [83]	250 [113]	252 [114]	266 [121]	323 [147]	327 [148]	416 [186]	443 [201]
Weight - Packaged, lbs [kg]	184 [83]	194 [88]	260 [118]	262 [119]	276 [125]	333 [151]	337 [153]	426 [193]	453 [205]
Horizontal									
Air Coil Dimensions (H x W), in [mm]	18 X 22 [457 x 539]	18 X 22 [457 x 539]	18 x 27 [457 x 686]	18 x 27 [457 x 686]	18 x 31 [457 x 782]	20 x 35 [508 x 858]	20 x 35 [508 x 858]	20 x 40 [508 x 1016]	20 x 45 [508 x 1143]
Standard Filter - 2" [51mm] Throwaway, in [mm]	18 x 24 [457 x 588]	18 x 24 [457 x 588]	2 - 18 x 18 [457 x 457]	2 - 18 x 18 [457 x 457]	2 - 18 x 18 [457 x 457]	2 - 12 x 20 [305 x 508] 1 - 20 x 25 [508 x 635]	2 - 12 x 20 [305 x 508] 1 - 20 x 25 [508 x 635]	1 - 18 x 20 [457 x 508] 1 - 24 x 20 [588 x 508]	2 - 24 x 20 [610 x 508]
Weight - Operating, lbs [kg]	179 [79]	189 [83]	250 [113]	252 [114]	266 [121]	323 [147]	327 [148]	416 [186]	443 [201]
Weight - Packaged, lbs [kg]	189 [83]	199 [88]	260 [118]	262 [119]	276 [125]	333 [151]	337 [153]	426 [193]	453 [206]

All units have spring compressor mountings, TXV expansion devices, and 1/2" [12.7mm] & 3/4" [19.1mm] electrical knockouts.

DIMENSIONS — VERTICAL UPFLOW GT-PX (50YD) SERIES

Vertical Upflow Model	Overall Cabinet			Water Connections							Electrical Knockouts			Discharge Connection					Return Connection				
				1	2	3	4	5	Loop Water IPT	HWG IPT	J	K	L	duct flange installed (+/- 0.10 in. +/- 2.5mm)					std. deluxe filter rack (+/- 0.10 in. +/- 2.5mm)				
	D In	E Out	F HWG In	G HWG Out	H Condensate	1/2" cond Low Voltage	1/2" cond Ext Pump	3/4" cond Power Supply			M (LH rtn)	N	O Supply Width	P Supply Depth	Q (RH rtn)	R	S Return Depth	T Return Height	U				
026	in.	22.4	25.6	48.5	2.1	10.0	13.9	16.9	7.8	1" Swivel	1" Swivel	3.6	6.1	8.6	7.2	5.8	14.0	14.0	4.9	1.7	22.2	26.2	1.5
	cm.	56.8	65.1	123.2	5.2	25.4	35.2	42.9	19.8			9.2	15.6	21.9	18.3	14.8	35.6	35.6	12.4	4.2	56.4	66.4	3.9
038	in.	25.4	30.6	50.5	3.4	10.8	15.6	18.9	7.8	1" Swivel	1" Swivel	3.6	6.1	8.6	6.4	6.3	18.0	18.0	5.3	2.1	27.1	26.1	1.5
	cm.	64.5	77.8	128.3	8.6	27.5	39.7	47.9	19.8			9.2	15.6	21.9	16.1	16.0	45.7	45.7	13.5	5.4	68.9	66.4	3.9
049	in.	25.4	30.6	54.5	3.4	10.8	15.6	18.9	7.8	1" Swivel	1" Swivel	3.6	6.1	8.6	6.4	6.3	18.0	18.0	5.3	2.1	27.1	30.1	1.5
	cm.	64.5	77.8	138.4	8.6	27.5	39.7	47.9	19.8			9.2	15.6	21.9	16.1	16.0	45.7	45.7	13.5	5.4	68.9	76.5	3.9
064	in.	25.4	30.6	58.5	3.4	10.8	15.6	18.9	7.8	1" Swivel	1" Swivel	3.6	6.1	8.6	6.4	6.3	18.0	18.0	5.3	2.1	27.1	34.1	1.5
	cm.	64.5	77.8	148.6	8.6	27.5	39.7	47.9	19.8			9.2	15.6	21.9	16.1	16.0	45.7	45.7	13.5	5.4	68.9	86.7	3.9
072	in.	25.4	30.6	58.5	3.4	10.8	15.6	18.9	7.8	1" Swivel	1" Swivel	3.6	6.1	8.6	6.4	6.3	18.0	18.0	5.3	2.1	27.1	34.1	1.5
	cm.	64.5	77.8	148.6	8.6	27.5	39.7	47.9	19.8			9.2	15.6	21.9	16.1	16.0	45.7	45.7	13.5	5.4	68.9	86.7	3.9

Condensate is 3/4" PVC female glue socket and is switchable from front to side.
 Unit shipped with deluxe duct collar/filter rack extending from unit 3" (7.6cm) and is suitable for duct connection.
 Discharge flange field installed.

Rev: 21 Aug. 2007D

Legend
 CAP=Control Access Panel
 CSP=Compressor Service Panel
 BSP=Blower Service Panel
 ASP=Alternate Service Panel

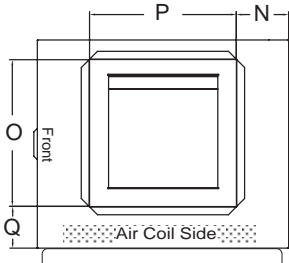

Top View-Right Return

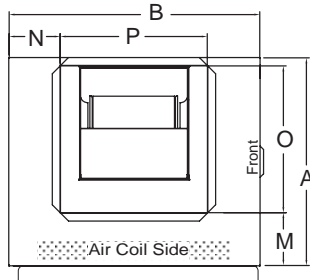

Top View-Left Return

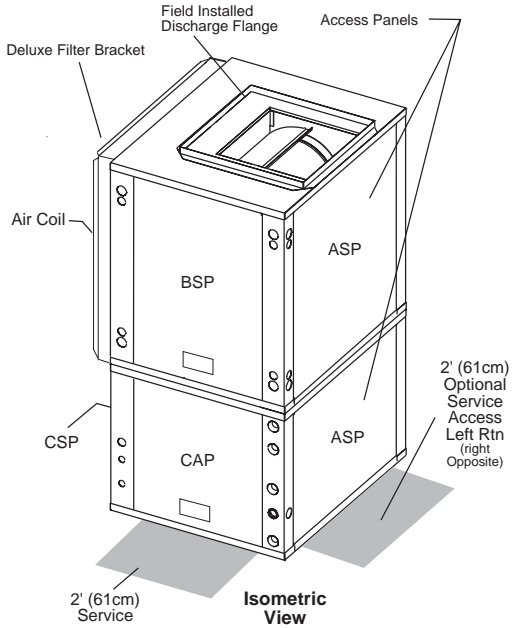

Isometric View

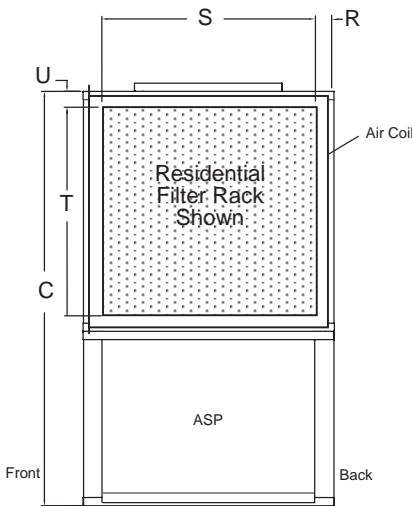

Right Return Right View - Filter Rack Knife Edge

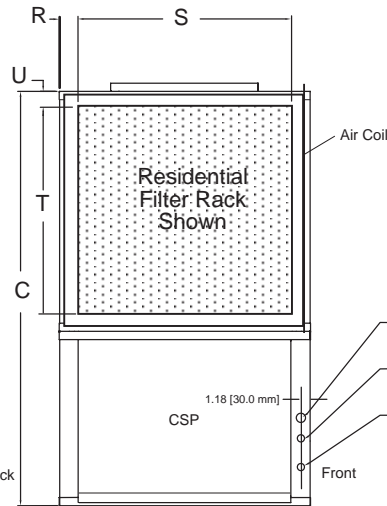

Left Return Left View - Filter Rack Knife Edge

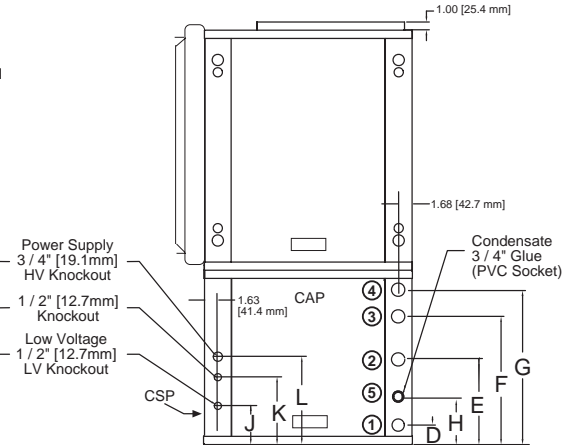

Front-View

DIMENSIONS — VERTICAL DOWNFLOW GT-PX (50YD) SERIES

Vertical Downflow Model	Overall Cabinet			Water Connections					Electrical Knockouts			Discharge Connection					Return Connection						
				1	2	3	4	5	J	K	L	duct flange installed (+/- 0.10 in, +/- 2.5mm)					std. deluxe filter rack (+/- 0.10 in, +/- 2.5mm)						
	A	B	C	D	E	F	G	H	Loop Water IPT	HWG IPT		1/2" cond Low Voltage	1/2" cond Ext Pump	3/4" cond Power Supply	M (LH rtn)	N	O Supply Width	P Supply Depth	Q (RH rtn)	R	S	T	U
026	in.	22.4	25.6	52.5	2.1	10.0	13.9	16.9	3.6	1" Swivel	1" Swivel	3.6	6.1	8.6	6.7	8.4	9.9	9.1	1.5	1.7	22.2	26.2	21.2
	cm.	56.8	65.1	133.4	5.2	25.4	35.2	42.9	9.2			9.2	15.6	21.9	17.1	21.4	25.3	23.0	3.9	4.2	56.4	66.4	53.9
038	in.	25.4	30.6	54.5	3.4	10.8	15.6	18.9	3.6	1" Swivel	1" Swivel	3.6	6.1	8.6	7.4	9.0	13.1	12.9	1.6	1.7	27.2	26.2	23.2
	cm.	64.5	77.8	138.4	8.6	27.5	39.7	47.9	9.2			9.2	15.6	21.9	18.7	22.9	33.3	32.7	4.1	4.2	69.1	66.4	59.0
049	in.	25.4	30.6	58.5	3.4	10.8	15.6	18.9	3.6	1" Swivel	1" Swivel	3.6	6.1	8.6	7.4	9.0	13.1	12.9	1.6	1.7	27.2	30.2	23.2
	cm.	64.5	77.8	148.6	8.6	27.5	39.7	47.9	9.2			9.2	15.6	21.9	18.7	22.9	33.3	32.7	4.1	4.2	69.1	76.6	59.0
064	in.	25.4	30.6	62.5	3.4	10.8	15.6	18.9	3.6	1" Swivel	1" Swivel	3.6	6.1	8.6	7.4	9.0	13.1	12.9	1.6	1.7	27.2	34.2	23.2
	cm.	64.5	77.8	158.8	8.6	27.5	39.7	47.9	9.2			9.2	15.6	21.9	18.7	22.9	33.3	32.7	4.1	4.2	69.1	86.8	59.0
072	in.	25.4	30.6	62.5	3.4	10.8	15.6	18.9	3.6	1" Swivel	1" Swivel	3.6	6.1	8.6	7.4	9.0	13.1	12.9	1.6	1.7	27.2	34.2	23.2
	cm.	64.5	77.8	158.8	8.6	27.5	39.7	47.9	9.2			9.2	15.6	21.9	18.7	22.9	33.3	32.7	4.1	4.2	69.1	86.8	59.0

Condensate is 3/4" PVC female glue socket and is switchable from front to side.
 Unit shipped with deluxe duct collar/filter rack extending from unit 3" (7.6cm) and is suitable for duct connection.
 Downflow unit does not have discharge flange, and is rated for zero clearance installation.

Rev.: 21 Aug. 2007D

Legend
 CAP=Control Access Panel
 CSP=Compressor Service Panel
 BSP=Blower Service Panel
 ASP=Alternate Service Panel

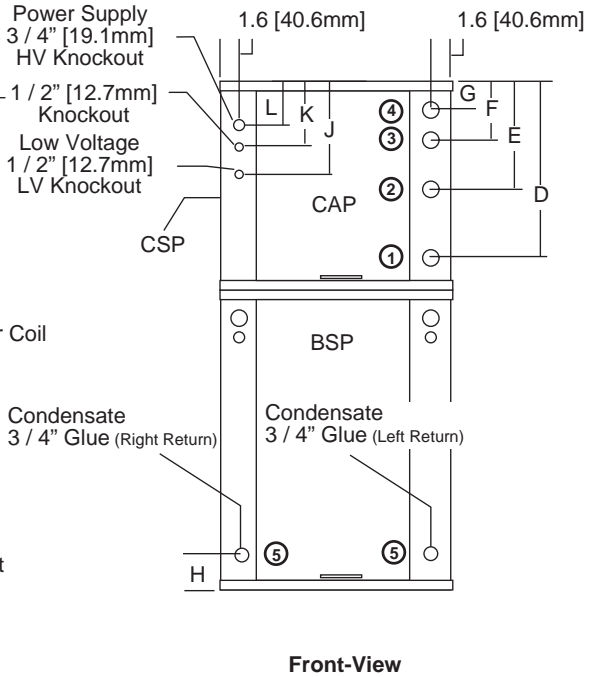
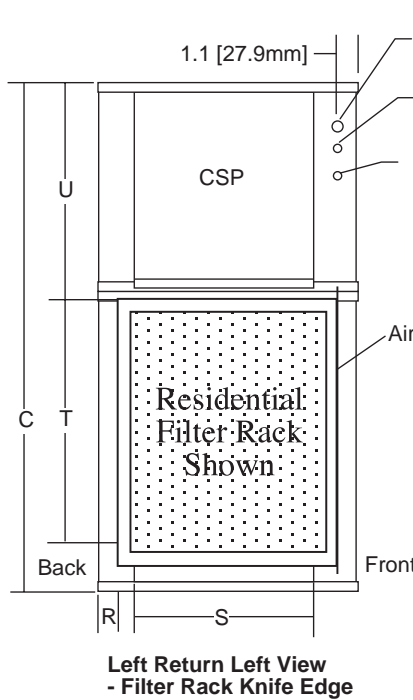
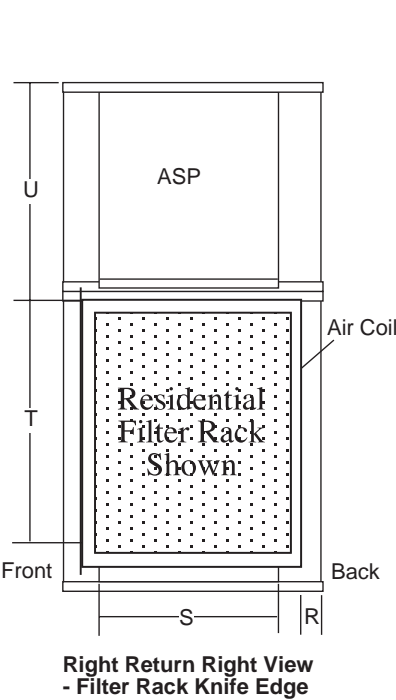
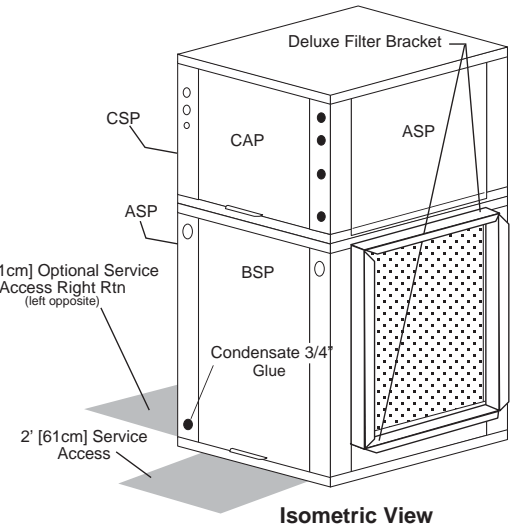
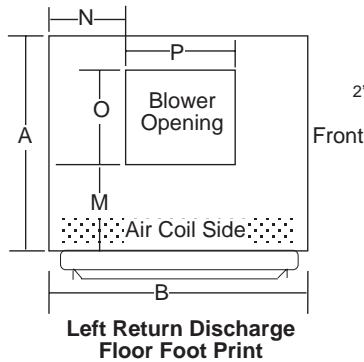
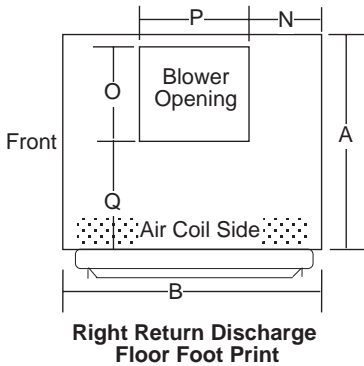

DIMENSIONS — HORIZONTAL GT-PX (50YD) SERIES

Horizontal Model	Overall Cabinet			Water Connections							Electrical Knockouts			Discharge Connection					Return Connection					
				1	2	3	4	5	J	K	L	duct flange installed (+/- 0.10 in. +/- 2.5mm)					std. deluxe filter rack (+/- 0.10 in. +/- 2.5mm)							
	A	B	C	D	E	F	G	H	Loop Water IPT	HWG IPT	1/2" cond Low Voltage	1/2" cond Ext Pump	3/4" cond Power Supply	M (LH rtm)	N	O Supply Width	P Supply Depth	Q (RH rtm)	R	S	T	U	V	
026	in.	22.4	62.2	19.3	2.1	10.0	13.9	16.9	0.6	1" Swivel	1" Swivel	3.6	6.1	8.6	3.6	2.0	12.5	15.5	3.6	2.0	33.8	16.2	2.3	1.5
	cm.	56.8	158.0	48.9	5.2	25.4	35.2	42.9	1.5			9.2	15.6	21.9	9.3	5.1	31.8	39.4	9.2	5.2	85.8	41.0	5.8	3.9
038	in.	25.4	71.2	21.3	3.4	10.8	15.6	18.9	0.6	1" Swivel	1" Swivel	3.4	6.1	8.6	3.1	1.2	19.0	17.5	3.1	1.0	34.8	18.2	3.1	1.5
	cm.	64.5	180.8	54.0	8.6	27.5	39.7	47.9	1.5			8.6	15.6	21.9	8.0	3.1	48.3	44.5	8.0	2.6	88.3	46.1	7.8	3.9
049	in.	25.4	76.2	21.3	3.4	10.8	15.6	18.9	0.6	1" Swivel	1" Swivel	3.6	6.1	8.6	3.1	1.2	19.0	17.5	3.1	1.0	39.8	18.2	3.1	1.5
	cm.	64.5	193.5	54.0	8.6	27.5	39.7	47.9	1.5			9.2	15.6	21.9	8.0	3.1	48.3	44.5	8.0	2.6	101.0	46.1	7.8	3.9
064	in.	25.4	81.2	21.3	3.4	10.8	15.6	18.9	0.6	1" Swivel	1" Swivel	3.6	6.1	8.6	3.1	1.2	19.0	17.5	3.1	1.0	44.8	18.2	3.1	1.5
	cm.	64.5	206.2	54.0	8.6	27.5	39.7	47.9	1.5			9.2	15.6	21.9	8.0	3.1	48.3	44.5	8.0	2.6	113.7	46.1	7.8	3.9
072	in.	25.4	81.2	21.3	3.4	10.8	15.6	18.9	0.6	1" Swivel	1" Swivel	3.6	6.1	8.6	3.1	1.2	19.0	17.5	3.1	1.0	44.8	18.2	3.1	1.5
	cm.	64.5	206.2	54.0	8.6	27.5	39.7	47.9	1.5			9.2	15.6	21.9	8.0	3.1	48.3	44.5	8.0	2.6	113.7	46.1	7.8	3.9

Condensate is stainless steel 3/4" IPT.
 Unit shipped with deluxe duct collar/filter rack extending from unit 3" (7.6cm) and is suitable for duct connection.
 Discharge flange factory installed.

Rev: 21 Aug. 2007D

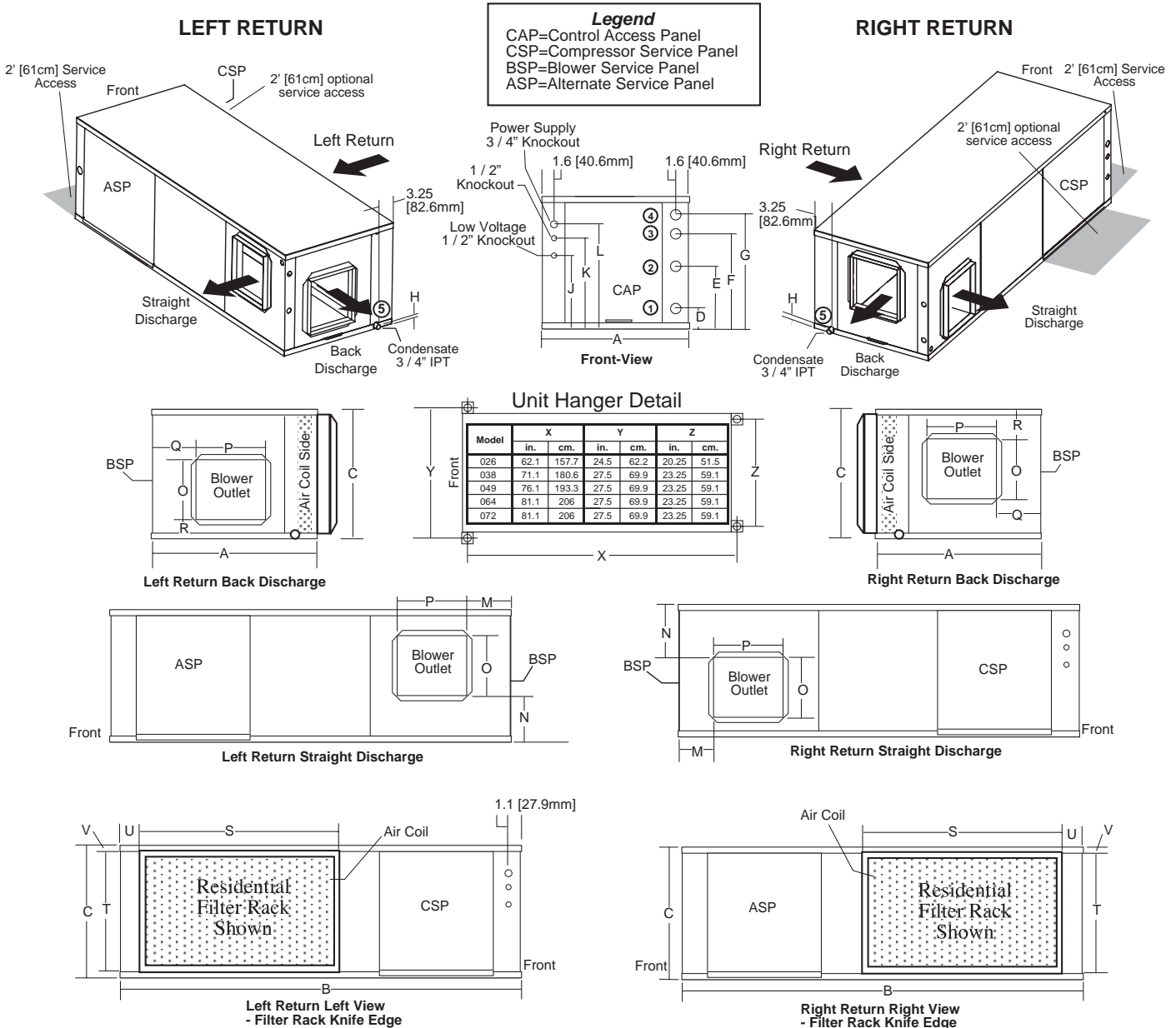

DIMENSIONS — VERTICAL UPFLOW GT-PG (50YE) SERIES

Vertical Upflow Model	Overall Cabinet			Water Connections					Electrical Knockouts			Discharge Connection					Return Connection						
				1	2	3	4	5	J	K	L	duct flange installed (+/- 0.10 in, +/- 2.5mm)					std. deluxe filter rack (+/- 0.10 in, +/- 2.5mm)						
	A	B	C	D	E	F	G	H	Loop Water IPT	HWG IPT	Low Voltage	Ext Pump	Power Supply	M	N	O	P	Q	R	S	T	U	
018	in.	22.4	25.6	44.6	2.1	10.0	13.9	16.9	7.8	1" Swivel	1" Swivel	3.6	6.1	8.6	7.2	5.8	14.0	14.0	4.9	1.7	22.2	26.2	1.5
	cm.	56.8	65.1	123.2	5.2	25.4	35.2	42.9	19.8			9.2	15.6	21.9	18.3	14.8	35.6	35.6	12.4	4.2	56.4	66.4	3.9
024 - 030	in.	22.4	25.6	48.5	2.1	10.0	13.9	16.9	7.8	1" Swivel	1" Swivel	3.6	6.1	8.6	7.2	5.8	14.0	14.0	4.9	1.7	22.2	26.2	1.5
	cm.	56.8	65.1	123.2	5.2	25.4	35.2	42.9	19.8			9.2	15.6	21.9	18.3	14.8	35.6	35.6	12.4	4.2	56.4	66.4	3.9
036	in.	25.4	30.6	50.5	3.4	10.8	15.6	18.9	7.8	1" Swivel	1" Swivel	3.6	6.1	8.6	6.4	6.3	18.0	18.0	5.3	2.1	27.1	26.1	1.5
	cm.	64.5	77.8	128.3	8.6	27.5	39.7	47.9	19.8			9.2	15.6	21.9	16.1	16.0	45.7	45.7	13.5	5.4	68.9	66.4	3.9
042 - 048	in.	25.4	30.6	54.5	3.4	10.8	15.6	18.9	7.8	1" Swivel	1" Swivel	3.6	6.1	8.6	6.4	6.3	18.0	18.0	5.3	2.1	27.1	30.1	1.5
	cm.	64.5	77.8	138.4	8.6	27.5	39.7	47.9	19.8			9.2	15.6	21.9	16.1	16.0	45.7	45.7	13.5	5.4	68.9	76.5	3.9
060 - 070	in.	25.4	30.6	58.5	3.4	10.8	15.6	18.9	7.8	1" Swivel	1" Swivel	3.6	6.1	8.6	6.4	6.3	18.0	18.0	5.3	2.1	27.1	34.1	1.5
	cm.	64.5	77.8	148.6	8.6	27.5	39.7	47.9	19.8			9.2	15.6	21.9	16.1	16.0	45.7	45.7	13.5	5.4	68.9	86.7	3.9

Condensate is 3/4" PVC glue socket and is switchable from front to side.
 Unit shipped with deluxe duct collar/filter rack extending from unit 3" (7.6cm) and is suitable for duct connection.
 Discharge flange field installed.

Rev. 02/25/05D

Legend
 CAP=Control Access Panel
 CSP=Compressor Service Panel
 BSP=Blower Service Panel
 ASP=Alternate Service Panel

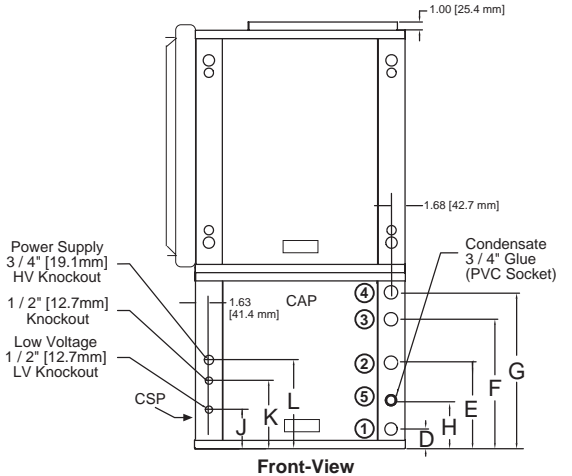
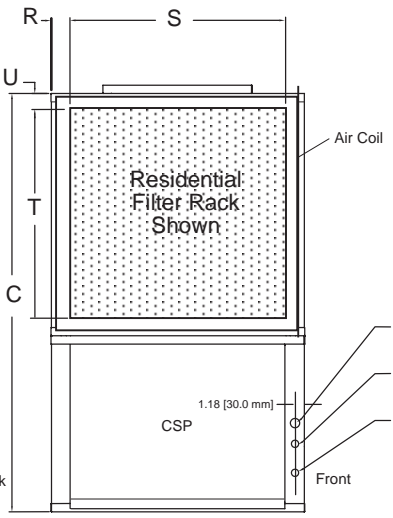
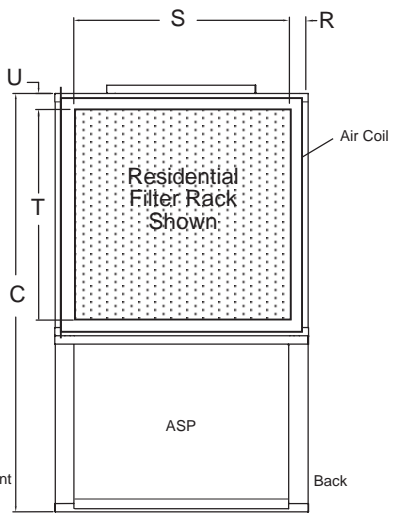
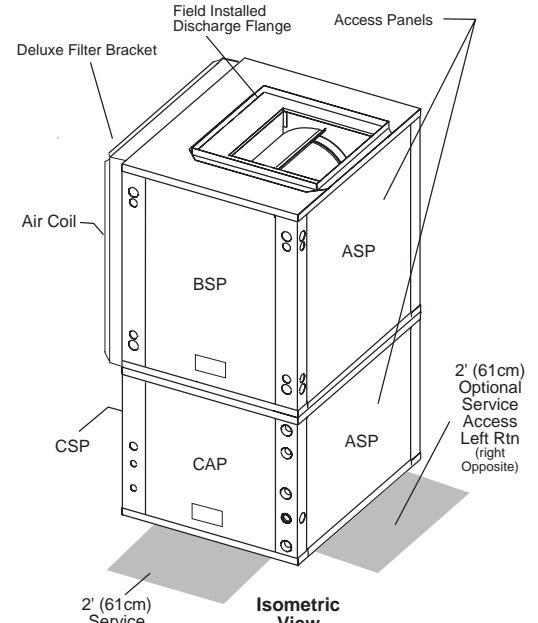
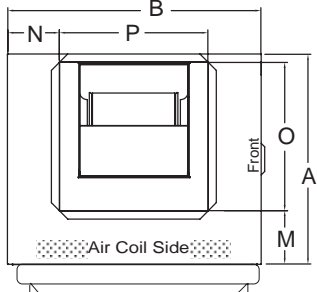
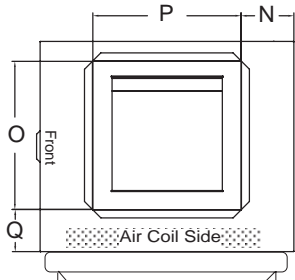

DIMENSIONS — VERTICAL DOWNFLOW GT-PX (50YD) SERIES

Vertical Downflow Model	Overall Cabinet			Water Connections					Electrical Knockouts			Discharge Connection					Return Connection						
				1	2	3	4	5	Loop Water IPT	HWG IPT	J	K	L	duct flange installed (+/- 0.10 in, +/- 2.5mm)			std. deluxe filter rack (+/- 0.10 in, +/- 2.5mm)						
	A	B	C	D	E	F	G	H			1/2" cond	1/2" cond	3/4" cond	M	N	O	P	Q	R	S	T	U	
Width	Depth	Height	In	Out	HWG In	HWG Out	Condensate	Low Voltage	Ext Pump	Power Supply	(LH rtn)		Supply Width	Supply Depth	(RH rtn)		Return Depth	Return Height					
018	in. cm.	22.4 56.8	25.6 65.1	48.6 123.4	2.1 5.2	10.0 25.4	13.9 35.2	16.9 42.9	3.6 9.2	1" Swivel	1" Swivel	3.6 9.2	6.1 15.6	8.6 21.9	6.7 17.1	8.4 21.4	9.9 25.3	9.1 23.0	1.5 3.9	1.7 4.2	22.2 56.4	22.2 56.4	21.2 53.9
024-030	in. cm.	22.4 56.8	25.6 65.1	52.5 133.4	2.1 5.2	10.0 25.4	13.9 35.2	16.9 42.9	3.6 9.2	1" Swivel	1" Swivel	3.6 9.2	6.1 15.6	8.6 21.9	6.7 17.1	8.4 21.4	9.9 25.3	9.1 23.0	1.5 3.9	1.7 4.2	22.2 56.4	26.2 66.4	21.2 53.9
036	in. cm.	25.4 64.5	30.6 77.8	54.5 138.4	3.4 8.6	10.8 27.5	15.6 39.7	18.9 47.9	3.6 9.2	1" Swivel	1" Swivel	3.6 9.2	6.1 15.6	8.6 21.9	7.4 18.7	9.0 22.9	13.1 33.3	12.9 32.7	1.6 4.1	1.7 4.2	27.2 69.1	26.2 66.4	23.2 59.0
042-048	in. cm.	25.4 64.5	30.6 77.8	58.5 148.6	3.4 8.6	10.8 27.5	15.6 39.7	18.9 47.9	3.6 9.2	1" Swivel	1" Swivel	3.6 9.2	6.1 15.6	8.6 21.9	7.4 18.7	9.0 22.9	13.1 33.3	12.9 32.7	1.6 4.1	1.7 4.2	27.2 69.1	30.2 76.6	23.2 59.0
060-070	in. cm.	25.4 64.5	30.6 77.8	62.5 158.8	3.4 8.6	10.8 27.5	15.6 39.7	18.9 47.9	3.6 9.2	1" Swivel	1" Swivel	3.6 9.2	6.1 15.6	8.6 21.9	7.4 18.7	9.0 22.9	13.1 33.3	12.9 32.7	1.6 4.1	1.7 4.2	27.2 69.1	34.2 86.8	23.2 59.0

Condensate is 3/4" PVC glue socket and is switchable from front to side.
Unit shipped with deluxe duct collar/filter rack extending from unit 3" (7.6cm) and is suitable for duct connection.
Downflow unit does not have discharge flange, and is rated for zero clearance installation.

Rev. 02/25/05

Legend
CAP=Control Access Panel
CSP=Compressor Service Panel
BSP=Blower Service Panel
ASP=Alternate Service Panel

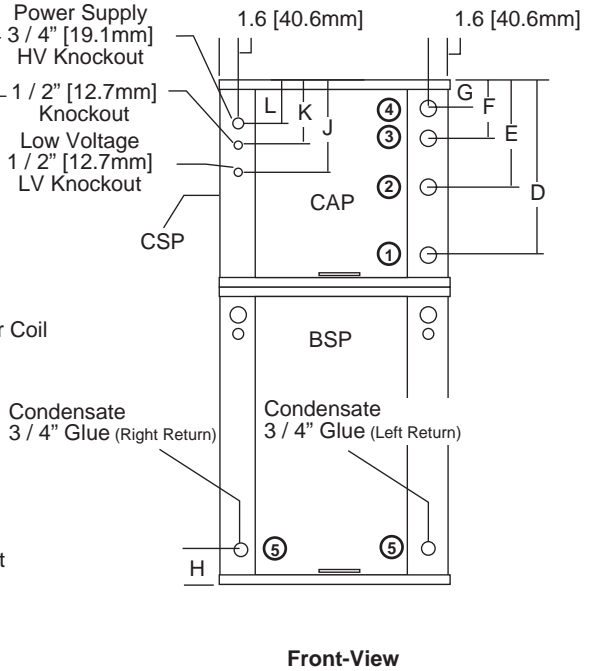
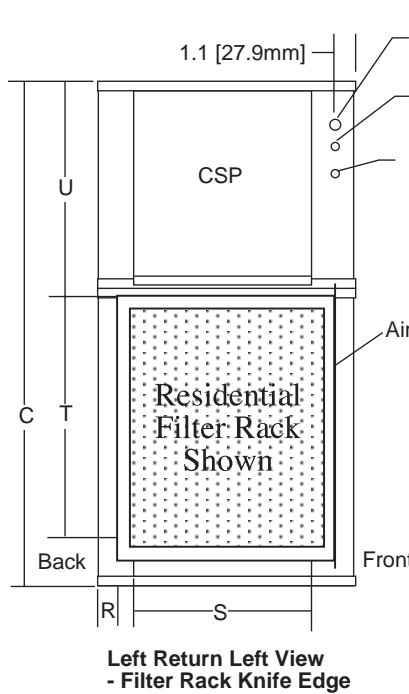
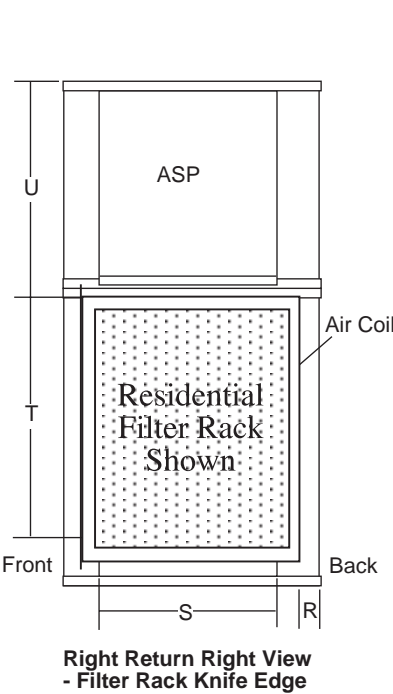
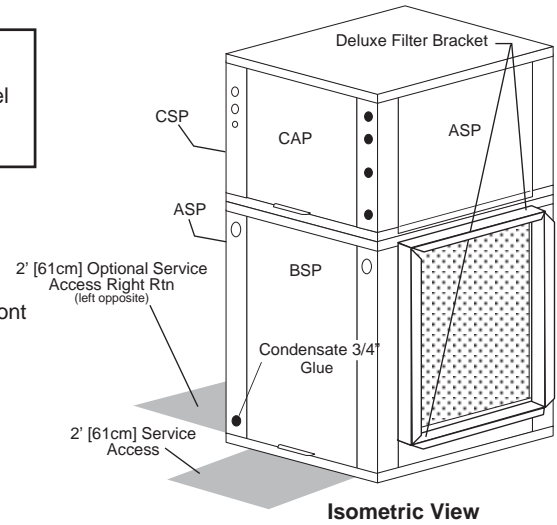
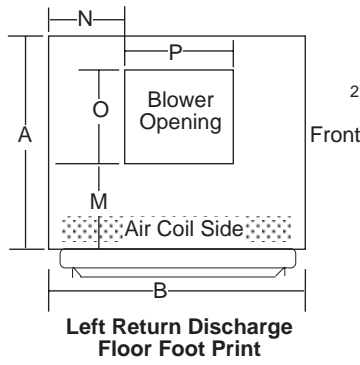
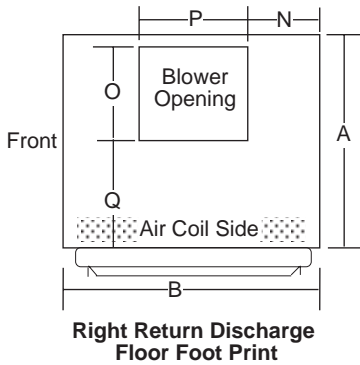

DIMENSIONS — HORIZONTAL GT-PG (50YE) SERIES

Horizontal Model	Overall Cabinet			Water Connections					Electrical Knockouts			Discharge Connection					Return Connection							
				1	2	3	4	5	J	K	L	duct flange installed (+/- 0.10 in. +/- 2.5mm)					std. deluxe filter rack (+/- 0.10 in. +/- 2.5mm)							
	A	B	C	D	E	F	G	H	Loop Water IPT	HWG IPT	1/2" cond Low Voltage	1/2" cond Ext Pump	3/4" cond Power Supply	M	N	O	P	Q	R	S	T	U	V	
018	in.	22.4	62.2	19.3	2.1	10.0	13.9	16.9	0.6	1" Swivel	1" Swivel	3.6	6.1	8.6	5.0	6.8	10.4	9.3	5.0	2.1	28.1	17.3	2.2	1.0
	cm.	56.8	158.0	48.9	5.2	25.4	35.2	42.9	1.5			9.2	15.6	21.9	12.7	17.3	26.4	23.6	12.7	5.3	71.4	43.9	5.6	2.5
024-030	in.	22.4	62.2	19.3	2.1	10.0	13.9	16.9	0.6	1" Swivel	1" Swivel	3.6	6.1	8.6	3.6	2.0	12.5	15.5	3.6	2.0	33.8	16.2	2.3	1.5
	cm.	56.8	158.0	48.9	5.2	25.4	35.2	42.9	1.5			9.2	15.6	21.9	9.3	5.1	31.8	39.4	9.2	5.2	85.8	41.0	5.8	3.9
036	in.	25.4	71.2	21.3	3.4	10.8	15.6	18.9	0.6	1" Swivel	1" Swivel	3.4	6.1	8.6	3.1	1.2	19.0	17.5	3.1	1.0	34.8	18.2	3.1	1.5
	cm.	64.5	180.8	54.0	8.6	27.5	39.7	47.9	1.5			8.6	15.6	21.9	8.0	3.1	48.3	44.5	8.0	2.6	88.3	46.1	7.8	3.9
042-048	in.	25.4	76.2	21.3	3.4	10.8	15.6	18.9	0.6	1" Swivel	1" Swivel	3.6	6.1	8.6	3.1	1.2	19.0	17.5	3.1	1.0	39.8	18.2	3.1	1.5
	cm.	64.5	193.5	54.0	8.6	27.5	39.7	47.9	1.5			9.2	15.6	21.9	8.0	3.1	48.3	44.5	8.0	2.6	101.0	46.1	7.8	3.9
060-070	in.	25.4	81.2	21.3	3.4	10.8	15.6	18.9	0.6	1" Swivel	1" Swivel	3.6	6.1	8.6	3.1	1.2	19.0	17.5	3.1	1.0	44.8	18.2	3.1	1.5
	cm.	64.5	206.2	54.0	8.6	27.5	39.7	47.9	1.5			9.2	15.6	21.9	8.0	3.1	48.3	44.5	8.0	2.6	113.7	46.1	7.8	3.9

Condensate is stainless steel 3/4" IPT.
 Unit shipped with deluxe duct collar/filter rack extending from unit 3" (7.6cm) and is suitable for duct connection.
 Discharge flange factory installed.

Rev. 02/25/09

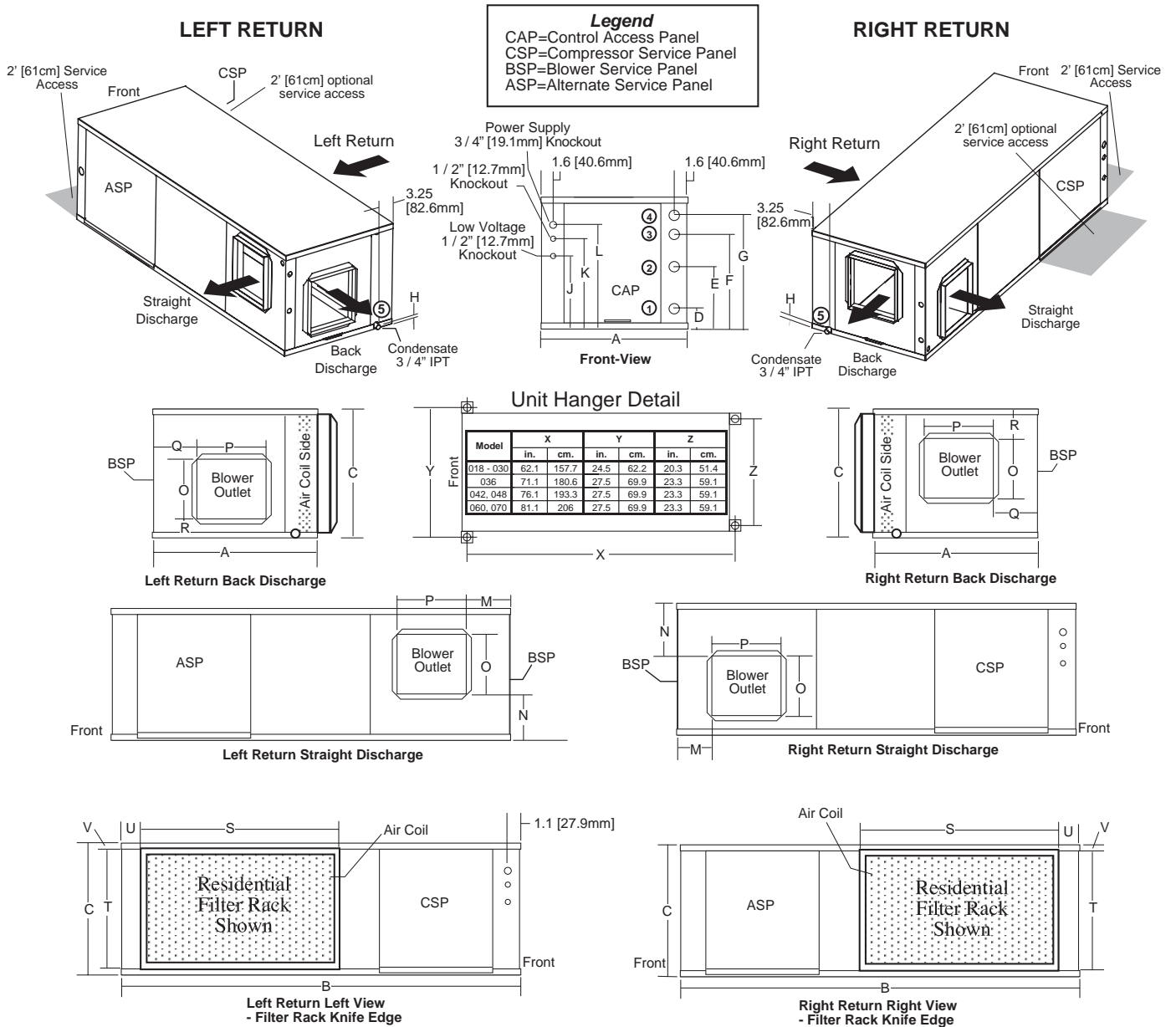

DIMENSIONS — VERTICAL UPFLOW GT-G (50YC) SERIES

Upflow Model	Overall Cabinet			Water Connections								Electric Knockouts			Discharge Connection					Return Connection			
	A	B	C	1	2	3	4	5	Loop Water Swivel	HWG Swivel	J	K	L	M	N	O	P	Q	R	S	T	U	
	Width	Depth	Height	In	Out	HWG In	HWG Out	Condensate			Low Voltage	Ext Pump	Power Supply	Supply Width	Supply Depth					Return Depth	Return Height		
015-018	in. cm.	22.4 56.8	25.6 65.1	40.4 102.6	2.4 6.1	5.4 13.7	13.9 35.3	16.9 42.9	9.8 24.9	1.0	1.0	6.0 15.2	9.5 24.1	12.0 30.5	7.2 18.3	5.8 14.7	14.0 35.6	14.0 35.6	4.3 10.9	1.8 4.6	22.3 56.6	18.2 46.2	1.6 4.1
024-030	in. cm.	22.4 56.8	25.6 65.1	44.4 112.8	2.4 6.1	5.4 13.7	13.9 35.3	16.9 42.9	9.8 24.9	1.0	1.0	6.0 15.2	9.5 24.1	12.0 30.5	7.2 18.3	5.8 14.7	14.0 35.6	14.0 35.6	4.3 10.9	1.8 4.6	22.3 56.6	22.2 56.4	1.6 4.1
036	in. cm.	22.4 56.8	25.6 65.1	48.4 122.9	2.4 6.1	5.4 13.7	13.9 35.3	16.9 42.9	9.8 24.9	1.0	1.0	6.0 15.2	9.5 24.1	12.0 30.5	7.2 18.3	5.8 14.7	14.0 35.6	14.0 35.6	4.3 10.9	1.8 4.6	22.3 56.6	26.2 66.5	1.6 4.1
042-048	in. cm.	25.4 64.5	30.6 77.8	50.4 128.0	2.4 6.1	5.4 13.7	15.9 40.4	18.9 48.0	10.8 27.4	1.0	1.0	8.0 20.3	11.5 29.2	14.0 35.6	6.2 15.7	6.3 16.0	18.0 45.7	18.0 45.7	5.1 13.0	1.5 3.8	27.8 70.6	26.2 66.5	1.5 3.8
060	in. cm.	25.4 64.5	30.6 77.8	54.4 138.2	2.4 6.1	5.4 13.7	15.9 40.4	18.9 48.0	10.8 27.4	1.0	1.0	8.0 20.3	11.5 29.2	14.0 35.6	6.2 15.7	6.3 16.0	18.0 45.7	18.0 45.7	5.1 13.0	1.5 3.8	27.8 70.6	30.2 76.7	1.5 3.8
070	in. cm.	25.4 64.5	30.6 77.8	58.4 148.3	2.4 6.1	5.4 13.7	15.9 40.4	18.9 48.0	10.8 27.4	1.0	1.0	8.0 20.3	11.5 29.2	14.0 35.6	6.2 15.7	6.3 16.0	18.0 45.7	18.0 45.7	5.1 13.0	1.5 3.8	27.8 70.6	34.2 86.9	1.5 3.8

Condensate is 3/4" PVC Glue and is switchable from side to front.

Rev.: 07/19/05D

Unit shipped with deluxe duct collar/filter rack extending from unit 2.5" [64mm] and is suitable for duct connection.

Discharge flange is field installed.

Filter Rack Dimensions

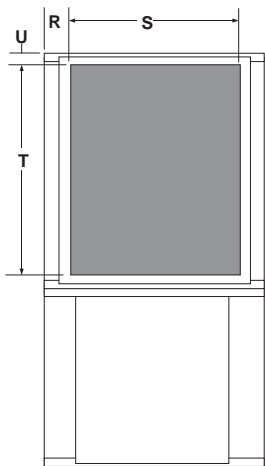

Note: Filter Rack extends out from cabinet 2.75"

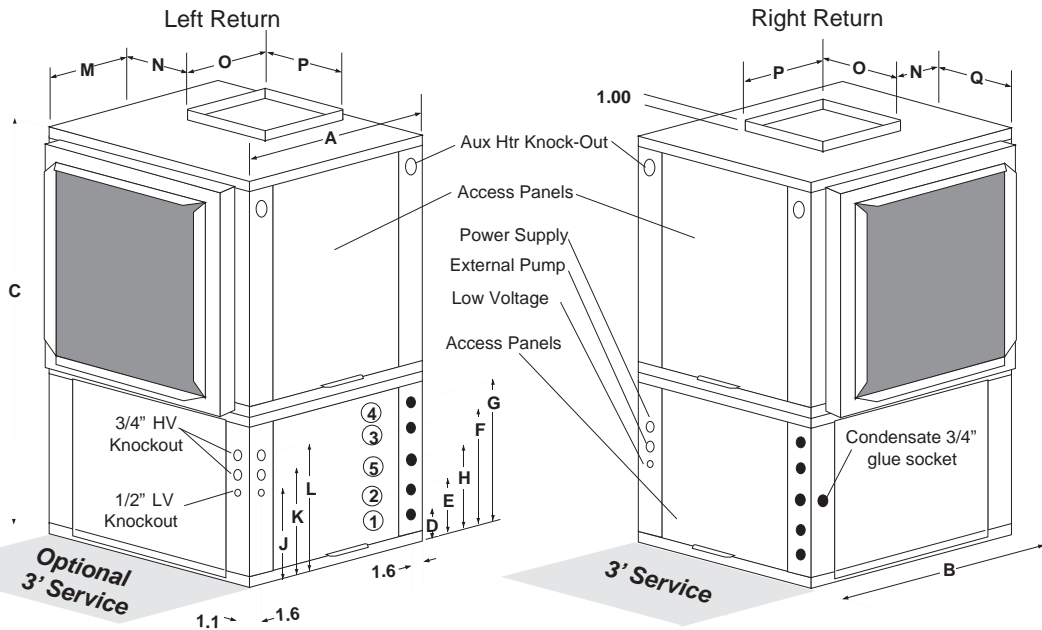

DIMENSIONS — VERTICAL DOWNFLOW GT-G (50YC) SERIES

Downflow Model	Overall Cabinet			Water Connections								Electrical Knockouts			Discharge Connection					Return Connection			
	A	B	C	1	2	3	4	5	Loop Water FPT	HWG FPT	J	K	L	M	N	O	P	Q	R	S	T	U	
	Width	Depth	Height	In	Out	HWG In	HWG Out	Condensate			Low Voltage	Ext Pump	Power Supply	Supply Width	Supply Depth		Return Depth	Return Height					
015-018	in. cm.	22.4 56.8	25.6 65.1	44.4 112.8	17 42.9	14 35.3	5.4 13.7	2.4 6.1	3.6 8.9	1.0 1.0	13.7 33.0	9.7 24.1	7.2 17.8	6.1 15.4	8.2 20.8	10.4 26.4	9.4 23.5	10.9 27.9	1.8 4.6	22.3 56.6	18.2 46.2	21.1 53.6	
024-030	in. cm.	22.4 56.8	25.6 65.1	48.4 122.9	17 42.9	14 35.3	5.4 13.7	2.4 6.1	3.6 8.9	1.0 1.0	13.7 33.0	9.7 24.1	7.2 17.8	6.1 15.4	8.2 20.8	10.4 26.4	9.4 23.5	10.9 27.9	1.8 4.6	22.3 56.6	22.2 56.4	21.1 53.6	
036	in. cm.	22.4 56.8	25.6 65.1	52.4 133.1	17 42.9	14 35.3	5.4 13.7	2.4 6.1	3.6 8.9	1.0 1.0	13.7 33.0	9.7 24.1	7.2 17.8	6.1 15.4	8.2 20.8	10.4 26.4	9.4 23.5	10.9 27.9	1.8 4.6	22.3 56.6	26.2 66.5	21.1 53.6	
042-048	in. cm.	25.4 64.5	30.6 77.8	54.4 138.2	19 48.0	16 40.4	5.4 13.7	2.4 6.1	3.6 8.9	1.0 1.0	13.7 33.0	9.7 24.1	7.2 17.8	7.4 18.3	8.6 22.1	13.6 34.4	13.3 33.7	10.5 27.5	1.5 3.8	27.8 70.6	26.2 66.5	23.1 58.4	
060	in. cm.	25.4 64.5	30.6 77.8	58.4 148.3	19 48.0	16 40.4	5.4 13.7	2.4 6.1	3.6 8.9	1.0 1.0	13.7 33.0	9.7 24.1	7.2 17.8	7.4 18.3	8.6 22.1	13.6 34.4	13.3 33.7	10.5 27.5	1.5 3.8	27.8 70.6	30.2 76.7	23.1 58.4	
070	in. cm.	25.4 64.5	30.6 77.8	62.4 158.5	19 48.0	16 40.4	5.4 13.7	2.4 6.1	3.6 8.9	1.0 1.0	13.7 33.0	9.7 24.1	7.2 17.8	7.4 18.3	8.6 22.1	13.6 34.4	13.3 33.7	10.5 27.5	1.5 3.8	27.8 70.6	34.2 86.9	23.1 58.4	

Condensate is 3/4" PVC Glue and is switchable from side to front.
 Unit shipped with deluxe duct collar/filter rack extending from unit 2.5" [64mm] and is suitable for duct connection.
 Downflow unit does not have discharge flange and is rated for zero clearance installation.

Rev.: 07/19/05D

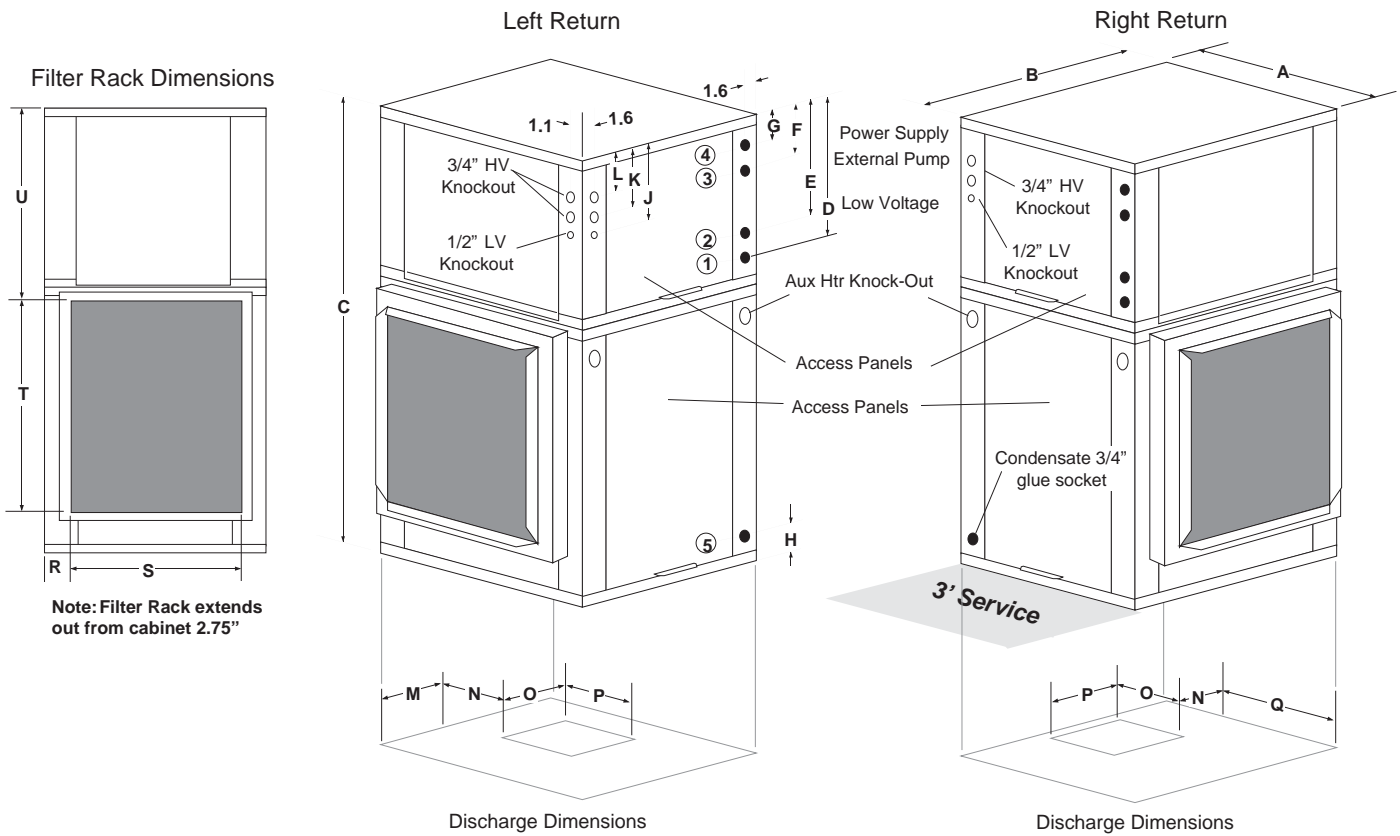

DIMENSIONS — HORIZONTAL GT-G (50YC) SERIES

Horizontal Model	Overall Cabinet			Water Connections*					Electrical Knockouts			Discharge Connection					Return Connection				
				1	2	3	4	5	J	K	L	M	N	O	P	Q	R	S	T	U	V
	A	B	C	D	E	F	G	H	Low Voltage	Ext Pump	Power Supply	Supply Height	Supply Depth			Return Depth	Return Height				
015-018	22.4	53.0	19.3	2.4	5.4	13.9	16.9	0.5	6.0	9.5	12.0	4.3	1.8	10.4	9.3	4.3	1.8	22.1	17.0	2.5	1.0
024-030	22.4	63.0	19.3	2.4	5.4	13.9	16.9	0.5	6.0	9.5	12.0	4.3	1.8	10.4	9.3	4.3	1.8	28.1	17.0	6.5	1.0
036	22.4	63.0	19.3	2.4	5.4	13.9	16.9	0.5	6.0	9.5	12.0	4.3	1.8	10.4	9.3	4.3	1.8	31.1	17.0	3.5	1.0
042-048	25.4	72.0	21.3	2.4	5.4	15.9	18.9	0.5	8.0	11.5	14.0	5.0	1.9	13.6	13.3	5.0	1.9	36.1	19.0	2.5	1.0
060	25.4	77.0	21.3	2.4	5.4	15.9	18.9	0.5	8.0	11.5	14.0	5.0	1.9	13.6	13.3	5.0	1.9	41.1	19.0	2.5	1.0
070	25.4	82.0	21.3	2.4	5.4	15.9	18.9	0.5	8.0	11.5	14.0	5.0	1.9	13.6	13.3	5.0	1.9	46.1	19.0	2.5	1.0

* Water Connections for residential units (distributor class) code are swivel for both water and HWG circuit. Condensate is 3/4" IPT copper. Unit shipped with filter bracket only. Bracket should be removed if connecting to ductwork. Discharge flange and hanger brackets are factory installed.

Rev.: 2/26/01M

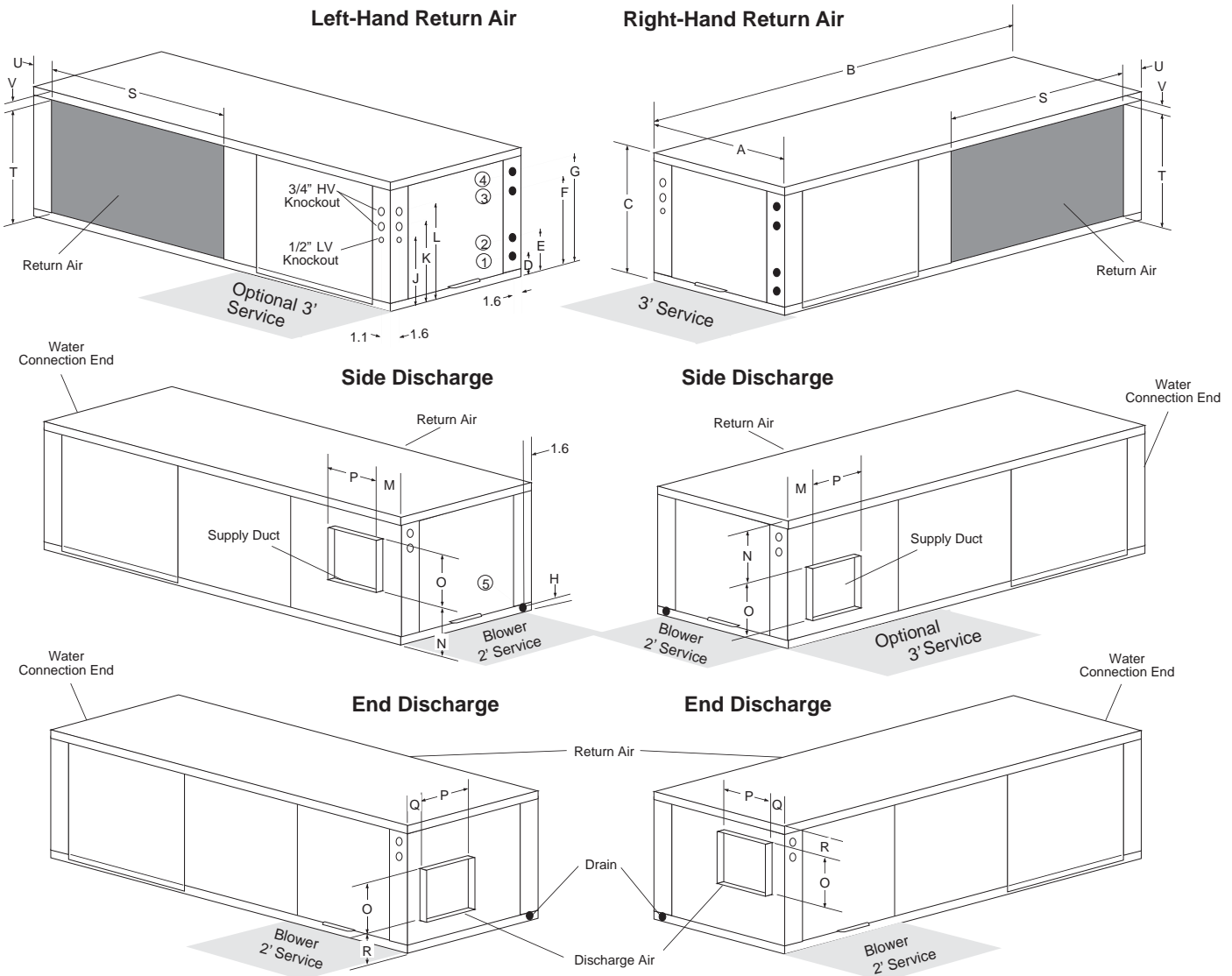

HORIZONTAL INSTALLATION

NOTICE! Failure to remove shipping brackets from spring-mounted compressors will cause excessive noise, and could cause component failure due to added vibration.

Horizontal Unit Location

Units are not designed for outdoor installation. Locate the unit in an INDOOR area that allows enough space for service personnel to perform typical maintenance or repairs without removing unit from the ceiling. Horizontal units are typically installed above a false ceiling or in a ceiling plenum. Never install units in areas subject to freezing or where humidity levels could cause cabinet condensation (such as unconditioned spaces subject to 100% outside air). Consideration should be given to access for easy removal of the filter and access panels. Provide sufficient room to make water, electrical, and duct connection(s).

If the unit is located in a confined space, such as a closet, provisions must be made for return air to freely enter the space by means of a louvered door, etc. Any access panel screws that would be difficult to remove after the unit is installed should be removed prior to setting the unit. Refer to Figure 3 for an illustration of a typical installation. Refer to unit specifications catalog for dimensional data.

Conform to the following guidelines when selecting unit location:

1. Provide a hinged access door in concealed-spline or plaster ceilings. Provide removable ceiling tiles in T-bar or lay-in ceilings. Refer to horizontal unit dimensions for specific series and model in unit specifications catalog. Size the access opening to accommodate the service technician during the removal or replacement of the compressor and the removal or installation of the unit itself.
2. Provide access to hanger brackets, water valves and fittings. Provide screwdriver clearance to access panels, discharge collars and all electrical connections.
3. DO NOT obstruct the space beneath the unit with piping, electrical cables and other items that prohibit future removal of components or the unit itself.
4. Use a manual portable jack/lift to lift and support the weight of the unit during installation and servicing.

The installation of water source heat pump units and all associated components, parts and accessories which make up the installation shall be in accordance with the regulations of ALL authorities having jurisdiction and MUST conform to all applicable codes. It is the responsibility of the installing contractor to determine and comply with ALL applicable codes and regulations.

Mounting Horizontal Units

Horizontal units have hanger kits pre-installed from the factory as shown in figure 1. Figure 3 shows a typical horizontal unit installation.

Horizontal heat pumps are typically suspended above a ceiling or within a soffit using field supplied, threaded rods sized to support the weight of the unit.

Use four (4) field supplied threaded rods and factory provided vibration isolators to suspend the unit. Hang the unit clear of the floor slab above and support the unit by the mounting bracket assemblies only. DO NOT attach the unit flush with the floor slab above.

Pitch the unit toward the drain as shown in Figure 2 to improve the condensate drainage. On small units (less than 2.5 tons/8.8kW) ensure that unit pitch does not cause condensate leaks inside the cabinet.

Figure 1: Hanger Bracket

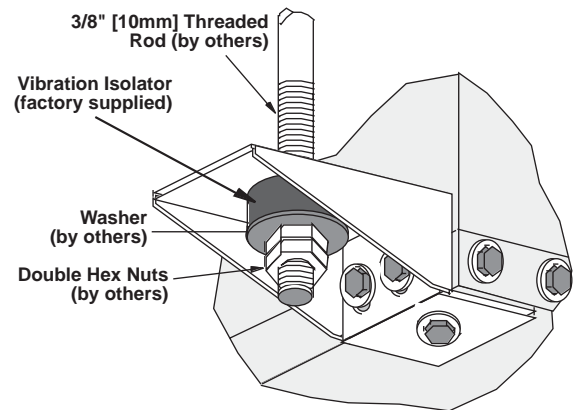
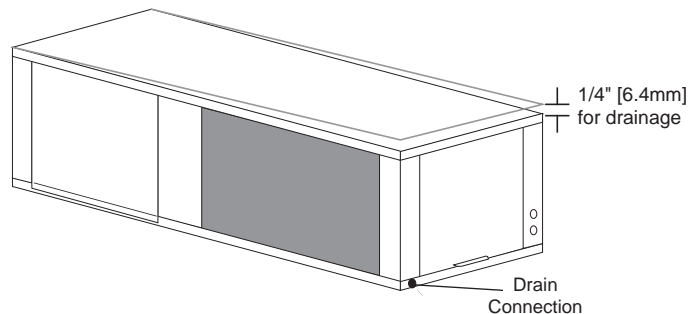
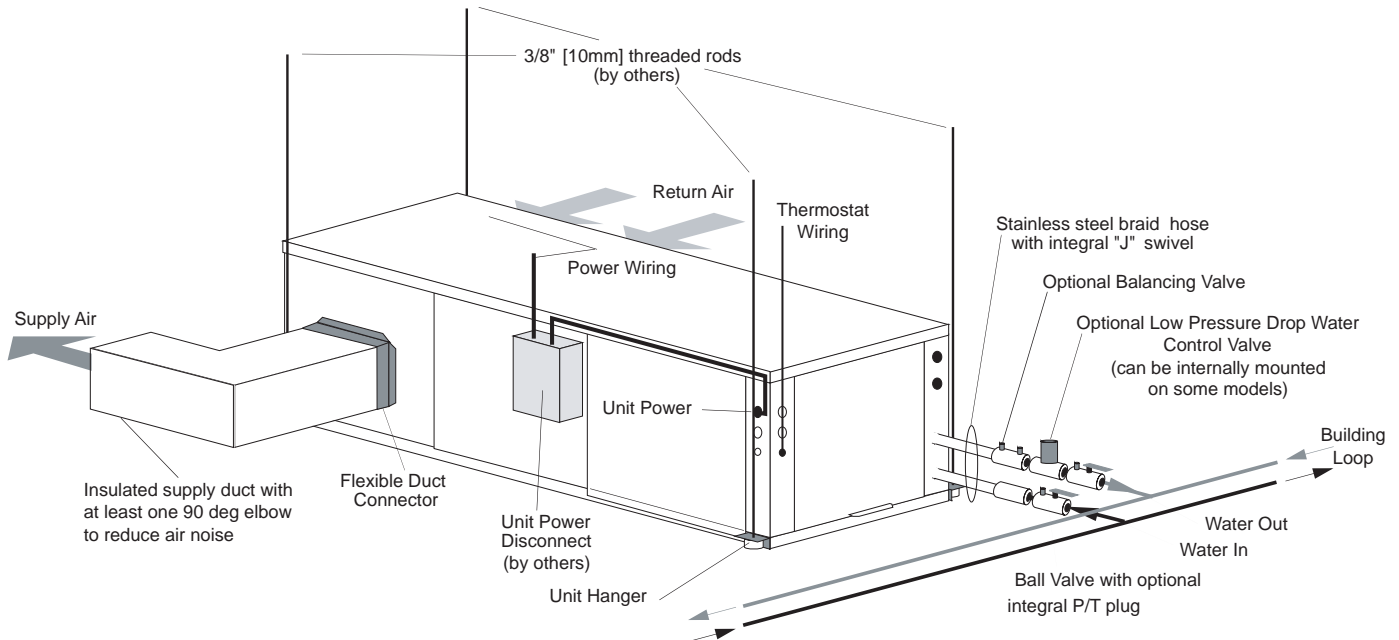

Figure 2: Horizontal Unit Pitch



HORIZONTAL INSTALLATION

Figure 3: Typical Horizontal Unit Installation



Air Coil

To obtain maximum performance, the air coil should be cleaned before start-up. A 10% solution of dishwasher detergent and water is recommended for both sides of the coil. A thorough water rinse should follow. **UV based anti-bacterial systems may damage e-coated air coils.**

NOTICE! Failure to remove shipping brackets from spring-mounted compressors will cause excessive noise, and could cause component failure due to added vibration.

FIELD CONVERSION OF AIR DISCHARGE

Overview

Horizontal units can be field converted between side (straight) and back (end) discharge using the instructions below.

Note: It is not possible to field convert return air between left or right return models due to the necessity of refrigeration copper piping changes.

Preparation

It is best to field convert the unit on the ground before hanging. If the unit is already hung it should be taken down for the field conversion.

Side to Back Discharge Conversion

1. Place unit in well lit area. Remove the screws as shown in Figure 4 to free top panel and discharge panel.
2. Lift out the access panel and set aside. Lift and rotate the discharge panel to the other position as shown, being careful with the blower wiring.
3. Check blower wire routing and connections for tension or contact with sheet metal edges. Reroute if necessary.
4. Check refrigerant tubing for contact with other components.
5. Reinstall top panel and screws noting that the location for some screws will have changed.
6. Manually spin the fan wheel to insure that the wheel is not rubbing or obstructed.
7. Replace access panels.

Back to Side Discharge Conversion

If the discharge is changed from back to side, use above instruction noting that illustrations will be reversed.

Left vs. Right Return

It is not possible to field convert return air between left or right return models due to the necessity of refrigeration copper piping changes. However, the conversion process of side to back or back to side discharge for either right or left return configuration is the same. In some cases, it may be possible to rotate the entire unit 180 degrees if the return air connection needs to be on the opposite side. Note that rotating the unit will move the piping to the other end of the unit.

Figure 4: Left Return Side to Back

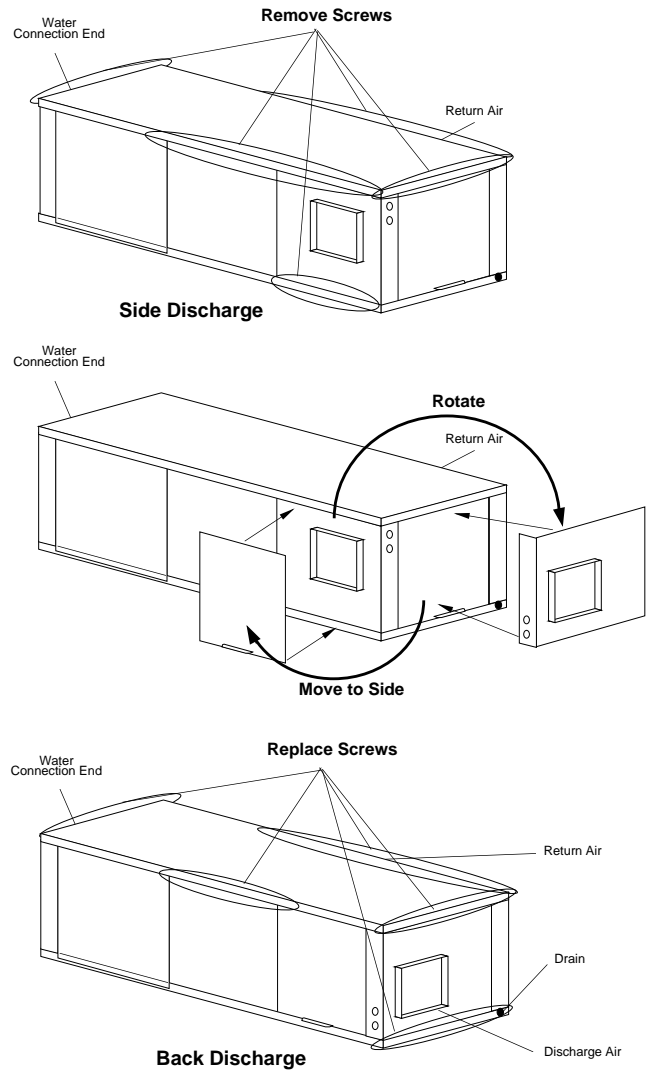
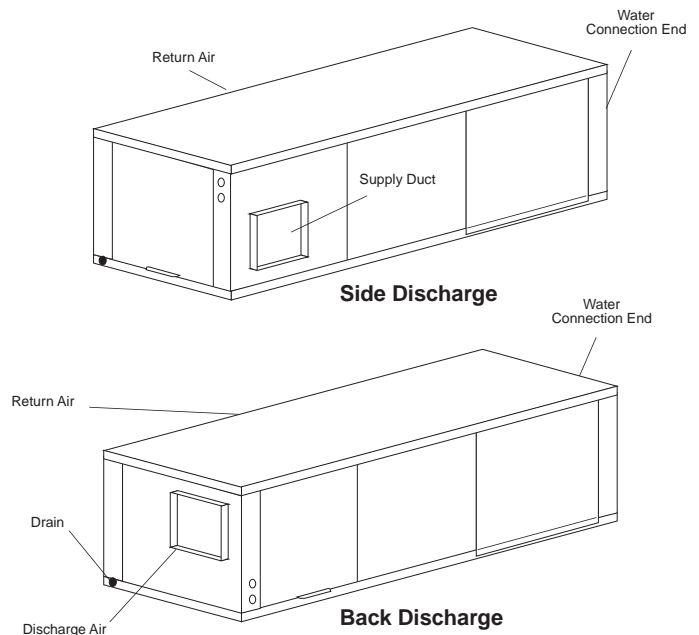

Figure 5: Right Return Side to Back



HORIZONTAL INSTALLATION

Condensate Piping – Horizontal Units

Pitch the unit toward the drain as shown in Figure 2 to improve the condensate drainage. On small units (less than 2.5 tons/8.8 kW), insure that unit pitch does not cause condensate leaks inside the cabinet.

The horizontal run of a condensate hose is usually too short to cause drainage problems. However, the horizontal run of the condensate line should be pitched at least 1 inch for every 10 feet [10mm per 116cm] of run in the direction of flow to insure that the connection will not slip off due to excessive weight or piping expansion/contraction. Avoid low points and non-pitched piping since dirt collects in low or level areas and may cause stoppage and overflow.

Install condensate trap at each unit with the top of the trap positioned below the unit condensate drain connection as shown in Figure 6. Design the depth of the trap (water-seal) based upon the amount of ESP capability of the blower (where 2 inches [51mm] of ESP capability requires 2 inches [51mm] of trap depth). As a general rule, 1-1/2 inch [38mm] trap depth is the minimum.

Each unit must be installed with its own individual trap and connection to the condensate line (main) or riser. Provide a means to flush or blow out the condensate line. DO NOT install units with a common trap and/or vent.

Always vent the condensate line when dirt or air can collect in the line or a long horizontal drain line is required. Also vent when large units are working against higher external static pressure than other units connected to the same condensate main since this may cause poor drainage for all units on the line. WHEN A VENT IS INSTALLED IN THE DRAIN LINE, IT MUST BE LOCATED AFTER THE TRAP IN THE DIRECTION OF THE CONDENSATE FLOW.

Figure 6: Horizontal Condensate Connection

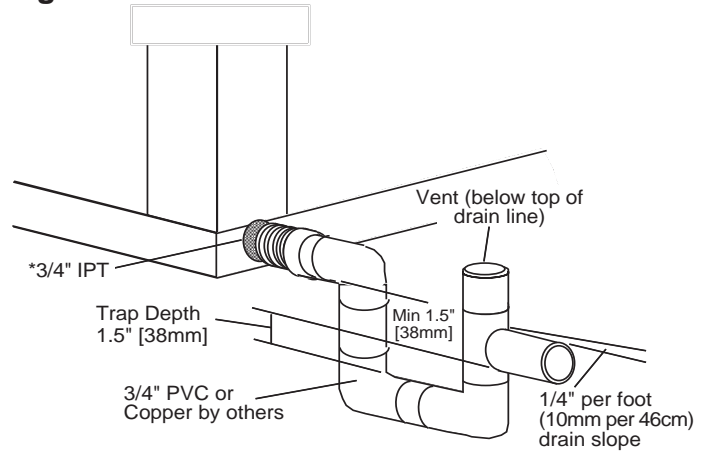

* Some units include a painted drain connection. Using a threaded pipe or similar device to clear any excess paint accumulated inside this fitting may ease final drain line installation.

Rev.: 10/26/06D

⚠ CAUTION! ⚠

CAUTION! Ensure condensate line is pitched toward drain 1/4" per foot [10mm per 46cm] of run.

DUCT SYSTEM INSTALLATION

Duct System Installation

The duct system should be sized to handle the design airflow quietly. Refer to Figure 3 for horizontal duct system details or figure 8 for vertical duct system details. A flexible connector is recommended for both discharge and return air duct connections on metal duct systems to eliminate the transfer of vibration to the duct system. To maximize sound attenuation of the unit blower, the supply and return plenums should include internal fiberglass duct liner or be constructed from ductboard for the first few feet. Application of the unit to uninsulated ductwork in an unconditioned space is not recommended, as the unit's performance will be adversely affected.

At least one 90° elbow should be included in the supply duct to reduce air noise. If air noise or excessive air flow is a problem, the blower speed can be changed. For airflow charts, consult specifications catalog for the series and model of the specific unit.

If the unit is connected to existing ductwork, a previous check should have been made to insure that the ductwork has the capacity to handle the airflow required for the unit. If ducting is too small, as in the replacement of a heating only system, larger ductwork should be installed. All existing ductwork should be checked for leaks and repaired as necessary.

VERTICAL INSTALLATION

Vertical Unit Location

Units are not designed for outdoor installation. Locate the unit in an INDOOR area that allows enough space for service personnel to perform typical maintenance or repairs without removing unit from the mechanical room/closet. Vertical units are typically installed in a mechanical room or closet. Never install units in areas subject to freezing or where humidity levels could cause cabinet condensation (such as unconditioned spaces subject to 100% outside air). Consideration should be given to access for easy removal of the filter and access panels. Provide sufficient room to make water, electrical, and duct connection(s).

If the unit is located in a confined space, such as a closet, provisions must be made for return air to freely enter the space by means of a louvered door, etc. Any access panel screws that would be difficult to remove after the unit is installed should be removed prior to setting the unit. Refer to Figures 7 and 8 for typical installation illustrations. Refer to unit specifications catalog for dimensional data.

1. Install the unit on a piece of rubber, neoprene or other mounting pad material for sound isolation. The pad should be at least 3/8" [10mm] to 1/2" [13mm] in thickness. Extend the pad beyond all four edges of the unit.
2. Provide adequate clearance for filter replacement and drain pan cleaning. Do not block filter access with piping, conduit or other materials. Refer to unit specifications for dimensional data.
3. Provide access for fan and fan motor maintenance and for servicing the compressor and coils without removing the unit.
4. Provide an unobstructed path to the unit within the closet or mechanical room. Space should be sufficient to allow removal of the unit, if necessary.
5. In limited side access installations, pre-removal of the control box side mounting screws will allow control box removal for future servicing (R22 units only).
6. Provide access to water valves and fittings and screwdriver access to the unit side panels, discharge collar and all electrical connections.

Downflow units may be installed directly on the floor. The optional internal electric heat is rated for zero clearance to combustible materials.

The installation of water source heat pump units and all associated components, parts and accessories which make up the installation shall be in accordance with the regulations of ALL authorities having jurisdiction and MUST conform to all applicable codes. It is the responsibility of the installing contractor to determine and comply with ALL applicable codes and regulations.

Figure 7: Vertical Unit Mounting

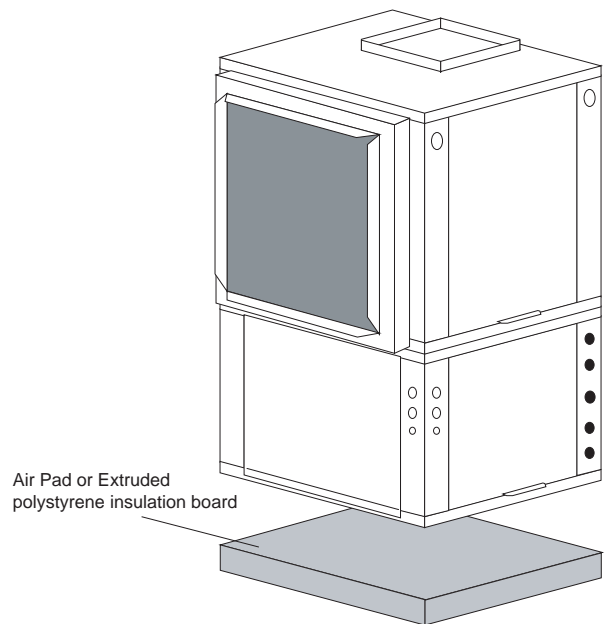
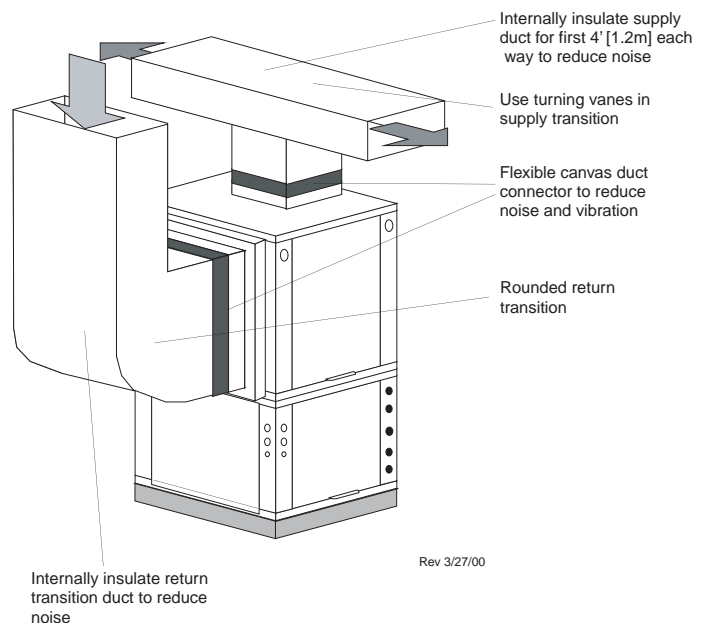

Figure 8: Typical Vertical Unit Installation Using Ducted Return Air



VERTICAL INSTALLATION

Sound Attenuation for Vertical Units

Sound attenuation is achieved by enclosing the unit within a small mechanical room or a closet. Additional measures for sound control include the following:

1. Mount the unit so that the return air inlet is 90° to the return air grille. Refer to Figure 9. Install a sound baffle as illustrated to reduce line-of-sight sound transmitted through return air grilles.
2. Mount the unit on a rubber or neoprene isolation pad to minimize vibration transmission to the building structure.

Figure 9: Vertical Sound Attenuation

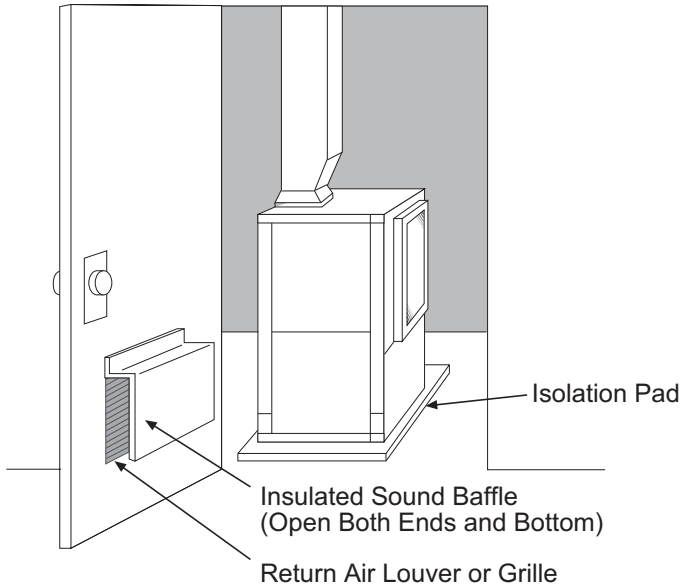

Condensate Piping – Vertical Units

Vertical units utilize a condensate hose inside the cabinet as a trapping loop; therefore an external trap is not necessary. Figure 10a shows typical condensate connections. Figure 10b illustrates the internal trap for a typical vertical heat pump. Each unit must be installed with its own individual vent (where necessary) and a means to flush or blow out the condensate drain line. Do not install units with a common trap and/or vent.

Figure 10a: Vertical Condensate Drain

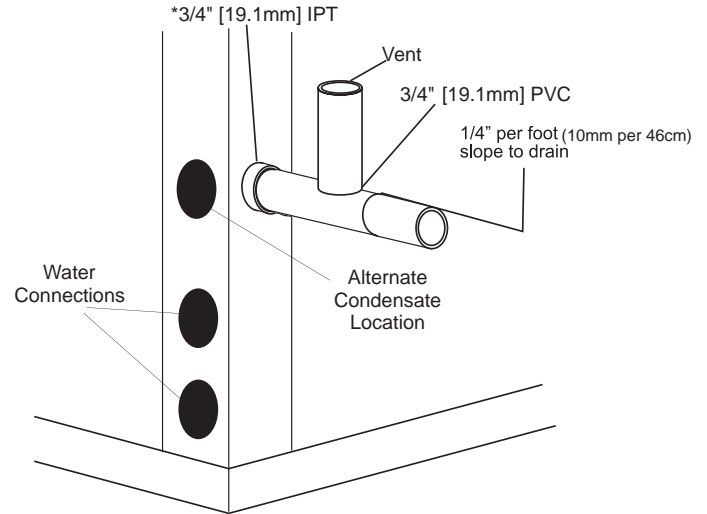

* Some units include a painted drain connection. Using a threaded pipe or similar device to clear any excess paint accumulated inside this fitting may ease final drain line installation.

Figure 10b: Vertical Internal Condensate Trap

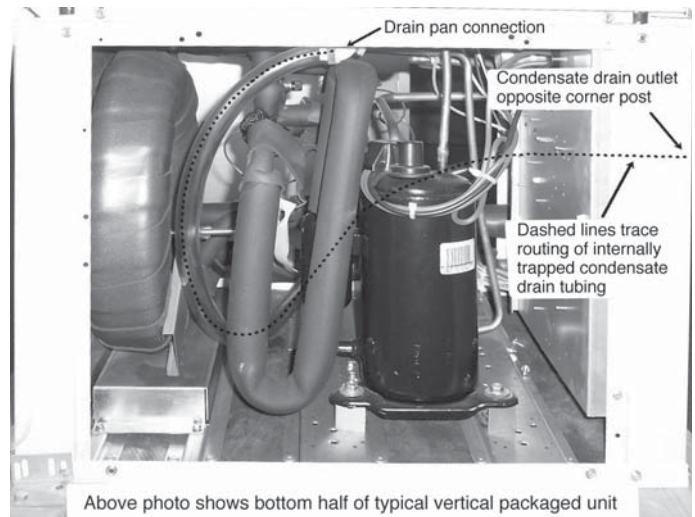

WATER CONNECTION INSTALLATION

External Flow Controller Mounting

The Flow Controller can be mounted beside the unit as shown in Figure 12. Review the Flow Controller installation manual for more details.

Water Connections-Residential (Distributor) Models

Residential models utilize swivel piping fittings for water connections that are rated for 450 psi (3101 kPa) operating pressure. The connections have a rubber gasket seal similar to a garden hose gasket, which when mated to the flush end of most 1" threaded male pipe fittings provides a leak-free seal without the need for thread sealing tape or joint compound. Insure that the rubber seal is in the swivel connector prior to attempting any connection (rubber seals are shipped attached to the swivel connector). **DO NOT OVER TIGHTEN** or leaks may occur.

The female locking ring is threaded onto the pipe threads which holds the male pipe end against the rubber gasket, and seals the joint. **HAND TIGHTEN ONLY! DO NOT OVERTIGHTEN!**

Figure 11: Water Connections

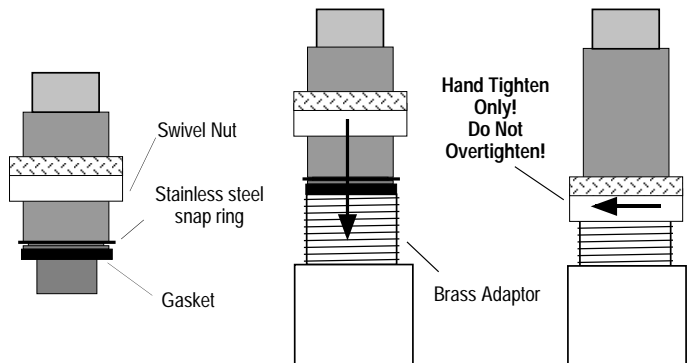

GROUND-LOOP HEAT PUMP APPLICATIONS

⚠ CAUTION! ⚠

CAUTION! The following instructions represent industry accepted installation practices for closed loop earth coupled heat pump systems. Instructions are provided to assist the contractor in installing trouble free ground loops. These instructions are recommendations only. State/provincial and local codes **MUST** be followed and installation **MUST** conform to **ALL** applicable codes. It is the responsibility of the installing contractor to determine and comply with **ALL** applicable codes and regulations.

Pre-Installation

Prior to installation, locate and mark all existing underground utilities, piping, etc. Install loops for new construction before sidewalks, patios, driveways, and other construction has begun. During construction, accurately mark all ground loop piping on the plot plan as an aid in avoiding potential future damage to the installation.

Piping Installation

The typical closed loop ground source system is shown in Figure 12. All earth loop piping materials should be limited to polyethylene fusion only for in-ground sections of the loop. Galvanized or steel fittings should not be used at any time due to their tendency to corrode. All plastic to metal threaded fittings should be avoided due to their potential to leak in earth coupled applications. A flanged fitting should be substituted. P/T plugs should be used so that flow can be measured using the pressure drop of the unit heat exchanger.

Earth loop temperatures can range between 25 and 110°F [-4 to 43°C]. Flow rates between 2.25 and 3 gpm per ton [2.41 to 3.23 l/m per kW] of cooling capacity is recommended in these applications.

Test individual horizontal loop circuits before backfilling. Test vertical U-bends and pond loop assemblies prior to installation. Pressures of at least 100 psi [689 kPa] should be used when testing. Do not exceed the pipe pressure rating. Test entire system when all loops are assembled.

Flushing the Earth Loop

Once piping is completed between the unit, Flow Controller and the ground loop (Figure 12), the loop is ready for final purging and charging. A flush cart with at least a 1.5 hp [1.1 kW] pump is required to achieve enough fluid velocity in the loop piping system to purge air and dirt particles. An antifreeze solution is used in most areas to prevent freezing. All air and debris must be removed from the earth loop piping before operation. Flush the loop with a high volume of water at a minimum velocity of 2 fps (0.6 m/s) in all piping. The steps below must be followed for proper flushing.

1. Fill loop with water from a garden hose through the flush cart before using the flush cart pump to insure an even fill.
2. Once full, the flushing process can begin. Do not allow the water level in the flush cart tank to drop below the pump inlet line to avoid air being pumped back out to the earth loop.
3. Try to maintain a fluid level in the tank above the return tee so that air cannot be continuously mixed back into the fluid. Surges of 50 psi (345 kPa) can be used to help purge air pockets by simply shutting off the return valve going into the flush cart reservoir. This "dead heads" the pump to 50 psi (345 kPa). To purge, dead head the pump until maximum pumping

GROUND-LOOP HEAT PUMP APPLICATIONS

pressure is reached. Open the return valve and a pressure surge will be sent through the loop to help purge air pockets from the piping system.

- Notice the drop in fluid level in the flush cart tank when the return valve is shut off. If air is adequately purged from the system, the level will drop only 1-2 inches (2.5 - 5 cm) in a 10" (25 cm) diameter PVC flush tank (about a half gallon [2.3 liters]), since liquids are incompressible. If the level drops more than this, flushing should continue since air is still being compressed in the loop fluid. Perform the "dead head" procedure a number of times.

Note: This fluid level drop is your only indication of air in the loop.

Antifreeze may be added before, during or after the flushing procedure. However, depending upon which time is chosen, antifreeze could be wasted when emptying the flush cart tank. See antifreeze section for more details.

Loop static pressure will fluctuate with the seasons. Pressures will be higher in the winter months than during the cooling season. This fluctuation is normal and should be considered when charging the system initially. Run the unit in either heating or cooling for a number of minutes to condition the loop to a homogenous temperature. This is a good time for tool cleanup, piping insulation, etc. Then, perform final flush and pressurize the loop to a static pressure of 50-75 psi [345-517 kPa] (winter) or 35-40 psi [241-276 kPa] (summer). After pressurization, be sure to loosen the plug at the end of the Grundfos loop pump motor(s) to allow trapped air to be discharged and to insure the motor housing has been flooded. This is not required for Taco circulators. Insure that the Flow Controller provides adequate flow through the unit by checking pressure drop across the heat exchanger and compare to the pressure drop tables at the back of the manual.

Antifreeze

In areas where minimum entering loop temperatures drop below 40°F [5°C] or where piping will be routed through areas subject to freezing, antifreeze is required. Alcohols and glycols are commonly used as antifreeze; however your local sales manager should be consulted for the antifreeze best suited to your area. Freeze protection

should be maintained to 15°F [9°C] below the lowest expected entering loop temperature. For example, if 30°F [-1°C] is the minimum expected entering loop temperature, the leaving loop temperature would be 25 to 22°F [-4 to -6°C] and freeze protection should be at 15°F [-10°C]. Calculation is as follows:
 $30^{\circ}\text{F} - 15^{\circ}\text{F} = 15^{\circ}\text{F}$ [$-1^{\circ}\text{C} - 9^{\circ}\text{C} = -10^{\circ}\text{C}$].

All alcohols should be premixed and pumped from a reservoir outside of the building when possible or introduced under the water level to prevent fumes. Calculate the total volume of fluid in the piping system. Then use the percentage by volume shown in Table 1 for the amount of antifreeze needed. Antifreeze concentration should be checked from a well mixed sample using a hydrometer to measure specific gravity.

Low Water Temperature Cutout Setting CXM or DXM Control

When antifreeze is selected, the FP1 jumper (JW3) should be clipped to select the low temperature (antifreeze 13°F [-10.6°C]) set point and avoid nuisance faults (see "Low Water Temperature Cutout Selection" in this manual). NOTE: Low water temperature operation requires extended range equipment.

Table 1: Approximate Fluid Volume (gal.) per 100' of Pipe

Fluid Volume (gal [liters]) per 100' [30 meters] Pipe		
Pipe	Size	Volume (gal) [liters]
Copper	1"	4.1 [15.3]
	1.25"	6.4 [23.8]
	2.5"	9.2 [34.3]
Rubber Hose	1"	3.9 [14.6]
Polyethylene	3/4" IPS SDR11	2.8 [10.4]
	1" iPS SDR11	4.5 [16.7]
	1.25" IPS SDR11	8.0 [29.8]
	1.5" IPS SDR11	10.9 [40.7]
	2" IPS SDR11	18.0 [67.0]
	1.25" IPS SCH40	8.3 [30.9]
	1.5" IPS SCH40	10.9 [40.7]
2" IPS SCH40	17.0 [63.4]	
Unit Heat Exchanger	Typical	1.0 [3.8]
Flush Cart Tank	10" Dia x 3ft tall [254mm x 91.4cm tall]	10 [37.9]

Table 2: Antifreeze Percentages by Volume

Type	Minimum Temperature for Low Temperature Protection			
	10°F [-12.2°C]	15°F [-9.4°C]	20°F [-6.7°C]	25°F [-3.9°C]
Methanol	25%	21%	16%	10%
100% USP food grade Propylene Glycol	38%	25%	22%	15%
Ethanol*	29%	25%	20%	14%

* Must not be denatured with any petroleum based product

GROUND-LOOP HEAT PUMP APPLICATIONS

Figure 12: Typical Ground-Loop Application

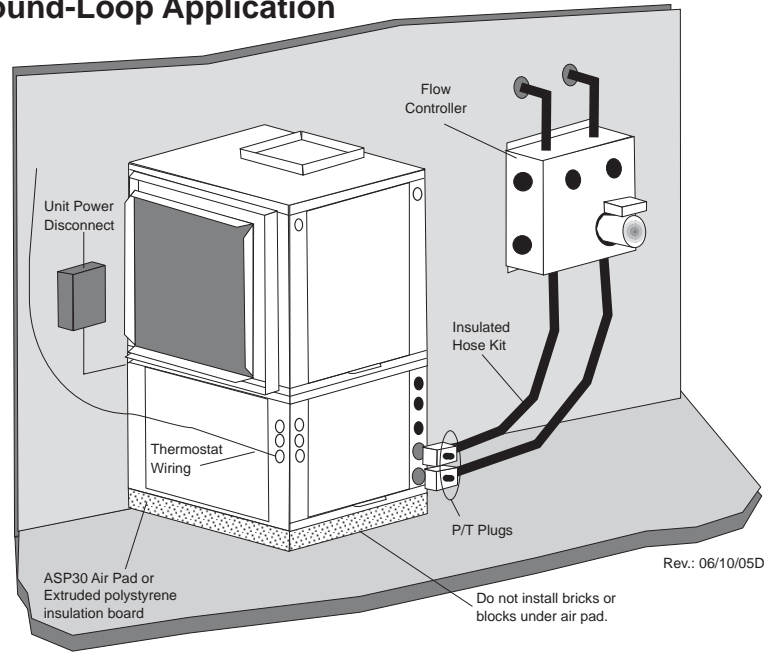

GROUND-WATER HEAT PUMP APPLICATIONS

Open Loop - Ground Water Systems

Typical open loop piping is shown in Figure 13. Shut off valves should be included for ease of servicing. Boiler drains or other valves should be "tee'd" into the lines to allow acid flushing of the heat exchanger. Shut off valves should be positioned to allow flow through the coax via the boiler drains without allowing flow into the piping system. P/T plugs should be used so that pressure drop and temperature can be measured. Piping materials should be limited to copper or PVC SCH80. Note: Due to the pressure and temperature extremes, PVC SCH40 is not recommended.

Water quantity should be plentiful and of good quality. Consult table 3 for water quality guidelines. The unit can be ordered with either a copper or cupro-nickel water heat exchanger. Consult table 3 for recommendations. Copper is recommended for closed loop systems and open loop ground water systems that are not high in mineral content or corrosiveness. In conditions anticipating heavy scale formation or in brackish water, a cupro-nickel heat exchanger is recommended. In ground water situations where scaling could be heavy or where biological growth such as iron bacteria will be present, an open loop system is not recommended. Heat exchanger coils may over time lose heat exchange capabilities due to build up of mineral deposits. Heat exchangers must only be serviced by a qualified technician, as acid and special pumping equipment is required. Desuperheater coils can likewise become scaled and possibly plugged. In areas with extremely hard water, the owner should be informed that the heat exchanger may require occasional acid flushing. In some cases, the desuperheater option should not be recommended due to hard water conditions and additional maintenance required.

Water Quality Standards

Table 3 should be consulted for water quality requirements. Scaling potential should be assessed using the pH/Calcium hardness method. If the pH <7.5 and the Calcium hardness is less than 100 ppm, scaling potential is low. If this method yields numbers out of range of those listed, the Ryznar Stability and Langelier Saturation indices should be calculated. Use the appropriate scaling surface temperature for the application, 150°F [66°C] for direct use (well water/open loop) and DHW (desuperheater); 90°F [32°F] for indirect use. A monitoring plan should be implemented in these probable scaling situations. Other water quality issues such as iron fouling, corrosion prevention and erosion and clogging should be referenced in Table 3.

Expansion Tank and Pump

Use a closed, bladder-type expansion tank to minimize mineral formation due to air exposure. The expansion tank should be sized to provide at least one minute continuous run time of the pump using its drawdown capacity rating to prevent pump short cycling. Discharge water from the unit is not contaminated in any manner and can be disposed of in various ways, depending on local building codes (e.g. recharge well, storm sewer, drain field, adjacent stream or pond, etc.). Most local codes forbid the use of sanitary sewer for disposal. Consult your local building and zoning department to assure compliance in your area.

The pump should be sized to handle the home's domestic water load (typically 5-9 gpm [23-41 l/m]) plus the flow rate required for the heat pump. Pump sizing and expansion tank must be chosen as complimentary

GROUND-WATER HEAT PUMP APPLICATIONS

items. For example, an expansion tank that is too small can cause premature pump failure due to short cycling. Variable speed pumping applications should be considered for the inherent energy savings and smaller expansion tank requirements.

Water Control Valve

Note the placement of the water control valve in figure 13. Always maintain water pressure in the heat exchanger by placing the water control valve(s) on the discharge line to prevent mineral precipitation during the off-cycle. Pilot operated slow closing valves are recommended to reduce water hammer. If water hammer persists, a mini-expansion tank can be mounted on the piping to help absorb the excess hammer shock. Insure that the total 'VA' draw of the valve can be supplied by the unit transformer. For instance, a slow closing valve can draw up to 35VA. This can overload smaller 40 or 50 VA transformers depending on the other controls in the circuit. A typical pilot operated solenoid valve draws approximately 15VA (see Figure 21). Note the special wiring diagrams for slow closing valves (Figures 23 & 25).

Flow Regulation

Flow regulation can be accomplished by two methods. One method of flow regulation involves simply adjusting the ball valve or water control valve on the discharge line. Measure the pressure drop through the unit heat exchanger, and determine flow rate from tables 8a through 8c. Since the pressure is constantly varying, two pressure gauges may be needed. Adjust the valve until the desired flow of 1.5 to 2 gpm per ton [2.0 to 2.6 l/m per kW] is achieved. A second method of flow control requires a flow control device mounted on the outlet of the water control valve. The device is typically a brass fitting with an orifice of rubber or plastic material that is designed to allow a specified flow rate. On occasion, flow control devices may produce velocity noise

that can be reduced by applying some back pressure from the ball valve located on the discharge line. Slightly closing the valve will spread the pressure drop over both devices, lessening the velocity noise. **NOTE: When EWT is below 50°F [10°C], a minimum of 2 gpm per ton (2.6 l/m per kW) is required.**

Water Coil Low Temperature Limit Setting

For all open loop systems the 30°F [-1.1°C] FP1 setting (factory setting-water) should be used to avoid freeze damage to the unit. See "Low Water Temperature Cutout Selection" in this manual for details on the low limit setting.

Figure 13: Typical Open Loop/Well Application

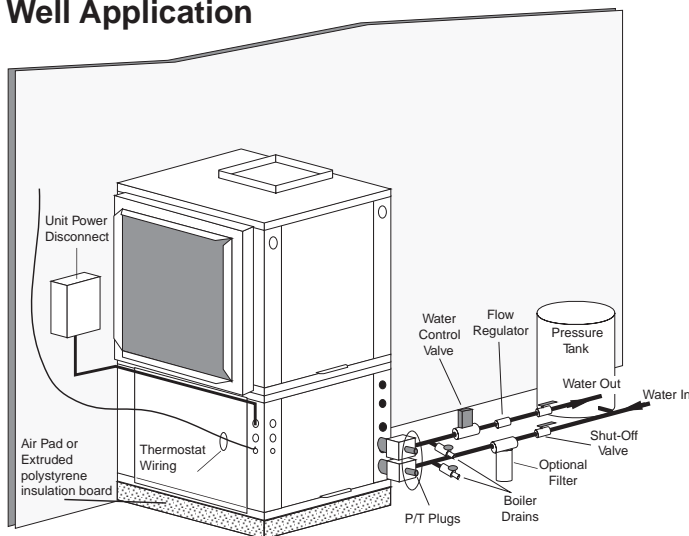

⚠ CAUTION! ⚠

CAUTION! Units with Whole House Dehumidification Modulating Reheat option installed in an open loop (well water) application require an internal bronze pump. The cupro-nickel heat exchanger option (which includes a bronze pump) must be used for these applications. Failure to select this option could result in premature equipment failure. This option is not recommended for applications with poor water quality (see water quality guidelines). The copper heat exchanger with cast iron pump (standard W.H.D. option) is designed for closed loop systems.

⚠ CAUTION! ⚠

CAUTION! Many units are installed with a factory or field supplied manual or electric shut-off valve. **DAMAGE WILL OCCUR** if shut-off valve is **closed** during unit operation. A high pressure switch must be installed on the heat pump side of any field provided shut-off valves and connected to the heat pump controls in series with the built-in refrigerant circuit high pressure switch to disable compressor operation if water pressure exceeds pressure switch setting. The field installed high pressure switch shall have a cut-out pressure of 235 psig and a cut-in pressure of 190 psig. This pressure switch can be ordered from with a 1/4" internal flare connection as part number 39B0005N01.

⚠ CAUTION! ⚠

CAUTION! Refrigerant pressure activated water regulating valves should never be used with geothermal heat pump equipment.

WATER QUALITY STANDARDS

Table 3: Water Quality Standards

Water Quality Parameter	HX Material	Closed Recirculating	Open Loop and Recirculating Well
Scaling Potential - Primary Measurement			
Above the given limits, scaling is likely to occur. Scaling indexes should be calculated using the limits below.			
pH/Calcium Hardness Method	All	-	pH < 7.5 and Ca Hardness <100ppm
Index Limits for Probable Scaling Situations - (Operation outside these limits is not recommended)			
Scaling indexes should be calculated at 150°F [66°C] for direct use and HWG applications, and at 90°F [32°C] for indirect HX use. A monitoring plan should be implemented.			
Ryznar Stability Index	All	-	6.0 - 7.5 If >7.5 minimize steel pipe use.
Langelier Saturation Index	All	-	-0.5 to +0.5 If <-0.5 minimize steel pipe use. Based upon 150°F [66°C] HWG and Direct well, 85°F [29°C] Indirect Well HX
Iron Fouling			
Iron Fe ²⁺ (Ferrous) (Bacterial Iron potential)	All	-	<0.2 ppm (Ferrous) If Fe ²⁺ (ferrous)>0.2 ppm with pH 6 - 8, O ₂ <5 ppm check for iron bacteria
Iron Fouling	All	-	<0.5 ppm of Oxygen Above this level deposition will occur.
Corrosion Prevention			
pH	All	6 - 8.5 Monitor/treat as needed	6 - 8.5 Minimize steel pipe below 7 and no open tanks with pH <8
Hydrogen Sulfide (H ₂ S)	All	-	<0.5 ppm At H ₂ S>0.2 ppm, avoid use of copper and copper nickel piping or HX's. Rotten egg smell appears at 0.5 ppm level. Copper alloy (bronze or brass) cast components are OK to <0.5 ppm.
Ammonia ion as hydroxide, chloride, nitrate and sulfate compounds	All	-	<0.5 ppm
Maximum Chloride Levels	Maximum Allowable at maximum water temperature.		
			50°F (10°C) 75°F (24°C) 100°F (38°C)
	Copper	-	<20ppm NR NR
	CuproNickel	-	<150 ppm NR NR
	304 SS	-	<400 ppm <250 ppm <150 ppm
316 SS	-	<1000 ppm <550 ppm < 375 ppm	
Titanium	-	>1000 ppm >550 ppm >375 ppm	
Erosion and Clogging			
Particulate Size and Erosion	All	<10 ppm of particles and a maximum velocity of 6 fps [1.8 m/s]. Filtered for maximum 800 micron [800mm, 20 mesh] size.	<10 ppm (<1 ppm "sandfree" for reinjection) of particles and a maximum velocity of 6 fps [1.8 m/s]. Filtered for maximum 800 micron [800mm, 20 mesh] size. Any particulate that is not removed can potentially clog components.

Rev.: 11/17/06D

Notes:

- Closed Recirculating system is identified by a closed pressurized piping system.
- Recirculating open wells should observe the open recirculating design considerations.
- NR - Application not recommended.

HOT WATER GENERATOR

The HWG (Hot Water Generator) or desuperheater option provides considerable operating cost savings by utilizing excess heat energy from the heat pump to help satisfy domestic hot water requirements. The HWG is active throughout the year, providing virtually free hot water when the heat pump operates in the cooling mode or hot water at the COP of the heat pump during operation in the heating mode. Actual HWG water heating capacities are provided in the appropriate heat pump performance data.

Heat pumps equipped with the HWG option include a built-in water to refrigerant heat exchanger that eliminates the need to tie into the heat pump refrigerant circuit in the field. The control circuit and pump are also built in for residential equipment. Figure 14 shows a typical example of HWG water piping connections on a unit with built-in pump. This piping layout minimizes scaling potential.

Electric water heaters are recommended. If a gas, propane, or oil water heater is used, a second preheat tank must be installed (Figure 15). If the electric water heater has only a single center element, the dual tank system is recommended to insure a usable entering water temperature for the HWG.

Typically a single tank of at least 52 gallons (235 liters) is used to limit installation costs and space. However, a dual tank, as shown in Figure 15, is the most efficient system,

providing the maximum storage and temperate source water to the HWG. Using a concentric or coaxial hot water tank connection fitting eliminates the need to tie into the hot water tank cold water piping, but is more susceptible to scaling. The optional concentric fitting (part # S69619804) is available from your equipment supplier and should be installed as shown in Figure 16 for applications with low scaling potential or where a water softener is used. Consult Table 3 for scaling potential tests.

It is always advisable to use water softening equipment on domestic water systems to reduce the scaling potential and lengthen equipment life. In extreme water conditions, it may be necessary to avoid the use of the HWG option since the potential cost of frequent maintenance may offset or exceed any savings.

R-410 systems inherently have a lower hot gas temperature than R-22 systems because the equipment is more efficient (i.e. less waste heat is available). It is possible that energy could be transferred from the water heater to the hot gas line instead of from the hot gas line to the water heater during certain times of the year. To prevent this from occurring, a temperature switch will deactivate the pump at those conditions that typically occur in the cooling mode with entering water temperatures of less than 50°F [10°C].

Figure 14: Typical HWG Installation

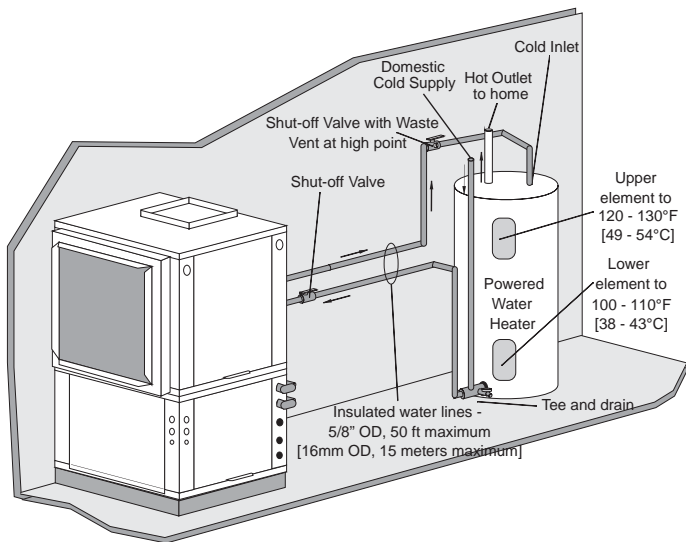
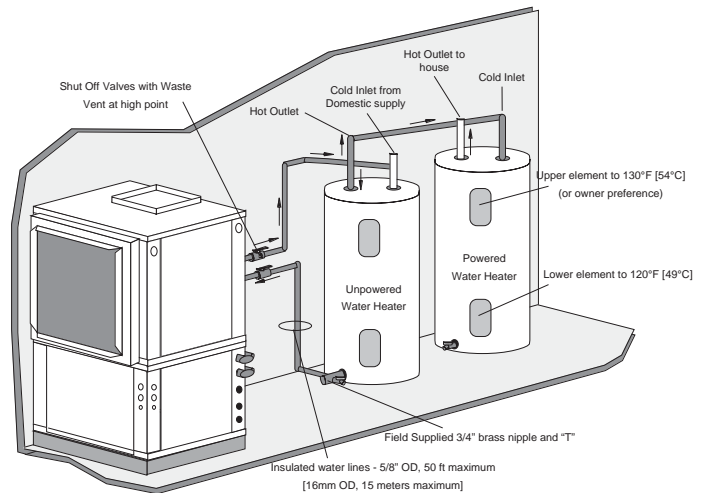
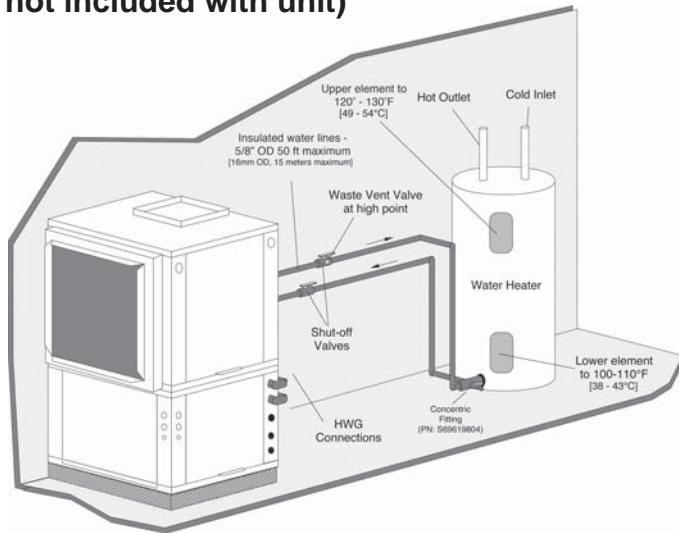

Figure 15: HWG Double Tank Installation



HOT WATER GENERATOR

Figure 16: Alternate HWG Piping with concentric/coaxial fitting (part #S69619804 not included with unit)



Installation

The HWG high limit temperature switch is set at 125°F [52°C] and is located on the HWG heat exchanger "Water In" line. If the HWG is connected incorrectly or if circulation is reversed, the aquastat will sense leaving water temperature and prevent HWG operation. **UNDER NO CIRCUMSTANCES SHOULD THE LIMIT BE DISCONNECTED OR REMOVED!** Full load conditions could drive hot water tank temperatures far above safe temperature levels if the aquastat has been disconnected or removed.

The heat pump, water piping, pump, and hot water tank should be located where the ambient temperature does not fall below 50°F [10°C]. Keep water piping lengths at a minimum. **DO NOT** use a one way length greater than 50 ft. [15 m].

All installations must be in accordance with local codes. The installer is responsible for knowing the local requirements, and for performing the installation accordingly. **DO NOT** connect the pump wiring until "Initial Start-Up" section, below. Powering the pump before all installation steps are completed may damage the pump.

Water Tank Preparation

1. Turn off power or fuel supply to the hot water tank.
2. Connect a hose to the drain valve on the water tank.
3. Shut off the cold water supply to the water tank.
4. Open the drain valve and open the pressure relief valve or a hot water faucet to drain tank.
5. When using an existing tank, it should be flushed with cold water after it is drained until the water leaving the drain hose is clear and free of sediment.
6. Close all valves and remove the drain hose.
7. Install HWG water piping.

HWG Water Piping

1. Using at least 5/8" [16mm] O.D. copper, route and install the water piping, valves and air vent as shown in Figures 14, 15, or 16. An air vent **MUST** be at the high point of the HWG water piping.
2. Insulate all HWG water piping with no less than 3/8" [10mm] wall closed cell insulation.
3. Open both shut off valves and make sure the tank drain valve is closed.

Water Tank Refill

1. Open the cold water supply to the tank.
2. Open a hot water faucet to vent air from the system until water flows from the faucet; turn off faucet.
3. Depress the hot water tank pressure relief valve handle to ensure that there is no air remaining in the tank.
4. Inspect all work for leaks.
5. Before restoring power or fuel supply to the water heater, adjust the temperature setting on the tank thermostat(s) to insure maximum utilization of the heat available from the refrigeration system and conserve the most energy. On tanks with both upper and lower elements and thermostats, the lower element should be turned down to 100°F [38°C] or the lowest setting; the upper element should be adjusted to 120-130°F [49-54°C]. Depending upon the specific needs of the customer, you may want to adjust the upper element differently. On tanks with a single thermostat, a preheat tank should be used (Figure 15).
6. Replace access cover(s) and restore power or fuel supply.

Initial Start-Up

1. Make sure all valves in the HWG water circuit are fully open.
2. Turn on the heat pump and allow it to run for 10-15 minutes.
3. Turn the heat pump and heat pump power supply "OFF" and **CONNECT POWER TO THE HWG PUMP** as shown in the unit wiring diagram. Connect the pump power lead as instructed on the tag attached to the pump wiring.
4. The HWG pump should not run if the compressor is not running.
5. The temperature difference between the water entering and leaving the HWG coil should be approximately 5-10°F [3-6°C].
6. Allow the unit to operate for 20 to 30 minutes to insure that it is functioning properly.

ELECTRICAL - LINE VOLTAGE

⚠ WARNING! ⚠

WARNING! To avoid possible injury or death due to electrical shock, open the power supply disconnect switch and secure it in an open position during installation.

⚠ CAUTION! ⚠

CAUTION! Use only copper conductors for field installed electrical wiring. Unit terminals are not designed to accept other types of conductors.

Table 4a: GT-PX (50YD) Series Electrical Data

All GT-PX Units with ECM Fan Motor							GT-PX Units (ECM) Standard					GT-PX Units (ECM) with Whole House Dehumidification					
Model	Compressor			HWG Pump FLA	Ext Loop Pump FLA	Fan Motor FLA	Total Unit FLA	Min Circuit Amps	Max Fuse/HACR	Supply Wire		W.H.D. Pump FLA	Total Unit FLA	Min Circuit Amps	Max/Fuse HACR	Supply Wire	
	RLA	LRA	Qty							Min AWG	Max Ft (m)					Min AWG	Max Ft (m)
026	10.3	52.0	1	0.40	4.0	4.3	19.0	21.6	30	10	86 (26.2)	0.8	19.8	22.4	30	10	82 (25.2)
038	16.7	82.0	1	0.40	4.0	4.3	25.4	29.6	45	10	63 (19.1)	0.8	26.2	30.4	45	8	97 (29.6)
049	21.2	96.0	1	0.40	4.0	7.0	32.6	37.9	50	8	78 (23.8)	1.07	33.7	39.0	60	8	76 (23.1)
064	25.6	118.0	1	0.40	4.0	7.0	37.0	43.4	60	6	108 (32.9)	1.07	38.1	44.5	70	6	105 (32.1)
072	27.2	150.0	1	0.40	4.0	7.0	38.6	45.4	70	60	103 (31.4)	1.07	39.6	46.4	70	6	101 (30.8)

Rated Voltage of 208-230/60/1

HACR circuit breaker in USA only

Wire length based on one way measurement with 2% voltage drop

Min/Max Voltage of 197/254

All fuses Class RK-5

Wire size based on 60°C copper conductor and Minimum Circuit Ampacity.

Table 4b: GT-PG (50YE) Series Electrical Data

Standard GT-PG Unit											GT-PG Unit with Whole House Dehumidification						
Model	Compressor			HWG Pump FLA	Ext Loop Pump FLA	Fan Motor FLA	Total Unit FLA	Min Circuit Amps	Max Fuse/HACR	Supply Wire		W.H.D. Pump FLA	Total Unit FLA	Min Circuit Amps	Max/Fuse HACR	Supply Wire	
	RLA	LRA	Qty							Min AWG	Max Ft (m)					Min AWG	Max Ft (m)
PSC Electrical Data																	
018	6.8	38.0	1	0.40	4.0	1.0	12.2	13.9	20	12	83 (25.5)	0.8	13.0	14.7	20	12	79 (24.1)
024	12.8	60.0	1	0.40	4.0	1.1	18.3	21.5	30	10	86 (26.3)	0.8	19.1	22.3	35	10	83 (25.4)
030	13.5	61.0	1	0.40	4.0	1.4	19.3	22.7	35	10	81 (24.9)	0.8	20.1	23.5	35	10	78 (24.1)
036	14.7	72.5	1	0.40	4.0	2.1	21.2	24.9	35	10	74 (22.7)	0.8	22.0	25.7	40	10	72 (22.0)
042	15.4	83.0	1	0.40	4.0	2.1	21.9	25.8	40	10	72 (21.9)	0.8	22.7	26.6	40	10	70 (21.3)
048	20.5	109.0	1	0.40	4.0	3.0	27.9	33.0	50	8	90 (27.3)	1.07	29.0	34.1	50	8	87 (26.4)
060	26.9	145.0	1	0.40	4.0	4.9	36.2	42.9	60	6	109 (33.3)	1.07	37.3	44.0	70	6	106 (32.4)
070	30.1	158.0	1	0.40	4.0	5.8	40.3	47.8	70	6	98 (29.9)	1.07	41.4	48.9	70	6	96 (29.2)
ECM Electrical Data																	
018	6.8	38.0	1	0.40	4.0	4.3	15.5	17.2	20	12	67 (20.6)	0.8	16.3	18.0	20	12	64 (19.7)
024	12.8	60.0	1	0.40	4.0	4.3	21.5	24.7	35	10	75 (22.9)	0.8	22.3	25.5	35	10	72 (22.2)
030	13.5	61.0	1	0.40	4.0	4.3	22.2	25.6	35	10	72 (22.1)	0.8	23.0	26.4	35	10	70 (21.4)
036	14.7	72.5	1	0.40	4.0	4.3	23.4	27.1	40	10	69 (20.9)	0.8	24.2	27.9	40	10	66 (20.3)
042	15.4	83.0	1	0.40	4.0	4.3	24.1	27.9	40	10	66 (20.2)	0.8	24.9	28.8	40	10	64 (19.6)
048	20.5	109.0	1	0.40	4.0	7.0	31.9	37.0	50	8	80 (24.5)	1.07	33.0	38.1	50	8	78 (23.7)
060	26.9	145.0	1	0.40	4.0	7.0	38.3	45.0	70	6	104 (31.7)	1.07	39.4	46.1	70	6	101 (31.9)
070	30.1	158.0	1	0.40	4.0	7.0	41.5	49.0	70	6	96 (29.1)	1.07	42.6	50.1	80	6	93 (28.5)

Rated Voltage of 208-230/60/1

HACR circuit breaker in USA only

Wire length based on one way measurement with 2% voltage drop

Min/Max Voltage of 197/254

All fuses Class RK-5

Wire size based on 60°C copper conductor and Minimum Circuit Ampacity.

ELECTRICAL - LINE VOLTAGE

Table 4c: GT-G Packaged (50YC) Series Electrical Data

Model	Compressor			HWG Pump FLA	Ext Loop Pump FLA	Fan Motor FLA	Total Unit FLA	Min Circuit Amps	Max Fuse/HACR	Min AWG	Max Ft (m)
	RLA	LRA	Qty								
PSC Electrical Data											
015	6.1	29.0	1	0.4	4.0	1.0	11.5	13.0	15	12	56 (17.2)
018	7.7	38.0	1	0.4	4.0	1.0	13.1	15.0	20	12	77 (23.6)
024	10.3	56.0	1	0.4	4.0	1.1	15.8	18.4	25	10	100 (30.7)
030	12.2	67.0	1	0.4	4.0	1.3	17.9	21.0	30	10	88 (26.9)
036	13.5	73.0	1	0.4	4.0	1.8	19.7	23.1	35	10	80 (24.5)
042	16.5	95.0	1	0.4	4.0	1.9	22.8	26.9	40	10	69 (21.0)
048	18.3	109.0	1	0.4	4.0	3.0	25.7	30.3	45	8	97 (29.7)
060	25.0	148.0	1	0.4	4.0	3.4	32.8	39.1	60	8	75 (23.0)
070	28.8	148.0	1	0.4	4.0	4.9	38.1	45.3	70	6	103 (31.5)
ECM Electrical Data											
015	6.1	29.0	1	0.4	4.0	5.0	15.5	17.0	20	12	68 (20.8)
018	7.7	38.0	1	0.4	4.0	5.0	17.1	19.0	25	12	97 (29.8)
024	10.3	56.0	1	0.4	4.0	5.0	19.7	22.3	30	10	83 (25.4)
030	12.2	67.0	1	0.4	4.0	5.0	21.6	24.7	35	10	75 (22.9)
036	13.5	73.0	1	0.4	4.0	5.0	22.9	26.3	35	10	70 (21.5)
042	16.5	95.0	1	0.4	4.0	5.0	25.9	30.0	45	10	61 (18.8)
048	18.3	109.0	1	0.4	4.0	7.4	30.1	34.7	50	8	85 (26.0)
060	25.0	148.0	1	0.4	4.0	7.4	36.8	43.1	60	6	108 (33.1)
070	28.8	148.0	1	0.4	4.0	7.4	40.6	47.8	70	6	98 (29.9)

Rated Voltage of 208/230/60/1
HACR circuit breaker in USA only

Wire length based on one way measurement with 2% voltage drop

Min/Max Voltage of 197/254

All fuses Class RK-5

Wire size based on 60°C copper conductor and Minimum Circuit Ampacity.

ELECTRICAL - POWER WIRING

⚠ WARNING! ⚠

WARNING! Disconnect electrical power source to prevent injury or death from electrical shock.

⚠ CAUTION! ⚠

CAUTION! Use only copper conductors for field installed electrical wiring. Unit terminals are not designed to accept other types of conductors.

Electrical - Line Voltage

All field installed wiring, including electrical ground, must comply with the National Electrical Code as well as all applicable local codes. Refer to the unit electrical data for fuse sizes. Consult wiring diagram for field connections that must be made by the installing (or electrical) contractor.

All final electrical connections must be made with a length of flexible conduit to minimize vibration and sound transmission to the building.

General Line Voltage Wiring

Be sure the available power is the same voltage and phase shown on the unit serial plate. Line and low voltage wiring must be done in accordance with local codes or the National Electric Code, whichever is applicable.

ELECTRICAL - POWER WIRING

Power Connection

Line voltage connection is made by connecting the incoming line voltage wires to the “L” side of the contactor as shown in Figures 17 and 18. Consult Tables 4a through 4c for correct fuse size.

208 Volt Operation

All residential 208-230 Volt units are factory wired for 230 Volt operation. The transformer may be switched to the 208V tap as illustrated on the wiring diagram by switching the red (208V) and the orange (230V) wires at the contactor terminal.

Figure 17: GT-PX/GT-PG Single Phase Line Voltage Field Wiring

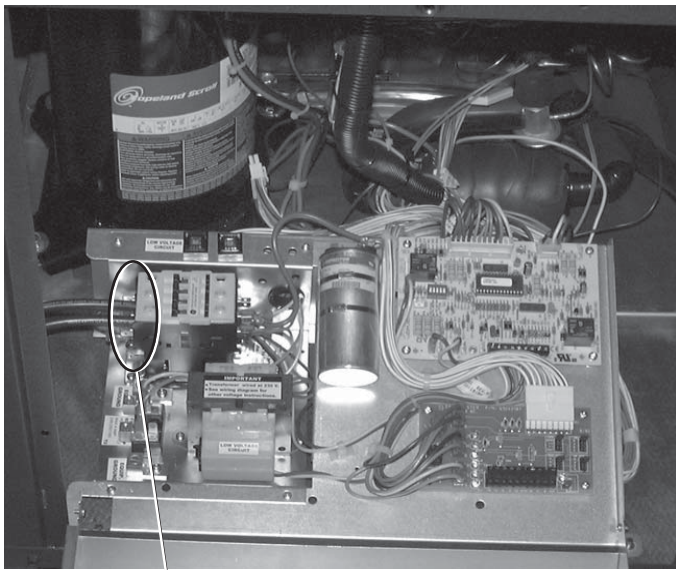

Unit Power Supply
(see electrical table for
wire and breaker size)

Blower Speed Selection – Units with PSC Motor

PSC (Permanent Split Capacitor) blower fan speed can be changed by moving the blue wire on the fan motor terminal block to the desired speed as shown in Figure 19. Optional ECM motor speeds are set via low voltage controls (see “ECM Blower Control”). Most units are shipped on the medium speed tap. Consult specifications catalog for specific unit airflow tables. Typical unit design delivers rated airflow at nominal static (0.15 in. w.g. [37Pa]) on medium speed and rated airflow at a higher static (0.4 to 0.5 in. w.g. [100 to 125 Pa]) on high speed for applications where higher static is required. Low speed will deliver approximately 85% of rated airflow at 0.10 in. w.g. [25 Pa].

Special Note for ARI Testing: To achieve rated airflow for ARI testing purposes on all PSC products, it is necessary

Figure 18: GT-G Single Phase Line Voltage Field Wiring

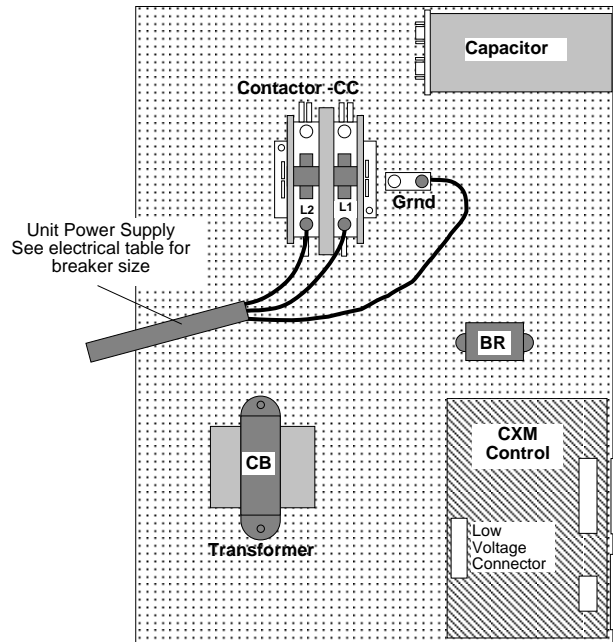

Rev.: 5/17/01 B

to change the fan speed to “HI” speed. When the heat pump has experienced less than 100 operational hours and the coil has not had sufficient time to be “seasoned”, it is necessary to clean the coil with a mild surfactant such as Calgon to remove the oils left by manufacturing processes and enable the condensate to properly “sheet” off of the coil.

Figure 19: PSC Motor Speed Selection

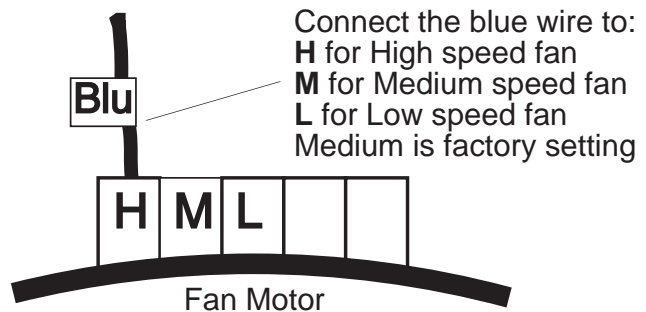

HWG Wiring

The hot water generator pump power wiring is disabled at the factory to prevent operating the HWG pump “dry.” After all HWG piping is completed and air purged from the water piping, the pump power wires should be applied to terminals on the HWG power block PB2 as shown in the unit wiring diagram. This connection can also serve as a HWG disable when servicing the unit.

ELECTRICAL - LOW VOLTAGE WIRING

Thermostat Connections

The thermostat should be wired directly to the CXM board (units with PSC fan). Units with optional ECM motor include factory wiring from the CXM board to the ECM interface board. Thermostat wiring for these units should be connected to the ECM interface board. Figure 21 shows wiring for 50YC units; Figure 20 should be used for 50YD/50YE units with PSC or optional ECM motor. See "Electrical – Thermostat" for specific terminal connections.

Figure 20: GT-PX/GT-PG Low Voltage Field Wiring

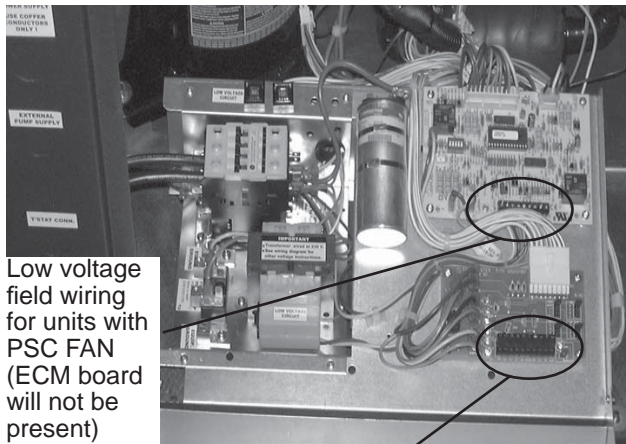

Low voltage field wiring for units with ECM fan

Figure 21: GT-G Low Voltage Field Wiring

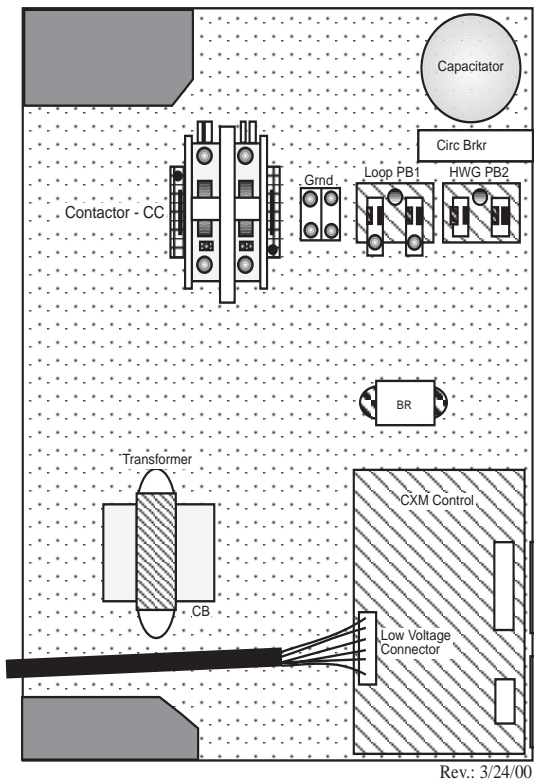

Low Water Temperature Cutout Selection

The CXM control allows the field selection of low water (or water-antifreeze solution) temperature limit by clipping jumper JW3, which changes the sensing temperature associated with thermistor FP1. Note that the FP1 thermistor is located on the refrigerant line between the coaxial heat exchanger and expansion device (TXV). Therefore, FP1 is sensing refrigerant temperature, not water temperature, which is a better indication of how water flow rate/temperature is affecting the refrigeration circuit.

The factory setting for FP1 is for systems using water (30°F [-1.1°C] refrigerant temperature). In low water temperature (extended range) applications with antifreeze (most ground loops), jumper JW3 should be clipped as shown in Figure 22 to change the setting to 10°F [-12.2°C] refrigerant temperature, a more suitable temperature when using an antifreeze solution. All residential units include water/refrigerant circuit insulation to prevent internal condensation, which is required when operating with entering water temperatures below 59°F [15°C].

Figure 22: FP1 Limit Setting

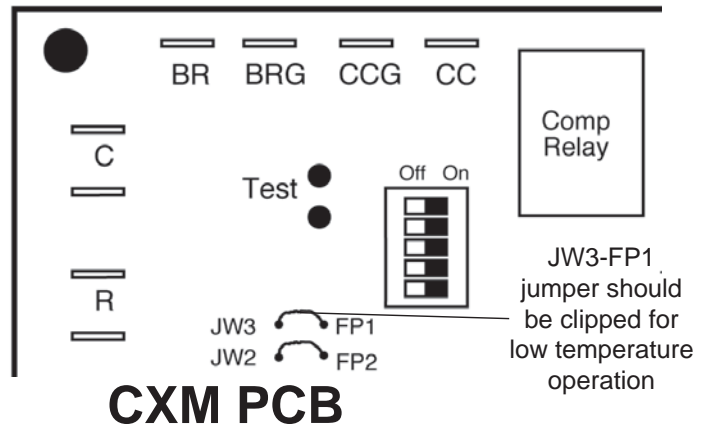

ELECTRICAL - LOW VOLTAGE WIRING

Accessory Connections

A terminal paralleling the compressor contactor coil has been provided on the CXM control. Terminal "A" is designed to control accessory devices, such as water valves. Note: This terminal should be used only with 24 Volt signals and not line voltage. Terminal "A" is energized with the compressor contactor. See Figure 23 or the specific unit wiring diagram for details.

Figure 23: Accessory Wiring

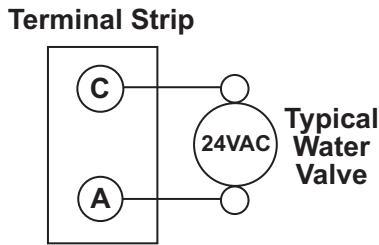

Water Solenoid Valves

An external solenoid valve(s) should be used on ground water installations to shut off flow to the unit when the compressor is not operating. A slow closing valve may be required to help reduce water hammer. Figure 23 shows typical wiring for a 24VAC external solenoid valve. Figures 24 and 25 illustrate typical slow closing water control valve wiring for Taco 500 series (ClimateMaster P/N AVM...) and Taco ESP series valves. Slow closing valves take approximately 60 seconds to open (very little water will flow before 45 seconds). Once fully open, an end switch allows the compressor to be energized. Only relay or triac based electronic thermostats should be used with slow closing valves. When wired as shown, the slow closing valve will operate properly with the following notations:

1. The valve will remain open during a unit lockout.
2. The valve will draw approximately 25-35 VA through the "Y" signal of the thermostat.

Note: This valve can overheat the anticipator of an electromechanical thermostat. Therefore, only relay or triac based thermostats should be used.

Two-stage Units

Two-stage units should be designed with two parallel valves for ground water applications to limit water use during first stage operation. For example, at 1.5 gpm/ton [2.0 l/m per kW], a 50YD049 unit requires 6 gpm [23 l/m] for full load (2nd stage) operation, but only 4 gpm [15 l/m] during 1st stage operation. Since the unit will operate on first stage 80-90% of the time, significant water savings can be realized by using two parallel solenoid valves with two flow regulators. In the example above, stage one solenoid would be installed with a 4 gpm [15 l/m] flow regulator on the outlet, while stage two would utilize a 2 gpm [8 l/m] flow regulator. When stage one is operating, the second solenoid valve will be closed. When stage two

is operating, both valves will be open, allowing full load flow rate.

Figure 26 illustrates piping for two-stage solenoid valves. Review figures 23-25 for wiring of stage one valve. Stage two valve should be wired between terminal "Y2" (ECM board) and terminal "C." NOTE: When EWT is below 50°F [10°C], a minimum of 2 gpm per ton (2.6 l/m per kW) is required.

Figure 24: AVM Valve Wiring

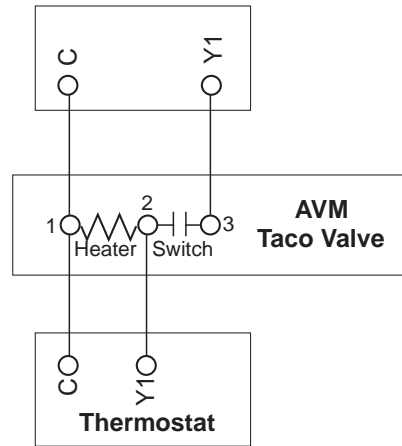

Figure 25: Taco ESP Valve Wiring

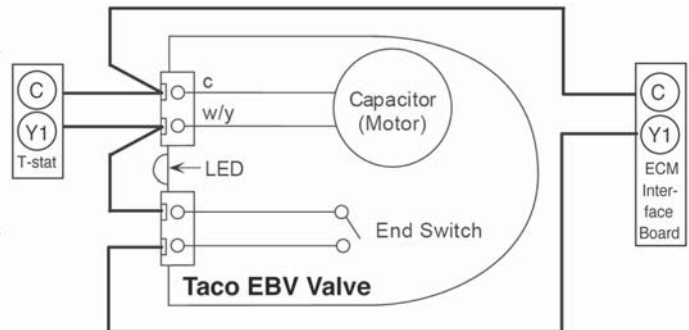
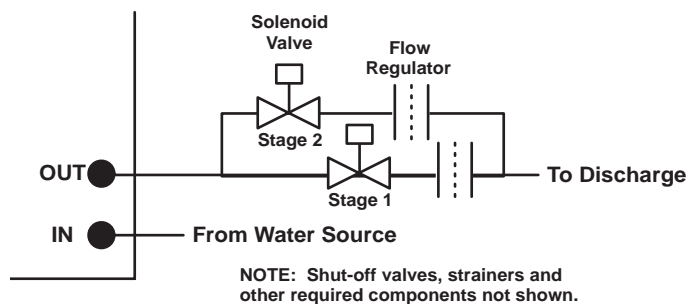

Figure 26: Two-Stage Piping



ELECTRICAL - THERMOSTAT WIRING

⚠ CAUTION! ⚠

CAUTION! Many units are installed with a factory or field supplied manual or electric shut-off valve. **DAMAGE WILL OCCUR** if shut-off valve is **closed** during unit operation. A high pressure switch must be installed on the heat pump side of any field provided shut-off valves and connected to the heat pump controls in series with the built-in refrigerant circuit high pressure switch to disable compressor operation if water pressure exceeds pressure switch setting. The field installed high pressure switch shall have a cut-out pressure of 235 psig and a cut-in pressure of 190 psig. This pressure switch can be ordered from with a 1/4" internal flare connection as part number 39B0005N01.

⚠ CAUTION! ⚠

CAUTION! Refrigerant pressure activated water regulating valves should never be used with geothermal heat pump equipment.

Thermostat Installation

The thermostat should be located on an interior wall in a larger room, away from supply duct drafts. **DO NOT** locate the thermostat in areas subject to sunlight, drafts or on external walls. The wire access hole behind the thermostat may in certain cases need to be sealed to prevent erroneous temperature measurement. Position the thermostat back plate against the wall so that it appears level and so the thermostat wires protrude through the middle of the back plate. Mark the position of the back plate mounting holes and drill holes with a 3/16" (5mm) bit. Install supplied anchors and secure plate to the wall. Thermostat wire must be 18 AWG wire. Wire the appropriate thermostat as shown in Figures 27 and 28 to the low voltage terminal strip on the CXM (units with PSC motor) or ECM control board (units with ECM motor). Practically any heat pump thermostat will work with these units, provided it has the correct number of heating and cooling stages.

NOTICE: Units with Whole House Dehumidification option require a separate humidistat (See AOM for more details).

ELECTRICAL - THERMOSTAT WIRING

**Figure 27: Thermidistat
(Carrier TSTATCCPRH01)
(Bryant TSTATBBPRH01)**

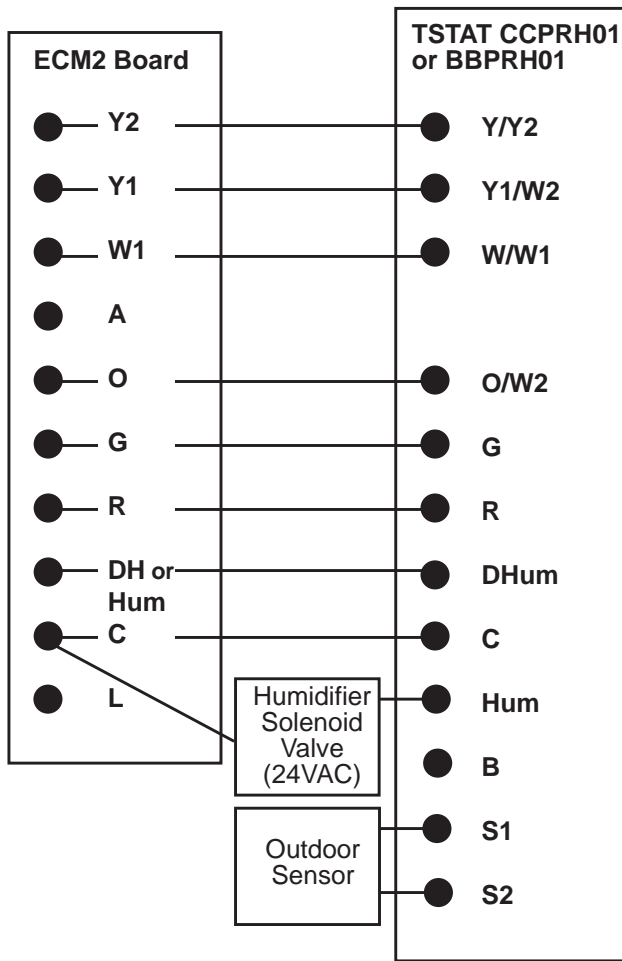

Note:

1. Thermostat DIP switches must be configured for heat pump.
2. Thermostat control configuration options must be set-up to activate "G" call when there is a "W" call in order for electric heat to operate correctly.
3. ECM board is not installed in units with PSC fan motor. Connect T-Stat directly to the CXM board for units with PSC fan.
4. Thermostat should be configured for two-stage operation for units with ECM fan motor to take advantage of the ECM features.

**Figure 28: Non-Programmable Thermostat
(Carrier TSTATCCN2S01)
(Bryant TSTATBBN2S01)**

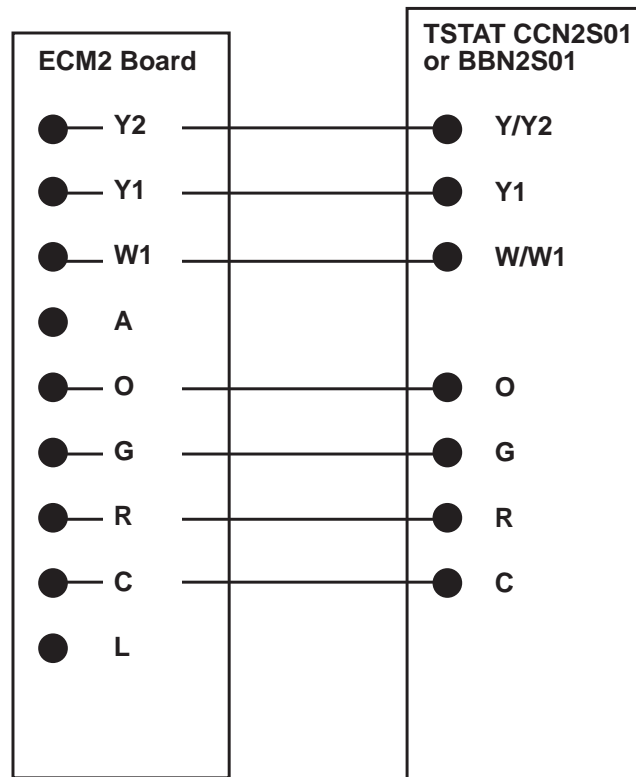

Rev.: 07/18/05D

Note:

1. Thermostat DIP switches must be configured for heat pump.
2. Thermostat control configuration options must be set-up to activate "G" call when there is a "W" call in order for electric heat to operate correctly.
3. ECM board is not installed in units with PSC fan motor. Connect T-Stat directly to the CXM board for units with PSC fan.
4. Thermostat should be configured for two-stage operation for units with ECM fan motor to take advantage of the ECM features.

ECM BLOWER CONTROL

The ECM fan is controlled by an interface board that converts thermostat inputs and field selectable CFM settings to signals used by the ECM motor controller. Units manufactured before July 2005 have version I (P/N 69243707). Units manufactured after July 2005 have version II (P/N 17B0019N01). Fan speeds are selected with jumpers for version I or via a nine position DIP switch for version II. To take full advantage of the ECM motor features, a multi-stage thermostat should be used (2-stage heat/2-stage cool or 3-stage heat/2-stage cool).

Note: Power must be off to the unit for at least three seconds before the ECM motor will recognize a speed change. The motor will recognize a change in the CFM Adjust or dehumidification mode settings while the unit is powered.

There are four different airflow settings from lowest airflow rate (speed tap 1) to the highest airflow rate (speed tap 4). The charts below indicate settings for both versions of the ECM interface board, followed by detailed information for each setting.

Cooling settings: The cooling setting determines the cooling (normal) CFM for all units with ECM motor. Cooling (normal) setting is used when the unit is not in dehumidification mode. This setting also determines the heating CFM for GT-G (50YC) units. Tap 1 is the lowest CFM setting, while tap 4 is the highest CFM setting. To avoid air coil freeze-up, tap 1 may not be used if the dehumidification mode is selected. Consult submittal data or specifications catalog for the specific unit series and model to correlate speed tap setting to airflow in CFM.

Heating settings: The heating setting determines the heating CFM for GT-PX (50YD) and GT-PG (50YE) units. This setting is not used for GT-G (50YC) units. Tap 1 is the lowest CFM setting, while tap 4 is the highest CFM setting. Consult submittal data or specifications catalog for the specific unit series and model to correlate speed tap setting to airflow in CFM.

Auxiliary/Emergency Heat settings: The auxiliary/emergency heat setting determines the CFM when the unit is in auxiliary heat or emergency heat mode. This setting is used for residential units with internal electric heat. When auxiliary electric heat is energized (i.e. compressor and electric heat), the greater of the auxiliary/emergency or heating setting will be used. A "G" (fan) signal must be present from the thermostat for electric heat to operate. Consult the submittal data or specifications catalog for the specific unit series and model to correlate speed tap setting to airflow in CFM.

CFM Adjust settings: The CFM adjust setting allows four selections. The NORM setting is the factory default position. The + or – settings adjust the airflow by +/- 15%. The +/- settings are used to "fine tune" airflow adjustments. The TEST setting runs the ECM motor at 70% torque, which causes the motor to operate like a standard PSC motor, and disables the CFM counter.

Dehumidification Mode settings: The dehumidification mode setting provides field selection of humidity control. When operating in the normal mode, the cooling airflow settings are determined by the cooling tap setting above. When dehumidification is enabled there is a reduction in airflow in cooling to increase the moisture removal of the heat pump. Consult submittal data or specifications catalog for the specific unit series and model to correlate speed tap to airflow in CFM. The dehumidification mode can be enabled in two ways.

1. **Constant Dehumidification Mode:** When the dehumidification mode is selected (via DIP switch or jumper setting), the ECM motor will operate with a multiplier applied to the cooling CFM settings (approx. 20-25% lower airflow). Any time the unit is running in the cooling mode, it will operate at the lower airflow to improve latent capacity. The "DEHUM" LED will be illuminated at all times. Heating airflow is not affected. NOTE: Do not select dehumidification mode if cooling setting is tap 1.
2. **Automatic (Humidistat-controlled) Dehumidification Mode:** When the dehumidification mode is selected (via DIP switch or jumper setting) AND a humidistat is connected to terminal DH (version II) or HUM (version I), the cooling airflow will only be reduced when the humidistat senses that additional dehumidification is required. The DH (or HUM) terminal is reverse logic. Therefore, a humidistat (not dehumidistat) is required. The "DEHUM" LED will be illuminated only when the humidistat is calling for dehumidification mode. Heating airflow is not affected. NOTE: Do not select dehumidification mode if cooling setting is tap 1.

ECM BLOWER CONTROL

Table 5: ECM Board Tap Settings

Cooling settings: All units*

Tap Setting	Version I 69243707	Version II 17B0019N01	
	HP CFM Jumper	DIP Switch	
		SW1	SW2
1	1	ON	ON
2	2	ON	OFF
3	3	OFF	ON
4	4	OFF	OFF

*GT-G units use the same settings for both cooling (normal) CFM and heating CFM.

Heating settings: GT-PX, GT-PG units*

Tap Setting	Version I 69243707	Version II 17B0019N01	
	DELAY Jumper	DIP Switch	
		SW3	SW4
1	1	ON	ON
2	2	ON	OFF
3	3	OFF	ON
4	4	OFF	OFF

*This table not used for GT-G units.

Aux/Emerg Heat settings: All Units

Tap Setting	Version I 69243707	Version II 17B0019N01	
	AUX CFM Jumper	DIP Switch	
		SW5	SW6
1	1	ON	ON
2	2	ON	OFF
3	3	OFF	ON
4	4	OFF	OFF

*Residential units

CFM Adjust settings: All units

Tap Setting	Version I 69243707	Version II 17B0019N01	
	CFM Adj Jumper	DIP Switch	
		SW7	SW8
TEST	1	ON	ON
-	2	ON	OFF
+	3	OFF	ON
NORM	4	OFF	OFF

Dehum Mode settings: All units

Tap Setting	Version I 69243707	Version II 17B0019N01
	Dehumid Jumper	DIP Switch
		SW9
NORM	pins 1,2	ON
Dehumid	pins 2,3	OFF

Figure 29a: ECM Version II Interface Layout

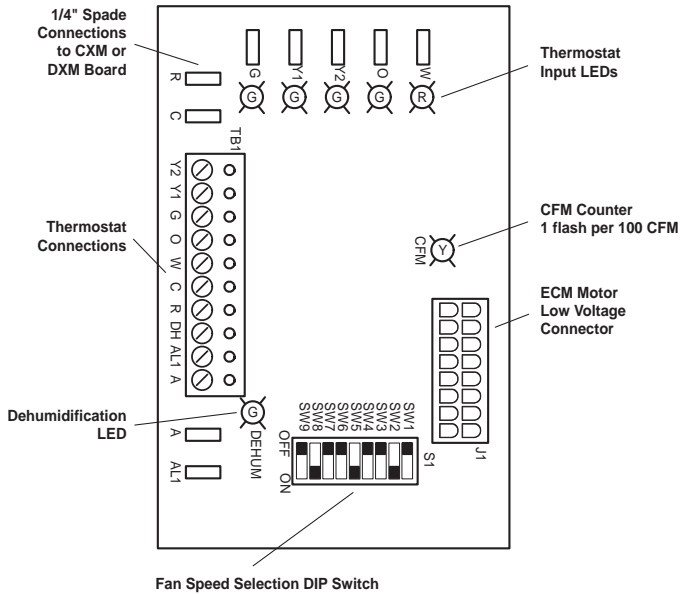
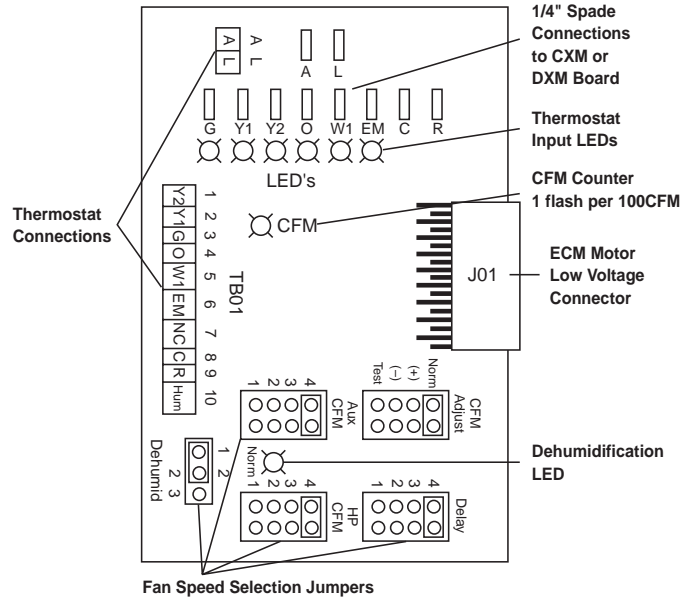

Figure 29b: ECM Version I Interface Layout



GT-PX (50YD) SERIES ECM BLOWER PERFORMANCE DATA

Airflow in CFM with wet coil and clean air filter													Residential Units Only	
Model	Max ESP (in. wg)	Fan Motor (hp)	Tap Setting	Cooling Mode			Dehumid Mode			Heating Mode			AUX CFM	Aux/ Emerg Mode
				Stg 1	Stg 2	Fan	Stg 1	Stg 2	Fan	Stg 1	Stg 2	Fan		
026	0.50	1/2	4	810	950	475	630	740	475	920	1060	475	4	1060
	0.50	1/2	3	725	850	425	560	660	425	825	950	425	3	950
	0.50	1/2	2	620	730	370	490	570	370	710	820	370	2	820
	0.50	1/2	1	520	610	300				600	690	300	1	690
038	0.50	1/2	4	1120	1400	700	870	1090	700	1120	1400	700	4	1400
	0.50	1/2	3	1000	1250	630	780	980	630	1000	1250	630	3	1350
	0.50	1/2	2	860	1080	540	670	840	540	860	1080	540	2	1350
	0.50	1/2	1	730	900	450				730	900	450	1	1350
049	0.75	1	4	1460	1730	870	1140	1350	870	1560	1850	870	4	1850
	0.75	1	3	1300	1550	780	1020	1210	780	1400	1650	780	3	1660
	0.75	1	2	1120	1330	670	870	1040	670	1200	1430	670	2	1430
	0.75	1	1	940	1120	560				1010	1200	560	1	1350
064	0.75	1	4	1670	2050	1020	1300	1600	1020	1860	2280	1020	4	2280
	0.75	1	3	1500	1825	920	1160	1430	920	1650	2050	920	3	2040
	0.75	1	2	1280	1580	790	1000	1230	790	1430	1750	790	2	1750
	0.75	1	1	1080	1320	660				1200	1470	660	1	1470
072	0.75	1	4	1620	2190	1050	1270	1650	1050	1690	2230	1050	4	2230
	0.75	1	3	1500	1950	980	1170	1520	980	1600	2100	980	3	2100
	0.75	1	2	1400	1830	910	1100	1420	910	1400	1850	910	2	1870
	0.75	1	1	1320	1700	850				1240	1620	850	1	1670

Factory shipped on Tap Setting 2
 During Auxiliary operation (residential units only) the CFM will run at the higher if the heating (delay jumper) or AUX settings
 Airflow is controlled within +/- 5% up to Max ESP shown with wet coil and standard 1" fiberglass filter
 Do not select Dehumidification mode if HP CFM is on setting 1
 All units ARI/ISO/ASHRAE 13256-1 rated HP (Cooling) Delay (Heating) CFM Setting 3

Note: See pages 35 and 36 for information on setting taps.

GT-PG (50YE) SERIES PSC BLOWER PERFORMANCE DATA

Airflow in CFM with wet coil and clean air filter																			
Model	Fan Speed	Rated Airflow	Min CFM	Airflow (cfm) at External Static Pressure (in. wg)															
				0.00	0.05	0.10	0.15	0.20	0.25	0.30	0.35	0.40	0.45	0.50	0.60	0.70	0.80	0.90	1.00
018	HI	600	450	704	708	711	702	693	692	690	683	675	658	640	598	515			
	MED	600	450	602	601	599	590	581	583	585	579	573	560	547	492				
	LOW	600	450	531	529	527	522	517	512	506	501	495	479	462					
024	HI	850	600	965	960	954	943	931	923	914	898	882	862	842	794	725	635		
	MED	850	600	841	833	825	817	809	800	790	777	763	747	731	686	623			
	LOW	850	600	723	715	707	703	698	689	680	668	656	642	627					
030	HI	950	750	1271	1250	1229	1207	1185	1164	1143	1118	1093	1061	1029	953	875	753		
	MED	950	750	1048	1037	1025	1016	1007	994	981	962	943	915	886	822				
	LOW	950	750	890	887	884	879	874	865	855	842	829	809	789					
036	HI	1250	900	1411	1407	1402	1390	1378	1370	1361	1326	1290	1248	1205	1083	942			
	MED	1250	900	1171	1164	1156	1145	1133	1113	1092	1064	1035	997	958					
	LOW	1250	900	983	967	950	943	936	936										
042	HI	1400	1050	1634	1626	1618	1606	1594	1583	1571	1539	1507	1464	1420	1265	1078			
	MED	1400	1050	1332	1323	1314	1298	1282	1263	1243	1206	1169	1115	1060					
	LOW	1400	1050	1130	1109	1088	1086	1084	1066	1048	1052	1055							
048	HI	1600	1200	1798	1781	1764	1738	1711	1688	1665	1630	1595	1555	1514	1420	1239			
	MED	1600	1200	1384	1382	1379	1375	1371	1356	1341	1318	1294	1261	1227					
	LOW	1600	1200																
060	HI	1950	1500	2311	2306	2300	2290	2279	2268	2257	2233	2209	2175	2140	2088	1990	1901	1856	1752
	MED	1950	1500	2058	2049	2039	2028	2016	2000	1983	1966	1949	1935	1920	1874	1807	1750	1670	1582
	LOW	1950	1500	1868	1863	1858	1858	1858	1848	1838	1822	1806	1799	1792	1749	1699	1636	1570	
070	HI	2100	1800	2510	2498	2486	2471	2455	2440	2424	2401	2377	2348	2318	2247	2161	2078	1986	1855
	MED	2100	1800	2171	2167	2162	2162	2162	2158	2153	2135	2117	2101	2085	2024	1971	1891	1823	
	LOW	2100	1800	2010	2008	2006	2006	2006	2006	2006	1992	1977	1962	1947	1892	1851			

Black areas denote ESP where operation is not recommended.
 Units factory shipped on medium speed. Other speeds require field selection.
 All airflow is rated and shown above at the lower voltage if unit is dual voltage rated, e.g. 208V for 208-230V units.

GT-PG (50YE) SERIES ECM BLOWER PERFORMANCE DATA

Airflow in CFM with wet coil and clean air filter

Model	Max ESP (in. wg)	Fan Motor (hp)	Tap Setting	Cooling Mode			Dehumid Mode			Heating Mode			Residential Units Only	
				Stg 1	Stg 2	Fan	Stg 1	Stg 2	Fan	Stg 1	Stg 2	Fan	AUX CFM	Aux/ Emerg Mode
018	0.50	1/2	4	620	750	380	480	590	380	620	750	380	4	750
			3	570	700	350	450	550	350	570	700	350	3	700
			2	510	620	310	400	480	310	510	620	310	2	650
			1	430	530	270				430	530	270	1	650
024	0.50	1/2	4	780	950	470	610	740	470	870	1060	470	4	1060
			3	700	850	420	540	660	420	780	950	420	3	950
			2	630	770	360	490	600	360	670	820	390	2	820
			1	550	670	300				570	690	340	1	690
030	0.50	1/2	4	920	1130	560	720	880	560	1000	1230	560	4	1230
			3	820	1000	500	640	780	500	900	1100	500	3	1100
			2	740	900	450	580	700	450	800	980	450	2	980
			1	660	800	400				700	850	400	1	850
036	0.50	1/2	4	1150	1400	700	900	1090	700	1150	1400	700	4	1400
			3	1020	1250	630	800	980	630	1020	1250	630	3	1350
			2	890	1080	540	690	840	540	890	1080	540	2	1350
			1	740	900	450				750	920	450	1	1350
042	0.50	1/2	4	1290	1580	790	1010	1230	790	1290	1580	790	4	1580
			3	1150	1400	700	900	1090	700	1150	1400	700	3	1400
			2	1050	1280	640	820	1000	640	1020	1240	640	2	1350
			1	920	1120	560				900	1080	560	1	1350
048	0.75	1	4	1420	1730	870	1110	1350	870	1520	1850	865	4	1850
			3	1270	1550	780	990	1210	780	1350	1650	775	3	1650
			2	1180	1440	720	920	1120	720	1190	1450	720	2	1450
			1	1050	1280	640				1020	1250	640	1	1350
060	0.75	1	4	1680	2050	1030	1310	1600	1030	1870	2280	1030	4	2280
			3	1500	1830	910	1170	1420	910	1680	2050	910	3	2050
			2	1400	1700	850	1090	1330	850	1480	1800	850	2	1800
			1	1300	1580	790				1270	1550	790	1	1550
070	0.75	1	4	1830	2230	1100	1420	1740	1100	1830	2230	1100	4	2230
			3	1600	1950	980	1250	1520	980	1720	2100	980	3	2100
			2	1440	1750	880	1120	1360	880	1670	1950	880	2	1950
			1	1200	1580	790				1460	1780	790	1	1780

See ECM control section for details on setting taps.

Bold numbers indicate factory settings.

During Auxiliary operation the CFM will run at the higher of the Heating (Delay jumper) or AUX settings.

Airflow is controlled within 5% up to the Max ESP shown with wet coil.

Do not select Dehumidification mode if HP CFM is on setting 1.

All units ARI/ISO/ASHRAE 13256-1 rated HP CFM Setting 3.

Note: See pages 35 and 36 for information on setting taps.

GT-G (50YC) SERIES PSC BLOWER PERFORMANCE DATA

Model	Fan Speed	Rated Airflow	MIN CFM	Airflow (cfm) at External Static Pressure (in. wg)																					
				0.00	0.05	0.10	0.15	0.20	0.25	0.30	0.35	0.40	0.45	0.50	0.60	0.70	0.80	0.90	1.00						
015	HI	500	375	880	860	840	830	820	800	780	750	730	690	660	610										
	MED	500	375	770	760	750	740	720	710	690	670	640	620	600	520										
	LOW	500	375	660	660	660	650	640	630	620	600	580	550	520	460										
018	HI	600	450	880	860	840	830	820	800	780	750	730	690	660	610										
	MED	600	450	770	760	750	740	720	710	690	670	640	620	600	520										
	LOW	600	450	660	660	660	650	640	630	620	600	580	550	520	460										
024	HI	800	600	1130	1110	1090	1060	1040	1010	980	950	920	880	840	720										
	MED	800	600	950	940	930	920	910	880	860	820	790	760	730											
	LOW	800	600	880	870	860	840	830	810	800	770	730	700	660											
030	HI	1000	750	1260	1230	1200	1180	1160	1120	1090	1050	1000	970	930	850	650									
	MED	1000	750	1180	1150	1120	1090	1070	1030	1000	970	950	910	870											
	LOW	1000	750	1040	1020	1000	980	960	930	910	870	840	820	790											
036	HI	1150	863	1400	1360	1320	1280	1250	1220	1200	1150	1110	1070	1020	940	850	690								
	MED	1150	850	1260	1240	1220	1190	1170	1130	1100	1070	1040	990	950											
	LOW	1150	863	1170	1150	1130	1100	1080	1050	1020	990	960	930	900											
042	HI	1400	1050				1670	1630	1600	1570	1540	1510	1440	1380	1290	1130	0								
	MED	1400	1050				1610	1580	1550	1510	1480	1450	1420	1390	1360	1320	1270								
	LOW	1400	1050				1270	1260	1250	1240	1220	1210	1190	1160	1120	1080	1030								
048	HI	1600	1200				2010	2000	1940	1880	1830	1780	1690	1610	1540	1310	1190								
	MED	1600	1200				1950	1910	1870	1820	1780	1740	1700	1670	1630	1570	1520				1410	1310	1170		
	LOW	1600	1200				1470	1460	1450	1440	1430	1410	1380	1360	1330	1280	1220				1110	1040			
060	HI	2000	1500				2270	2230	2200	2170	2140	2110	2040	2110	2040	1970	1870	1720	1640						
	MED	2000	1500				2260	2240	2220	2190	2170	2140	2110	2100	2080	2050	2020	1960	1870			1760	1660	1550	
	LOW	2000	1500				2050	2030	2010	1990	1970	1950	1930	1910	1880	1850	1830	1780	1700			1650	1570	1430	
070	HI	2300	1725				2460	2430	2390	2340	2310	2280	2230	2180	1990	1860	1740								
	MED	2300	1725				2530	2500	2470	2450	2420	2400	2370	2340	2310	2280	2260				2200	2100	1890	1740	1640
	LOW	2300	1725				2270	2260	2250	2240	2230	2210	2180	2160	2140	2120	2100				2040	1900	1790	1690	1570

Black areas denote ESP where operation is not recommended
 Units factory shipped on medium speed (Size 015 on low), other speeds require field selection
 All airflow is rated at lowest Voltage if unit is dual Voltage rated, e.g. 208V for 208-230V units
 All units ARI/ISO/ASHRAE 13256-1 rated on high fan speed (Size 015 rated on medium speed)

GT-G (50YC) SERIES ECM BLOWER PERFORMANCE DATA

Airflow in CFM with wet coil and clean air filter

Model	Max ESP (in. wg)	Fan Motor (hp)	Tap Setting	Normal Mode			Dehumid Mode			Residential Units Only	
				Stg 1	Stg 2	Fan	Stg 1	Stg 2	Fan	AUX CFM	Aux/ Emerg Mode
015	0.50	1/2	4	440	540	270	340	420	270	4	540
			3	410	500	250	320	390	250	3	500
			2	380	460	230	300	360	230	2	460
			1	350	430	210				1	430
018	0.50	1/2	4	530	650	320	410	510	320	4	650
			3	490	600	300	380	470	300	3	600
			2	460	560	280	360	440	280	2	560
			1	420	510	260				1	510
024	0.50	1/2	4	710	860	430	550	670	430	4	860
			3	660	800	400	510	620	400	3	800
			2	610	740	370	480	580	370	2	740
			1	560	680	340				1	680
030	0.50	1/2	4	880	1080	540	690	840	540	4	1080
			3	820	1000	500	640	780	500	3	1000
			2	760	930	460	590	730	460	2	930
			1	700	850	430				1	850
036	0.50	1/2	4	1060	1290	650	830	1010	650	4	1290
			3	980	1200	600	760	940	600	3	1200
			2	910	1110	560	710	870	560	2	1110
			1	840	1020	600				1	1020
042	0.50	1/2	4	1230	1510	750	960	1180	750	4	1510
			3	1150	1400	700	900	1090	700	3	1400
			2	1060	1300	650	830	1010	650	2	1300
			1	980	1190	600				1	1190
048	0.75	1	4	1410	1720	860	1100	1340	860	4	1720
			3	1310	1600	800	1020	1250	800	3	1600
			2	1210	1480	740	940	1150	740	2	1480
			1	1120	1360	680				1	1360
060	0.75	1	4	1760	2150	1080	1370	1680	1080	4	2150
			3	1640	2000	1000	1280	1560	1000	3	2000
			2	1520	1850	930	1190	1440	930	2	1850
			1	1390	1700	850				1	1700
070	0.75	1	4	2120	2580	1290	1650	2010	1290	4	2580
			3	1970	2400	1200	1540	1870	1200	3	2400
			2	1820	2220	1110	1420	1730	1110	2	2220
			1	1670	2040	1020				1	2040

See ECM control section for details on setting taps.

Bold numbers indicate factory settings.

During Auxiliary operation the CFM will run at the higher of the Heating (Delay jumper) or AUX settings.

Airflow is controlled within 5% up to the Max ESP shown with wet coil.

Do not select Dehumidification mode if HP CFM is on setting 1.

All units ARI/ISO/ASHRAE 13256-1 rated HP CFM Setting 3.

Note: See pages 35 and 36 for information on setting taps.

TYPICAL WIRING DIAGRAM - GT-PX/GT-PG UNITS WITH CXM BOARD AND ECM FAN MOTOR

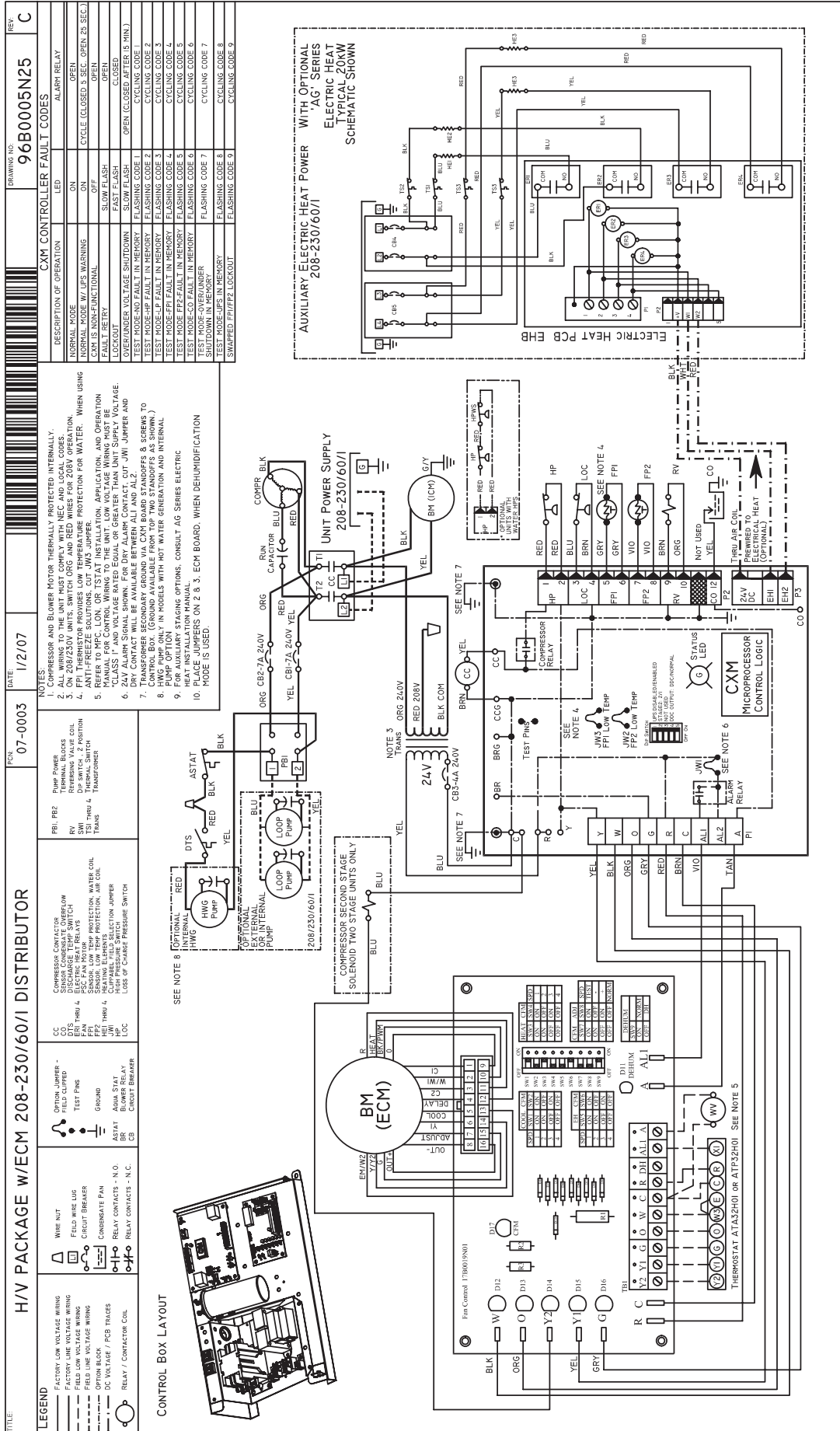

TYPICAL WIRING DIAGRAM - GT-PG UNITS WITH CXM BOARD AND PSC FAN MOTOR

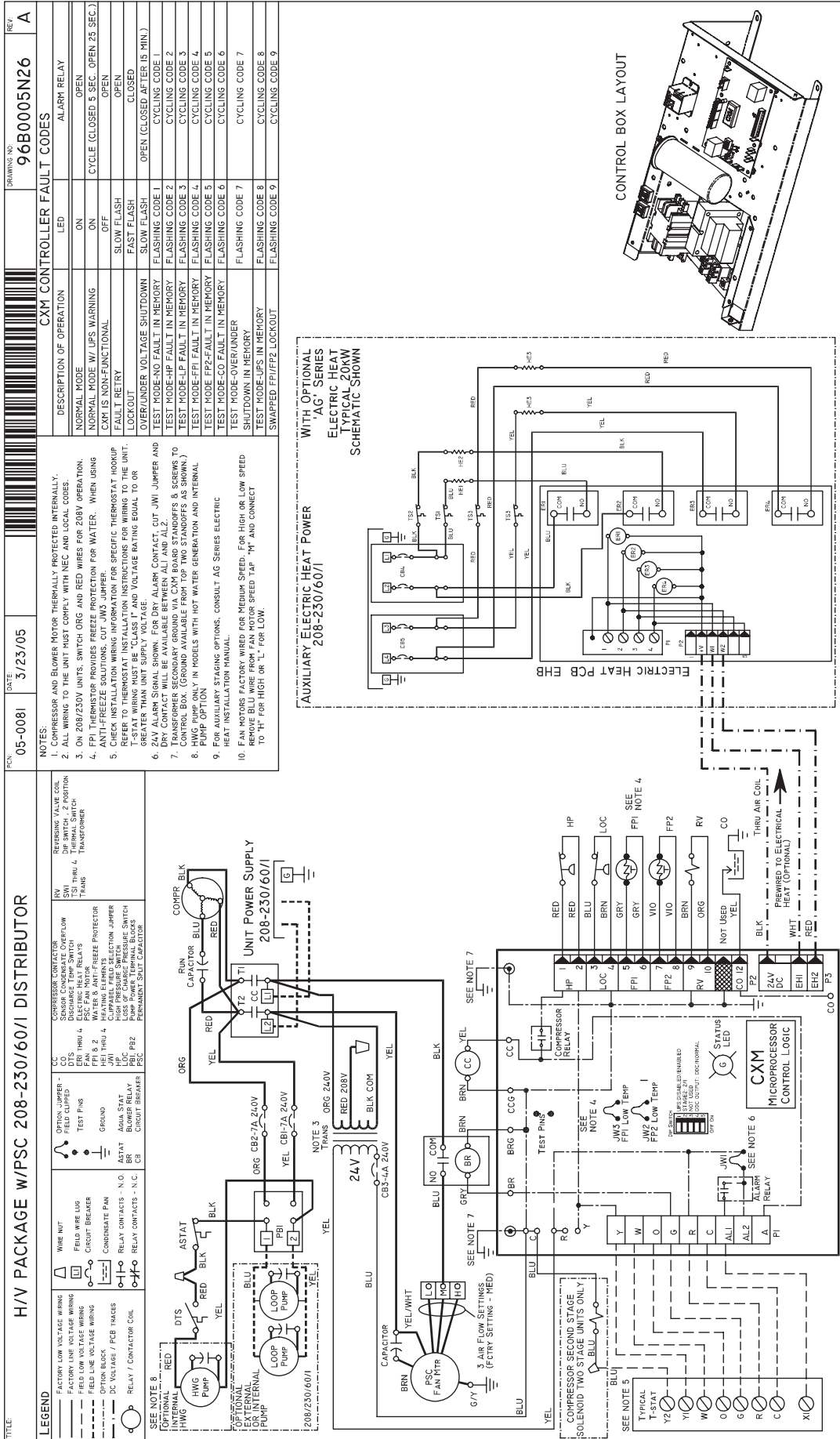

TYPICAL WIRING DIAGRAM - GT-G UNITS WITH CXM BOARD AND ECM FAN MOTOR

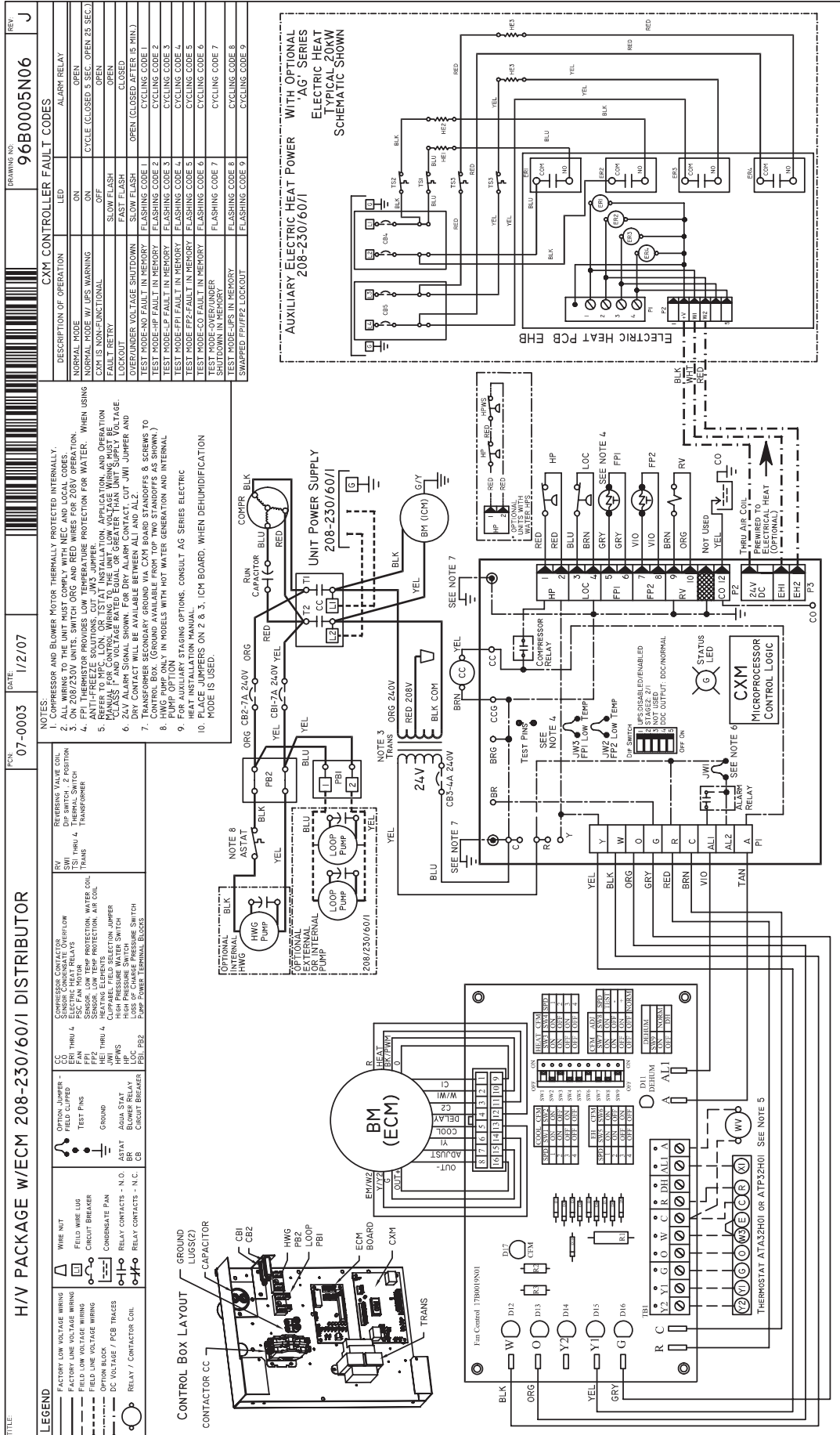

TYPICAL WIRING DIAGRAM - GT-G UNITS WITH CXM BOARD AND PSC FAN MOTOR

REV	96B0005N03	DATE	6/1/04																																																
DRAWING NO. 96B0005N03																																																			
TITLE: H/V009-070 208-230/60/1 DISTRIBUTOR PSC																																																			
<p>LEGEND</p> <p>OPTIONAL LOW VOLTAGE WIRING: FACTORY LINE VOLTAGE WIRING, FIELD LINE VOLTAGE WIRING, OPTION BLOCK, DC VOLTAGE / PCB TRACES, RELAY / CONTACTOR COIL</p> <p>OPTIONAL HIGH VOLTAGE WIRING: WIRE MIT, FIELD WIRE LUG, CIRCUIT BREAKER, CONDENSATE PAN</p> <p>OPTIONAL WIRING: OPTION JUMPER, CO, ERI THRU 4, FAN, HEI THRU 4, JWI, ANA, SW, BLOWER RELAY, CIRCUIT BREAKER, COMB. CB</p> <p>COMPRESSOR CONTACTOR: CS, CS2</p> <p>ELECTRIC HEAT RELAYS: ERS, ERS2</p> <p>PSC FAN MOTOR: PSC FAN MOTOR</p> <p>HEATING ELEMENTS: HEI THRU 4</p> <p>CLIPPABLE FIELD SELECTION JUMPER: JWS, JWS2</p> <p>LOSS OF CHARGE PRESSURE SWITCH: FP1, FP2</p> <p>PUMP POWER TERMINAL BLOCKS: T1, T2</p>																																																			
<p>NOTES:</p> <p>1. COMPRESSOR AND BLOWER MOTOR THERMALLY PROTECTED INTERNALLY.</p> <p>2. ALL WIRING TO THE UNIT MUST COMPLY WITH NEC AND LOCAL CODES.</p> <p>3. ON 208/230V UNITS, SWITCH ORG AND RED WIRES FOR 208V OPERATION.</p> <p>4. PFI THERMOSTAT PROVIDES FREEZE PROTECTION FOR WATER. WHEN USING ANTI-FREEZE SOLUTIONS, CUT JWS JUMPER.</p> <p>5. CHECK INSTALLATION WIRING INFORMATION FOR SPECIFIC THERMOSTAT HOODUP. T-STAT WIRING MUST BE "CLASS 1" AND VOLTAGE RATING EQUAL TO OR EXCEEDS UNIT VOLTAGE SHUTDOWN.</p> <p>6. 24V ALARM SIGNAL SHOWN. FOR DRY ALARM CONTACT, CUT JWI JUMPER AND DRY CONTACT WILL BE AVAILABLE BETWEEN ALL AND AL2.</p> <p>7. TRANSFORMER SECONDARY GROUND VIA CXM BOARD STANDOFFS & SCREWS TO CONTROL BOX. (GROUND AVAILABLE FROM TOP TWO STANDOFFS AS SHOWN).</p> <p>8. TEST MODE-HP FAULT IN MEMORY, TEST MODE-LF FAULT IN MEMORY, TEST MODE-PFI FAULT IN MEMORY, TEST MODE-CO FAULT IN MEMORY, HEAT INSTALLATION MANUAL.</p> <p>9. FOR AUXILIARY STAGING OPTIONS, CONSULT AG SERIES ELECTRIC HEAT INSTALLATION MANUAL.</p> <p>10. FAN MOTORS FACTORY WIRED FOR MEDIUM SPEED. FOR HIGH OR LOW SPEED REMOVE BLU WIRE FROM FAN MOTOR SPEED TAP. *H* AND CONNECT TO *H* FOR HIGH OR *L* FOR LOW.</p>																																																			
<p>CMX CONTROLLER FAULT CODES</p> <table border="1"> <thead> <tr> <th>DESCRIPTION OF OPERATION</th> <th>LED</th> <th>ALARM RELAY</th> </tr> </thead> <tbody> <tr> <td>NORMAL MODE</td> <td>ON</td> <td>OPEN</td> </tr> <tr> <td>CXM IS NON-FUNCTIONAL</td> <td>OFF</td> <td>CYCLE (CLOSED 5 SEC. OPEN 25 SEC.)</td> </tr> <tr> <td>FAULT BATTERY</td> <td>FAST FLASH</td> <td>OPEN</td> </tr> <tr> <td>LOCKOUT</td> <td>SLOW FLASH</td> <td>CLOSED</td> </tr> <tr> <td>OVER/UNDER VOLTAGE SHUTDOWN</td> <td>SLOW FLASH</td> <td>OPEN (CLOSED AFTER 15 MIN.)</td> </tr> <tr> <td>TEST MODE-NO FAULT IN MEMORY</td> <td>FLASHING CODE 1</td> <td>CYCLING CODE 1</td> </tr> <tr> <td>TEST MODE-HP FAULT IN MEMORY</td> <td>FLASHING CODE 2</td> <td>CYCLING CODE 2</td> </tr> <tr> <td>TEST MODE-LF FAULT IN MEMORY</td> <td>FLASHING CODE 3</td> <td>CYCLING CODE 3</td> </tr> <tr> <td>TEST MODE-PFI FAULT IN MEMORY</td> <td>FLASHING CODE 4</td> <td>CYCLING CODE 4</td> </tr> <tr> <td>TEST MODE-CO FAULT IN MEMORY</td> <td>FLASHING CODE 5</td> <td>CYCLING CODE 5</td> </tr> <tr> <td>TEST MODE-HP/UNDER</td> <td>FLASHING CODE 6</td> <td>CYCLING CODE 6</td> </tr> <tr> <td>TEST MODE-HP/UNDER</td> <td>FLASHING CODE 7</td> <td>CYCLING CODE 7</td> </tr> <tr> <td>TEST MODE-LPS IN MEMORY</td> <td>FLASHING CODE 8</td> <td>CYCLING CODE 8</td> </tr> <tr> <td>TEST MODE-LPS IN MEMORY</td> <td>FLASHING CODE 9</td> <td>CYCLING CODE 9</td> </tr> <tr> <td>SWAPPED PFI/FP2 LOCKOUT</td> <td>FLASHING CODE 9</td> <td>CYCLING CODE 9</td> </tr> </tbody> </table>				DESCRIPTION OF OPERATION	LED	ALARM RELAY	NORMAL MODE	ON	OPEN	CXM IS NON-FUNCTIONAL	OFF	CYCLE (CLOSED 5 SEC. OPEN 25 SEC.)	FAULT BATTERY	FAST FLASH	OPEN	LOCKOUT	SLOW FLASH	CLOSED	OVER/UNDER VOLTAGE SHUTDOWN	SLOW FLASH	OPEN (CLOSED AFTER 15 MIN.)	TEST MODE-NO FAULT IN MEMORY	FLASHING CODE 1	CYCLING CODE 1	TEST MODE-HP FAULT IN MEMORY	FLASHING CODE 2	CYCLING CODE 2	TEST MODE-LF FAULT IN MEMORY	FLASHING CODE 3	CYCLING CODE 3	TEST MODE-PFI FAULT IN MEMORY	FLASHING CODE 4	CYCLING CODE 4	TEST MODE-CO FAULT IN MEMORY	FLASHING CODE 5	CYCLING CODE 5	TEST MODE-HP/UNDER	FLASHING CODE 6	CYCLING CODE 6	TEST MODE-HP/UNDER	FLASHING CODE 7	CYCLING CODE 7	TEST MODE-LPS IN MEMORY	FLASHING CODE 8	CYCLING CODE 8	TEST MODE-LPS IN MEMORY	FLASHING CODE 9	CYCLING CODE 9	SWAPPED PFI/FP2 LOCKOUT	FLASHING CODE 9	CYCLING CODE 9
DESCRIPTION OF OPERATION	LED	ALARM RELAY																																																	
NORMAL MODE	ON	OPEN																																																	
CXM IS NON-FUNCTIONAL	OFF	CYCLE (CLOSED 5 SEC. OPEN 25 SEC.)																																																	
FAULT BATTERY	FAST FLASH	OPEN																																																	
LOCKOUT	SLOW FLASH	CLOSED																																																	
OVER/UNDER VOLTAGE SHUTDOWN	SLOW FLASH	OPEN (CLOSED AFTER 15 MIN.)																																																	
TEST MODE-NO FAULT IN MEMORY	FLASHING CODE 1	CYCLING CODE 1																																																	
TEST MODE-HP FAULT IN MEMORY	FLASHING CODE 2	CYCLING CODE 2																																																	
TEST MODE-LF FAULT IN MEMORY	FLASHING CODE 3	CYCLING CODE 3																																																	
TEST MODE-PFI FAULT IN MEMORY	FLASHING CODE 4	CYCLING CODE 4																																																	
TEST MODE-CO FAULT IN MEMORY	FLASHING CODE 5	CYCLING CODE 5																																																	
TEST MODE-HP/UNDER	FLASHING CODE 6	CYCLING CODE 6																																																	
TEST MODE-HP/UNDER	FLASHING CODE 7	CYCLING CODE 7																																																	
TEST MODE-LPS IN MEMORY	FLASHING CODE 8	CYCLING CODE 8																																																	
TEST MODE-LPS IN MEMORY	FLASHING CODE 9	CYCLING CODE 9																																																	
SWAPPED PFI/FP2 LOCKOUT	FLASHING CODE 9	CYCLING CODE 9																																																	

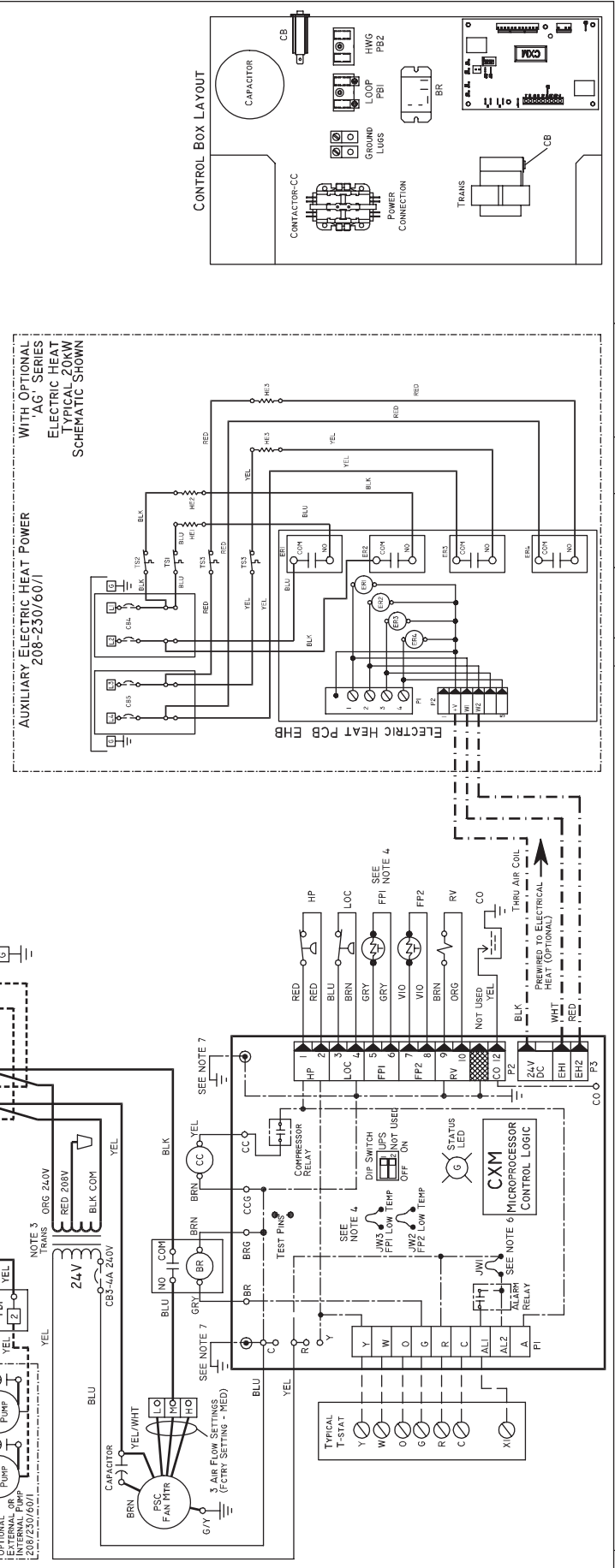

TYPICAL WIRING DIAGRAM - GT-PX & GT-PG UNITS WITH DXM BOARD, ECM FAN MOTOR, AND WHOLE HOUSE DEHUMIDIFICATION

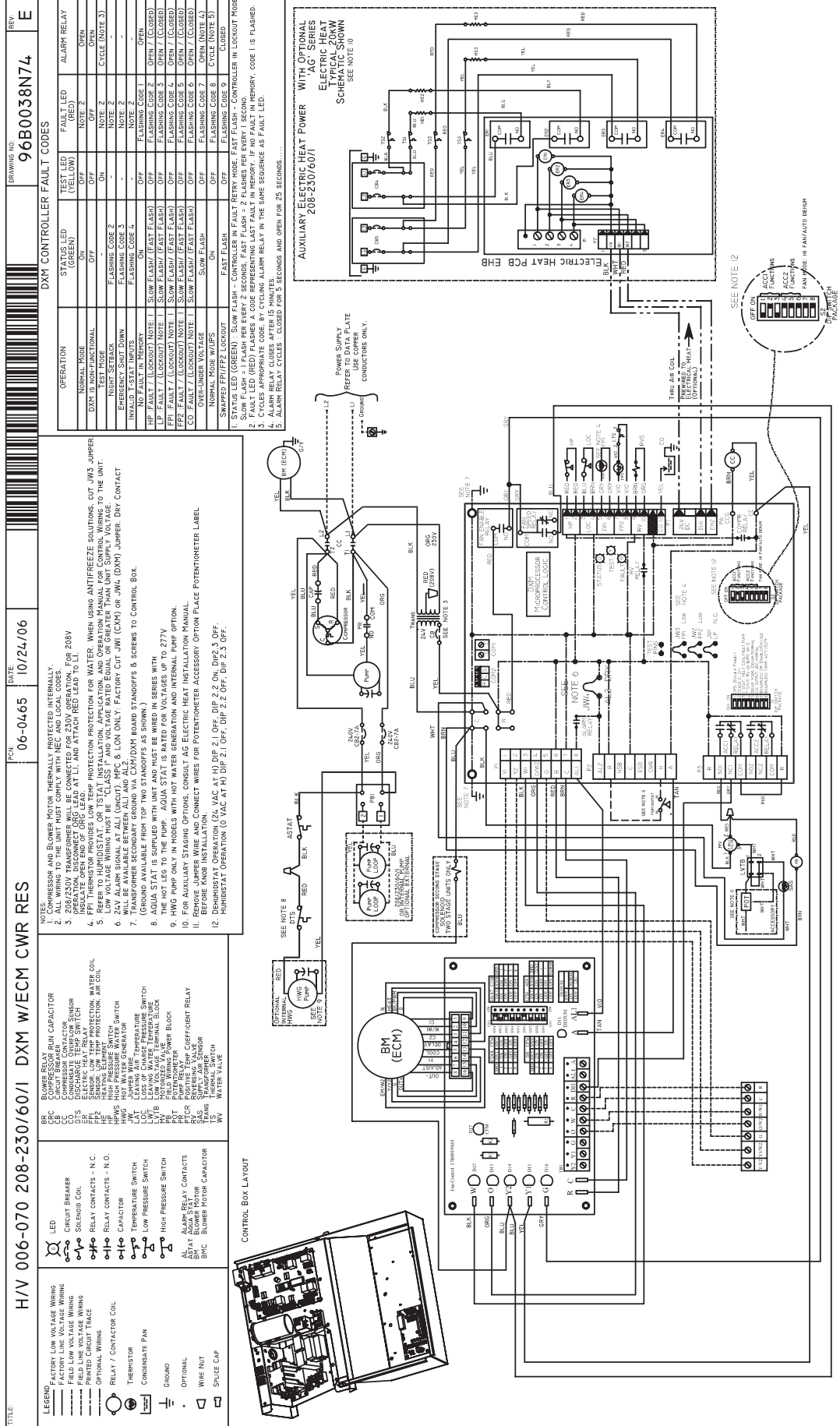

CXM CONTROLS

CXM Control

For detailed control information, see CXM/DXM Application, Operation and Maintenance (AOM) manual (part #97B0003N08).

Field Selectable Inputs

Test mode: Test mode allows the service technician to check the operation of the control in a timely manner. By momentarily shorting the test terminals, the CXM control enters a 20 minute test mode period in which all time delays are sped up 15 times. Upon entering test mode, the status LED will flash a code representing the last fault. For diagnostic ease at the thermostat, the alarm relay will also cycle during test mode. The alarm relay will cycle on and off similar to the status LED to indicate a code representing the last fault, at the thermostat. Test mode can be exited by shorting the test terminals for 3 seconds.

Retry Mode: If the control is attempting a retry of a fault, the status LED will slow flash (slow flash = one flash every 2 seconds) to indicate the control is in the process of retrying.

Field Configuration Options

Note: In the following field configuration options, jumper wires should be clipped **ONLY** when power is removed from the CXM control.

Water coil low temperature limit setting: Jumper 3 (JW3-FP1 Low Temp) provides field selection of temperature limit setting for FP1 of 30°F or 10°F [-1°F or -12°C] (refrigerant temperature).

Not Clipped = 30°F [-1°C]. Clipped = 10°F [-12°C].

Air coil low temperature limit setting: Jumper 2 (JW2-FP2 Low Temp) provides field selection of temperature limit setting for FP2 of 30°F or 10°F [-1°F or -12°C] (refrigerant temperature). Note: This jumper should only be clipped under extenuating circumstances, as recommended by the factory.

Not Clipped = 30°F [-1°C]. Clipped = 10°F [-12°C].

Alarm relay setting: Jumper 1 (JW1-AL2 Dry) provides field selection of the alarm relay terminal AL2 to be jumpered to 24VAC or to be a dry contact (no connection). *Not Clipped = AL2 connected to R. Clipped = AL2 dry contact (no connection).*

DIP Switches

Note: In the following field configuration options, DIP switches should only be changed when power is removed from the CXM control.

DIP switch 1: Unit Performance Sentinel Disable - provides field selection to disable the UPS feature. *On = Enabled. Off = Disabled.*

DIP switch 2: Stage 2 Selection - provides selection of whether compressor has an “on” delay. If set to stage 2, the compressor will have a 3 second delay before energizing. Also, if set for stage 2, the alarm relay will NOT cycle during test mode.

On = Stage 1. Off = Stage 2

DIP switch 3: Not Used.

DIP switch 4: DDC Output at EH2 - provides selection for DDC operation. If set to “DDC Output at EH2,” the EH2 terminal will continuously output the last fault code of the controller. If set to “EH2 normal,” EH2 will operate as standard electric heat output.

On = EH2 Normal. Off = DDC Output at EH2.

NOTE: Some CXM controls only have a 2 position DIP switch package. If this is the case, this option can be selected by clipping the jumper which is in position 4 of SW1.

Jumper not clipped = EH2 Normal. Jumper clipped = DDC Output at EH2.

DIP switch 5: Factory Setting - Normal position is “On.” Do not change selection unless instructed to do so by the factory.

Table 6a: CXM LED And Alarm Relay Operations

Description of Operation	LED	Alarm Relay
Normal Mode	On	Open
Normal Mode with UPS Warning	On	Cycle (closed 5 sec., Open 25 sec.)
CXM is non-functional	Off	Open
Fault Retry	Slow Flash	Open
Lockout	Fast Flash	Closed
Over/Under Voltage Shutdown	Slow Flash	Open (Closed after 15 minutes)
Test Mode - No fault in memory	Flashing Code 1	Cycling Code 1
Test Mode - HP Fault in memory	Flashing Code 2	Cycling Code 2
Test Mode - LP Fault in memory	Flashing Code 3	Cycling Code 3
Test Mode - FP1 Fault in memory	Flashing Code 4	Cycling Code 4
Test Mode - FP2 Fault in memory	Flashing Code 5	Cycling Code 5
Test Mode - CO Fault in memory	Flashing Code 6	Cycling Code 6
Test Mode - Over/Under shutdown in memory	Flashing Code 7	Cycling Code 7
Test Mode - UPS in memory	Flashing Code 8	Cycling Code 8
Test Mode - Swapped Thermistor	Flashing Code 9	Cycling Code 9

-Slow Flash = 1 flash every 2 seconds

-Fast Flash = 2 flashes every 1 second

-Flash code 2 = 2 quick flashes, 10 second pause, 2 quick flashes, 10 second pause, etc.

-On pulse 1/3 second; off pulse 1/3 second

CXM CONTROLS

Safety Features – CXM Control

The safety features below are provided to protect the compressor, heat exchangers, wiring and other components from damage caused by operation outside of design conditions.

Anti-short cycle protection: The control features a 5 minute anti-short cycle protection for the compressor.

Note: The 5 minute anti-short cycle also occurs at power up.

Random start: The control features a random start upon power up of 5-80 seconds.

Fault Retry: In Fault Retry mode, the Status LED begins slowly flashing to signal that the control is trying to recover from a fault input. The control will stage off the outputs and then “try again” to satisfy the thermostat input call. Once the thermostat input call is satisfied, the control will continue on as if no fault occurred. If 3 consecutive faults occur without satisfying the thermostat input call, the control will go into “lockout” mode. The last fault causing the lockout will be stored in memory and can be viewed by going into test mode. Note: FP1/FP2 faults are factory set at only one try.

Lockout: In lockout mode, the status LED will begin fast flashing. The compressor relay is turned off immediately. Lockout mode can be “soft” reset by turning off the thermostat (or satisfying the call). A “soft” reset keeps the fault in memory but resets the control. A “hard” reset (disconnecting power to the control) resets the control and erases fault memory.

Lockout with emergency heat: While in lockout mode, if W becomes active (CXM), emergency heat mode will occur.

High pressure switch: When the high pressure switch opens due to high refrigerant pressures, the compressor relay is de-energized immediately since the high pressure switch is in series with the compressor contactor coil. The high pressure fault recognition is immediate (does not delay for 30 continuous seconds before de-energizing the compressor).

High pressure lockout code = 2

Example: 2 quick flashes, 10 sec pause, 2 quick flashes, 10 sec. pause, etc.

Low pressure switch: The low pressure switch must be open and remain open for 30 continuous seconds during “on” cycle to be recognized as a low pressure fault. If the low pressure switch is open for 30 seconds prior to compressor power up it will be considered a low pressure (loss of charge) fault. The low pressure switch input is bypassed for the initial 60 seconds of a compressor run cycle.

Low pressure lockout code = 3

Water coil low temperature (FP1): The FP1 thermistor temperature must be below the selected low temperature limit setting for 30 continuous seconds during a compressor run cycle to be recognized as a FP1 fault. The FP1 input is bypassed for the initial 60 seconds of a compressor run cycle. FP1 is set at the factory for one try. Therefore, the control will go into lockout mode once the FP1 fault has occurred.

FP1 lockout code = 4

Air coil low temperature (FP2): The FP2 thermistor temperature must be below the selected low temperature limit setting for 30 continuous seconds during a

compressor run cycle to be recognized as a FP2 fault. The FP2 input is bypassed for the initial 60 seconds of a compressor run cycle. FP2 is set at the factory for one try. Therefore, the control will go into lockout mode once the FP2 fault has occurred.

FP2 lockout code = 5

Condensate overflow: The condensate overflow sensor must sense overflow level for 30 continuous seconds to be recognized as a CO fault. Condensate overflow will be monitored at all times.

CO lockout code = 6

Over/under voltage shutdown: An over/under voltage condition exists when the control voltage is outside the range of 19VAC to 30VAC. Over/under voltage shutdown is a self-resetting safety. If the voltage comes back within range for at least 0.5 seconds, normal operation is restored. This is not considered a fault or lockout. If the CXM is in over/under voltage shutdown for 15 minutes, the alarm relay will close.

Over/under voltage shut down code = 7

Unit Performance Sentinel-UPS (patent pending): The UPS feature indicates when the heat pump is operating inefficiently. A UPS condition exists when:

- a) In heating mode with compressor energized, FP2 is greater than 125°F [52°C] for 30 continuous seconds, or:
- b) In cooling mode with compressor energized, FP1 is greater than 125°F [52°C] for 30 continuous seconds, or:
- c) In cooling mode with compressor energized, FP2 is less than 40°F [4.5°C] for 30 continuous seconds. If a UPS condition occurs, the control will immediately go to UPS warning. The status LED will remain on as if the control is in normal mode. Outputs of the control, excluding LED and alarm relay, will NOT be affected by UPS. The UPS condition cannot occur during a compressor off cycle. During UPS warning, the alarm relay will cycle on and off. The cycle rate will be “on” for 5 seconds, “off” for 25 seconds, “on” for 5 seconds, “off” for 25 seconds, etc.

UPS warning code = 8

Swapped FP1/FP2 thermistors: During test mode, the control monitors to see if the FP1 and FP2 thermistors are in the appropriate places. If the control is in test mode, the control will lockout, with code 9, after 30 seconds if:

- a) The compressor is on in the cooling mode and the FP1 sensor is colder than the FP2 sensor, or:
- b) The compressor is on in the heating mode and the FP2 sensor is colder than the FP1 sensor.

Swapped FP1/FP2 thermistor code = 9.

Diagnostic Features

The LED on the CXM board advises the technician of the current status of the CXM control. The LED can display either the current CXM mode or the last fault in memory if in test mode. If there is no fault in memory, the LED will flash Code 1 (when in test mode).

CXM CONTROLS

CXM Control Start-up Operation

The control will not operate until all inputs and safety controls are checked for normal conditions. The compressor will have a 5 minute anti-short cycle delay at power-up. The first time after power-up that there is a call for compressor, the compressor will follow a 5 to 80 second random start delay. After the random start delay and anti-short cycle delay, the compressor relay will be energized. On all subsequent compressor calls, the random start delay is omitted.

Table 6b: Unit Operation

T-stat signal	GT-PX	GT-PG/GT-G	GT-PG/GT-G
	ECM fan	ECM fan	PSC fan
G	Fan only	Fan only	Fan only
G, Y or Y1	Stage 1 heating ¹	Stage 1 heating ³	Stage 1 heating ⁵
G, Y1, Y2	Stage 2 heating ¹	Stage 2 heating ³	Stage 2 heating ⁵
G, Y1, Y2, W	Stage 3 heating ¹	Stage 3 heating ³	N/A
G, W	Emergency heat	Emergency heat	Emergency heat
G, Y or Y1, O	Stage 1 cooling ²	Stage 1 cooling ⁴	Cooling ⁶
G, Y1, Y2, O	Stage 2 cooling ²	Stage 2 cooling ⁴	N/A

- 1 Stage 1 = 1st stage compressor, 1st stage fan operation
 Stage 2 = 2nd stage compressor, 2nd stage fan operation
 Stage 3 = 2nd stage compressor, auxiliary electric heat, 2nd or 3rd stage fan operation (depending on fan settings)
- 2 Stage 1 = 1st stage compressor, 1st stage fan operation, reversing valve
 Stage 2 = 2nd stage compressor, 2nd stage fan operation, reversing valve
- 3 Stage 1 = compressor, 1st stage fan operation
 Stage 2 = compressor, 2nd stage fan operation
 Stage 3 = compressor, auxiliary electric heat, 2nd or 3rd stage fan operation (depending on fan settings)
- 4 Stage 1 = compressor, 1st stage fan operation, reversing valve
 Stage 2 = compressor, 2nd stage fan operation, reversing valve
- 5 Stage 1 = compressor, fan
 Stage 2 = compressor, auxiliary electric heat, fan
- 6 Cooling = compressor, fan, reversing valve

CXM CONTROLS

Table 7: Nominal resistance at various temperatures

Temp (°C)	Temp (°F)	Resistance (kOhm)	Temp (°C)	Temp (°F)	Resistance (kOhm)
-17.8	0.0	85.41	55	131.0	2.99
-17.5	0.5	84.16	56	132.8	2.88
-16.9	1.5	81.43	57	134.6	2.77
-12	10.4	61.70	58	136.4	2.67
-11	12.2	58.40	59	138.2	2.58
-10	14.0	55.30	60	140.0	2.49
-9	15.8	52.40	61	141.8	2.40
-8	17.6	49.60	62	143.6	2.32
-7	19.4	47.00	63	145.4	2.23
-6	21.2	44.60	64	147.2	2.16
-5	23.0	42.30	65	149.0	2.08
-4	24.8	40.10	66	150.8	2.01
-3	26.6	38.10	67	152.6	1.94
-2	28.4	36.10	68	154.4	1.88
-1	30.2	34.30	69	156.2	1.81
0	32.0	32.60	70	158.0	1.75
1	33.8	31.00	71	159.8	1.69
2	35.6	29.40	72	161.6	1.64
3	37.4	28.00	73	163.4	1.58
4	39.2	26.60	74	165.2	1.53
5	41.0	25.30	75	167.0	1.48
6	42.8	24.10	76	168.8	1.43
7	44.6	23.00	77	170.6	1.38
8	46.4	21.90	78	172.4	1.34
9	48.2	20.80	79	174.2	1.30
10	50.0	19.90	80	176.0	1.26
11	51.8	18.97	81	177.8	1.22
12	53.6	18.09	82	179.6	1.18
13	55.4	17.25	83	181.4	1.14
14	57.2	16.46	84	183.2	1.10
15	59.0	15.71	85	185.0	1.07
16	60.8	15.00	86	186.8	1.04
17	62.6	14.32	87	188.6	1.00
18	64.4	13.68	88	190.4	0.97
19	66.2	13.07	89	192.2	0.94
20	68.0	12.49	90	194.0	0.92
21	69.8	11.94	91	195.8	0.89
22	71.6	11.42	92	197.6	0.86
23	73.4	10.92	93	199.4	0.84
24	75.2	10.45	94	201.2	0.81
25	77.0	10.00	95	203.0	0.79
26	78.8	9.57	96	204.8	0.76
27	80.6	9.17	97	206.6	0.74
28	82.4	8.78	98	208.4	0.72
29	84.2	8.41	99	210.2	0.70
30	86.0	8.06	100	212.0	0.68
31	87.8	7.72	101	213.8	0.66
32	89.6	7.40	102	215.6	0.64
33	91.4	7.10	103	217.4	0.62
34	93.2	6.81	104	219.2	0.60
35	95.0	6.53	105	221.0	0.59
36	96.8	6.27	106	222.8	0.57
37	98.6	6.02	107	224.6	0.56
38	100.4	5.78	108	226.4	0.54
39	102.2	5.55	109	228.2	0.53
40	104.0	5.33	110	230.0	0.51
41	105.8	5.12	111	231.8	0.50
42	107.6	4.92	112	233.6	0.48
43	109.4	4.73	113	235.4	0.47
44	111.2	4.54	114	237.2	0.46
45	113.0	4.37	115	239.0	0.45
46	114.8	4.20	116	240.8	0.43
47	116.6	4.04	117	242.6	0.42
48	118.4	3.89	118	244.4	0.41
49	120.2	3.74	119	246.2	0.40
50	122.0	3.60	120	248.0	0.39
51	123.8	3.47	121	249.8	0.38
52	125.6	3.34	122	251.6	0.37
53	127.4	3.22	123	253.4	0.36
54	129.2	3.10			

Rev.: 5/23/00 m

CXM Thermostat Details

Thermostat Compatibility - Most all heat pump thermostats can be used with the CXM control. **However Heat/Cool stats are NOT compatible with the CXM.**

Anticipation Leakage Current - Maximum leakage current for "Y" is 50 mA and for "W" is 20mA. Triacs can be used if leakage current is less than above. Thermostats with anticipators can be used if anticipation current is less than that specified above.

Thermostat Signals -

- "Y" and "W" have a 1 second recognition time when being activated or being removed.
- "O" and "G" are direct pass through signals but are monitored by the micro processor.
- "R" and "C" are from the transformer.
- "AL1" and "AL2" originate from the alarm relay.
- "A" is paralleled with the compressor output for use with well water solenoid valves.
- The "Y" 1/4" quick connect is a connection point to the "Y" input terminal P1 for factory use. This "Y" terminal can be used to drive panel mounted relays such as the loop pump relay.

UNIT STARTING AND OPERATING CONDITIONS

Operating Limits

Environment – Units are designed for indoor installation only. Never install units in areas subject to freezing or where humidity levels could cause cabinet condensation (such as unconditioned spaces subject to 100% outside air).

Power Supply – A voltage variation of +/- 10% of nameplate utilization voltage is acceptable.

Starting Conditions

Consult Table 8 for the particular model. Starting conditions vary depending upon model and are based upon the following notes:

Notes:

1. Conditions in Table 8 are not normal or continuous operating conditions. Minimum/maximum limits are start-up conditions to bring the building space up to occupancy temperatures. Units are not designed to operate under these conditions on a regular basis.

2. Voltage utilization range complies with ARI Standard 110.

Determination of operating limits is dependent primarily upon three factors: 1) return air temperature. 2) water temperature, and 3) ambient temperature. When any one of these factors is at minimum or maximum levels, the other two factors should be at normal levels to insure proper unit operation.

Extreme variations in temperature and humidity and/or corrosive water or air will adversely affect unit performance, reliability, and service life.

Table 8: Operating Limits

Operating Limits	GT-PX/GT-PG		GT-G	
	Cooling	Heating	Cooling	Heating
Air Limits				
Min. ambient air, DB	45°F [7°C]	39°F [4°C]	45°F [7°C]	39°F [4°C]
Rated ambient air, DB	80.6°F [27°C]	68°F [20°C]	80.6°F [27°C]	68°F [20°C]
Max. ambient air, DB	110°F [43°C]	85°F [29°C]	110°F [43°C]	85°F [29°C]
Min. entering air, DB/WB	50°F [10°C]	40°F [4.5°C]	50°F [10°C]	50°F [10°C]
Rated entering air, DB/WB	80.6/66.2°F [27/19°C]	68°F [20°C]	80.6/66.2°F [27/19°C]	68°F [20°C]
Max. entering air, DB/WB	110/83°F [43/28°C]	80°F [27°C]	110/83°F [43/28°C]	80°F [27°C]
Water Limits				
Min. entering water	30°F [-1°C]	20°F [-6.7°C]	30°F [-1°C]	20°F [-6.7°C]
Normal entering water	50-110°F [10-43°C]	30-70°F [-1 to 21°C]	50-110°F [10-43°C]	30-70°F [-1 to 21°C]
Max. entering water	120°F [49°C]	90°F [32°C]	120°F [49°C]	90°F [32°C]
Normal water flow	1.5 to 3.0 gpm/ton		1.5 to 3.0 gpm/ton	
	2.0 to 3.9 l/m per kW		2.0 to 3.9 l/m per kW	

UNIT STARTING AND OPERATING CONDITIONS

Unit and System Checkout

BEFORE POWERING SYSTEM, please check the following:

UNIT CHECKOUT

- Balancing/shutoff valves: Insure that all isolation valves are open and water control valves are wired.
- Line voltage and wiring: Verify that voltage is within an acceptable range for the unit and wiring and fuses/breakers are properly sized. Verify that low voltage wiring is complete.
- Unit control transformer: Insure that transformer has the properly selected voltage tap. Residential 208-230V units are factory wired for 230V operation unless specified otherwise.
- Loop/water piping is complete and purged of air. Water/piping is clean.
- Antifreeze has been added if necessary.
- Entering water and air: Insure that entering water and air temperatures are within operating limits of Table 8.
- Low water temperature cutout: Verify that low water temperature cut-out on the CXM/DXM control is properly set.
- Unit fan: Manually rotate fan to verify free rotation and insure that blower wheel is secured to the motor shaft. Be sure to remove any shipping supports if needed. DO NOT oil motors upon start-up. Fan motors are pre-oiled at the factory. Check unit fan speed selection and compare to design requirements.
- Condensate line: Verify that condensate line is open and properly pitched toward drain.
- HWG pump is disconnected unless piping is completed and air has been purged from the system.
- Water flow balancing: Record inlet and outlet water temperatures for each heat pump upon startup. This check can eliminate nuisance trip outs and high velocity water flow that could erode heat exchangers.
- Unit air coil and filters: Insure that filter is clean and accessible. Clean air coil of all manufacturing oils.
- Unit controls: Verify that CXM field selection options are properly set. Low voltage wiring is complete.
- Blower speed is set.
- Service/access panels are in place.

SYSTEM CHECKOUT

- System water temperature: Check water temperature for proper range and also verify heating and cooling set points for proper operation.
- System pH: Check and adjust water pH if necessary to maintain a level between 6 and 8.5. Proper pH promotes longevity of hoses and fittings (see Table 3).
- System flushing: Verify that all air is purged from the system. Air in the system can cause poor operation or system corrosion. Water used in the system must be potable quality initially and clean of dirt, piping slag, and strong chemical cleaning agents. Some antifreeze solutions may require distilled water.

- Flow Controller pump(s): Verify that the pump(s) is wired and in operating condition.
- System controls: Verify that system controls function and operate in the proper sequence.
- Low water temperature cutout: Verify that low water temperature cut-out controls are set properly (FP1 - JW3).
- Miscellaneous: Note any questionable aspects of the installation.

⚠ CAUTION! ⚠

CAUTION! Verify that ALL water control valves are open and allow water flow prior to engaging the compressor. Freezing of the coax or water lines can permanently damage the heat pump.

NOTICE! Failure to remove shipping brackets from spring-mounted compressors will cause excessive noise, and could cause component failure due to added vibration.

⚠ CAUTION! ⚠

CAUTION! To avoid equipment damage, DO NOT leave system filled in a building without heat during the winter unless antifreeze is added to the water loop. Heat exchangers never fully drain by themselves and will freeze unless winterized with antifreeze.

Unit Start-up Procedure

1. Turn the thermostat fan position to "ON." Blower should start.
2. Balance air flow at registers.
3. Adjust all valves to their full open position. Turn on the line power to all heat pump units.
4. Room temperature should be within the minimum-maximum ranges of Table 8. During start-up checks, loop water temperature entering the heat pump should be between 30°F [-1°C] and 95°F [35°C].
5. Two factors determine the operating limits of water source heat pumps, (a) return air temperature, and (b) water temperature. When any one of these factors is at a minimum or maximum level, the other factor must be at normal level to insure proper unit operation.
 - a. Adjust the unit thermostat to the warmest setting. Place the thermostat mode switch in the "COOL" position. Slowly reduce thermostat setting until the compressor activates.

UNIT START-UP PROCEDURE

- b. Check for cool air delivery at the unit grille within a few minutes after the unit has begun to operate.
Note: Units have a five minute time delay in the control circuit that can be eliminated on the CXM/DXM control board as shown below in Figure 30. See controls description for details.
 - c. Verify that the compressor is on and that the water flow rate is correct by measuring pressure drop through the heat exchanger using the P/T plugs and comparing to Tables 9a through 9c.
 - d. Check the elevation and cleanliness of the condensate lines. Dripping may be a sign of a blocked line. Check that the condensate trap is filled to provide a water seal.
 - e. Refer to Table 10. Check the temperature of both entering and leaving water. If temperature is within range, proceed with the test. If temperature is outside of the operating range, check refrigerant pressures and compare to Tables 11 through 13. Verify correct water flow by comparing unit pressure drop across the heat exchanger versus the data in Tables 9a through 9c. Heat of rejection (HR) can be calculated and compared to catalog data capacity pages. The formula for HR for systems with water is as follows:
$$HR = TD \times GPM \times 500$$
where TD is the temperature difference between the entering and leaving water, and GPM is the flow rate in U.S. GPM, determined by comparing the pressure drop across the heat exchanger to Tables 9a through 9c.
 - f. Check air temperature drop across the air coil when compressor is operating. Air temperature drop should be between 15°F and 25°F [8°C and 14°C].
 - g. Turn thermostat to "OFF" position. A hissing noise indicates proper functioning of the reversing valve.
6. Allow five (5) minutes between tests for pressure to equalize before beginning heating test.
 - a. Adjust the thermostat to the lowest setting. Place the thermostat mode switch in the "HEAT" position.
 - b. Slowly raise the thermostat to a higher temperature until the compressor activates.
 - c. Check for warm air delivery within a few minutes after the unit has begun to operate.
 - d. Refer to Table 10. Check the temperature of both entering and leaving water. If temperature is within range, proceed with the test. If temperature is outside of the operating range, check refrigerant pressures and compare to Tables 11 through 13. Verify correct water flow by comparing unit pressure drop across the heat exchanger versus the data in Tables 9a through 9c. Heat of extraction (HE) can be calculated and compared to submittal data capacity pages. The formula for HE for systems with water is as follows:
$$HE = TD \times GPM \times 500$$
where TD is the temperature difference between the entering and leaving water, and GPM is the flow rate in U.S.

- e. Check air temperature rise across the air coil when compressor is operating. Air temperature rise should be between 20°F and 30°F [11°C and 17°C].
 - f. Check for vibration, noise, and water leaks.
7. If unit fails to operate, perform troubleshooting analysis (see troubleshooting section). If the check described fails to reveal the problem and the unit still does not operate, contact a trained service technician to insure proper diagnosis and repair of the equipment.
 8. When testing is complete, set system to maintain desired comfort level.
 9. **BE CERTAIN TO FILL OUT AND RETURN ALL WARRANTY REGISTRATION PAPERWORK.**

Note: If performance during any mode appears abnormal, refer to the CXM section or troubleshooting section of this manual. To obtain maximum performance, the air coil should be cleaned before start-up. A 10% solution of dishwasher detergent and water is recommended.

▲ WARNING! ▲

WARNING! When the disconnect switch is closed, high voltage is present in some areas of the electrical panel. Exercise caution when working with energized equipment.

▲ CAUTION! ▲

CAUTION! Verify that ALL water control valves are open and allow water flow prior to engaging the compressor. Freezing of the coax or water lines can permanently damage the heat pump.

Figure 30: Test Mode Pins

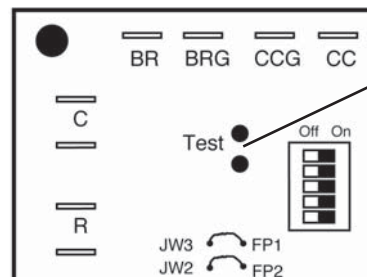

Short test pins together to enter Test Mode and speed-up timing and delays for 20 minutes.

UNIT OPERATING CONDITIONS

Table 9a: GT-PX Coax Water Pressure Drop

Model	GPM	Pressure Drop (psi)			
		30°F	50°F	70°F	90°F
026	4.0	1.5	1.3	1.1	1.0
	6.0	3.1	2.6	2.3	2.1
	7.0	4.1	3.4	3.0	2.7
	8.0	5.1	4.3	3.8	3.4
038	4.0	1.2	1.0	0.8	0.6
	6.0	2.6	2.5	2.3	2.1
	8.0	4.5	4.2	4.0	3.7
	9.0	5.7	5.2	4.8	4.4
049	5.5	1.1	0.9	0.8	0.7
	8.3	2.2	2.1	2.0	1.8
	11.0	3.9	3.6	3.2	3.1
	12.0	4.5	4.2	3.8	3.5
064	7.0	0.5	0.3	0.2	0.1
	10.5	1.9	1.8	1.7	1.6
	14.0	3.9	3.5	3.2	2.9
	15.0	4.8	4.3	3.9	3.5
072	7.5	1.7	1.5	1.3	1.3
	11.3	3.9	3.4	3.0	2.8
	15.0	6.9	6.0	5.4	5.0
	17.0	8.9	7.7	6.9	6.5

Table 9b: GT-PG Coax Water Pressure Drop

Model	GPM	Pressure Drop (psi)			
		30°F	50°F	70°F	90°F
018	2.8	0.7	0.5	0.3	0.2
	4.1	2.1	1.7	1.4	1.1
	5.5	3.5	2.8	2.4	2.0
024	4.0	1.5	1.3	1.1	1.0
	6.0	3.1	2.6	2.3	2.1
	8.0	5.1	4.3	3.8	3.4
030	4.0	1.5	1.3	1.1	1.0
	6.0	3.1	2.6	2.3	2.1
	8.0	5.1	4.3	3.8	3.4
036	4.5	1.7	1.3	1.1	0.9
	6.8	3.3	3.1	2.9	2.6
	9.0	5.7	5.2	4.8	4.4
042	5.5	1.1	0.9	0.8	0.7
	8.3	2.2	2.1	2.0	1.8
	11.0	3.9	3.6	3.2	3.1
048	6.0	1.3	1.1	1.0	0.9
	9.0	2.6	2.5	2.3	2.2
	12.0	4.5	4.2	3.8	3.5
060	7.5	0.6	0.4	0.3	0.2
	11.3	2.3	2.1	2.0	1.8
	15.0	4.8	4.3	3.9	3.5
070	8.3	2.4	2.0	1.7	1.6
	12.4	5.2	4.5	4.0	3.8
	16.5	8.0	7.0	6.3	6.0

Table 9c: GT-G Coax Water Pressure Drop

Model	GPM	Pressure Drop (psi)			
		30°F	50°F	70°F	90°F
015	1.8	0.6	0.5	0.5	0.5
	2.8	1.0	0.9	0.8	0.8
	3.8	1.5	1.4	1.3	1.2
018	2.2	0.7	0.7	0.6	0.6
	3.5	1.3	1.2	1.1	1.1
	4.5	1.8	1.8	1.6	1.5
024	3.0	0.6	0.6	0.5	0.5
	4.5	1.1	1.1	1.0	0.9
	6.0	1.8	1.7	1.5	1.5
030	3.7	0.8	0.8	0.7	0.7
	5.5	1.6	1.4	1.3	1.3
	7.5	2.6	2.4	2.2	2.1
036	4.5	1.3	1.2	1.1	1.1
	7.0	2.1	1.9	1.7	1.7
	9.0	3.9	3.7	3.4	3.2
042	5.5	1.6	1.5	1.4	1.3
	8.0	3.2	3.0	2.8	2.6
	10.5	5.1	4.7	4.4	4.1
048	6.0	2.1	1.9	1.8	1.7
	9.0	3.9	3.7	3.4	3.2
	12.0	6.4	5.9	5.5	5.2
060	7.5	1.1	1.0	1.0	0.9
	11.3	2.2	2.1	1.9	1.8
	15.0	3.6	3.4	3.1	3.0
070	9.0	1.5	1.4	1.3	1.2
	13.5	3.0	2.8	2.6	2.5
	18.0	5.0	4.7	4.3	4.1

Table 10: Water Temperature Change Through Heat Exchanger

Water Flow, gpm (l/m)	Rise, Cooling °F (°C)	Drop, Heating °F (°C)
For Closed Loop: Ground Source or Closed Loop Systems at 3 gpm per ton (3.9 l/m per kw)	9 - 12 (5 - 6.7)	4 - 8 (2.2 - 4.4)
For Open Loop: Ground Water Systems at 1.5 gpm per ton (2.0 l/m per kw)	20 - 26 (11.1 - 14.4)	10 - 17 (5.6 - 9.4)

UNIT OPERATING CONDITIONS

Table 11: GT-PX Series Typical Unit Operating Pressures and Temperatures

026		Full Load Cooling - without HWG active						Full Load Heating - without HWG active					
Entering Water Temp °F	Water Flow GPM/ton	Suction Pressure PSIG	Discharge Pressure PSIG	Superheat	Subcooling	Water Temp Rise °F	Air Temp Drop °F DB	Suction Pressure PSIG	Discharge Pressure PSIG	Superheat	Subcooling	Water Temp Drop °F	Air Temp Rise °F DB
30	1.5	118-128	159-179	25-30	9-14	16.7-18.7	19-25	72-83	273-293	6-11	3-8	5.9-7.9	16-22
	2.25	118-128	146-166	25-30	7-12	12.3-14.3	20-26	75-85	275-295	6-11	3-8	4.2-6.2	17-23
	3	118-128	132-152	25-30	7-12	7.9-9.9	20-26	78-88	277-297	6-11	3-8	2.7-4.7	18-24
50	1.5	128-138	186-206	18-23	8-13	16.3-18.3	19-25	102-112	302-322	8-12	6-11	8.9-10.9	22-28
	2.25	128-138	172-192	18-23	6-11	12.1-14.1	20-26	106-116	303-323	8-12	6-11	6.7-8.7	23-29
	3	128-138	158-178	18-23	6-11	7.8-9.8	20-26	110-120	305-325	8-12	6-11	4.5-6.5	23-29
70	1.5	136-146	281-301	7-12	7-12	15.7-17.7	19-25	118-138	330-350	10-15	8-13	11.3-13.3	27-34
	2.25	136-146	267-287	7-12	5-10	11.6-13.6	19-25	134-144	332-352	10-15	8-13	8.5-10.5	28-35
	3	136-146	253-273	7-12	4-9	7.6-9.6	19-25	141-151	334-354	10-15	8-13	5.8-7.8	28-35
90	1.5	139-149	368-388	6-11	7-12	14.9-16.9	18-24	162-172	367-387	14-19	10-15	14.4-16.4	33-41
	2.25	139-149	354-374	6-11	5-10	11-13	18-24	166-176	372-392	15-20	10-15	10.8-12.8	34-42
	3	139-149	340-360	6-11	5-10	7.2-9.2	18-24	171-181	377-397	17-22	10-15	7.1-9.1	34-42
110	1.5	143-153	465-485	6-11	7-12	13.9-15.9	17-23						
	2.25	143-153	450-470	6-11	5-10	10.2-12.2	17-23						
	3	143-153	433-453	6-11	5-10	6.5-8.5	17-23						

038		Full Load Cooling - without HWG active						Full Load Heating - without HWG active					
Entering Water Temp °F	Water Flow GPM/ton	Suction Pressure PSIG	Discharge Pressure PSIG	Superheat	Subcooling	Water Temp Rise °F	Air Temp Drop °F DB	Suction Pressure PSIG	Discharge Pressure PSIG	Superheat	Subcooling	Water Temp Drop °F	Air Temp Rise °F DB
30	1.5	120-130	156-176	25-30	9-14	22.1-24.1	18-24	69-79	293-313	7-12	14-19	8.9-10.9	17-23
	2.25	119-129	148-168	25-30	8-13	16.8-18.8	19-25	73-83	297-317	7-12	14-19	6.7-8.7	18-24
	3	119-129	138-158	25-30	8-13	10.5-12.5	19-25	76-86	300-320	7-12	14-19	4.5-6.5	19-25
50	1.5	129-139	225-245	15-20	10-15	21.9-23.9	18-24	96-106	322-342	10-15	17-22	12.2-14.2	23-29
	2.25	128-138	211-231	15-20	9-14	16.1-18.1	19-25	100-110	326-346	10-15	17-22	9.3-11.3	24-30
	3	128-138	197-217	15-20	9-14	10.3-12.3	19-25	105-115	331-351	10-15	17-22	6.4-8.4	24-30
70	1.5	136-146	302-322	9-14	13-18	21.5-23.5	18-24	123-133	352-372	11-16	19-24	15-17	28-35
	2.25	135-145	283-303	9-14	12-17	15.8-17.8	19-25	129-139	358-378	11-16	19-24	11.6-13.6	29-36
	3	135-145	265-285	9-14	12-17	10-12	19-25	135-145	364-384	11-16	19-24	8.2-10.2	30-37
90	1.5	140-150	390-410	7-12	13-18	20.5-22.5	17-23	157-167	390-410	13-18	18-23	21-23	36-44
	2.25	140-150	369-389	8-13	8-13	14.9-16.9	17-23	169-179	399-419	13-18	16.5-21.5	15.5-17.5	37-45
	3	140-150	349-369	8-13	8-13	9.3-11.3	17-23	181-191	408-428	14-19	15-20	10.5-12.5	39-47
110	1.5	145-155	488-508	7-12	13-18	19-21	17-23						
	2.25	145-155	467-487	8-13	8-13	14-16	17-23						
	3	145-155	447-467	8-13	8-13	9-11	17-23						

049		Full Load Cooling - without HWG active						Full Load Heating - without HWG active					
Entering Water Temp °F	Water Flow GPM/ton	Suction Pressure PSIG	Discharge Pressure PSIG	Superheat	Subcooling	Water Temp Rise °F	Air Temp Drop °F DB	Suction Pressure PSIG	Discharge Pressure PSIG	Superheat	Subcooling	Water Temp Drop °F	Air Temp Rise °F DB
30	1.5	112-122	187-207	22-27	14-19	20.7-22.7	18-24	66-76	286-306	7-12	8-13	8-10	18-24
	2.25	111-121	167-187	22-27	12-17	15.5-17.5	18-24	69-79	289-309	7-12	9-14	6-8	19-25
	3	111-121	147-167	23-28	11-16	10.2-12.2	18-24	72-82	292-312	7-12	9-14	4-6	19-25
50	1.5	125-135	242-262	13-18	10-15	20.9-22.9	19-25	93-103	314-334	8-13	10-15	11.5-13.5	23-29
	2.25	123-133	224-244	13-18	9-14	15.6-17.6	19-25	98-108	320-340	8-13	10-15	8.7-10.7	24-30
	3	122-132	205-225	14-19	7-12	10.2-12.2	19-25	103-113	326-346	8-13	10-15	5.9-7.9	25-31
70	1.5	133-143	310-330	8-13	8-13	20.5-22.5	19-25	123-133	344-364	9-14	9-14	15-17	28-35
	2.25	132-142	290-310	8-13	7-12	15.2-17.2	19-25	130-140	354-374	9-14	9-14	11.5-13.5	29-36
	3	131-141	270-290	9-14	5-10	9.9-11.9	19-25	137-147	361-381	9-14	9-14	7.9-9.9	30-37
90	1.5	138-148	396-416	7-12	7-12	19.2-21.2	18-24	165-175	390-410	13-18	8-13	19.6-21.6	37-45
	2.25	137-147	374-394	7-12	6-11	14.3-16.3	18-24	175-185	401-421	15-20	8-13	15-17	38-46
	3	136-146	352-372	7-12	4-9	9.3-11.3	18-24	185-195	413-433	17-22	8-13	10.3-12.3	39-47
110	1.5	144-154	497-517	7-12	5-10	18-20	17-23						
	2.25	143-153	472-492	7-12	4-9	13.3-15.3	17-23						
	3	142-152	447-467	7-12	3-8	8.5-10.5	17-23						

UNIT OPERATING CONDITIONS

Table 11: GT-PX Series Typical Unit Operating Pressures and Temperatures: Continued

064		Full Load Cooling - without HWG active						Full Load Heating - without HWG active					
Entering Water Temp °F	Water Flow GPM/ton	Suction Pressure PSIG	Discharge Pressure PSIG	Superheat	Subcooling	Water Temp Rise °F	Air Temp Drop °F DB	Suction Pressure PSIG	Discharge Pressure PSIG	Superheat	Subcooling	Water Temp Drop °F	Air Temp Rise °F DB
30	1.5	117-127	170-190	27-32	15-20	18.2-20.2	17-23	66-76	282-302	10-16	9-14	8-10	19-25
	2.25	116-126	143-163	28-33	13-18	12.6-14.6	17-23	69-79	285-305	10-16	9-14	6-8	19-25
	3	115-125	135-155	29-34	12-17	7-9	17-23	72-82	289-309	10-16	10-15	4-6	20-26
50	1.5	128-138	238-258	16-21	14-19	20.5-22.5	21-27	90-100	310-330	11-17	12-17	11.3-13.3	24-30
	2.25	126-136	222-242	21-26	13-18	14.9-16.9	21-27	95-105	313-333	11-17	12-17	8.5-10.5	25-31
	3	125-135	205-225	26-31	12-17	9.2-11.2	21-27	99-109	316-336	11-17	12-17	5.7-7.7	26-32
70	1.5	135-145	315-335	10-15	14-19	21-23	22-28	115-125	337-357	12-18	14-19	14-17	28-35
	2.25	134-144	296-316	12-17	13-18	15.5-17.5	22-28	120-130	341-361	12-18	14-19	10.6-12.6	29-36
	3	133-143	276-296	15-20	11-16	10-12	22-28	126-136	345-365	12-18	15-20	7.3-9.3	30-37
90	1.5	139-149	408-428	10-15	15-20	20.1-22.1	21-27	157-167	390-410	15-20	14-19	18.2-20.2	37-45
	2.25	138-148	386-406	10-15	13-18	14.8-16.8	21-27	161-171	394-414	15-20	14-19	13.9-15.9	38-46
	3	138-148	364-384	10-15	11-16	9.5-11.5	21-27	166-176	398-418	15-20	15-20	9.6-11.6	39-47
110	1.5	144-154	515-535	8-13	14-19	19-21	20-26						
	2.25	143-153	493-513	8-13	13-18	14-16	20-26						
	3	142-152	469-489	8-13	12-17	9-11	20-26						

072		Full Load Cooling - without HWG active						Full Load Heating - without HWG active					
Entering Water Temp °F	Water Flow GPM/ton	Suction Pressure PSIG	Discharge Pressure PSIG	Superheat	Subcooling	Water Temp Rise °F	Air Temp Drop °F DB	Suction Pressure PSIG	Discharge Pressure PSIG	Superheat	Subcooling	Water Temp Drop °F	Air Temp Rise °F DB
30	1.5	119-129	155-175	25-30	17-22	18-20	21-27	61-71	292-312	11-16	13-18	7.2-9.2	19-25
	2.25	117-127	150-170	25-30	17-22	13.2-15.2	21-27	65-75	296-316	11-16	14-19	5.4-7.4	20-26
	3	115-125	144-164	28-32	17-22	8.4-9.4	22-28	68-78	300-320	10-15	15-20	3.5-5.5	21-27
50	1.5	131-141	210-230	10-15	12-17	18.5-20.5	22-28	89-99	327-347	10-15	19-24	10.9-12.9	26-32
	2.25	130-140	205-225	11-16	12-17	14-16	23-29	98-108	337-357	10-15	14-19	8.3-10.3	28-34
	3	129-139	200-220	13-18	12-17	9.5-11.5	24-30	106-116	348-368	10-15	9-14	5.7-7.7	30-36
70	1.5	135-145	300-320	10-15	15-20	17.6-19.6	23-29	119-129	365-385	10-15	21-26	14.7-16.7	33-39
	2.25	131-141	295-315	11-16	14-19	13.8-15.8	23-29	132-142	380-400	10-15	16-21	11.3-13.3	36-42
	3	128-138	290-310	13-18	14-19	10-12	23-29	144-154	395-415	10-15	11-16	7.9-9.9	38-44
90	1.5	139-149	390-410	10-15	16-21	16.7-18.7	22-28	162-172	418-438	10-15	19-24	19.4-21.4	43-49
	2.25	137-147	370-390	10-15	14-19	12.6-14.6	22-28	172-182	430-450	10-15	19-24	14.7-16.7	45-51
	3	135-145	350-370	10-15	13-18	8.5-10.5	22-28	182-192	444-464	11-16	19-24	10.1-12.1	47-53
110	1.5	145-155	490-510	10-15	16-21	15.9-17.9	20-27						
	2.25	145-155	470-490	10-15	14-19	11.7-13.7	20-27						
	3	144-154	452-472	9-14	13-18	7.4-9	20-27						

Table 12: GT-PG Series Typical Unit Operating Pressures and Temperatures

018		Full Load Cooling - without HWG active						Full Load Heating - without HWG active					
Entering Water Temp °F	Water Flow GPM/ton	Suction Pressure PSIG	Discharge Pressure PSIG	Superheat	Subcooling	Water Temp Rise °F	Air Temp Drop °F DB	Suction Pressure PSIG	Discharge Pressure PSIG	Superheat	Subcooling	Water Temp Drop °F	Air Temp Rise °F DB
30	1.5	120-130	155-175	27-32	11-16	16.9-19.9	16-22	73-83	268-288	8-13	4-9	6.1-8.1	15-21
	2.25	120-130	142-162	27-32	9-14	12.5-14.5	17-23	75-85	270-290	8-13	4-9	4.4-6.4	16-22
	3	120-130	128-148	27-32	9-14	8.1-10.1	17-23	78-88	272-292	8-13	4-9	2.9-4.9	16-22
50	1.5	137-147	220-240	16-21	10-15	17-19	16-22	102-112	295-315	8-13	8-13	9.1-11.1	20-26
	2.25	137-147	206-226	16-21	8-13	12.6-14.6	17-23	106-116	297-317	8-13	8-13	6.9-8.9	21-27
	3	137-147	192-212	16-21	8-13	8.4-10.4	17-23	110-120	299-319	8-13	8-13	4.7-6.7	21-27
70	1.5	142-152	287-307	7-12	10-15	15.9-17.9	16-22	131-141	324-344	9-14	10-15	12.1-14.1	25-33
	2.25	142-152	273-293	7-12	8-13	11.8-13.8	17-23	137-147	326-346	9-14	10-15	9.3-11.3	26-34
	3	142-152	259-279	7-12	8-13	7.8-9.8	17-23	144-154	328-348	9-14	10-15	6.6-8.6	26-34
90	1.5	146-156	375-395	6-11	10-15	14.9-16.9	16-22	174-184	360-380	10-15	12-17	15.8-17.8	32-40
	2.25	146-156	361-381	6-11	8-13	11-13	17-23	180-190	367-387	11-16	12-17	11.9-13.9	33-41
	3	146-156	347-367	6-11	8-13	7.2-9.2	17-23	187-197	374-394	12-17	12-17	8-10	33-41
110	1.5	154-164	478-498	6-11	10-15	14-16	16-22						
	2.25	154-164	461-481	6-11	8-13	10.2-12.2	16-22						
	3	154-164	445-465	6-11	8-13	6.5-8.5	16-22						

UNIT OPERATING CONDITIONS

Table 12: GT-PG Series Typical Unit Operating Pressures and Temperatures: Continued

024		Full Load Cooling - without HWG active						Full Load Heating - without HWG active					
Entering Water Temp °F	Water Flow GPM/ton	Suction Pressure PSIG	Discharge Pressure PSIG	Superheat	Subcooling	Water Temp Rise °F	Air Temp Drop °F DB	Suction Pressure PSIG	Discharge Pressure PSIG	Superheat	Subcooling	Water Temp Drop °F	Air Temp Rise °F DB
30	1.5	115-125	154-174	40-45	8-13	16.5-18.5	19-25	73-83	283-303	8-12	6-11	5.9-7.9	16-22
	2.25	115-125	141-161	40-45	6-11	12.1-14.1	20-26	75-85	285-305	8-12	6-11	4.2-6.2	17-23
	3	115-125	127-147	40-45	6-11	7.7-9.7	20-26	78-88	287-307	8-12	6-11	2.7-4.7	18-24
50	1.5	115-120	209-229	24-29	10-15	15.7-17.7	18-24	102-112	313-333	8-12	8-13	8.9-10.9	22-28
	2.25	115-120	195-215	24-29	8-13	11.6-13.6	18-24	106-116	314-334	8-12	8-13	6.7-8.7	23-29
	3	115-120	181-201	24-29	8-13	7.6-9.6	18-24	110-120	316-336	8-12	8-13	4.5-6.5	23-29
70	1.5	136-146	275-295	6-11	6-11	15.7-17.7	18-24	128-138	340-360	9-14	9-14	11.3-13.3	27-34
	2.25	136-146	261-281	6-11	5-10	11.6-13.6	18-24	134-144	342-362	9-14	9-14	8.5-10.5	28-35
	3	136-146	247-267	6-11	4-9	7.6-9.6	18-24	141-151	344-364	9-14	9-14	5.8-7.8	28-35
90	1.5	140-150	361-381	6-11	6-11	14.9-16.9	18-24	162-172	370-390	14-19	9-14	14.4-16.4	32-40
	2.25	140-150	347-367	6-11	5-10	11-13	18-24	166-176	376-396	15-20	9-14	10.8-12.8	34-42
	3	140-150	333-353	6-11	4-9	7.2-9.2	18-24	171-181	383-403	16-21	9-14	7.1-9.1	34-42
110	1.5	144-154	460-480	6-11	6-11	13.9-15.9	17-23						
	2.25	144-154	445-465	6-11	4-9	10.2-12.2	17-23						
	3	144-154	428-448	6-11	4-9	6.5-8.5	17-23						

030		Full Load Cooling - without HWG active						Full Load Heating - without HWG active					
Entering Water Temp °F	Water Flow GPM/ton	Suction Pressure PSIG	Discharge Pressure PSIG	Superheat	Subcooling	Water Temp Rise °F	Air Temp Drop °F DB	Suction Pressure PSIG	Discharge Pressure PSIG	Superheat	Subcooling	Water Temp Drop °F	Air Temp Rise °F DB
30	1.5	116-126	146-166	27-32	7-13	19.6-21.6	16-22	69-79	275-295	7-12	6-11	7.2-9.2	16-22
	2.25	115-125	138-158	27-32	6-11	14.3-16.3	17-23	73-83	277-297	7-12	6-11	5.4-7.4	17-23
	3	115-125	128-148	27-32	6-11	8-10	17-23	76-86	279-299	7-12	6-11	3.5-5.5	17-23
50	1.5	129-139	217-237	12-17	6-11	20.8-22.8	17-23	96-106	300-320	10-15	9-14	10.5-12.5	21-27
	2.25	128-138	203-223	12-17	5-10	15-17	18-24	100-110	304-324	10-15	9-14	7.6-9.6	22-28
	3	128-138	189-209	12-17	5-10	9.2-11.2	18-24	105-115	309-329	10-15	9-14	4.8-6.8	22-28
70	1.5	132-142	293-313	9-14	6-11	20.1-22.1	17-23	123-133	327-347	11-16	11-16	13.2-15.2	25-32
	2.25	131-141	274-294	9-14	5-10	14.4-16.4	18-24	129-139	333-353	11-16	11-16	9.8-11.8	26-33
	3	131-141	256-276	9-14	5-10	8.6-10.6	18-24	135-145	339-359	11-16	11-16	6.4-8.4	27-34
90	1.5	137-147	383-403	7-12	5-10	19.4-21.4	16-22	155-165	355-375	13-18	11-16	16.8-18.8	30-38
	2.25	137-147	362-382	7-12	5-10	13.8-15.8	16-22	162-172	362-382	14-19	11-16	12.7-14.7	31-39
	3	137-147	342-362	7-12	5-10	8.2-10.2	16-22	169-179	369-389	16-21	11-16	8.6-10.6	32-40
110	1.5	143-153	475-495	6-11	9-14	18.2-20.2	16-22						
	2.25	143-153	457-477	6-11	6-11	13-14	16-22						
	3	143-153	439-459	6-11	6-11	7.7-9.7	16-22						

036		Full Load Cooling - without HWG active						Full Load Heating - without HWG active					
Entering Water Temp °F	Water Flow GPM/ton	Suction Pressure PSIG	Discharge Pressure PSIG	Superheat	Subcooling	Water Temp Rise °F	Air Temp Drop °F DB	Suction Pressure PSIG	Discharge Pressure PSIG	Superheat	Subcooling	Water Temp Drop °F	Air Temp Rise °F DB
30	1.5	117-127	142-162	33-38	8-14	19.1-21.1	15-22	69-79	276-296	10-15	10-15	7.2-9.2	17-23
	2.25	116-126	134-154	33-38	7-12	13.8-15.8	15-22	73-83	278-298	10-15	10-15	5.3-7.3	18-24
	3	116-126	124-144	33-38	7-12	7.4-9.4	15-22	76-86	280-300	10-15	10-15	3.5-5.5	18-24
50	1.5	136-146	211-231	11-16	6-11	20.6-22.6	17-23	99-109	302-322	10-15	13-18	10.6-12.6	22-28
	2.25	136-146	197-217	11-16	5-10	14.8-16.8	17-23	103-113	306-326	10-15	13-18	7.7-9.7	23-29
	3	136-146	183-203	11-16	5-10	9-11	17-23	108-118	311-331	10-15	13-18	5-7	23-29
70	1.5	137-147	275-295	9-14	10-15	19-21	18-24	127-137	332-352	10-15	15-20	13.5-15.5	27-34
	2.25	137-147	260-280	9-14	9-14	13.8-15.8	19-25	133-143	338-358	10-15	15-20	10.1-12.1	28-35
	3	137-147	245-265	9-14	9-14	8-10	19-25	139-149	344-364	10-15	15-20	6.7-8.7	29-36
90	1.5	142-152	373-393	7-12	10-15	19.5-21.5	17-23	164-174	365-385	11-16	15-20	17.4-19.4	34-42
	2.25	142-152	352-372	8-13	6-11	13.9-15.9	17-23	172-182	372-392	11-16	15-20	13.2-15.2	35-43
	3	142-152	332-352	8-13	6-11	8.3-10.3	17-23	181-191	379-399	12-17	15-20	9-11	36-44
110	1.5	147-157	467-487	6-11	10-15	16.2-18.2	16-22						
	2.25	147-157	448-468	6-11	8-13	11.9-13.9	16-22						
	3	147-157	430-450	6-11	7-12	7.6-9.6	16-22						

UNIT OPERATING CONDITIONS

Table 12: GT-PG Series Typical Unit Operating Pressures and Temperatures: Continued

042		Full Load Cooling - without HWG active						Full Load Heating - without HWG active					
Entering Water Temp °F	Water Flow GPM/ton	Suction Pressure PSIG	Discharge Pressure PSIG	Superheat	Subcooling	Water Temp Rise °F	Air Temp Drop °F DB	Suction Pressure PSIG	Discharge Pressure PSIG	Superheat	Subcooling	Water Temp Drop °F	Air Temp Rise °F DB
30	1.5	114-124	170-190	27-32	10-15	17.2-19.2	17-23	69-79	286-306	5-10	5-10	4.5-6.5	16-22
	2.25	113-123	150-170	27-32	9-14	12.7-14.7	17-23	72-82	289-309	5-10	6-11	3.9-5.9	17-23
	3	113-123	131-151	27-32	7-12	8.2-10.2	17-23	75-85	292-312	6-11	6-11	3.2-5.2	18-24
50	1.5	130-140	226-246	10-15	6-11	17.8-19.8	20-26	100-110	315-335	7-12	6-11	9-11	22-28
	2.25	129-139	208-228	10-15	5-10	13.3-15.3	20-26	105-115	322-342	8-13	6-11	7-9	23-29
	3	129-139	190-210	10-15	4-9	8.8-10.8	20-26	110-120	330-350	10-15	7-12	5-7	24-30
70	1.5	132-142	290-310	6-11	6-11	17.3-19.3	19-25	131-141	347-367	11-16	6-11	13.4-15.4	29-35
	2.25	131-141	273-293	6-11	5-10	12.8-14.8	19-25	138-148	358-378	13-18	8-13	10-12	30-36
	3	131-141	255-275	6-11	4-9	8.3-10.3	19-25	145-155	369-389	16-21	9-14	6.9-8.9	31-37
90	1.5	136-146	370-390	6-11	6-11	16-18	17-23	175-185	393-413	19-24	7-12	17.6-19.6	36-42
	2.25	135-145	350-370	6-11	5-10	11.8-13.8	17-23	177-187	401-421	20-25	9-14	13.2-15.2	37-43
	3	135-145	330-350	6-11	4-9	7.6-9.6	17-23	180-190	409-429	22-27	12-17	8.7-10.7	38-44
110	1.5	143-153	469-489	6-11	6-11	14-16	16-22						
	2.25	142-152	448-468	6-11	5-10	11-13	16-22						
	3	141-151	427-447	6-11	4-9	7-9	16-22						

048		Full Load Cooling - without HWG active						Full Load Heating - without HWG active					
Entering Water Temp °F	Water Flow GPM/ton	Suction Pressure PSIG	Discharge Pressure PSIG	Superheat	Subcooling	Water Temp Rise °F	Air Temp Drop °F DB	Suction Pressure PSIG	Discharge Pressure PSIG	Superheat	Subcooling	Water Temp Drop °F	Air Temp Rise °F DB
30	1.5	108-118	180-200	27-32	12-17	19.8-21.8	19-25	65-75	293-313	7-12	9-14	8.2-10.2	17-23
	2.25	107-117	161-181	28-33	10-15	14.8-16.8	19-25	68-78	297-217	8-13	9-14	6.2-8.2	18-24
	3	107-117	142-162	29-34	9-14	9.8-11.8	19-25	72-82	301-321	9-14	9-14	4.2-6.2	19-25
50	1.5	123-133	236-256	16-21	8-13	20.2-22.2	21-27	92-102	321-341	10-15	11-16	11.6-13.6	23-29
	2.25	122-132	218-238	17-22	7-12	15.2-18.2	21-27	100-110	330-350	11-16	11-16	8.9-10.9	24-30
	3	122-132	200-220	17-22	6-11	10.2-12.2	21-27	108-118	340-360	12-17	11-16	6-8	26-32
70	1.5	130-140	305-325	10-15	8-13	20-22	20-26	122-132	353-373	12-17	11-16	15-17	29-35
	2.25	129-139	285-305	11-16	6-11	15-17	20-26	133-143	365-385	14-19	11-16	11.5-13.5	31-37
	3	129-139	265-285	11-16	5-10	10-12	20-26	144-154	378-398	16-21	11-16	8-10	33-39
90	1.5	133-143	390-410	8-13	8-13	19-21	19-25	166-176	397-417	16-21	9-14	19.5-21.5	37-43
	2.25	132-142	368-388	9-14	6-11	14-16	19-25	173-183	407-427	18-23	9-14	14.7-16.7	38-44
	3	132-142	345-365	9-14	5-10	9-11	19-25	181-191	417-437	19-24	10-15	9.9-11.9	40-46
110	1.5	141-151	497-517	6-11	8-13	18-20	18-24						
	2.25	140-150	472-492	7-12	6-11	13.5-15.5	18-24						
	3	140-150	447-467	8-13	5-10	8.7-10.7	18-24						

060		Full Load Cooling - without HWG active						Full Load Heating - without HWG active					
Entering Water Temp °F	Water Flow GPM/ton	Suction Pressure PSIG	Discharge Pressure PSIG	Superheat	Subcooling	Water Temp Rise °F	Air Temp Drop °F DB	Suction Pressure PSIG	Discharge Pressure PSIG	Superheat	Subcooling	Water Temp Drop °F	Air Temp Rise °F DB
30	1.5	98-108	160-180	40-45	12-17	20-22	19-25	62-72	276-296	6-11	6-11	8-10	17-23
	2.25	97-107	149-169	41-46	12-17	14.3-16.3	19-25	66-76	280-300	6-11	6-11	6-8	18-24
	3	96-106	137-157	42-48	11-16	8.5-10.5	20-26	70-80	284-304	7-12	6-11	4-6	19-25
50	1.5	118-128	225-245	36-41	11-16	21.2-23.2	19-25	88-98	306-326	10-15	8-13	11-13	23-29
	2.25	117-127	210-230	37-42	10-15	15.7-17.7	20-26	94-104	311-331	10-15	8-13	8.3-10.3	24-30
	3	115-125	195-215	38-43	9-14	10.2-12.2	21-27	100-110	317-337	11-16	9-14	5.5-7.5	25-31
70	1.5	135-145	300-320	12-17	9-14	20.3-22.3	21-27	112-122	333-353	12-17	10-15	14-16	28-34
	2.25	133-143	285-305	14-19	8-13	15-17	21-27	122-132	342-362	14-19	10-15	10.5-12.5	30-36
	3	132-142	270-290	16-21	7-12	10-12	22-28	130-140	351-371	15-20	11-16	7.3-9.3	32-38
90	1.5	139-149	390-410	8-13	7-12	19.3-21.3	20-26	147-157	369-389	15-20	10-15	17.7-19.7	36-42
	2.25	138-148	370-390	8-13	6-11	14.3-16.3	21-27	154-164	377-397	18-23	10-15	13.4-15.4	37-43
	3	138-148	350-370	8-13	6-11	9.3-11.3	21-27	160-170	385-405	19-24	11-16	9-11	38-44
110	1.5	144-154	488-508	8-13	8-13	18.4-20.4	21-27						
	2.25	143-153	468-488	7-12	6-11	13.6-15.6	21-27						
	3	142-152	448-468	7-12	5-10	8.8-10.8	21-27						

UNIT OPERATING CONDITIONS

Table 12: GT-PG Series Typical Unit Operating Pressures and Temperatures: Continued

070		Full Load Cooling - without HWG active						Full Load Heating - without HWG active					
Entering Water Temp °F	Water Flow GPM/ton	Suction Pressure PSIG	Discharge Pressure PSIG	Superheat	Subcooling	Water Temp Rise °F	Air Temp Drop °F DB	Suction Pressure PSIG	Discharge Pressure PSIG	Superheat	Subcooling	Water Temp Drop °F	Air Temp Rise °F DB
30	1.5	110-120	177-197	36-41	15-20	20.2-22.2	21-27	61-71	290-310	12-18	9-14	8-10	19-25
	2.25	109-119	162-182	37-42	13-18	15-17	21-27	65-75	292-312	12-18	10-15	6-8	20-26
	3	107-117	147-167	38-43	11-16	9.7-11.7	22-28	68-78	296-316	12-18	10-15	4-6	21-27
50	1.5	128-138	246-266	18-23	11-16	21-23	22-28	88-98	320-340	11-17	13-18	11.7-13.7	26-32
	2.25	128-138	228-248	19-24	9-14	15.6-17.6	23-29	96-106	330-350	11-17	11-16	9-11	27-33
	3	127-137	210-230	20-25	6-11	10.2-12.2	24-30	105-115	338-358	11-17	9-14	6-8	29-35
70	1.5	134-144	305-325	9-14	11-16	20.8-22.8	23-29	118-128	355-375	10-16	14-19	15.2-17.2	33-39
	2.25	133-143	289-309	9-14	9-14	15.4-17.4	23-29	130-140	368-388	12-18	13-18	11.7-13.7	35-41
	3	131-141	273-293	9-14	6-11	10-12	23-29	141-151	380-400	15-21	11-16	8-10	37-43
90	1.5	140-150	390-410	10-15	11-16	19.6-21.6	22-28	158-168	401-421	9-15	13-18	19.5-21.5	41-47
	2.25	139-149	373-393	10-15	9-14	14.5-16.5	22-28	168-178	412-432	10-16	12-17	14.8-16.8	43-49
	3	138-148	355-375	10-15	6-11	9.3-11.3	22-28	178-188	423-443	12-18	12-17	10-12	45-51
110	1.5	144-154	488-508	10-15	9-14	18.4-20.4	20-27						
	2.25	143-153	468-488	10-15	6-11	13.6-15.6	20-27						
	3	142-152	448-468	9-14	5-10	8.8-10.8	20-27						

Table 13: GT-G Series Typical Unit Operating Pressures and Temperatures

Entering Water Temp °F	Water Flow GPM/ton	Full Load Cooling - without HWG active						Full Load Heating - without HWG active					
		Suction Pressure PSIG	Discharge Pressure PSIG	Superheat	Subcooling	Water Temp Rise °F	Air Temp Drop °F DB	Suction Pressure PSIG	Discharge Pressure PSIG	Superheat	Subcooling	Water Temp Drop °F	Air Temp Rise °F DB
30	1.5	75-85	90-105	25-40	12-20	21-24	21-26	34-39	167-186	12-16	1-4	7.6-8.4	14-20
	2.25	74-84	80-95	25-40	11-18	13-16	21-26	37-43	172-191	12-16	1-4	4.8-5.6	16-22
	3	73-83	70-85	25-40	10-16	10-16	21-26	40-46	177-196	12-16	1-4	3.4-4.2	16-22
50	1.5	75-85	125-155	12-20	10-18	20-23	20-25	50-60	180-210	10-17	1-5	10.8-11.9	23-29
	2.25	74-84	120-142	12-20	9-16	12-15	20-25	53-62	185-215	10-17	1-5	6.7-8.1	24-30
	3	73-83	115-138	12-20	8-14	8-12	20-25	55-65	190-220	10-17	1-5	5.1-5.9	28-31
70	1.5	75-85	179-198	9-16	8-15	19-22	19-24	71-82	205-230	14-19	1-5	14.0-15.2	28-34
	2.25	74-84	168-186	9-16	8-14	12-17	19-24	73-85	210-238	14-19	1-5	9.0-10.2	30-37
	3	73-83	158-175	9-16	8-12	7-12	19-24	76-88	215-242	14-19	1-5	6.7-7.9	31-38
90	1.5	75-85	229-251	9-17	8-15	18-21	17-23	85-95	220-260	18-28	2-5	14.4-16.6	32-39
	2.25	74-84	218-241	9-17	8-14	10-14	17-23	90-100	225-265	18-28	2-5	10.8-12.4	33-41
	3	73-83	208-230	9-17	8-12	6-11	17-23	95-105	230-270	18-28	2-5	7.2-8.3	35-42
110	1.5	77-87	280-320	8-15	10-25	17-20	15-20						
	2.25	76-86	270-310	8-15	10-24	9-13	15-20						
	3	75-85	260-300	8-15	10-22	5-10	15-20						

PREVENTIVE MAINTENANCE

Water Coil Maintenance

(Direct ground water applications only) - If the system is installed in an area with a known high mineral content (125 P.P.M. or greater) in the water, it is best to establish a periodic maintenance schedule with the owner so the coil can be checked regularly. Consult the well water applications section of this manual for a more detailed water coil material selection. Should periodic coil cleaning be necessary, use standard coil cleaning procedures, which are compatible with the heat exchanger material and copper water lines. Generally, the more water flowing through the unit, the less chance for scaling. Therefore, 1.5 gpm per ton [2.0 l/m per kW] is recommended as a minimum flow. Minimum flow rate for entering water temperatures below 50°F [10°C] is 2.0 gpm per ton [2.6 l/m per kW].

Water Coil Maintenance

(All other water loop applications)
Generally water coil maintenance is not needed for closed loop systems. However, if the piping is known to have high dirt or debris content, it is best to establish a periodic maintenance schedule with the owner so the water coil can be checked regularly. Dirty installations are typically the result of deterioration of iron or galvanized piping or components in the system. Open cooling towers requiring heavy chemical treatment and mineral buildup through water use can also contribute to higher maintenance. Should periodic coil cleaning be necessary, use standard coil cleaning procedures, which are compatible with both the heat exchanger material and copper water lines. Generally, the more water flowing through the unit, the less chance for scaling. However, flow rates over 3 gpm per ton (3.9 l/m per kW) can produce water (or debris) velocities that can erode the heat exchanger wall and ultimately produce leaks.

Hot Water Generator Coils

See water coil maintenance for ground water units. If the potable water is hard or not chemically softened, the high temperatures of the desuperheater will tend to scale even quicker than the water coil and may need more frequent inspections. In areas with extremely hard water, a HWG is not recommended.

Filters

Filters must be clean to obtain maximum performance. Filters should be inspected every month under normal operating conditions and be replaced when necessary. Units should never be operated without a filter.

Washable, high efficiency, electrostatic filters, when dirty, can exhibit a very high pressure drop for the fan motor and reduce air flow, resulting in poor performance. It is especially important to provide consistent washing of these filters (in the opposite direction of the normal air flow) once per month using a high pressure wash similar to those found at self-serve car washes.

Condensate Drain

In areas where airborne bacteria may produce a “slimy” substance in the drain pan, it may be necessary to treat the drain pan chemically with an algicide approximately every three months to minimize the problem. The condensate pan may also need to be cleaned periodically to insure indoor air quality. The condensate drain can pick up lint and dirt, especially with dirty filters. Inspect the drain twice a year to avoid the possibility of plugging and eventual overflow.

Compressor

Conduct annual amperage checks to insure that amp draw is no more than 10% greater than indicated on the serial plate data.

Fan Motors

All units have lubricated fan motors. Fan motors should never be lubricated unless obvious, dry operation is suspected. Periodic maintenance oiling is not recommended, as it will result in dirt accumulating in the excess oil and cause eventual motor failure. Conduct annual dry operation check and amperage check to insure amp draw is no more than 10% greater than indicated on serial plate data.

Air Coil

The air coil must be cleaned to obtain maximum performance. Check once a year under normal operating conditions and, if dirty, brush or vacuum clean. Care must be taken not to damage the aluminum fins while cleaning. CAUTION: Fin edges are sharp.

Cabinet

Do not allow water to stay in contact with the cabinet for long periods of time to prevent corrosion of the cabinet sheet metal. Generally, vertical cabinets are set up from the floor a few inches [7 - 8 cm] to prevent water from entering the cabinet. The cabinet can be cleaned using a mild detergent.

Refrigerant System

To maintain sealed circuit integrity, do not install service gauges unless unit operation appears abnormal. Reference the operating charts for pressures and temperatures. Verify that air and water flow rates are at proper levels before servicing the refrigerant circuit.

TROUBLESHOOTING

General

If operational difficulties are encountered, perform the preliminary checks below before referring to the troubleshooting charts.

- Verify that the unit is receiving electrical supply power.
- Make sure the fuses in the fused disconnect switches are intact.

After completing the preliminary checks described above, inspect for other obvious problems such as leaking connections, broken or disconnected wires, etc. If everything appears to be in order, but the unit still fails to operate properly, refer to the “CXM Troubleshooting Process Flowchart” or “Functional Troubleshooting Chart.”

CXM Board

CXM board troubleshooting in general is best summarized as simply verifying inputs and outputs. After inputs and outputs have been verified, board operation is confirmed and the problem must be elsewhere. Below are some general guidelines for troubleshooting the CXM control.

Field Inputs

All inputs are 24VAC from the thermostat and can be verified using a volt meter between C and Y, G, O, W. 24VAC will be present at the terminal (for example, between “Y” and “C”) if the thermostat is sending an input to the CXM board.

Sensor Inputs

All sensor inputs are ‘paired wires’ connecting each component to the board. Therefore, continuity on pressure switches, for example can be checked at the board connector.

The thermistor resistance should be measured with the connector removed so that only the impedance of the thermistor is measured. If desired, this reading can be compared to the thermistor resistance chart shown in the CXM/DXM AOM manual. An ice bath can be used to check calibration of the thermistor.

Outputs

The compressor relay is 24VAC and can be verified using a voltmeter. The fan signal is passed through the board to the external fan relay (units with PSC motors only). The alarm relay can either be 24VAC as shipped or dry contacts for use with DDC controls by clipping the JW1 jumper. Electric heat outputs are 24VDC “ground sinking” and require a volt meter set for DC to verify operation. The terminal marked “24VDC” is the 24VDC supply to the electric heat board; terminal “EH1” is stage 1 electric heat; terminal “EH2” is stage 2 electric heat. When electric heat is energized (thermostat is sending a “W” input to the CXM controller), there will be 24VDC between terminal “24VDC” and “EH1” (stage 1 electric heat) and/or “EH2” (stage 2 electric heat). A reading of 0VDC between “24VDC” and “EH1” or “EH2” will indicate that the CXM board is NOT sending an output signal to the electric heat board.

Test Mode

Test mode can be entered for 20 minutes by shorting the test pins. The CXM board will automatically exit test mode after 20 minutes.

CXM Troubleshooting Process Flowchart / Functional Troubleshooting Chart

The “CXM Troubleshooting Process Flowchart” is a quick overview of how to start diagnosing a suspected problem, using the fault recognition features of the CXM board. The “Functional Troubleshooting Chart” on the following page is a more comprehensive method for identifying a number of malfunctions that may occur, and is not limited to just the CXM controls. Within the chart are five columns:

- The “Fault” column describes the symptoms.
- Columns 2 and 3 identify in which mode the fault is likely to occur, heating or cooling.
- The “Possible Cause column” identifies the most likely sources of the problem.
- The “Solution” column describes what should be done to correct the problem.

⚠ WARNING! ⚠

WARNING! HAZARDOUS VOLTAGE!
DISCONNECT ALL ELECTRIC POWER
INCLUDING REMOTE DISCONNECTS
BEFORE SERVICING.

Failure to disconnect power before servicing
can cause severe personal injury or death.

CXM PROCESS FLOW CHART

⚠ WARNING! ⚠

WARNING! HAZARDOUS VOLTAGE!
 DISCONNECT ALL ELECTRIC POWER
 INCLUDING REMOTE DISCONNECTS
 BEFORE SERVICING.
 Failure to disconnect power before servicing
 can cause severe personal injury or death.

CXM Functional Troubleshooting Chart

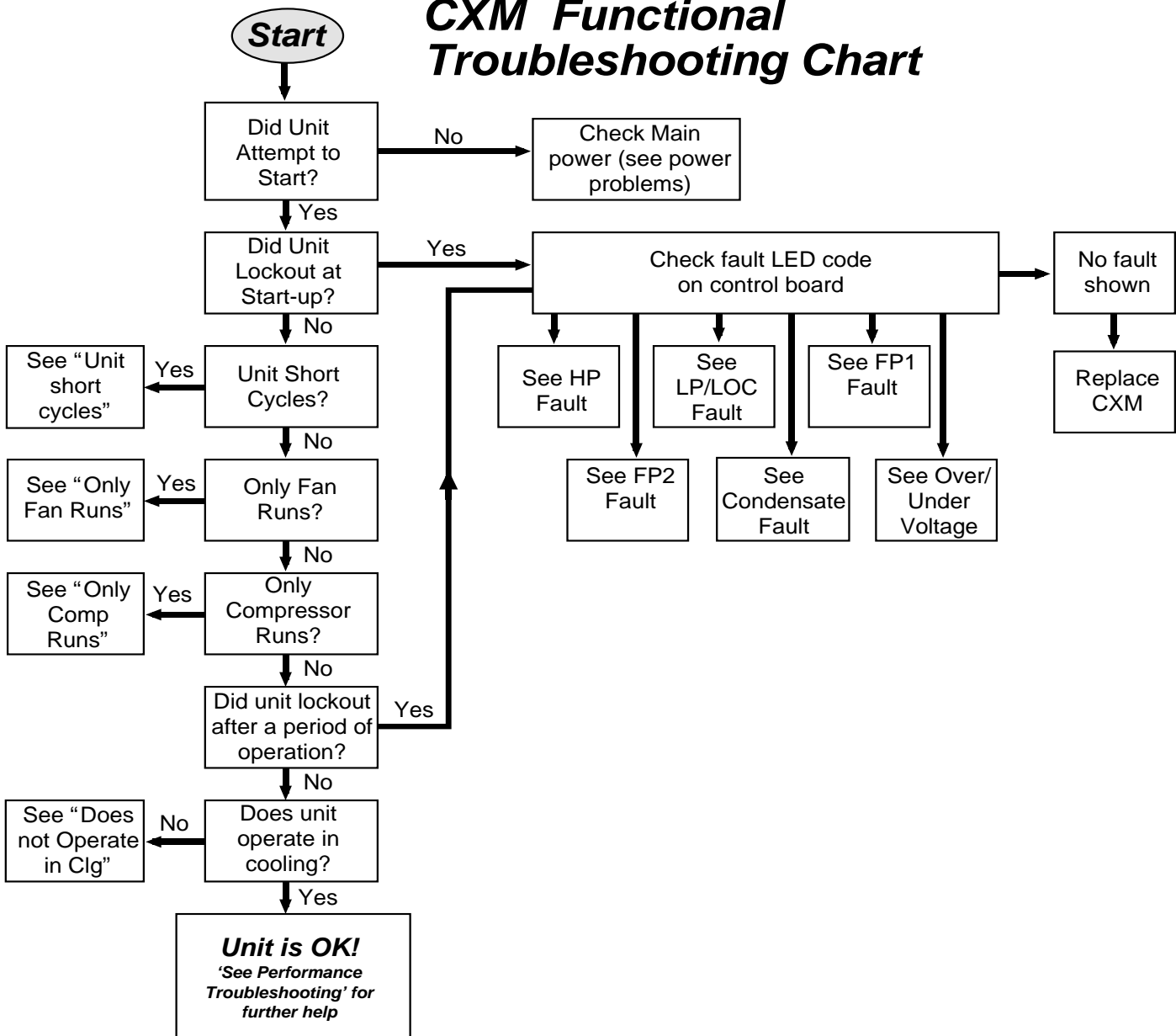

FUNCTIONAL TROUBLESHOOTING

Fault	Htg	Clg	Possible Cause	Solution
Main power Problems	X	X	Green Status LED Off	Check Line Voltage circuit breaker and disconnect Check for line voltage between L1 and L2 on the contactor Check for 24VAC between R and C on CXM/DXM Check primary/secondary voltage on transformer
		X	Reduced or no water flow in cooling	Check pump operation or valve operation/setting Check water flow adjust to proper flow rate
		X	Water Temperature out of range in cooling	Bring water temp within design parameters
	X		Reduced or no Air flow in heating	Check for dirty air filter and clean or replace Check fan motor operation and airflow restrictions Dirty Air Coil- construction dust etc. Too high of external static. Check static vs blower table
	X	Air Temperature out of range in heating	Bring return air temp within design parameters	
	X	X	Overcharged with refrigerant	Check superheat/subcooling vs typical operating condition table
	X	X	Bad HP Switch	Check switch continuity and operation. Replace
LP/LOC Fault-Code 3 Low Pressure/Loss of Charge	X	X	Insufficient charge	Check for refrigerant leaks
	X		Compressor pump down at start-up	Check charge and start-up water flow
FP1 Fault - Code 4 Water Coil low temperature limit	X		Reduced or no water flow in heating	Check pump operation or water valve operation/setting Plugged strainer or filter. Clean or replace. Check water flow adjust to proper flow rate
	X		Inadequate anti-freeze level	Check antifreeze density with hydrometer
	X		Improper temperature limit setting (30°F vs 10°F [-1°C vs -12°C])	Clip JW3 jumper for antifreeze (10°F [-12°C]) use
	X		Water Temperature out of range	Bring water temp within design parameters
	X	X	Bad thermistor	Check temp and impedance correlation per chart
FP2 fault - Code 5 Air Coil low temperature limit		X	Reduced or no Air flow in cooling	Check for dirty air filter and clean or replace Check fan motor operation and airflow restrictions Too high of external static. Check static vs blower table
		X	Air Temperature out of range	Too much cold vent air? Bring entering air temp within design parameters
		X	Improper temperature limit setting (30°F vs 10°F [-1°C vs -12°C])	Normal airside applications will require 30°F [-1°C] only
	X	X	Bad thermistor	Check temp and impedance correlation per chart
Condensate Fault-Code 6	X	X	Blocked Drain	Check for blockage and clean drain
	X	X	Improper trap	Check trap dimensions and location ahead of vent
		X	Poor Drainage	Check for piping slope away from unit Check slope of unit toward outlet Poor venting. Check vent location
		X	Moisture on sensor	Check for moisture shorting to air coil
Over/Under Voltage-Code 7 (Auto resetting)	X	X	Under Voltage	Check power supply and 24VAC voltage before and during operation. Check power supply wire size Check compressor starting. Need hard start kit? Check 24VAC and unit transformer tap for correct power supply voltage
	X	X	Over Voltage	Check power supply voltage and 24VAC before and during operation. Check 24VAC and unit transformer tap for correct power supply voltage
Unit Performance Sentinel-Code 8	X		Heating mode FP2>125°F [52°C]	Check for poor air flow or overcharged unit.
		X	Cooling Mode FP1>125°F [52°C] OR FP2< 40°F [4°C]	Check for poor water flow, or air flow
No Fault Code Shown	X	X	No compressor operation	See "Only fan operates"
	X	X	Compressor Overload	Check and Replace if necessary
	X	X	Control board	Reset power and check operation
Unit Short Cycles	X	X	Dirty Air Filter	Check and Clean air filter
	X	X	Unit in "Test Mode"	Reset power or wait 20 minutes for auto exit.
	X	X	Unit selection	Unit may be oversized for space. Check sizing for actual load of space.
	X	X	Compressor Overload	Check and Replace if necessary
Only Fan Runs	X	X	Thermostat position	Insure thermostat set for heating or cooling operation
	X	X	Unit locked out	Check for lockout codes. Reset power.
	X	X	Compressor Overload	Check compressor overload. Replace if necessary.
	X	X	Thermostat wiring	Check thermostat wiring at heat pump. Jumper Y and R for compressor operation in test mode.

FUNCTIONAL TROUBLESHOOTING

Only Compressor Runs	X	X	Thermostat wiring	Check G wiring at heat pump. Jumper G and R for fan operation.
	X	X	Fan motor relay	Jumper G and R for fan operation. Check for Line voltage across BR contacts. Check fan power enable relay operation (if present)
	X	X	Fan motor	Check for line voltage at motor. Check capacitor
	X	X	Thermostat wiring	Check thermostat wiring at heat pump. Jumper Y and R for compressor operation in test mode.
Unit Doesn't Operate in Cooling		X	Reversing Valve	Set for cooling demand and check 24VAC on RV coil and at CXM/DXM board. If RV is stuck, run high pressure up by reducing water flow and while operating engage and disengage RV coil voltage to push valve.
		X	Thermostat setup	Check for 'O' RV setup not 'B'
		X	Thermostat wiring	Check O wiring at heat pump. Jumper O and R for RV coil 'Click'.
		X	Thermostat wiring	Put thermostat in cooling mode. Check for 24VAC on O (check between C and O); check for 24VAC on W (check between W and C). There should be voltage on O, but not on W. If voltage is present on W, thermostat may be bad or wired incorrectly.

PERFORMANCE TROUBLESHOOTING

Performance Troubleshooting	Htg	Clg	Possible Cause	Solution
Insufficient capacity/ Not cooling or heating properly	X	X	Dirty Filter	Replace or clean
	X		Reduced or no Air flow in heating	Check for dirty air filter and clean or replace Check fan motor operation and airflow restrictions Too high of external static. Check static vs blower table
		X	Reduced or no Air flow in cooling	Check for dirty air filter and clean or replace Check fan motor operation and airflow restrictions Too high of external static. Check static vs blower table
	X	X	Leaky duct work	Check supply and return air temperatures at the unit and at distant duct registers if significantly different, duct leaks are present
	X	X	Low refrigerant charge	Check superheat and subcooling per chart
	X	X	Restricted metering device	Check superheat and subcooling per chart. Replace.
		X	Defective Reversing Valve	Perform RV touch test
	X	X	Thermostat improperly located	Check location and for air drafts behind stat
	X	X	Unit undersized	Recheck loads & sizing check sensible clg load and heat pump capacity
	X	X	Scaling in water heat exchanger	Perform Scaling check and clean if necessary
	X	X	Inlet Water too Hot or Cold	Check load, loop sizing, loop backfill, ground moisture.
High Head Pressure	X		Reduced or no Air flow in heating	Check for dirty air filter and clean or replace Check fan motor operation and airflow restrictions Too high of external static. Check static vs blower table
		X	Reduced or no water flow in cooling	Check pump operation or valve operation/setting Check water flow adjust to proper flow rate
		X	Inlet Water too Hot	Check load, loop sizing, loop backfill, ground moisture.
	X		Air Temperature out of range in heating	Bring return air temp within design parameters
		X	Scaling in water heat exchanger	Perform Scaling check and clean if necessary
	X	X	Unit Overcharged	Check superheat and subcooling. Reweigh in charge
	X	X	Non-condensables insystem	Vacuum system and reweigh in charge
	X	X	Restricted metering device	Check superheat and subcooling per chart. Replace.
Low Suction Pressure	X		Reduced water flow in heating	Check pump operation or water valve operation/setting Plugged strainer or filter. Clean or replace. Check water flow adjust to proper flow rate
	X		Water Temperature out of range	Bring water temp within design parameters
		X	Reduced Air flow in cooling	Check for dirty air filter and clean or replace Check fan motor operation and airflow restrictions Too high of external static. Check static vs blower table
		X	Air Temperature out of range	Too much cold vent air? Bring entering air temp within design parameters
	X	X	Insufficient charge	Check for refrigerant leaks
Low discharge air temperature in heating	X		Too high of air flow	Check fan motor speed selection and airflow chart
	X		Poor Performance	See 'Insufficient Capacity'
High humidity		X	Too high of air flow	Check fan motor speed selection and airflow chart
		X	Unit oversized	Recheck loads & sizing check sensible clg load and heat pump capacity

TROUBLESHOOTING FORM

HEATING CYCLE ANALYSIS -

Refrigerant Type: _____

R410A

R22

R407C

Voltage: _____

Comp Amps: _____

Total Amps: _____

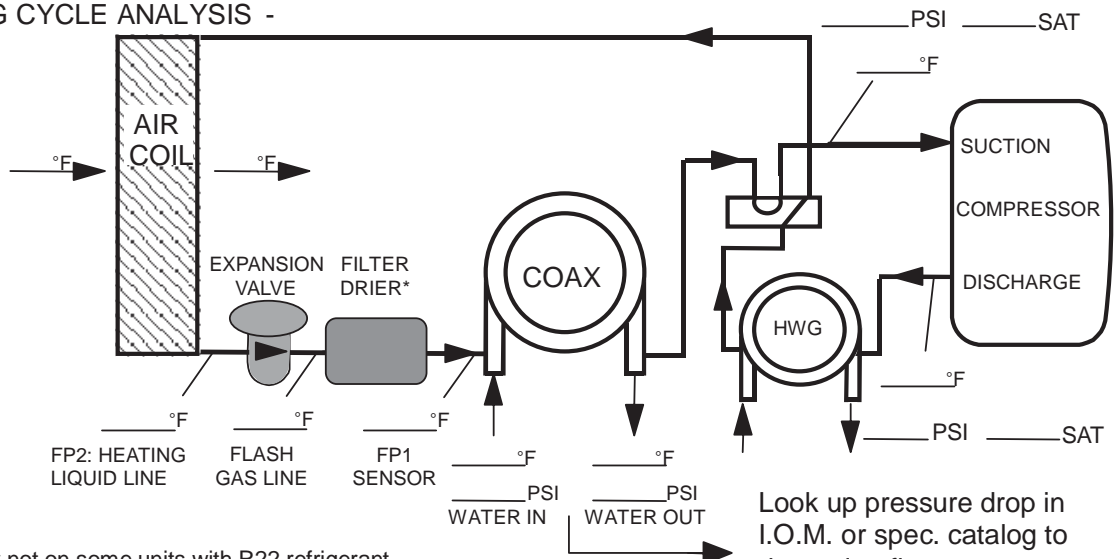

*Filter drier not on some units with R22 refrigerant.

COOLING CYCLE ANALYSIS -

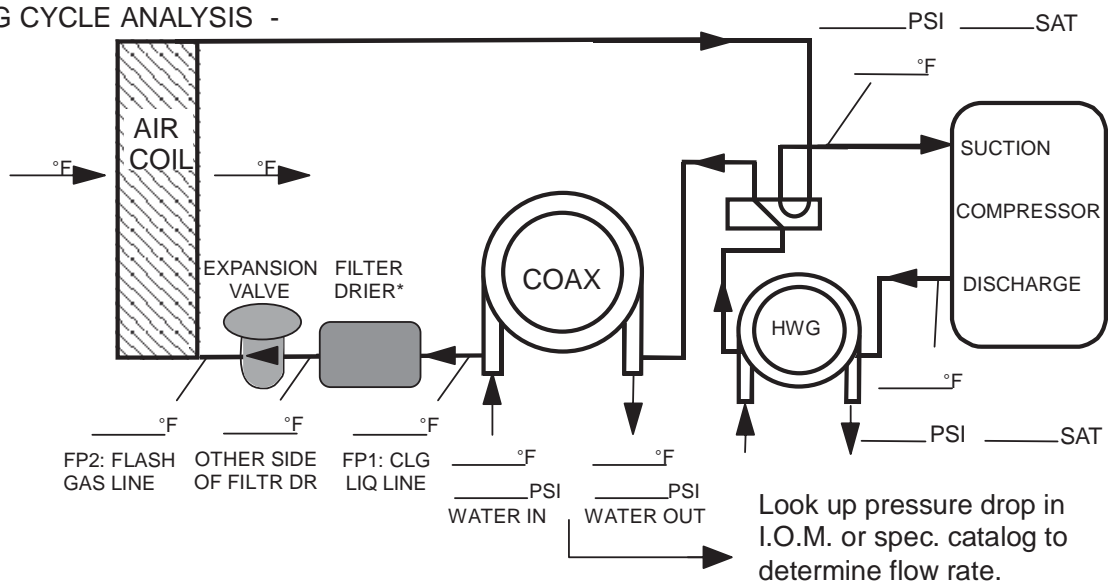

Heat of Extraction (Absorption) or Heat of Rejection =

_____ flow rate (gpm) x _____ temp.diff. (deg. F) x _____ fluid factor[†] = _____ (Btu/hr)

Superheat = Suction temperature - suction saturation temp. = _____ (deg F)

Subcooling = Discharge saturation temp. - liquid line temp. = _____ (deg F)

Note: Never connect refrigerant gauges during startup procedures. Conduct water-side analysis using P/T ports to determine water flow and temperature difference. If water-side analysis shows poor performance, refrigerant troubleshooting may be required. Connect refrigerant gauges as a last resort.

NOTES

WARRANTY



CARRIER CORPORATION LIMITED EXPRESS WARRANTY/LIMITATION OF REMEDIES AND LIABILITY FOR RESIDENTIAL GEOTHERMAL PRODUCTS

It is expressly understood that unless a statement is specifically identified as a warranty, statements made by Carrier Corporation, a Delaware corporation, ("Carrier") or its representatives, relating to Carrier's products, whether oral, written or contained in any sales literature, catalog or agreement, are not express warranties and do not form a part of the basis of the bargain, but are merely Carrier's opinion or commendation of Carrier's products.
EXCEPT AS SPECIFICALLY SET FORTH HEREIN, THERE IS NO EXPRESS WARRANTY AS TO ANY OF CARRIER'S PRODUCTS. CARRIER MAKES NO WARRANTY AGAINST LATENT DEFECTS. CARRIER MAKES NO WARRANTY OF MERCHANTABILITY OF THE GOODS OR OF THE FITNESS OF THE GOODS FOR ANY PARTICULAR PURPOSE.

GRANT OF LIMITED EXPRESS WARRANTY

Carrier warrants its residential geothermal products, purchased and retained in the United States of America and Canada, to be free from defects in material and workmanship under normal use and maintenance as follows: (1) 50YD, 50YE, 50YC and 38WQS heat pump units built or sold by Carrier ("Carrier Geothermal Units") for five (5) years from the Warranty Inception Date (as defined below); (2) Auxiliary electric heaters and geothermal pumping modules built or sold by Carrier, when installed with Carrier Geothermal Units, for five (5) years from the Warranty Inception Date (as defined below); (3) Sealed refrigerant circuit components of Carrier Geothermal Units (which components only include the compressor, refrigerant to air/water heat exchangers, reversing valve body and refrigerant metering device) for ten (10) years from the Warranty Inception Date (as defined below). The "Warranty Inception Date" shall be the date of original unit installation, or six (6) months from date of unit shipment from Carrier, whichever comes first.

To make a claim under this warranty, parts must be returned to Carrier in Oklahoma City, Oklahoma, freight prepaid, no later than ninety (90) days after the date of the failure of the part; if Carrier determines the part to be defective and within Carrier's Limited Express Warranty, Carrier shall, when such part has been either replaced or repaired, return such to a factory recognized distributor, dealer or service organization, F.O.B. Carrier, Oklahoma City, Oklahoma, freight prepaid. The warranty on any part repaired or replaced under warranty expires at the end of the original warranty period.

This warranty does not cover and does not apply to: (1) Air filters, fuses, refrigerant, fluids, oil; (2) Products relocated after initial installation; (3) Any portion or component of any system that is not supplied by Carrier, regardless of the cause of the failure or inadequate installation, maintenance, repair, wiring or voltage conditions; (4) Products on which the unit identification tags or labels have been removed or defaced; (5) Products on which payment to Carrier, or to the owner's seller, is in default; (6) Products subjected to improper or inadequate installation, liquid temperatures or flow rates; or opening of the refrigerant circuit by unqualified personnel; (8) Mold, fungus or bacteria damages; (9) Corrosion or abrasion of the product; (10) Products supplied by others; (11) Products which have been operated in a manner contrary to Carrier's printed instructions; (12) Products which have insufficient performance as a result of improper application, installation, or use of Carrier's products; or (13) Electricity or fuel costs, or any increases or unrealized savings in same, for any reason whatsoever.

Carrier is not responsible for: (1) The costs of any fluids, refrigerant or system components supplied by others, or associated labor to repair or replace the same, which is incurred as a result of a defective part covered by Carrier's Limited Express Warranty; (2) The costs of labor, refrigerant, materials or service incurred in diagnosis and removal of the defective part, or in obtaining and replacing the new or repaired part; (3) Transportation costs of the defective part from the installation site to Carrier, or of the return of that part if not covered by Carrier's Limited Express Warranty; or (4) The costs of normal maintenance.

This Limited Express Warranty applies to Carrier Residential Geothermal products manufactured on or after June 9, 2003 (Carrier Geothermal Units with serial numbers beginning with 2403 or later), and is not retroactive to any products produced prior to June 9, 2003 (Carrier Geothermal Units with serial numbers beginning with 2303 and earlier).

Limitation: This Limited Express Warranty is given in lieu of all other warranties. If, notwithstanding the disclaimers contained herein, it is determined that other warranties exist, any such express warranty, including without limitation any express warranties or any implied warranties of fitness for particular purpose and merchantability, shall be limited to the duration of the Limited Express Warranty.

LIMITATION OF REMEDIES

In the event of a breach of the Limited Express Warranty, Carrier will only be obligated at Carrier's option to repair the failed part or unit, or to furnish a new or rebuilt part or unit in exchange for the failed part or unit which has failed. If after written notice to Carrier's factory in Oklahoma City, Oklahoma of each defect, malfunction or other failure, and a reasonable number of attempts by Carrier to correct the defect, malfunction or other failure, and the remedy fails of its essential purpose, Carrier shall refund the purchase price paid to Carrier in exchange for the return of the sold goods(s). Said refund shall be the maximum liability of Carrier. **THIS REMEDY IS THE SOLE AND EXCLUSIVE REMEDY OF THE BUYER OR PURCHASER AGAINST CARRIER FOR BREACH OF CONTRACT, FOR THE BREACH OF ANY WARRANTY OR FOR CARRIER'S NEGLIGENCE OR IN STRICT LIABILITY.**

LIMITATION OF LIABILITY

Carrier shall have no liability for any damages if Carrier's performance is delayed for any reason or is prevented to any extent by any event such as, but not limited to: any war, civil unrest, government restrictions or restraints, strikes, or work stoppages, fire, flood, accident, shortages of transportation, fuel, material, or labor, acts of God or any other reason beyond the sole control of Carrier. **CARRIER EXPRESSLY DISCLAIMS AND EXCLUDES ANY LIABILITY FOR CONSEQUENTIAL OR INCIDENTAL DAMAGE IN CONTRACT, FOR BREACH OF ANY EXPRESS OR IMPLIED WARRANTY, OR IN TORT, WHETHER FOR CARRIER'S NEGLIGENCE OR AS STRICT LIABILITY.**

OBTAINING WARRANTY PERFORMANCE

Normally, the dealer or service organization who installed the products will provide warranty performance for the owner. Should the installer be unavailable, contact any Carrier recognized distributor, dealer or service organization. If assistance is required in obtaining warranty performance, write or call:

Carrier Corporation • Customer Service • 7300 SW 44th Street • Oklahoma City, Oklahoma 73179 • (405) 745-2920

NOTE: Some states or Canadian provinces do not allow limitations on how long an implied warranty lasts, or the limitation or exclusions of consequential or incidental damages, so the foregoing exclusions and limitations may not apply to you. This warranty gives you specific legal rights, and you may also have other rights which vary from state to state and from Canadian province to Canadian province.

Please refer to the Carrier Installation, Operation and Maintenance Manual for operating and maintenance instructions.

Rev.: 04/06
Part No.: CA185

IOM Revision Log:

Date	Page #	Description
08/22/06	44 & 45	Added Wiring Diagrams for GT-PX & GT-PG Units with Whole House Dehumidification Option
08/22/06	36	Updated All Unit Blower Performance Data
08/22/06	28	Updated All Unit Electrical Data
08/22/06	4	Updated All Unit Physical Data
08/22/06	2	Added Whole House Dehumidification Option to Decoder
08/22/06	All	Various Formatting Updates
07/19/05	All	First Published



97B0046N01

7300 S.W. 44th Street
 Oklahoma City, OK 73179
 Phone: 405-745-2920
 Fax: 405-745-6620

The Manufacturer works continually to improve its products. As a result, the design and specifications of each product at the time for order may be changed without notice and may not be as described herein. Please contact the Manufacturer's Customer Service Department at 1-405-745-6000 for specific information on the current design and specifications. Statements and other information contained herein are not express warranties and do not form the basis of any bargain between the parties, but are merely Manufacturer's opinion or commendation of its products.

The management system governing the manufacture of Manufacturer's products is ISO 9001:2000 certified.