

GT-PB Series (50YFV, 50YFH Models)

Installation, Operation and Maintenance Instructions



Residential Digital Horizontal & Vertical Packaged
Geothermal Heat Pumps

97B0046N05
Created: 1 Oct., 2012

Table of Contents

Model Nomenclature	3	Thermostat Wiring	29
General Information	4	Wiring Diagrams	30-33
Pre-Installation	4	ECM Blower Control	34
Vertical Installation	5	Blower Data	35
Horizontal Installation	6-8	DXM2 Controls	36-37
Condensate and Water Connections	9	Low Water Temperature Cutout Selection	37
Integrated Variable-Speed Water Flow Control Heat Pump Applications Overview	10	Unit Commissioning and Operating Conditions	38
Closed Loop Applications with Internal Flow Control	11	Unit and System Checkout	39
Flushing the Earth Loop	12-14	Unit Start-Up Procedure	39-41
Multiple Unit Piping and Flushing	15-17	Unit Operating Conditions	41-43
Ground Loop Applications	18-19	Performance Data (Full Load)	44-49
Closed Loop - External Central Pumping Applications	20	Preventive Maintenance	50
Open Loop or Ground Water Systems	21-22	Troubleshooting	51-52
Water Quality Requirements	23	DXM2 Troubleshooting	53
Hot Water Generator	24-26	Functional & Performance Troubleshooting	54-57
Electrical - Line Voltage	27	Troubleshooting Form	58
Electrical - Low Voltage Wiring	28	Warranty	59
		Revision History	60

This page was intentionally left blank.

Model Nomenclature: General Overview

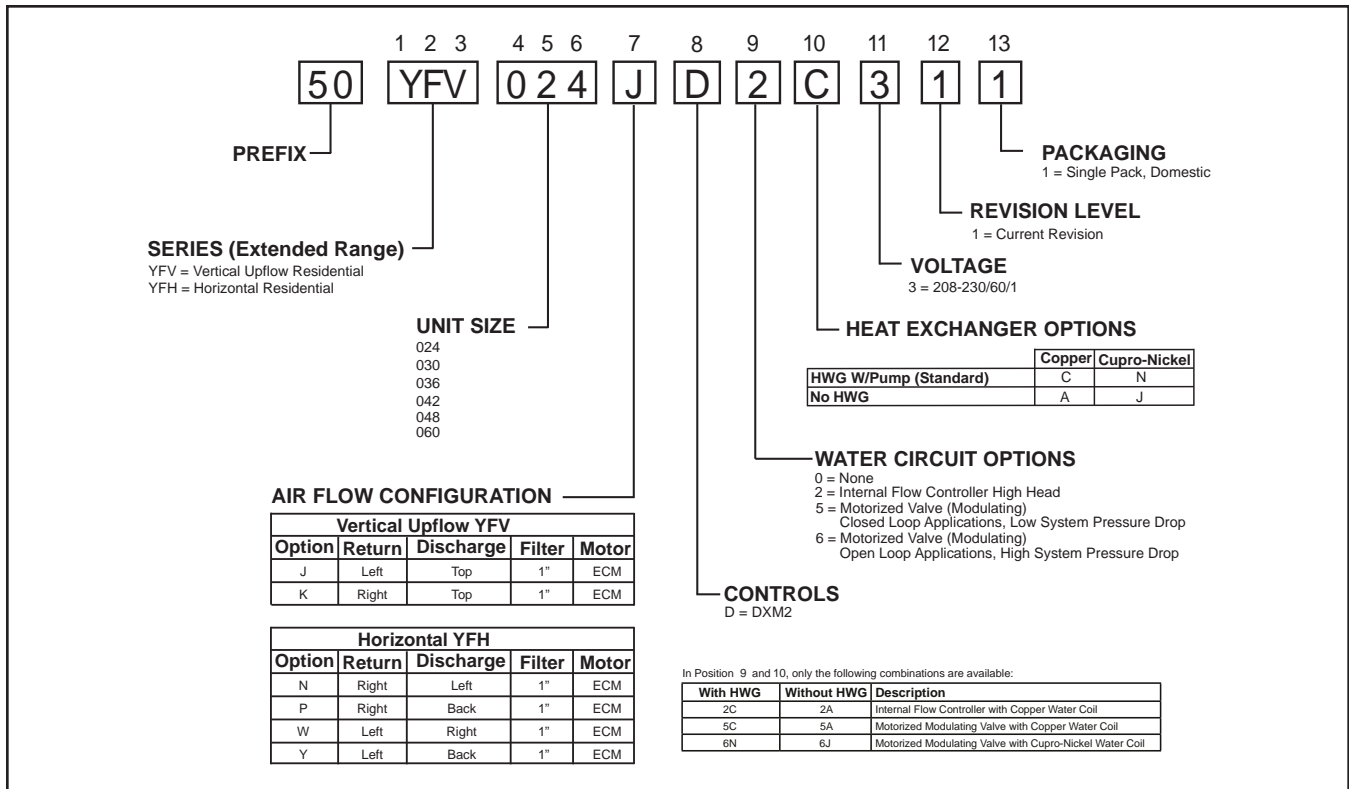

NOTE: Above model nomenclature is a general reference. Consult individual specification sections for detailed information.

Safety

Warnings, cautions and notices appear throughout this manual. Read these items carefully before attempting any installation, service, or troubleshooting of the equipment.

DANGER: Indicates an immediate hazardous situation, which if not avoided will result in death or serious injury. DANGER labels on unit access panels must be observed.

WARNING: Indicates a potentially hazardous situation, which if not avoided could result in death or serious injury.

⚠ WARNING! ⚠

WARNING! The Puron® Application and Service Manual should be read and understood before attempting to service refrigerant circuits with HFC-410A.

⚠ WARNING! ⚠

WARNING! To avoid the release of refrigerant into the atmosphere, the refrigerant circuit of this unit must be serviced only by technicians who meet local, state, and federal proficiency requirements.

CAUTION: Indicates a potentially hazardous situation or an unsafe practice, which if not avoided could result in minor or moderate injury or product or property damage.

NOTICE: Notification of installation, operation or maintenance information, which is important, but which is not hazard-related.

⚠ WARNING! ⚠

WARNING! All refrigerant discharged from this unit must be recovered WITHOUT EXCEPTION. Technicians must follow industry accepted guidelines and all local, state, and federal statutes for the recovery and disposal of refrigerants. If a compressor is removed from this unit, refrigerant circuit oil will remain in the compressor. To avoid leakage of compressor oil, refrigerant lines of the compressor must be sealed after it is removed.

⚠ CAUTION! ⚠

CAUTION! To avoid equipment damage, DO NOT use these units as a source of heating or cooling during the construction process. The mechanical components and filters will quickly become clogged with construction dirt and debris, which may cause system damage.

General Information

Inspection

Upon receipt of the equipment, carefully check the shipment against the bill of lading. Make sure all units and accessories have been received. Inspect the packaging of each unit, and inspect each unit for damage. Insure that the carrier makes proper notation of any shortages or damage on all copies of the freight bill and completes a common carrier inspection report. Concealed damage not discovered during unloading must be reported to the carrier within 15 days of receipt of shipment. If not filed within 15 days, the freight company can deny the claim without recourse. Note: It is the responsibility of the purchaser to file all necessary claims with the carrier. Notify your equipment supplier of all damage within fifteen (15) days of shipment.

Storage

Equipment should be stored in its original packaging in a clean, dry area. Store units in an upright position at all times. Stack units a maximum of 3 units high.

Unit Protection

Cover units on the job site with either the original packaging or an equivalent protective covering. Cap the open ends of pipes stored on the job site. In areas where painting, plastering, and/or spraying has not been completed, all due precautions must be taken to avoid physical damage to the units and contamination by foreign material. Physical damage and contamination may prevent proper start-up and may result in costly equipment clean-up.

Examine all pipes, fittings, and valves before installing any of the system components. Remove any dirt or debris found in or on these components.

Pre-Installation

Installation, Operation, and Maintenance instructions are provided with each unit. Horizontal equipment is designed for installation above false ceiling or in a ceiling plenum. Other unit configurations are typically installed in a mechanical room. The installation site chosen should include adequate service clearance around the unit. Before unit start-up, read all manuals and become familiar with the unit and its operation. Thoroughly check the system before operation.

Prepare units for installation as follows:

1. Compare the electrical data on the unit nameplate with ordering and shipping information to verify that the correct unit has been shipped.
2. Keep the cabinet covered with the original packaging until installation is complete and all plastering, painting, etc. is finished.
3. Verify refrigerant tubing is free of kinks or dents and that it does not touch other unit components.
4. Inspect all electrical connections. Connections must be clean and tight at the terminals.
5. Remove any blower support packaging (water-to-air units only).
6. Locate and verify any hot water generator (HWG), hanger, or other accessory kit located in the compressor section or blower section.

⚠ CAUTION! ⚠

CAUTION! DO NOT store or install units in corrosive environments or in locations subject to temperature or humidity extremes (e.g., rooftops, etc. See Tables 9a and 9b for acceptable temperature ranges). Corrosive conditions and high temperature or humidity can significantly reduce performance, reliability, and service life. Always move and store units in an upright position. Tilting units on their sides may cause equipment damage.

⚠ CAUTION! ⚠

CAUTION! CUT HAZARD - Failure to follow this caution may result in personal injury. Sheet metal parts may have sharp edges or burrs. Use care and wear appropriate protective clothing, safety glasses and gloves when handling parts and servicing heat pumps.

Duct System Installation

The duct system should be sized to handle the design airflow quietly. Refer to Figure 6a and 6b for horizontal duct system details or Figure 2 for vertical duct system details. A flexible connector is recommended for both discharge and return air duct connections on metal duct systems to eliminate the transfer of vibration to the duct system. To maximize sound attenuation of the unit blower, the supply and return plenums should include internal fiberglass duct liner or be constructed from ductboard for the first few feet. Application of the unit to uninsulated ductwork in an unconditioned space is not recommended, as the unit's performance will be adversely affected.

At least one 90° elbow should be included in the supply duct to reduce air noise. If air noise or excessive air flow is a problem, the blower speed can be changed. For airflow charts, consult catalog specifications for the series and model of the specific unit.

If the unit is connected to existing ductwork, a previous check should have been made to insure that the ductwork has the capacity to handle the airflow required for the unit. If ducting is too small, as in the replacement of a heating only system, larger ductwork should be installed. All existing ductwork should be checked for leaks and repaired as necessary.

The installation of geothermal heat pump units and all associated components, parts and accessories which make up the GHP system shall be in accordance with the regulations of ALL authorities having jurisdiction and MUST conform to all applicable codes. It is the responsibility of the installing contractor to determine and comply with ALL applicable codes and regulations.

Vertical Installation

Vertical Unit Location

Packaged units are not designed for outdoor installation. Locate the unit in an INDOOR area that allows enough space for service personnel to perform typical maintenance or repairs without removing the unit from the installed location. Vertical units are typically installed in a mechanical closet or basement. Never install units in areas subject to freezing or where humidity levels could cause cabinet condensation (such as unconditioned spaces subject to 100% outside air). Also, provide sufficient room to make water, electrical, and duct connection(s).

If the unit is located in a confined space, such as a closet, provisions must be made for return air to freely enter the space by means of a louvered door or other method. Any access panel screws that would be difficult to remove after the unit is installed should be removed prior to setting the unit. Refer to Figures 1 and 2 for typical installation illustrations. Refer to unit catalog specifications for dimensional data.

1. Install the unit on a piece of rubber, neoprene or other mounting pad material for sound isolation. The pad should be at least 3/8" [10mm] to 1/2" [13mm] in thickness. Extend the pad beyond all four edges of the unit.
2. Do not block filter access with piping, conduit or other materials. Refer to unit catalog specifications for dimensional data.
3. Provide access to water valves and fittings and screwdriver access to the unit side panels, discharge collar and all electrical connections.

Figure 1: Vertical Unit Mounting

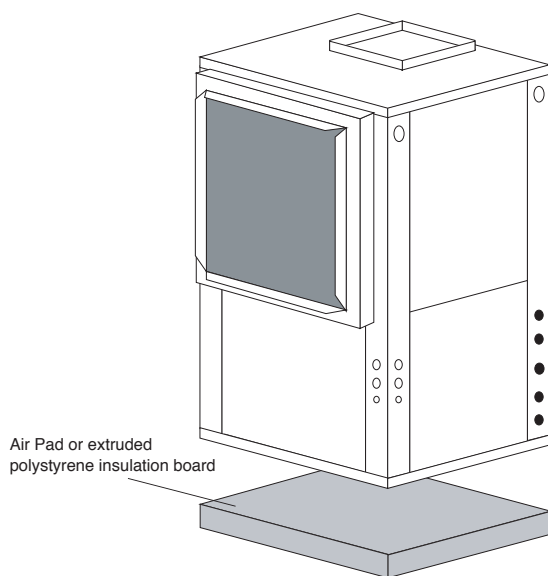
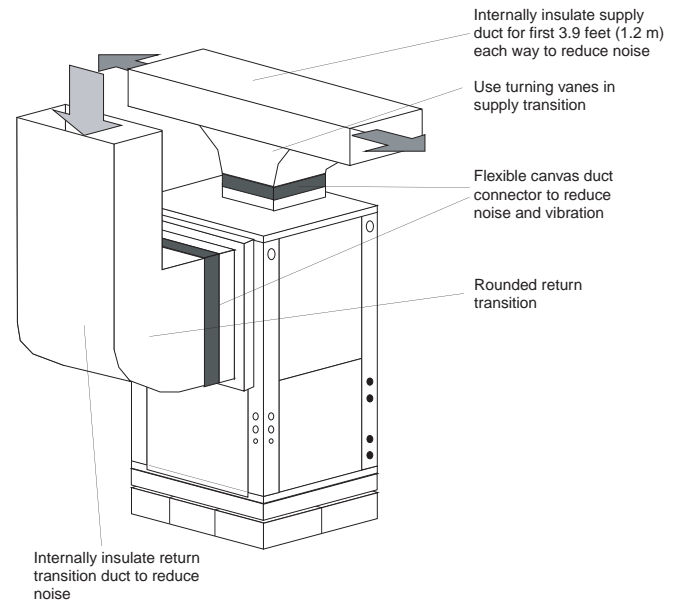

Figure 2: Typical Vertical Unit Installation Using Ducted Return Air



Sound Attenuation for Vertical Units

Sound attenuation is achieved by enclosing the unit within a small mechanical room or a closet. Additional measures for sound control include the following:

1. Mount the unit so that the return air inlet is 90° to the return air grille (refer to Figure 3). Install a sound baffle as illustrated to reduce line-of sight sound transmitted through return air grilles.
2. Mount the unit on a unit isolation pad to minimize vibration transmission to the building structure. For more information on unit isolation pads, contact your distributor.

Figure 3: Vertical Sound Attenuation

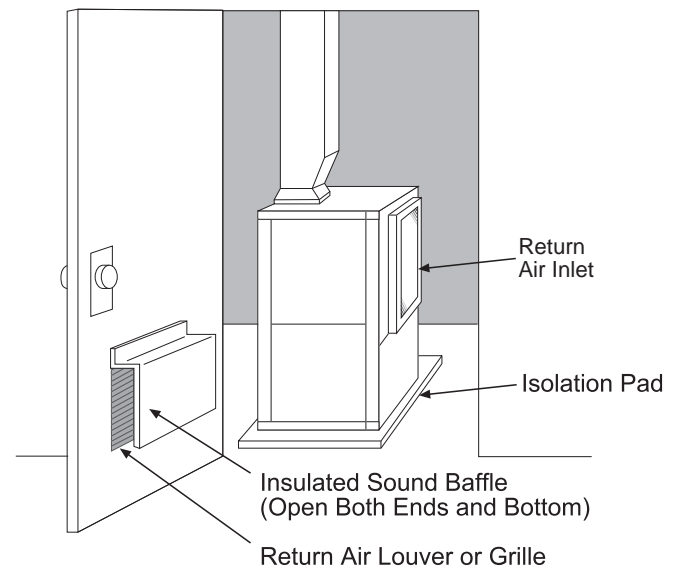

Horizontal Installation

Horizontal Unit Location

Packaged units are not designed for outdoor installation. Locate the unit in an INDOOR area that allows enough space for service personnel to perform typical maintenance or repairs without removing unit from the ceiling. Horizontal units are typically installed above a false ceiling or in a ceiling plenum. Never install units in areas subject to freezing or where humidity levels could cause cabinet condensation (such as unconditioned spaces subject to 100% outside air). Consideration should be given to access for easy removal of the filter and access panels. Provide sufficient room to make water, electrical, and duct connection(s).

If the unit is located in a confined space, such as a closet, provisions must be made for return air to freely enter the space by means of a louvered door or any other method. Any access panel screws that would be difficult to remove after the unit is installed should be removed prior to setting the unit. Refer to Figures 7a and 7b for an illustration of a typical installation. Refer to unit catalog specifications for dimensional data.

Conform to the following guidelines when selecting a unit location:

1. Provide a hinged access door in concealed-spline or plaster ceilings. Provide removable ceiling tiles in T-bar or lay-in ceilings. Refer to horizontal unit dimensions for specific series and model in unit catalog specifications. Size the access opening to accommodate the service technician during the removal or replacement of the compressor and the removal or installation of the unit itself.
2. Provide access to hanger brackets, water valves and fittings. Provide screwdriver clearance to access panels, discharge collars and all electrical connections.
3. DO NOT obstruct the space beneath the unit with piping, electrical cables and other items that prohibit future removal of components or the unit itself.
4. Use a manual portable jack/lift to lift and support the weight of the unit during installation and servicing.

The installation of geothermal heat pump units and all associated components, parts and accessories which make up the GHP system shall be in accordance with the regulations of ALL authorities having jurisdiction and MUST conform to all applicable codes. It is the responsibility of the installing contractor to determine and comply with ALL applicable codes and regulations.

Mounting Horizontal Units

Horizontal units have hanger kits pre-installed from the factory as shown in Figure 5. Figures 7a and 7b shows a typical horizontal unit installation.

Horizontal heat pumps are typically suspended above a ceiling or within a soffit using field supplied, threaded rods sized to support the weight of the unit.

Use four (4) field supplied threaded rods and factory provided vibration isolators to suspend the unit. Hang the unit clear of the floor slab above and support the unit by the mounting bracket assemblies only. DO NOT attach the unit flush with the floor slab above.

Pitch the unit toward the drain as shown in Figure 6 to improve the condensate drainage. On small units (less than 2.5 Tons/8.8 kW) ensure that unit pitch does not cause condensate leaks inside the cabinet.

NOTE: The top panel of a horizontal unit is a structural component. The top panel of a horizontal unit must never be removed from an installed unit unless the unit is properly supported from the bottom. Otherwise, damage to the unit cabinet may occur.

Figure 4: Hanger Bracket

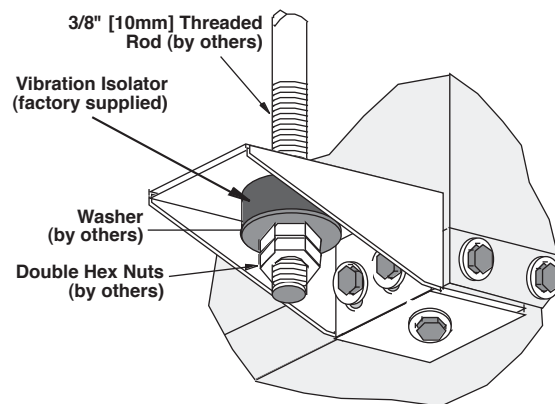
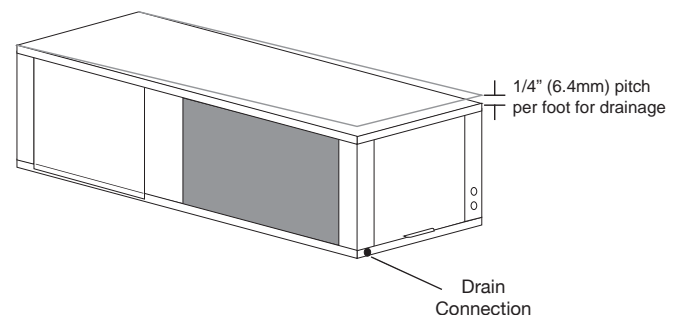
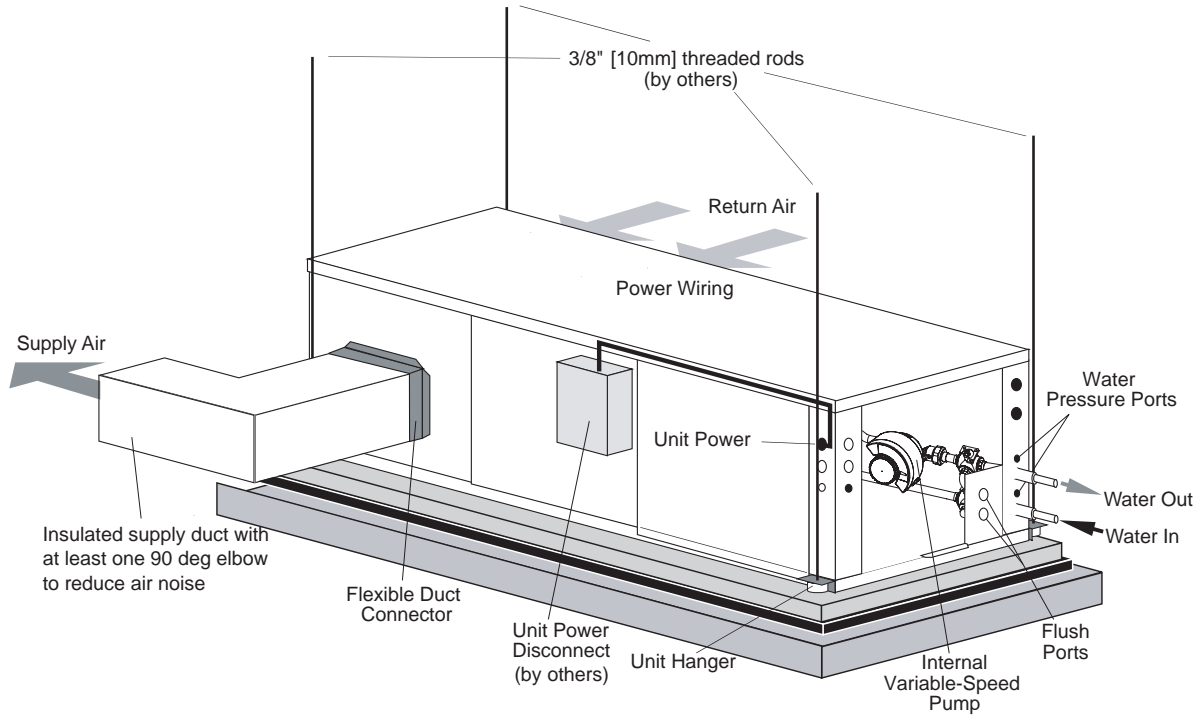

Figure 5: Horizontal Unit Pitch



Horizontal Installation

Figure 6a: Typical Closed Loop Horizontal Unit Installation (with Internal Flow Controller)



Air Coil - To obtain maximum performance, the air coil should be cleaned before start-up. A 10% solution of dishwasher detergent and water is recommended for both sides of the coil. A thorough water rinse should follow.

Figure 6b: Typical Ground Water Horizontal Unit Installation (with Internal Motorized Modulating Valve)

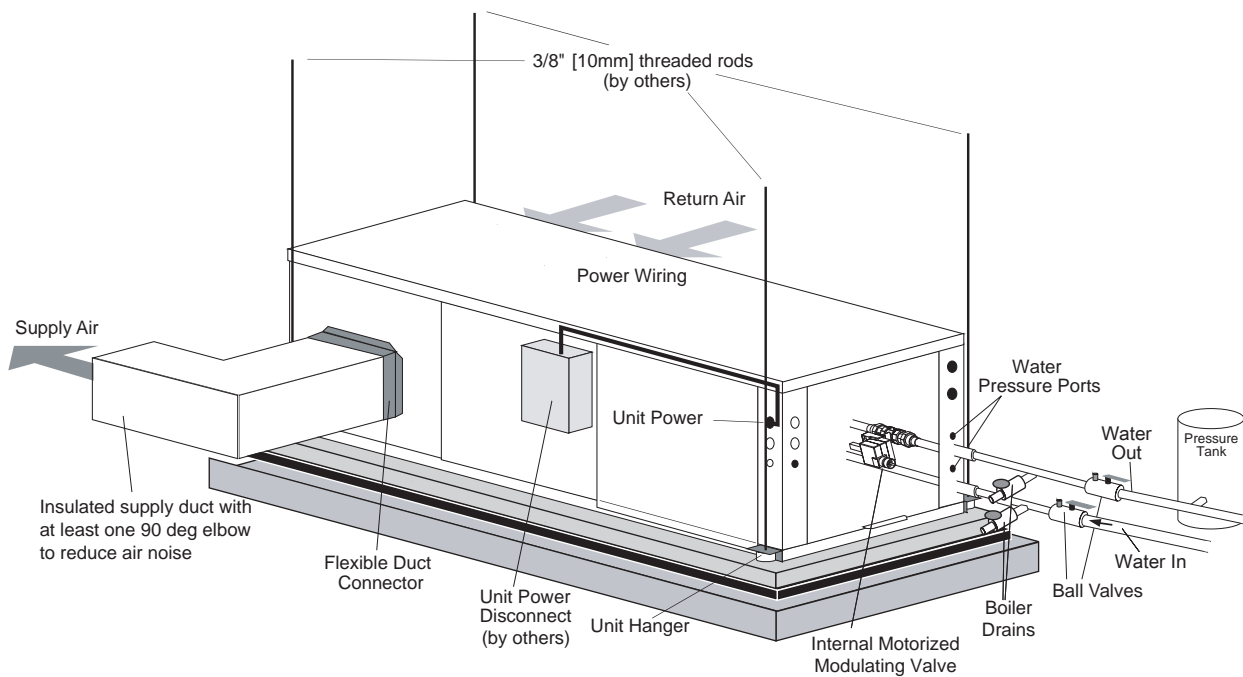

Horizontal Installation

Field Conversion of Air Discharge

Overview - Horizontal units can be field converted between side (straight) and back (end) discharge using the instructions below.

Note: It is not possible to field convert return air between left or right return models due to the necessity of refrigeration copper piping changes.

Preparation - It is best to field convert the unit on the ground before hanging. If the unit is already hung it should be taken down for the field conversion.

Side to Back Discharge Conversion

1. Place unit in well lit area. Remove the screws as shown in Figure 8 to free top panel and discharge panel.
2. Lift out the access panel and set aside. Lift and rotate the discharge panel to the other position as shown, being careful with the blower wiring.
3. Check blower wire routing and connections for tension or contact with sheet metal edges. Reroute if necessary.
4. Check refrigerant tubing for contact with other components.
5. Reinstall top panel and screws noting that the location for some screws will have changed.
6. Manually spin the fan wheel to ensure that the wheel is not rubbing or obstructed.
7. Replace access panels.

Back to Side Discharge Conversion - If the discharge is changed from back to side, use above instruction noting that illustrations will be reversed.

Left vs. Right Return - It is not possible to field convert return air between left or right return models due to the necessity of refrigeration copper piping changes. However, the conversion process of side to back or back to side discharge for either right or left return configuration is the same. In some cases, it may be possible to rotate the entire unit 180 degrees if the return air connection needs to be on the opposite side. Note that rotating the unit will move the piping to the other end of the unit.

Figure 7: Left Return Side to Back

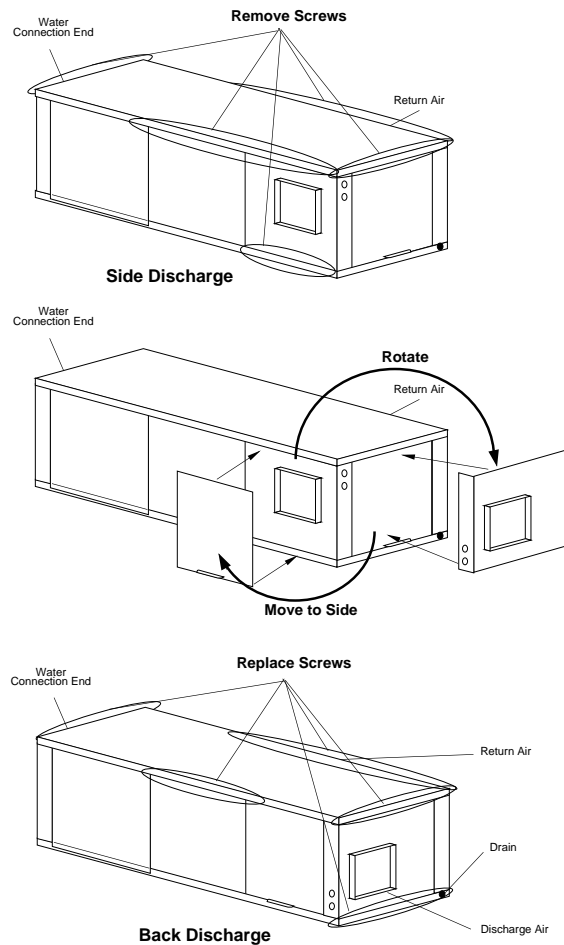
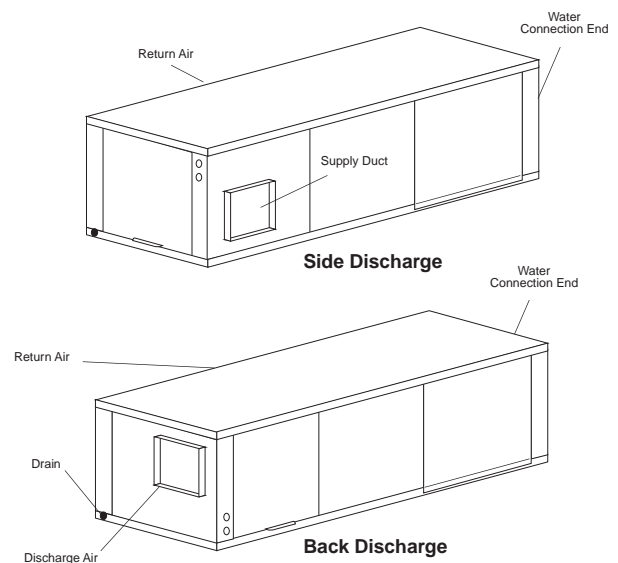

Figure 8: Right Return Side to Back



Condensate and Water Connection

Condensate Piping

Pitch the unit toward the drain as shown in Figure 6 to improve the condensate drainage. On small units (less than 2.5 tons/8.8 kW), insure that unit pitch does not cause condensate leaks inside the cabinet.

Install condensate trap at each unit with the top of the trap positioned below the unit condensate drain connection as shown in Figure 9. Design the depth of the trap (water-seal) based upon the amount of External Static Pressure (ESP) capability of the blower (where 2 inches [51mm] of ESP capability requires 2 inches [51mm] of trap depth). As a general rule, 1-1/2 inch [38mm] trap depth is the minimum.

Each unit must be installed with its own individual trap and connection to the condensate line (main) or riser. Provide a means to flush or blow out the condensate line. **DO NOT** install units with a common trap and/or vent.

Always vent the condensate line when dirt or air can collect in the line or a long horizontal drain line is required. Also vent when large units are working against higher external static pressure than other units connected to the same condensate main since this may cause poor drainage for all units on the line. **WHEN A VENT IS INSTALLED IN THE DRAIN LINE, IT MUST BE LOCATED AFTER THE TRAP IN THE DIRECTION OF THE CONDENSATE FLOW.**

Figure 9: Condensate Connection

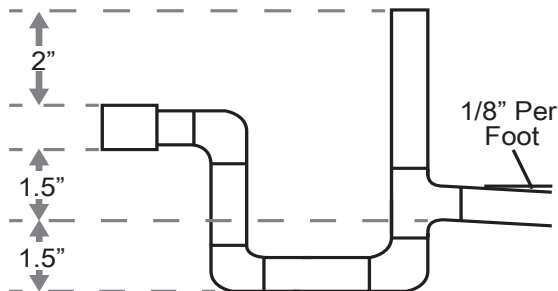

* Some units include a painted drain connection. Using a threaded pipe or similar device to clear any excess paint accumulated inside this fitting may ease final drain line installation.

⚠ CAUTION! ⚠

CAUTION! Ensure condensate line is pitched toward drain 1/8 inch per ft [11mm per m] of run.

Water Connections-Residential (Distributor) Models

Residential models utilize swivel piping fittings for water connections that are rated for 450 psi (3101 kPa) operating pressure. The connections have a rubber gasket seal similar to a garden hose gasket, which when mated to the flush end of most 1" threaded male pipe fittings provides a leak-free seal without the need for thread sealing tape or joint compound. Check for burrs and ensure that the rubber seal is in the swivel connector prior to attempting any connection (rubber seals are shipped attached to the swivel connector). **DO NOT OVER TIGHTEN** or leaks may occur.

The female locking ring is threaded onto the pipe threads which holds the male pipe end against the rubber gasket, and seals the joint. **HAND TIGHTEN ONLY! DO NOT OVERTIGHTEN!**

Figure 11: Water Connections

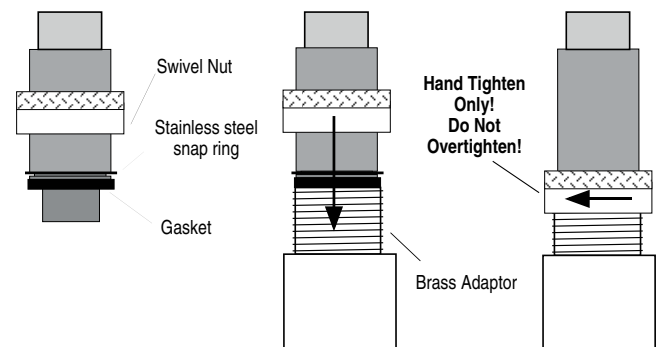

⚠ CAUTION! ⚠

CAUTION! The following instructions represent industry accepted installation practices for closed loop earth coupled heat pump systems. Instructions are provided to assist the contractor in installing trouble free ground loops. These instructions are recommendations only. State/provincial and local codes **MUST** be followed and installation **MUST** conform to **ALL** applicable codes. It is the responsibility of the installing contractor to determine and comply with **ALL** applicable codes and regulations.

Integrated Variable Speed Water Flow Control Heat Pump Applications Overview

Integrated Variable Speed Water Flow Control is a revolutionary new, intelligent, and efficient way to circulate water (or water plus antifreeze) using INTERNAL, variable water flow control. The factory-installed high-efficiency variable-speed pump uses 60%-80% less wattage than a traditional fixed speed pump. Integrated Variable Speed Water Flow Control technology improves performance of the unit by reducing the amount of energy required to optimize the flow of water throughout a GHP System and also reduces the space, cost, and labor required to install external water flow control mechanisms (flow controllers, solenoid and flow control valves).

Integrated Variable Speed Water Flow Control Configurations:

1) Internal Flow Controller - For Closed Loop Applications

This is the most common configuration for closed loops. With this factory-installed standard option, the unit is built with an Internal Variable Speed Pump and other components to flush and operate the unit correctly (including an expansion tank, flush ports and flushing valves). The pump speed is controlled by the DXM2 control based on the difference in entering and leaving water temperatures (ΔT). The Internal Flow Controller pump includes an internal check valve for multiple unit installations. A copper water coil is standard with this option.

Note: Internal Flow Controllers are also very suitable for multiple unit installations depending on pump performance requirements.

2) Internal Modulating Motorized Valve – For Large Closed Loop Applications (external central pumping)

Primarily for use on multi-unit closed loop applications with central pumping. With this factory-installed option, the unit includes a low pressure drop modulating motorized valve that is controlled by the DXM2 microprocessor control based on the difference in the entering and leaving water temperatures (ΔT). A Copper Water Coil is standard with this option. The modulating valve in this option has a higher Cv than the open loop option.

3) Internal Modulating Motorized Valve - For Open Loop Applications

For use on open loop applications. With this factory-installed, standard option, the unit is built with an internal modulating motorized valve controlled by the Communicating DXM2 control board based on entering and leaving water temperatures (ΔT). A low Cv modulating motorized valve is used for this application to provide more precise control against the higher system pressure differential of open loop applications. A Cupro-Nickel water coil comes standard with this option.

Details on these options are included in the following sections on ground loop and ground water applications.

Figure 12a: Typical Closed-Loop Application (with Internal Flow Controller Shown)

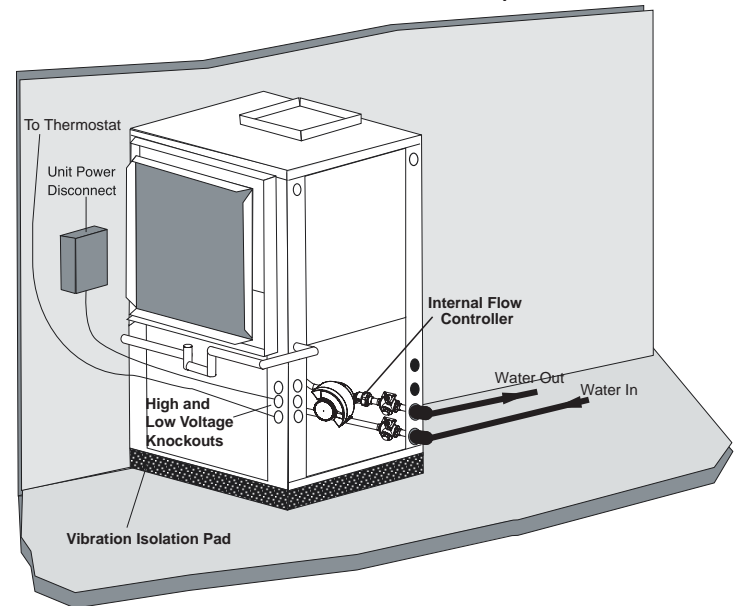
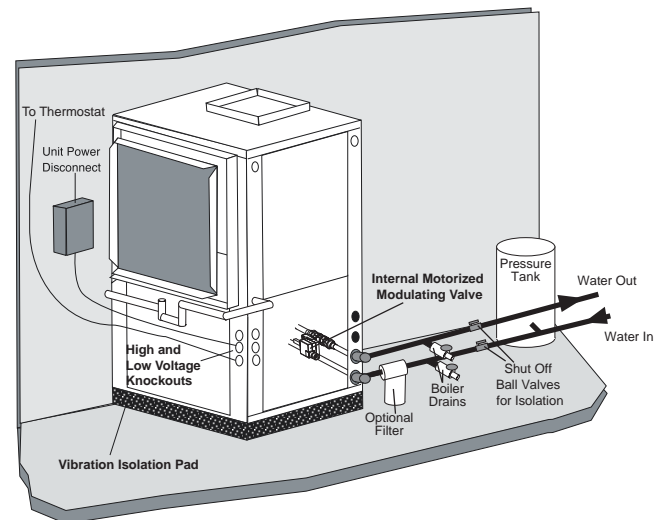

Figure 12b: Typical Open Loop Application (with Internal Modulating Motorized Valve Shown)

For use on applications using external source for flow



Closed Loop Heat Pump Applications with Internal Flow Control

Units with internal flow control come with built-in variable speed pumps, an expansion tank, flushing ports and a three way valve (used to flush the unit). The variable speed pump is controlled by the Communicating DXM2 board based on the difference between the entering and leaving water temperature (ΔT). For operation outside of the normal entering water temperature range (50° or 60°F - 110°F for cooling, 30°F-70°F for heating) the DXM2 controller may automatically adjust the control ΔT to account for the abnormal entering water temperatures, maintaining an appropriate flow rate for proper unit operation. The expansion tank helps to maintain constant loop pressure despite the natural expansion and contraction of the loop as the seasons and loop temperatures vary.

GT-PB Packaged Digital units with Internal Flow Controller option are also provided with an expansion tank to help maintain positive pressure on the complete system through all seasons.

Pre-Installation

Prior to installation, locate and mark all existing underground utilities, piping, etc. Install loops for new construction before sidewalks, patios, driveways, and other construction has begun. During construction, accurately mark all ground loop piping on the plot plan as an aid in avoiding potential future damage to the installation.

Piping Installation

The typical closed loop ground source system is shown in Figure 12a. All earth loop piping materials should be limited to polyethylene fusion only for in-ground sections of the loop. Galvanized or steel fittings should not be used at any time due to their tendency to corrode. All plastic to metal threaded fittings should be avoided due to their potential to leak in earth coupled applications. A flanged fitting should be substituted. Earth loop temperatures can range between 25 and 110°F [-4 to 43°C]. Flow rates between 2.25 and 3

Internal Flow Controller

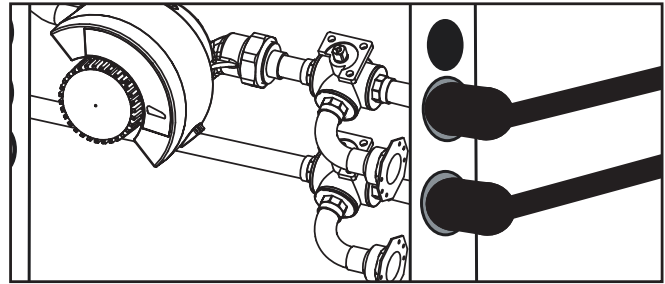

gpm per ton [2.41 to 3.23 l/m per kW] of cooling capacity is recommended in these applications.

Test individual horizontal loop circuits before backfilling. Test vertical U-bends and pond loop assemblies prior to installation. Pressures of at least 100 psi [689 kPa] should be used when testing. Do not exceed the pipe pressure rating. Test entire system when all loops are assembled.

▲ NOTICE! ▲

NOTICE! If installing MULTIPLE Internal Variable Speed Flow Controller units (in parallel) on one loop, please refer to section 'Multiple Unit Piping and Flushing' (later in this document).

The following section will help to guide you through flushing a unit with internal flow control.

Pressure/Water Ports

The pressure ports built in to the unit are provided as a means of measuring drop through the unit. The water flow through the unit can be checked by measuring the incoming water pressure at the supply water pressure port and subtracting the leaving water pressure at the return water pressure port. Comparing the pressure differential to the pressure drop table/flow rate in Tables 14a through 14k in this manual will determine the flow rate through the unit.

Chart 2: Internal Variable Speed Flow Controller Maximum Performance

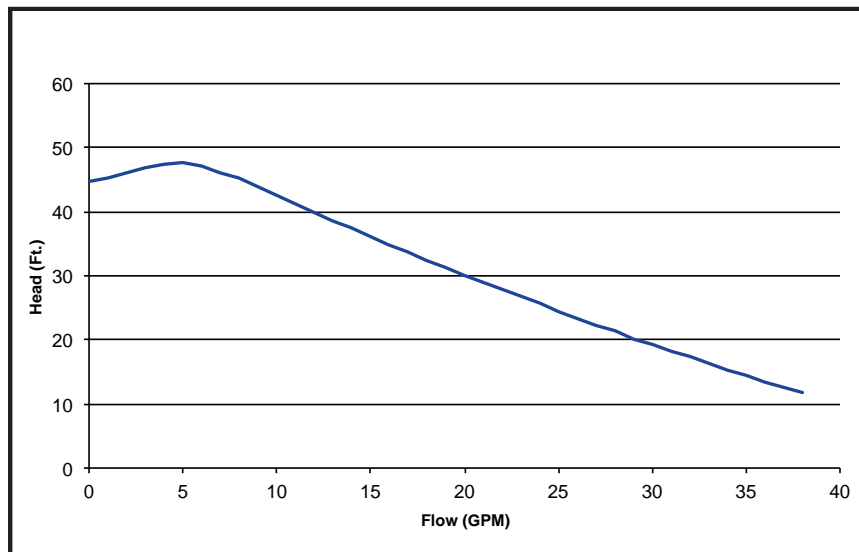

GPM	Head (ft)	GPM	Head (ft)
0.0	44.7	21.0	28.9
1.0	45.4	22.0	27.8
2.0	46.1	23.0	26.7
3.0	46.8	24.0	25.6
4.0	47.5	25.0	24.5
5.0	47.7	26	23.4
6.0	47.1	27	22.3
7.0	46.1	28	21.3
8.0	45.3	29	20.2
9.0	43.9	30	19.2
10.0	42.6	31	18.2
11.0	41.2	32	17.3
12.0	39.9	33	16.3
13.0	38.7	34	15.4
14.0	37.4	35	14.4
15.0	36.1	36	13.5
16.0	34.9	37	12.6
17.0	33.7	38	11.7
18.0	32.5		
19.0	31.3		
20.0	30.1		

Flushing the Earth Loop

Once piping is completed between the unit and the ground loop, final purging and charging of the loop is needed.

A flush cart (at least a 1.5 hp [1.1kW] pump) is needed to achieve adequate flow velocity in the loop to purge air and dirt particles from the loop itself. Antifreeze solution is used in most areas to prevent freezing. All air and debris must be removed from the earth loop piping system before operation, Flush the loop with a high volume of water at a high velocity (2 fps [0.6 m/s] in all piping), using a filter in the loop return line, of the flush cart to eliminate debris from the loop system. See Table 17 for flow rate required to attain 2fps [0.6 m/s]. The steps below must be followed for proper flushing.

Table 1: Minimum Flow Required to Achieve 2 ft/sec variety

PE Pipe Size	Flow (GPM)
3/4"	4
1"	6
1 1/4"	10
1 1/2"	13
2"	21

Units with internal variable speed pumps also include a check valve internal to the pump. It is not possible to flush backwards through this pump. Care must be taken to connect the flush cart hoses so that the flush cart discharge is connected to the "water in" flushing valve of the heat pump.

Loop Fill

Fill loop (valve position A, see Figure 15a) with water from a garden hose through flush cart before using flush cart pump to ensure an even fill and increase flushing speed. When water consistently returns back to the flush reservoir, switch to valve position B (figure 15b).

Isolate expansion tank for flushing procedure using the ball valve. During dead heading of flush cart pump, isolation will prevent compression of bladder in the expansion tank and flush cart fluid level dropping below available capacity.

Figure 14a: Typical Cleanable Flush Cart Strainer (100 mesh [0.149mm])



⚠ WARNING! ⚠

WARNING! Disconnect electrical power source to prevent injury or death from electrical shock.

Figure 14b: Cam Fittings for Flush Cart Hoses

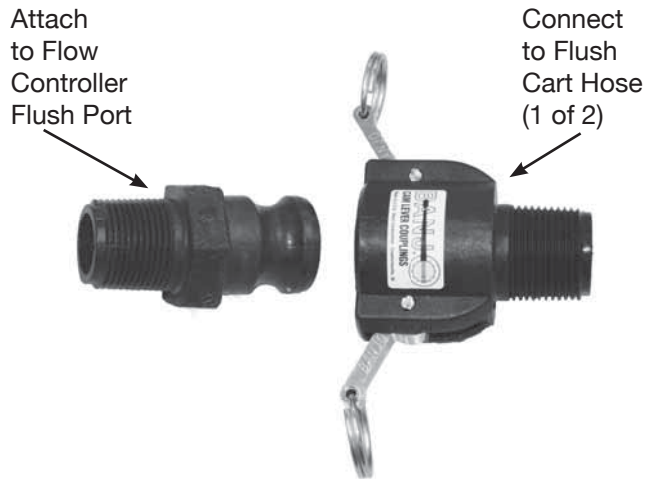

NOTICE: A hydrostatic pressure test is required on ALL piping, especially underground piping before final backfill per IGSHPA and the pipe manufacturers recommendations.

Figure 15a: Valve Position A - Loop Fill/Flush

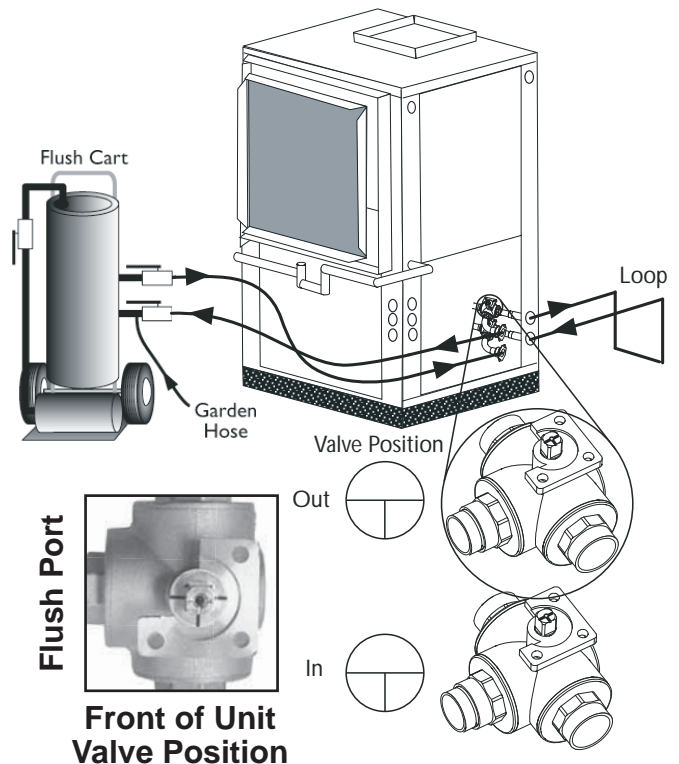

Flushing the Earth Loop

Figure 15b: Valve Position B - Unit Fill / Flush

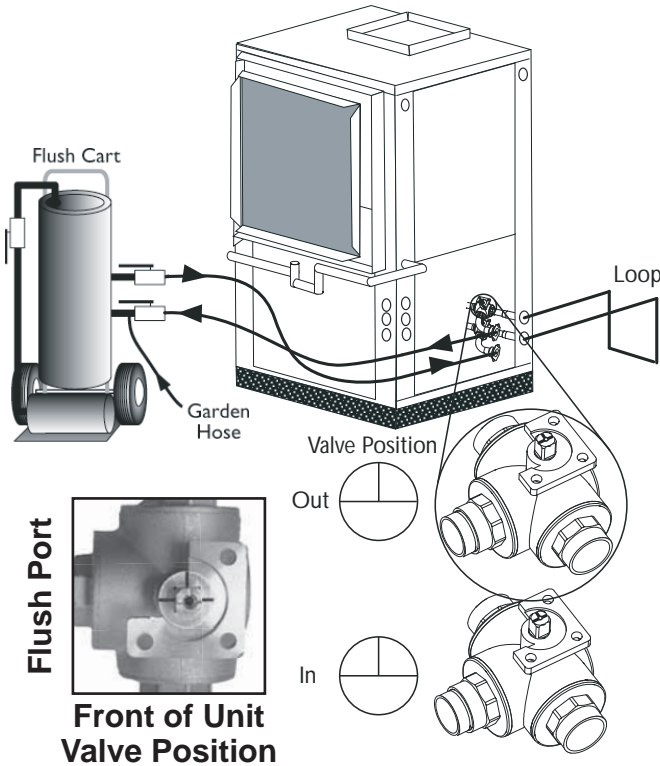

Unit Fill

Unit fill valves should be switched to Position B while flush cart is pumping to fill the unit heat exchanger (see Figure 15b). The valves position should be maintained until water is consistently returned into the flush reservoir.

Loop Flush

Switch to valve Position A. The supply water may be shut off and the flush cart turned on to begin flushing. Once the flush reservoir is full, do not allow the water level in the flush cart tank to drop below the pump inlet line or air can be pumped back out to the earth loop. Try to maintain a fluid level in the tank above the return tee so that air can not be continuously mixed back into the fluid. Surges of 50 psi [345 kPa] can be used to help purge air pockets by simply shutting off the flush cart return valve going into the flush cart reservoir. This process 'dead heads' the pump to 50 psi [345 kPa]. To dead head the pump until maximum pumping pressure is reached, open the valve back up and a pressure surge will be sent through the loop to help purge air pockets from the piping system. Notice the drop in fluid level in the flush cart tank. If all air is purged from the system, the level will drop only 3/8" in a 10" [25.4 cm] diameter PVC flush tank (about a half gallon [1.9 liters]) since liquids are incompressible. If the level drops more than this level, flushing should continue since air is still being compressed in the loop fluid. Do this a number of times.

NOTICE: Actual flushing time require will vary for each installation due to piping length, configuration, and flush cart pump capacity. 3/8" or less fluid level drop is the ONLY indication that flushing is complete.

Switch valves to Position B to flush the unit. Flush through the unit until all air pockets have been removed.

Move valves to position C. By switching both valves to this position, water will flow through the loop and the unit heat exchanger. Finally, the dead head test should be checked again for an indication of air in the loop. Fluid level drop is your only indication of air in the loop.

Figure 15d: Valve Position C - Full Flush

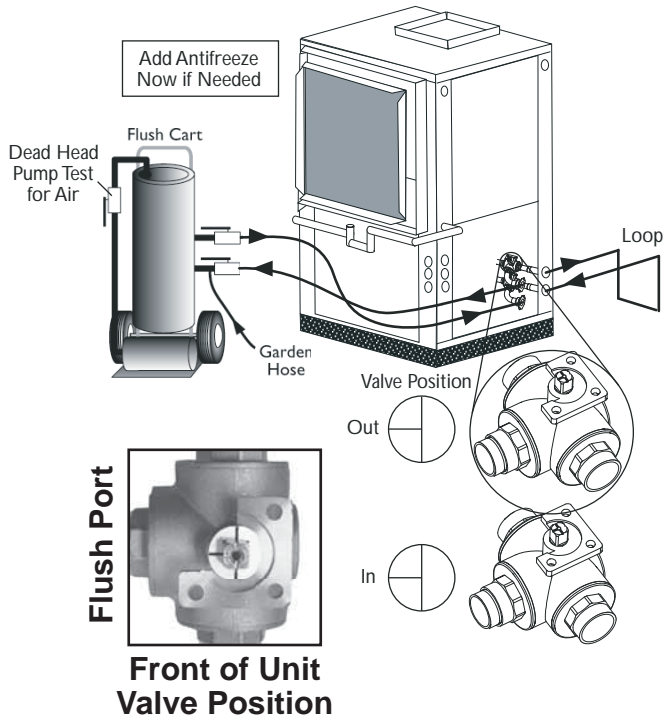

Pressurize and Operate

As shown in Figure 15e, close the flush cart return valve to pressurize the loop to at least 50 psi [345 kPa], not to exceed 75 psi [517 kPa]. Open the isolation valve to the expansion tank and bleed air from the expansion tank piping using the schraeder valve located in front of the expansion tank. This will allow loop pressure to compress the expansion tank bladder, thus charging the expansion tank with liquid. After pressurizing, close the flush cart supply valve to isolate the flush cart. Move the Flow Controller valves to Position D.

Loop static pressure will fluctuate with the seasons and pressures will be higher in the winter months than during the cooling season. This fluctuation is normal and should be considered when charging the system initially. Unhook

Flushing the Earth Loop

the flush cart from the Internal Flow Controller. Install Flow Controller caps to ensure that any condensation/leakage remains contained within the Flow Controller package.

If the loop pressure is between 50 and 75 psi [345 to 517 kPa] upon completion of flushing, pressures should be sufficient for all seasons.

NOTICE: It is recommended to run the unit in the cooling, then heating mode for 15-20 minutes each to 'temper' the fluid temperature and prepare it for pressurization. This procedure helps prevent the periodic "flat" loop condition of no pressure.

Figure 15e: Valve Position D - Pressurize and Operation

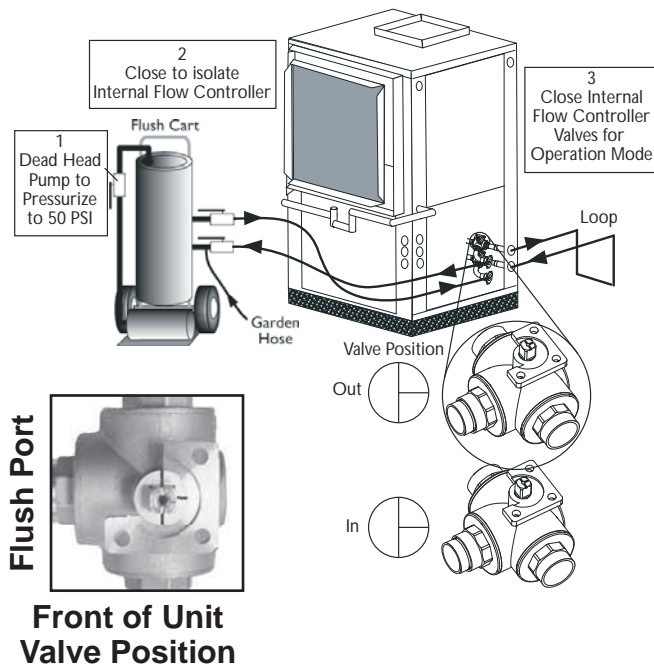

Multiple Unit Piping and Flushing

Often projects require more than one heat pump. Where possible, it makes sense for multiple units to share a common ground loop. Common ground loops for multiple units bring new challenges including the need to avoid backward flow through inactive units, increased pumping requirements, and more complex flushing needs. Three types of multiple unit systems are described below along with guidelines for installation of each type.

Integrated Variable Speed Water Flow Control technology is a great assist for systems with multiple units. Integrated Variable Speed Water Flow Control is available in three different configurations:

1. Internal variable-speed pump
2. Internal modulating valve for closed loops
3. Internal modulating valve for open loops

The internal modulating valve for open loops version should never be used on closed loops.

The internal variable speed pump version of Integrated Variable Speed Water Flow Control includes an internal Magna variable speed circulator controlled by the DXM2 microprocessor, internal 3-way flushing valves, an internal bladder type expansion tank, and front-mounted pressure ports that allow access to the pressure drop across the coaxial heat exchanger only. The Magna pump includes an internal check valve. The pump curve for the Magna circulator is shown in Figure 13. The internal expansion tank will operate as a pressure battery for the geothermal system. It will absorb fluid from the loop when loop pressure rises and inject fluid into the loop when loop pressure falls. In this way the expansion tank will help to maintain a more constant loop pressure and avoid flat loops due to seasonal pressure changes in the loop.

When using the internal variable speed pump as the loop pump in multiple unit installations it is important to ensure that the variable speed pump can provide adequate flow through the heat pump against the loop head when all units are operating.

It may be possible to flush a multiple unit system through the unit's flushing valves. Flushing pressure drop of the valve may be calculated to determine if it is acceptable. Engineering data for the 3-way flushing valves can be found in Table 2.

Table 2: Internal 3-Way Flushing Valve Data

Model	Flushing Connection	Straight Flow Cv	90° Flow Cv
YF024 - 42	3/4" FPT	25	10.3
YF048 - 60	1" FPT	58	14.5

For example, if a system includes two 2-ton units and four ¾ loop circuits we can calculate the flushing pressure drop as

follows. From Table 1 we know that it will take 4 gpm to flush each ¾ circuit. If there is no provision to isolate the circuits for flushing, we will have to flush with a minimum of 4 circuits x 4 gpm/circuit = 16 gpm total. A check of other piping sizes used must be done to ensure that 16 gpm total flow will flush all piping.

Pressure drop through the flushing valve can be calculated using the following formula.

$$\Delta P = (GPM/Cv)^2 \text{ where,}$$

ΔP = pressure drop in psi through the valve while flushing
 GPM = flushing flow in gallons per minute
 Cv = valve Cv in flushing mode

We know from Table 2 that the Cv for the flushing valve in a YG026 is 10.3 in the flushing mode (90° flow). Therefore, $\Delta P = (GPM/Cv)^2 = (16/10.3)^2 = 2.4$ psi per valve (there are two flushing valves). So long as the flushing pump is able to provide 16 gpm at the flushing pressure drop of the loop plus the 2.4 x 2 valves = 4.8 psi of the flushing valves, the internal flushing valves may be used. If the flushing pump is not able to overcome the pressure drop of the internal flushing valves, then larger external flushing valves must be used.

Unit Configuration

Multiple units with internal variable-speed flow controller and check valve, piped in parallel sharing a common loop **MUST** be configured for 'VS PUMP PARALLEL' in Installer Settings Menu.

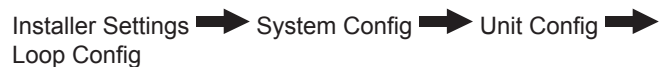
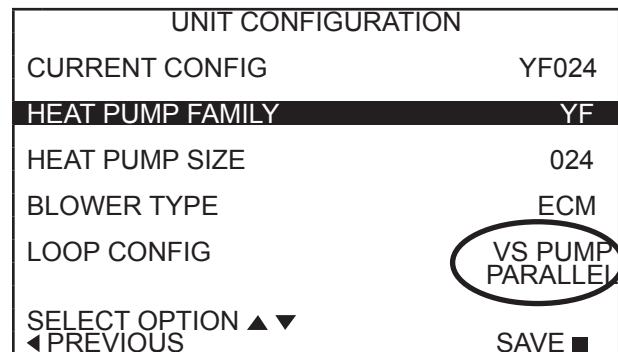

Multiple Units with Internal Flow Controllers

The simplest multiple unit system is one with two (or more) units utilizing internal Flow Controllers with no external pumps or flushing valves. In this case the units are piped in parallel and use the internal flushing valves to flush the system. The variable speed pump includes an internal check valve to prevent back (short circuiting) flow through the units.

In this case, flush the loop through the internal flushing valves in the unit farthest from the loop first. Once the loop is flushed, then change the internal flushing valves to flush the heat pump. Next, move the flushing cart to the next closest unit to the loop.

Multiple Unit Piping and Flushing

Again, flush the loop through the internal flushing valves. This is important as there may be air/debris in the lines from this unit to the common piping. Once flushing begins the air will be moved into the loop and will need to be flushed out. After the loop is flushed through the second unit, change the flushing valves to flush the second unit. This process should be repeated for additional units working from the farthest from the loop to the closest to the loop.

This type of application can generally be employed for systems to 12 tons depending on loop design. However, it is important to perform appropriate calculations to confirm that the variable speed pump can provide adequate flow through all heat pumps against the loop head when all units are operating.

Figure 16a: Multiple Units with Internal Flow Controllers

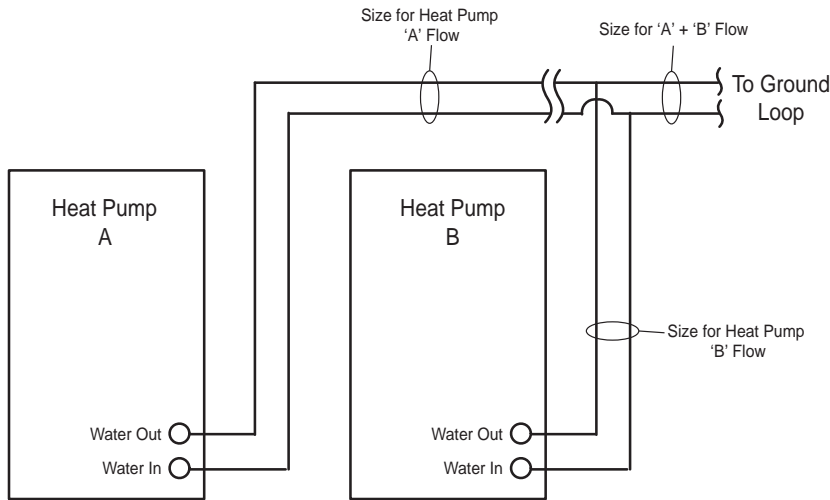

Multiple Units with Internal Flow Controllers and External Flushing Valves

When the number of units or flushing requirements reaches a point where it is no longer feasible to flush through the internal valves (generally systems of more than 12 tons depending on loop design), external flushing valves should be installed. In this case, three-way flushing valves should be used or additional isolation valves must be installed to be able to isolate the loop during flushing.

Figure 16b: Multiple Units with Internal Flow Controllers and External Flushing Valves

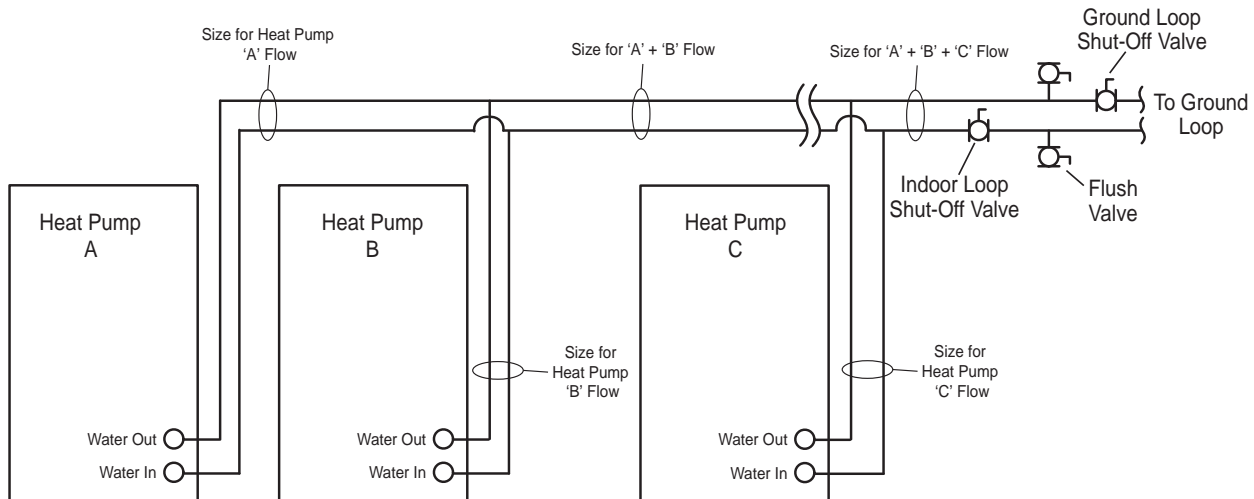

First, flush the ground loop. The installer should close the indoor loop shut-off valve (or the internal flushing valves in all units) and open the ground loop shut-off valve to prevent flow through the indoor loop while flushing the ground loop.

Once the ground loop is flushed, close the ground loop shut-off valve and open the indoor loop valve(s) to flush the units and indoor piping. Remember that there is an internal check valve in the variable speed pump and that backward flow the unit is not possible.

Multiple Unit Piping and Flushing

Multiple Units with Internal Modulating Valves and Central Pump

This is an application where multiple units are used in conjunction with a central, variable speed pump. In this case, units with closed loop modulating valves are used (do not use open loop modulating valves on a closed loop system). External flushing valves are required. This application is for larger systems, including commercial.

Figure 16c: Multiple Units with Internal Modulating Valves and Central Pump

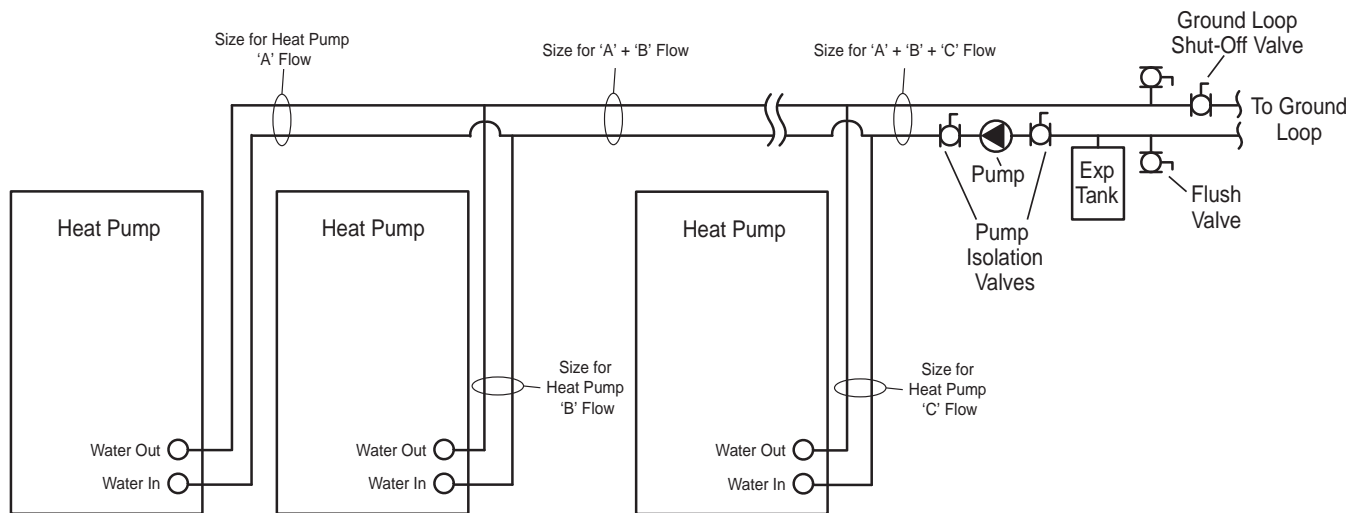

Before flushing, the installer should manually open all modulating valves as detailed in Closed Loop – External Central Pumping section of this manual. Next, flush the ground loop. The installer should close a pump isolation valve and open the ground loop shut-off valve to prevent flow through the indoor loop while flushing the ground loop.

Once the ground loop is flushed, close the ground loop shut-off valve and open the pump isolation valve to flush the units and indoor piping. Once the system is flushed remember to return the modulating valves to their normal operating position.

Ground Loop Applications

Antifreeze Selection - General

In areas where minimum entering loop temperatures drop below 40°F [4.4°C] or where piping will be routed through areas subject to freezing, antifreeze is needed. Alcohols and glycols are commonly used as antifreeze solutions. Your local representative should be consulted for the antifreeze best suited to your area. Freeze protection should be maintained to 15°F [8.5°C] below the lowest expected entering loop temperature.

Initially calculate the total volume of fluid in the piping system using Table 3. Then use the percentage by volume shown in Table 4 for the amount of antifreeze. Antifreeze concentration should be checked from a well mixed sample using a hydrometer to measure specific gravity.

Table 3: Fluid Volume

Fluid Volume (gal [liters] per 100' [30 meters] Pipe)		
Pipe	Size	Volume (gal) [liters]
Copper	1"	4.1 [15.3]
	1.25"	6.4 [23.8]
	2.5"	9.2 [34.3]
Polyethylene	3/4" IPS SDR11	2.8 [10.4]
	1" iPS SDR11	4.5 [16.7]
	1.25" IPS SDR11	8.0 [29.8]
	1.5" IPS SDR11	10.9 [40.7]
	2" IPS SDR11	18.0 [67.0]
Unit Heat Exchanger	Typical	1.0 [3.8]
Flush Cart Tank	10" Dia x 3ft tall [254mm x 91.4cm tall]	10 [37.9]

⚠ WARNING! ⚠

WARNING! Always dilute alcohols with water (at least 50% solution) before using. Alcohol fumes are flammable and can cause serious injury or death if not handled properly.

When handling methanol (or any alcohol), always wear eye protection and rubber gloves as alcohols are easily absorbed through the skin.

Table 4: Antifreeze Percentages by Volume

Type	Minimum Temperature for Low Temperature Protection			
	10°F [-12.2°C]	15°F [-9.4°C]	20°F [-6.7°C]	25°F [-3.9°C]
Methanol	21%	17%	13%	8%
Propylene Glycol	29%	24%	18%	12%
Ethanol*	23%	20%	16%	11%

* Must not be denatured with any petroleum based product

Contact your distributor if you have any questions as to antifreeze selection.

⚠ WARNING! ⚠

WARNING! Always use properly marked vehicles (D.O.T. placards), and clean/suitable/properly identified containers for handling flammable antifreeze mixtures. Post and advise those on the jobsite of chemical use and potential dangers of handling and storage.

NOTICE: DO NOT use automotive windshield washer fluid as antifreeze. Washer fluid contains chemicals that will cause foaming.

⚠ CAUTION! ⚠

CAUTION! Always obtain MSDS safety sheets for all chemicals used in ground loop applications including chemicals used as antifreeze.

Antifreeze Charging

It is highly recommended to utilize premixed antifreeze fluid where possible to alleviate many installation problems and extra labor.

The following procedure is based upon pure antifreeze and can be implemented during the Full Flush procedure with three way valves in the Figure 15d - Valve Position C. If a premixed mixture of 15°F [-9.4°C] freeze protection is used, the system can be filled and flushed with the premix directly to prevent handling pure antifreeze during the installation.

- 1) Flush loop until all air has been purged from system and pressurize to check for leaks before adding any antifreeze.
- 2) Run discharge line to a drain and hook up antifreeze drum to suction side of pump (if not adding below water level through approved container). Drain flush cart reservoir down to pump suction inlet so reservoir can accept the volume of antifreeze to be added.
- 3) Calculate the amount of antifreeze required by first calculating the total fluid volume of the loop from Table 3. Then calculate the amount of antifreeze needed using Table 2 for the appropriate freeze protection level. Many southern applications require freeze protection because of exposed piping to ambient conditions.
- 4) Isolate unit and prepare to flush only through loop (see Figure 15a). Start flush cart, and gradually introduce the required amount of liquid to the flush cart tank (always introduce alcohols under water or use suction of pump to draw in directly to prevent fuming) until attaining the proper antifreeze protection. The rise in flush reservoir level indicates amount of antifreeze added (some carts are marked with measurements in gallons or liters). A ten inch [25.4 cm] diameter cylinder, 3 foot [91.4 cm] tall holds approximately 8 gallons [30.3 liters] of fluid plus the hoses (approx. 2 gallons, [7.6 liters]), which equals about

Ground Loop Applications

10 gallons [37.9 liters] total. If more than one tankful is required, the tank should be drained immediately by opening the waste valve of the flush cart noting the color of the discharge fluid. Adding food coloring to the antifreeze can help indicate where the antifreeze is in the circuit and prevents the dumping of antifreeze out the waste port. Repeat if necessary.

- 5) Be careful when handling methanol (or any alcohol). Always wear eye protection and rubber gloves. The fumes are flammable, and care should be taken with all flammable liquids. Open flush valves to flush through both the unit and the loop and flush until fluid is homogenous and mixed. It is recommended to run the unit in the heating and cooling mode for 15-20 minutes each to 'temper' the fluid temperature and prepare it for pressurization. Devoting this time to clean up can be useful. This procedure helps prevent the periodic "flat" loop condition.
- 6) Close the flush cart return valve; and immediately thereafter, close the flush cart supply valve, leaving a positive pressure in the loop of approximately 50 psi [345 kPa]. This is a good time to pressure check the system as well. Check the freeze protection of the fluid with the proper hydrometer to ensure that the correct amount of antifreeze has been added to the system. The hydrometer can be dropped into the flush reservoir and the reading compared to Chart 1a for Methanol, 1b for Propylene Glycol, and 1c for Ethanol to indicate the level of freeze protection. Do not antifreeze more than a +10°F [-12.2°C] freeze point. Specific gravity hydrometers are available in the residential price list. Repeat after reopening and flushing for a minute to ensure good second sample of fluid. Inadequate antifreeze protection can cause nuisance low temperature lockouts during cold weather.

⚠ WARNING! ⚠

WARNING! Always dilute alcohols with water (at least 50% solution) before using. Alcohol fumes are flammable and can cause serious injury or death if not handled properly.

When handling methanol (or any alcohol), always wear eye protection and rubber gloves as alcohols are easily absorbed through the skin.

- 7) Close the flush cart return valve; immediately thereafter, close the flush cart supply valve, shut off the flush cart leaving a positive pressure in the loop of approximately 50-75 psi [345-517 kPa]. Refer to Figure 15e for more details.

Low Water Temperature Cutout Setting - DXM2 Control
When antifreeze is selected, the LT1 jumper (JW3) should be clipped to select the low temperature (antifreeze 10°F [-12.2°C]) set point and avoid nuisance faults (see "Low Water Temperature Cutout Selection" in this manual).

Chart 1a: Methanol Specific Gravity

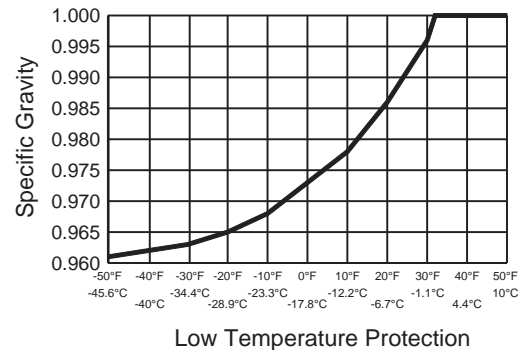

Chart 1b: Propylene Glycol Specific Gravity

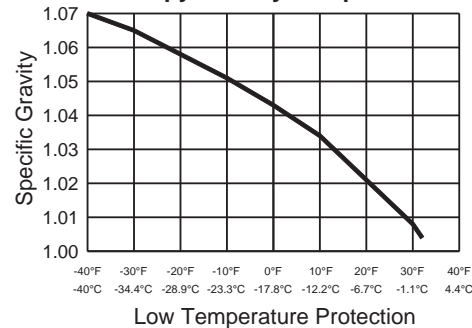

Chart 1c: Ethanol Specific Gravity

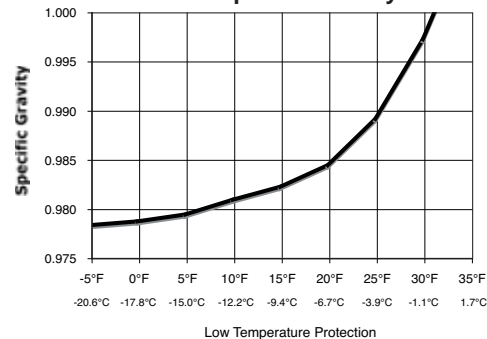
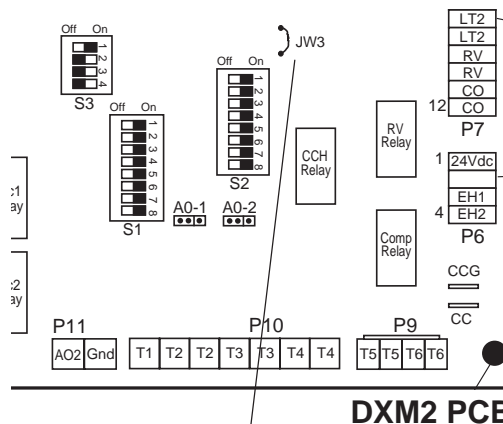

Figure 17: Low Temperature Cutout Selection



JW3-LT1 jumper should be clipped for low temperature operation

Closed Loop - External Central Pumping Applications

Figure 18: Typical Closed Loop with Central Pumping Application (with Internal Modulating Motorized Valve Shown)

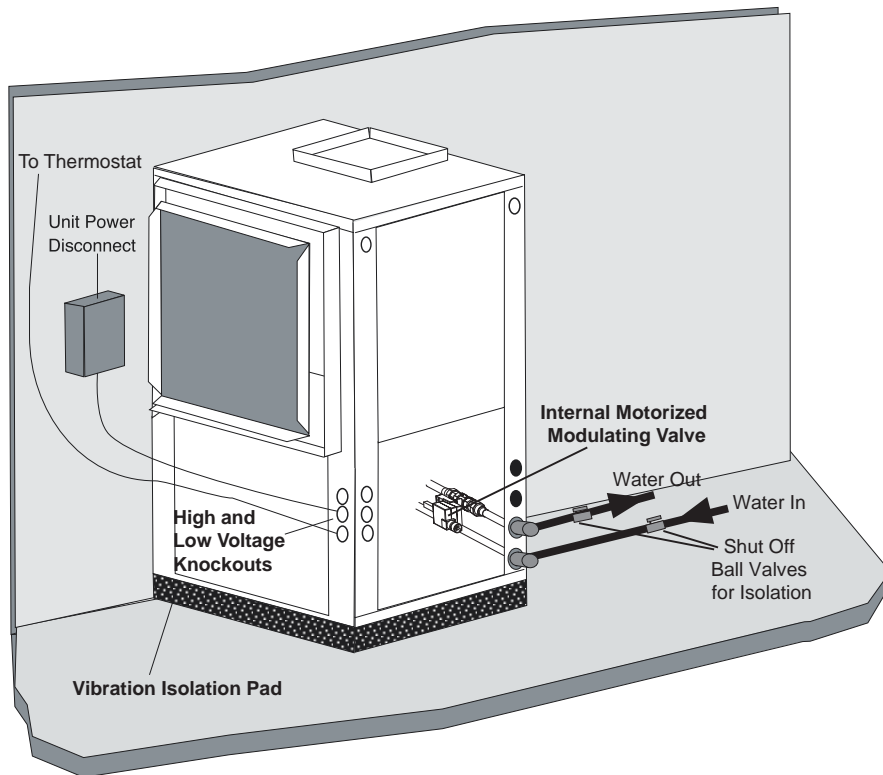

GT-PB packaged units are available with a modulating water valve option for closed-loop applications with external central pumping (designated by a 5 in the 11th position of the unit model number). With this option, the Modulating Valve is regulated by the Communicating DXM2 board based on entering and leaving water temperature (ΔT). The DXM2 board outputs a 0-10v signal to determine valve position (flow rate). The modulating valve defaults to closed position if it loses signal but still has 24V power running to it. If the motorized modulating valve loses both signal from the DXM2 board AND 24V power, it will remain in the same position it was in when it lost 24V power.

Note: The Cv (flow coefficient) of the valve used in these units is DIFFERENT that the Cv of the valve used in the open loop unit. It is not advisable for use in open loop applications as sound/noise issues may result. Units with the water circuit for closed loop, central pumping option are only available with a copper water coil.

To manually open the internal modulating motorized water valve in YF024 – 036 push down on the handle to unlock it. Then rotate the handle to the open position as shown in Figure 18. This fully opens the valve for flushing. Once flushing is complete, return the valve handle to its normally closed position.

To manually open the internal modulating motorized water valve in YF048 – 060, push down on the lock release button while turning the handle to the open position as shown in Figure 19. This fully opens the valve for flushing. Once flushing is complete, press the lock release again and return the valve handle to its normally closed position.

Figure 19: Internal Modulating Motorized Valve Positions

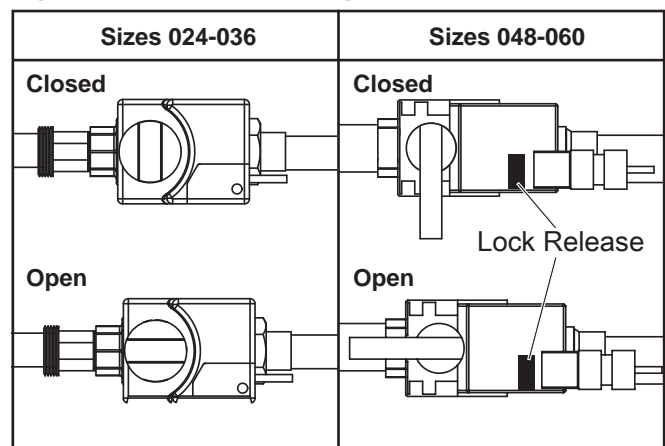

Open Loop or Ground-Water Applications

Figure 20: Typical Open Loop/Well Application

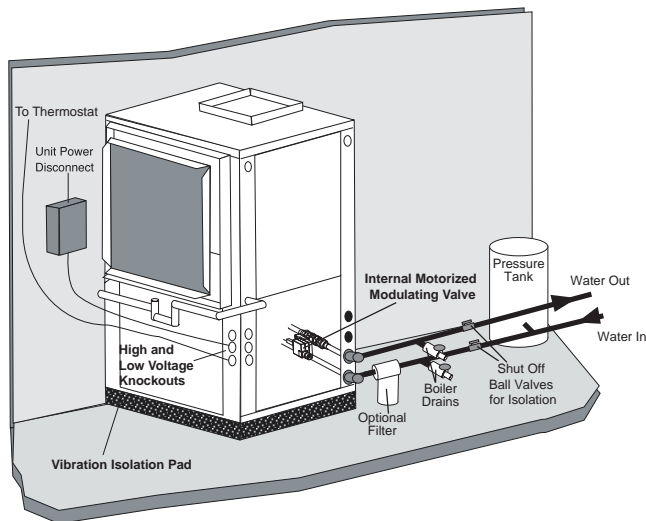

⚠ CAUTION! ⚠

CAUTION! Refrigerant pressure activated water regulating valves should never be used with this equipment.

GT-PB packaged units are available with a water circuit option for open loop applications (designated by a 6 in the 11th position of the unit model number).

The Motorized Modulating Valve is regulated by the Communicating DXM2 board based on entering and leaving water temperature (ΔT). The DXM2 board gives a 0-10v signal to determine flow rate. The motorized modulating valve defaults to closed position if it loses signal but still has 24V power running to it. If the motorized modulating valve loses both signal from the DXM2 board AND 24V power, it will remain in the same position it was in when it lost 24V power. **DO NOT USE** open loop units in closed loop applications due to significant pressure drop through the open loop motorized modulating valve. This option is only available with Cupro-Nickel Water Coil.

To manually open the internal modulating motorized water valve in YF024 – 036 push down on the handle to unlock it. Then rotate the handle to the open position as shown in Figure 19. This fully opens the valve for flushing. Once flushing is complete, return the valve handle to its normally closed position.

To manually open the internal modulating motorized water valve in YF048 – 060, push down on the lock release button while turning the handle to the open position as shown in Figure 19. This fully opens the valve for flushing. Once

flushing is complete, press the lock release again and return the valve handle to its normally closed position.

Open Loop - Ground Water Systems

Typical open loop piping is shown in Figure 20. Shut off valves should be included for ease of servicing. Boiler drains or other valves should be “tee’d” into the lines to allow acid flushing of the heat exchanger. Shut off valves should be positioned to allow flow through the coax via the boiler drains without allowing flow into the piping system. Schrader ports built into unit may be used to measure heat exchanger pressure drop. Water temperature can be viewed on the communicating thermostat. Piping materials should be limited to copper, PE, or PVC SCH80. Note: Due to the pressure and temperature extremes, PVC SCH40 is not recommended.

Water quantity should be plentiful and of good quality. Consult Table 5 for water quality requirements. Integrated Variable Speed Water Flow Control units for open loop applications always come with Cupro-Nickel coils. In ground water situations where scaling could be heavy or where biological growth such as iron bacteria will be present, an open loop system is not recommended. Heat exchanger coils may over time lose heat exchange capabilities due to build up of mineral deposits. Heat exchangers must only be serviced by a qualified technician, as acid and special pumping equipment is required. Desuperheater coils can likewise become scaled and possibly plugged. In areas with extremely hard water, the owner should be informed that the heat exchanger may require occasional acid flushing. In some cases, the desuperheater option should not be recommended due to hard water conditions and additional maintenance required.

Water Quality Standards

Table 5 must be consulted for water quality requirements. Scaling potential should be assessed using the pH/Calcium hardness method. If the pH < 7.5 and the Calcium hardness is less than 100 ppm, scaling potential is low. If this method yields numbers out of range of those listed, a monitoring plan should be implemented in these probable scaling situations. Other water quality issues such as iron fouling, corrosion prevention and erosion and clogging should be referenced in Table 5.

Pressure Tank and Pump

Use a closed, bladder-type pressure tank to minimize mineral formation due to air exposure. The pressure tank should be sized to provide at least one minute continuous run time of the pump using its drawdown capacity rating to prevent pump short cycling. Discharge water from the unit is not contaminated in any manner and can be disposed of in various ways, depending on local building codes (e.g. recharge well, storm sewer, drain field, adjacent stream or pond, etc.). Most local codes forbid the use of sanitary sewer for disposal. Consult your local building and zoning department to assure compliance in your area.

Open Loop or Ground-Water Applications

The pump should be sized to handle the home's domestic water load (typically 5-9 gpm [23-41 l/m]) plus the flow rate required for the heat pump. Pump sizing and expansion tank must be chosen as complimentary items. For example, an expansion tank that is too small can cause premature pump failure due to short cycling. Variable speed pumping applications should be considered for the inherent energy savings and smaller pressure tank requirements.

Water Coil Low Temperature Limit Setting

For all open loop systems the 30°F [-1.1°C] LT1 setting (factory setting-water) should be used to avoid freeze damage to the unit. See "Low Water Temperature Cutout Selection" (Figure 17) in this manual for details on the low limit setting.

Water Quality Requirements

Table 5: Water Quality Requirements

Water Quality Parameter	HX Material	Closed Recirculating	Open Loop and Recirculating Well		
Scaling Potential - Primary Measurement					
Above the given limits, scaling is likely to occur. Scaling indexes should be calculated using the limits below					
pH/Calcium Hardness Method	All	-	pH < 7.5 and Ca Hardness <100ppm		
Index Limits for Probable Scaling Situations - (Operation outside these limits is not recommended)					
Scaling indexes should be calculated at 66°C for direct use and HWG applications, and at 32°C for indirect HX use. A monitoring plan should be implemented.					
Ryznar Stability Index	All	-	6.0 - 7.5 If >7.5 minimize steel pipe use.		
Langelier Saturation Index	All	-	-0.5 to +0.5 If <-0.5 minimize steel pipe use. Based upon 66°C HWG and Direct well, 29°C Indirect Well HX		
Iron Fouling					
Iron Fe ²⁺ (Ferrous) (Bacterial Iron potential)	All	-	<0.2 ppm (Ferrous) If Fe ²⁺ (ferrous)>0.2 ppm with pH 6 - 8, O ₂ <5 ppm check for iron bacteria.		
Iron Fouling	All	-	<0.5 ppm of Oxygen Above this level deposition will occur.		
Corrosion Prevention					
pH	All	6 - 8.5 Monitor/treat as needed	6 - 8.5 Minimize steel pipe below 7 and no open tanks with pH <8		
Hydrogen Sulfide (H ₂ S)	All	-	<0.5 ppm At H ₂ S>0.2 ppm, avoid use of copper and copper nickel piping or HX's. Rotten egg smell appears at 0.5 ppm level. Copper alloy (bronze or brass) cast components are OK to <0.5 ppm.		
Ammonia ion as hydroxide, chloride, nitrate and sulfate compounds	All	-	<0.5 ppm		
Maximum Chloride Levels	Maximum Allowable at maximum water temperature.				
			10°C	24°C	38°C
	Copper	-	<20ppm	NR	NR
	Cupronickel	-	<150 ppm	NR	NR
	304 SS	-	<400 ppm	<250 ppm	<150 ppm
316 SS	-	<1000 ppm	<550 ppm	< 375 ppm	
Titanium	-	>1000 ppm	>550 ppm	>375 ppm	
Erosion and Clogging					
Particulate Size and Erosion	All	<10 ppm of particles and a maximum velocity of 1.8 m/s Filtered for maximum 841 micron [0.84 mm, 20 mesh] size.	<10 ppm (<1 ppm "sandfree" for reinjection) of particles and a maximum velocity of 1.8 m/s. Filtered for maximum 841 micron 0.84 mm, 20 mesh] size. Any particulate that is not removed can potentially clog components.		

The Water Quality Table provides water quality requirements for coaxial heat exchangers. When water properties are outside of those requirements, an external secondary Rev.: 3/22/2012 heat exchanger must be used to isolate the heat pump heat exchanger from the unsuitable water. Failure to do so will void the warranty for the coaxial heat exchanger.

Notes:

- Closed Recirculating system is identified by a closed pressurized piping system.
- Recirculating open wells should observe the open recirculating design considerations.
- NR - Application not recommended.
- "-" No design Maximum.

Hot Water Generator

The HWG (Hot Water Generator) or desuperheater option provides considerable operating cost savings by utilizing heat energy from the compressor discharge line to help satisfy domestic hot water requirements. The HWG is active throughout the year, providing virtually free hot water when the heat pump operates in the cooling mode or hot water at the COP of the heat pump during operation in the heating mode. Actual HWG water heating capacities are provided in the appropriate heat pump performance data.

Heat pumps equipped with the HWG option include a built-in water to refrigerant heat exchanger that eliminates the need to tie into the heat pump refrigerant circuit in the field. The control circuit and pump are also built in for residential equipment. Figure 21a shows a typical example of HWG water piping connections on a unit with built-in circulating pump. This piping layout prevents sludge/debris from the bottom of the tank being pulled into the HWG pump.

The temperature set point of the HWG is field selectable to 125°F or 150°F. The 150°F set point allows more heat storage from the HWG. For example, consider the amount of heat that can be stored by the HWG when using the 125°F set point, versus the amount of heat that can be generated by the HWG when using the 150°F set point.

In a typical 50 gallon two-element electric water heater the lower element should be turned down to 100°F, or the lowest setting, to get the most from the HWG. The tank will eventually stratify so that the lower 80% of the tank, or 40 gallons, becomes 100°F (controlled by the lower element). The upper 20% of the tank, or 10 gallons, will be maintained at 125°F (controlled by the upper element).

Using a 125°F set point, the HWG can heat the lower 40 gallons of water from 100°F to 125°F, providing up to 8,330 btu's of heat. Using the 150°F set point, the HWG can heat the same 40 gallons of water from 100°F to 150°F and the remaining 10 gallons of water from 125°F to 150°F, providing a total of up to 18,743 btu's of heat, or more than twice as much heat as when using the 125°F set point.

Electric water heaters are recommended. If a gas, propane, or oil water heater is used, a second preheat tank must be installed (Figure 21b). If the electric water heater has only a single center element, the dual tank system is recommended to insure a usable entering water temperature for the HWG.

Typically a single tank of at least 50 gallons (189 liters) is used to limit installation costs and space. However, a dual tank, as shown in Figure 21b, is the preferred system, as it provides the maximum storage and temperate source water to the HWG.

It is always advisable to use water softening equipment on domestic water systems to reduce the scaling potential and lengthen equipment life. In extreme water conditions, it may be necessary to avoid the use of the HWG option since the potential cost of frequent maintenance may offset or exceed any savings. Consult Table 5 for scaling potential tests.

Figure 21a: Typical HWG Installation

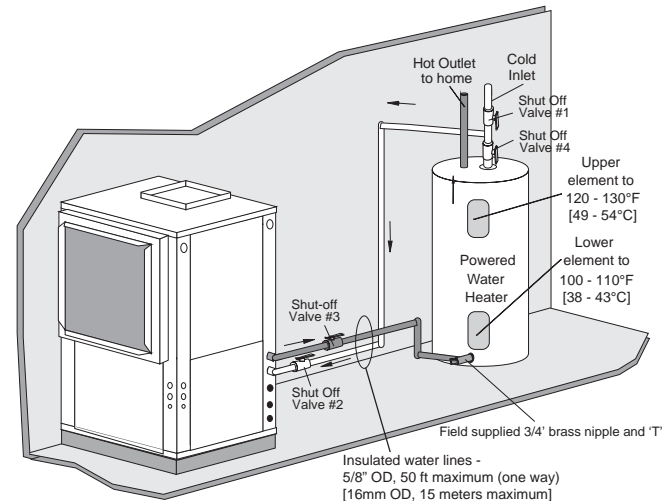
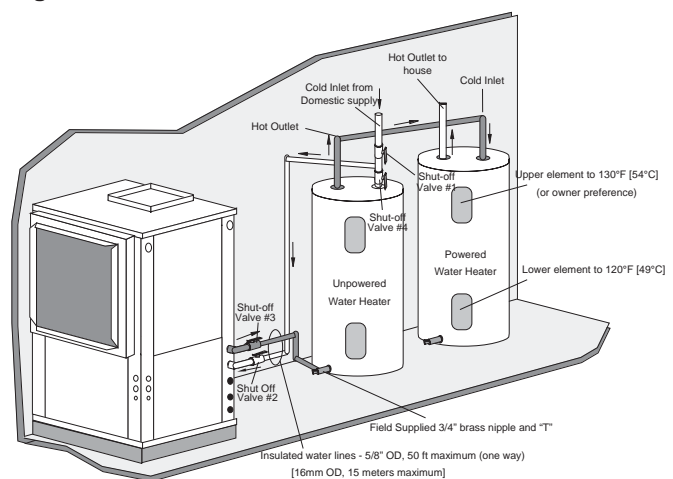

Figure 21b: HWG Double Tank Installation



⚠ WARNING! ⚠

WARNING! A 150°F SETPOINT MAY LEAD TO SCALDING OR BURNS. THE 150°F SET POINT MUST ONLY BE USED ON SYSTEMS THAT EMPLOY AN APPROVED ANTI-SCALD VALVE.

Hot Water Generator

Installation

The HWG is controlled by two sensors and the DXM2 microprocessor control. One sensor is located on the compressor discharge line to sense the discharge refrigerant temperature. The other sensor is located on the HWG heat exchanger's "Water In" line to sense the potable water temperature.

⚠ WARNING! ⚠

WARNING! UNDER NO CIRCUMSTANCES SHOULD THE SENSORS BE DISCONNECTED OR REMOVED. FULL LOAD CONDITIONS CAN DRIVE HOT WATER TANK TEMPERATURES FAR ABOVE SAFE TEMPERATURE LEVELS IF SENSORS DISCONNECTED OR REMOVED.

The DXM2 microprocessor control monitors the refrigerant and water temperatures to determine when to operate the HWG. The HWG will operate any time the refrigerant temperature is sufficiently above the water temperature. Once the HWG has satisfied the water heating demand during a heat pump run cycle, the controller will cycle the pump at regular Intervals to determine if an additional HWG cycle can be utilized.

When the control is powered and the HWG pump output is active for water temperature sampling or HWG operation, the DXM2 status LED will slowly flash (On 1 second, Off 1 second).

If the control has detected a HWG fault, the DXM2 status LED will flash a numeric fault code as follows:

High Water Temperature (>160°F)	5 flashes
Hot Water Sensor Fault	6 flashes
Compressor Discharge Sensor Fault	6 flashes

Fault code flashes have a duration of 0.3 seconds with a 10 second pause between fault codes. For example, a "Compressor Discharge sensor fault" will be six flashes 0.3 seconds long, then a 10 second pause, then six flashes again, etc.

⚠ WARNING! ⚠

WARNING! USING A 150°F SETPOINT ON THE HWG WILL RESULT IN WATER TEMPERATURES SUFFICIENT TO CAUSE SEVERE PHYSICAL INJURY IN THE FORM OF SCALDING OR BURNS, EVEN WHEN THE HOT WATER TANK TEMPERATURE SETTING IS VISIBLY SET BELOW 150°F. THE 150°F HWG SETPOINT MUST ONLY BE USED ON SYSTEMS THAT EMPLOY AN APPROVED ANTI-SCALD VALVE (PART NUMBER AVAS4) AT THE HOT WATER STORAGE TANK WITH SUCH VALVE PROPERLY SET TO CONTROL WATER TEMPERATURES DISTRIBUTED TO ALL HOT WATER OUTLETS AT A TEMPERATURE LEVEL THAT PREVENTS SCALDING OR BURNS!

Figure 22: Anti-Scald Valve Piping Connections

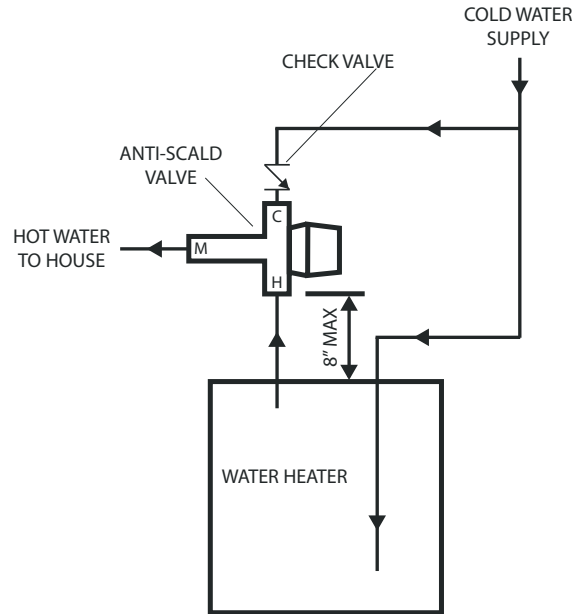

Hot Water Generator settings are determined by DIP switches 3-2, 3-3, and 3-4.

DIP 3-2 controls the HWG Test Mode. It provides for forced operation of the HWG output, activating the HWG pump for up to five minutes. ON = HWG test mode, OFF = normal HWG operation. The control will revert to standard operation after five minutes regardless of switch position.

DIP 3-3 determines HWG set point temperature. It provides for selection of the HWG operating set point. ON = 150°F (66°C), OFF = 125°F (52°C).

DIP 3-4 is for the HWG status. It provides HWG operation control. ON = HWG mode enabled, OFF = HWG mode disabled. Units are shipped from the factory with this switch in the OFF position.

Figure 23: Hot Water Generator Settings

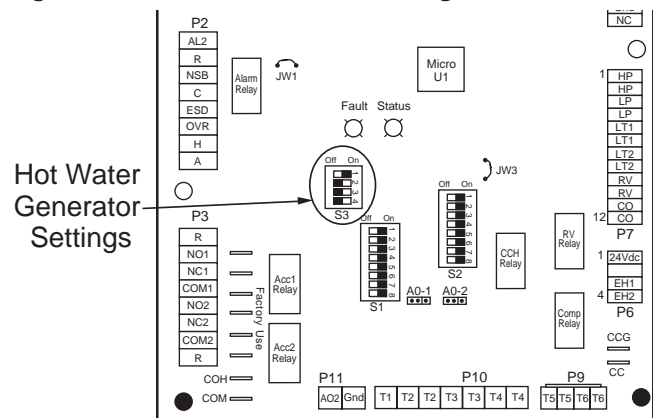

Hot Water Generator

⚠ WARNING! ⚠

WARNING! The HWG pump is fully wired from the factory. Use extreme caution when working around the microprocessor control as it contains line voltage connections that presents a shock hazard that can cause severe injury or death!

The heat pump, water piping, pump, and hot water tank should be located where the ambient temperature does not fall below 50°F [10°C]. Keep water piping lengths at a minimum. DO NOT use a one way length greater than 50 ft. (one way) [15 m]. See Table 6 for recommended piping sizes and maximum lengths.

All installations must be in accordance with local codes. The installer is responsible for knowing the local requirements, and for performing the installation accordingly. DO NOT activate the HWG (turn DIP 3-4 to the ON position) until “Initial Start-Up” section, below is completed. Powering the pump before all installation steps are completed will damage the pump.

Water Tank Preparation

1. Turn off power or fuel supply to the hot water tank.
2. Connect a hose to the drain valve on the water tank.
3. Shut off the cold water supply to the water tank.
4. Open the drain valve and open the pressure relief valve or a hot water faucet to drain tank.
5. When using an existing tank, it should be flushed with cold water after it is drained until the water leaving the drain hose is clear and free of sediment.
6. Close all valves and remove the drain hose.
7. Install HWG water piping.

HWG Water Piping

1. Using at least 1/2” [12.7mm] I.D. copper, route and install the water piping and valves as shown in Figures 21c or 21b. Install an approved anti-scald valve if the 150°F HWG setpoint is or will be selected. An appropriate method must be employed to purge air from the HWG piping. This may be accomplished by flushing water through the HWG (as in Figures 21a and 21b) or by installing an air vent at the high point of the HWG piping system.
2. Insulate all HWG water piping with no less than 3/8” [10mm] wall closed cell insulation.
3. Open both shut off valves and make sure the tank drain valve is closed.

Water Tank Refill

1. Close valve #4. Ensure that the HWG valves (valves #2 and #3) are open. Open the cold water supply (valve #1) to fill the tank through the HWG piping. This will force water flow through the HWG and purge air from the HWG piping.
2. Open a hot water faucet to vent air from the system until water flows from faucet; turn off faucet. Open valve #4.

3. Depress the hot water tank pressure relief valve handle to ensure that there is no air remaining in the tank.
4. Inspect all work for leaks.
5. Before restoring power or fuel supply to the water heater, adjust the temperature setting on the tank thermostat(s) to insure maximum utilization of the heat available from the refrigeration system and conserve the most energy. On tanks with both upper and lower elements and thermostats, the lower element should be turned down to 100°F [38°C] or the lowest setting; the upper element should be adjusted to 120-130°F [49-54°C]. Depending upon the specific needs of the customer, you may want to adjust the upper element differently. On tanks with a single thermostat, a preheat tank should be used (Fig 21b).
6. Replace access cover(s) and restore power or fuel supply.

Initial Start-Up

1. Make sure all valves in the HWG water circuit are fully open.
2. Turn on the heat pump and allow it to run for 10-15 minutes.
3. Set S3-4 to the “ON” position (enabled) to engage the HWG. See Figure *.
4. The HWG pump should not run if the compressor is not running.
5. The temperature difference between the water entering and leaving the HWG coil should be approximately 5-10°F [3-6°C].
6. Allow the unit to operate for 20 to 30 minutes to insure that it is functioning properly.

Table 6: HWG Water Piping Sizes and Length

Unit Nominal Tonnage	Nominal HWG Flow (gpm)	1/2" Copper (max length*)	3/4" Copper (max length*)
2.0	0.8	50	-
2.5	1.0	50	-
3.0	1.2	50	-
3.5	1.4	50	-
4.0	1.6	45	50
5.0	2.0	25	50
6.0	2.4	10	50

*Maximum length is equivalent length (in feet) one way of type L copper.

⚠ CAUTION! ⚠

CAUTION! Use only copper piping for HWG piping due to the potential of high water temperatures for water that has been in the HWG heat exchanger during periods of no-flow conditions (HWG pump not energized). Piping other than copper may rupture due to high water temperature and potable water pressure.

Electrical - Line Voltage

⚠ WARNING! ⚠

WARNING! To avoid possible injury or death due to electrical shock, open the power supply disconnect switch and secure it in an open position during installation.

⚠ CAUTION! ⚠

CAUTION! Use only copper conductors for field installed electrical wiring. Unit terminals are not designed to accept other types of conductors.

Table 7a: GT-PB (50YF) Series Electrical Data with Magna Internal Flow Controller

Model	Compressor			HWG Pump FLA	Int Loop Pump FLA	Fan Motor FLA	Total Unit FLA	Min Circuit Amps	Max Fuse/HACR
	RLA	LRA	Qty						
024	11.7	58.3	1	0.5	1.7	3.9	17.8	20.7	30
030	13.1	73.0	1	0.5	1.7	3.9	19.2	22.4	35
036	15.3	83.0	1	0.5	1.7	3.9	21.4	25.2	40
042	17.9	96.0	1	0.5	1.7	5.2	25.3	29.7	45
048	21.2	104.0	1	0.5	1.7	5.2	28.6	33.9	50
060	27.1	152.9	1	0.5	1.7	6.9	36.2	42.9	70

Rated Voltage of 208-230/60/1
HACR circuit breaker in USA only

Min/Max Voltage of 197/254
All fuses Class RK-5

Table 7b: GT-PB (50YF) Series Electrical Data with Modulating Valve

Model	Compressor			HWG Pump FLA	Fan Motor FLA	Total Unit FLA	Min Circuit Amps	Max Fuse/HACR
	RLA	LRA	Qty					
024	11.7	58.3	1	0.5	3.9	16.1	19.0	30
030	13.1	73.0	1	0.5	3.9	17.5	20.7	30
036	15.3	83.0	1	0.5	3.9	19.7	23.5	35
042	17.9	96.0	1	0.5	5.2	23.6	28.0	45
048	21.2	104.0	1	0.5	5.2	26.9	32.2	50
060	27.1	152.9	1	0.5	6.9	34.5	41.2	60

Rated Voltage of 208-230/60/1
HACR circuit breaker in USA only

Min/Max Voltage of 197/254
All fuses Class RK-5

Electrical - Line Voltage

All field installed wiring, including electrical ground, must comply with the National Electrical Code as well as all applicable local codes. Refer to the unit electrical data for fuse sizes. Consult wiring diagram for field connections that must be made by the installing (or electrical) contractor.

All final electrical connections must be made with a length of flexible conduit to minimize vibration and sound transmission to the building.

General Line Voltage Wiring

Be sure the available power is the same voltage and phase shown on the unit serial plate. Line and low voltage wiring must be done in accordance with local codes or the National Electric Code, whichever is applicable.

Power Connection

Line voltage connection is made by connecting the incoming line voltage wires to the "L" side of the contactor as shown in Figure 21. Consult Tables 7a through 7b for correct fuse size.

208 Volt Operation

All residential 208-230 Volt units are factory wired for 230 Volt operation. The transformer may be switched to the 208V tap as illustrated on the wiring diagram by switching the red (208V) and the orange (230V) wires at the contactor terminal.

Figure 24: GT-PB Single Phase Line Voltage Field Wiring

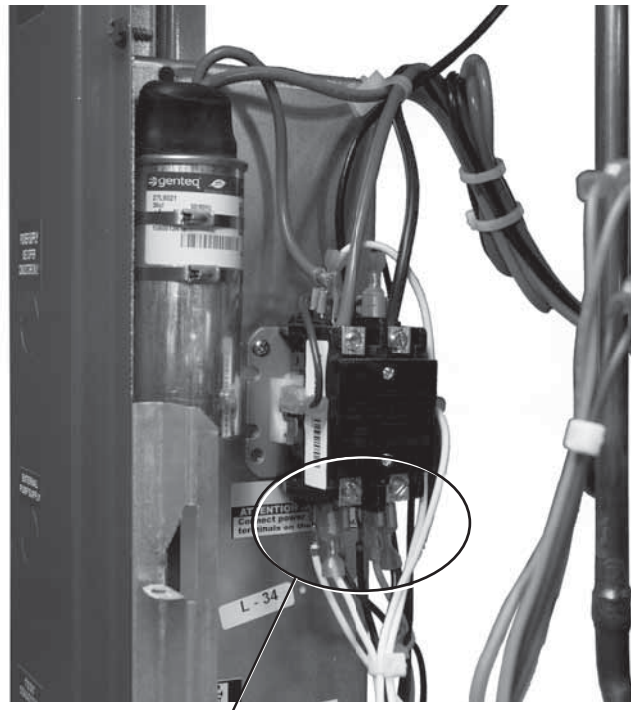

Unit Power Supply
(see electrical tables 7a - 7b for minimum circuit amps and maximum breaker size)

Electrical - Low Voltage Wiring

Figure 25: GT-PB Low Voltage Field Wiring

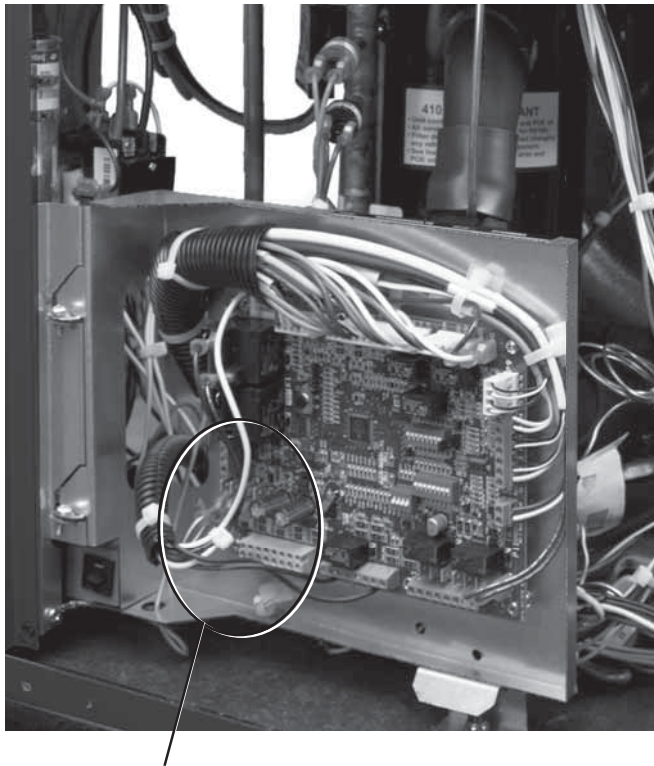

Low Voltage Field Wiring

Accessory Connections

A terminal paralleling the compressor contactor coil has been provided on the DXM2 control. Terminal “A” is designed to control accessory devices. Note: This terminal should be used only with 24 Volt signals and not line voltage. Terminal “A” is energized with the compressor contactor (see Figure 26).

The DXM2 controller includes two accessory relays ACC1 and ACC2. Each relay includes a normally open (NO) and a normally closed (NC) contact. Accessory relays may be configured to operate as shown in Tables 8a and 8b.

Table 8a: Accessory Relay 1 Configuration

DIP 2.1	DIP 2.2	DIP 2.3	ACC1 Relay Option
ON	ON	ON	Cycle with fan
OFF	ON	ON	N/A for Residential Applications
ON	OFF	ON	Water valve – Slow opening
ON	ON	OFF	Outside air damper
OFF	ON	OFF	Whole House Dehumidification option – Dehumidistat
OFF	OFF	OFF	Whole House Dehumidification option – Humidistat
OFF	OFF	ON	N/A for Residential Applications
ON	OFF	OFF	N/A for Residential Applications

All other DIP combinations are invalid

Table 8b: Accessory Relay 2 Configuration

DIP 2.4	DIP 2.5	DIP 2.6	ACC2 Relay Option
ON	ON	ON	Cycle with compressor
OFF	ON	ON	N/A for Residential Applications
ON	OFF	ON	Water valve – Slow opening
OFF	OFF	ON	Humidifier
ON	ON	OFF	Outside air damper

All other DIP combinations are invalid

Figure 26: Accessory Connections

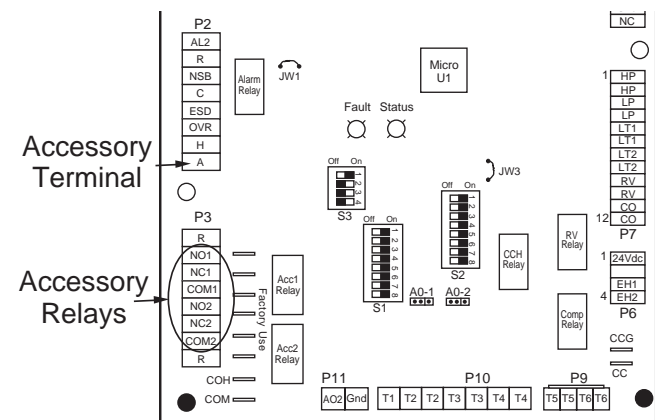

Electrical - Thermostat Wiring

Thermostat Installation

The thermostat should be located on an interior wall in a larger room, away from supply duct drafts. DO NOT locate the thermostat in areas subject to sunlight, drafts or on external walls. The wire access hole behind the thermostat may in certain cases need to be sealed to prevent erroneous temperature measurement. Position the thermostat back plate against the wall so that it appears level and so the thermostat wires protrude through the middle of the back plate. Mark the position of the back plate mounting holes and drill holes with a 3/16" (5mm) bit. Install supplied anchors and secure plate to the wall. Thermostat wire must be 18 AWG wire. Wire the appropriate thermostat as shown in Figures 24a and 24b to the low voltage terminal strip on the DXM2 control board. Practically any heat pump thermostat will work with these units, provided it has the correct number of heating and cooling stages. However, using the communicating thermostat (ATC32) is highly recommended for on-site, easier configuration, monitoring and diagnosis.

⚠ CAUTION! ⚠

CAUTION! Refrigerant pressure activated water regulating valves should never be used.

⚠ CAUTION! ⚠

CAUTION! If communicating thermostat is not installed, a communicating service tool must be used to configure and diagnose this system.

Figure 27: Communication Flow

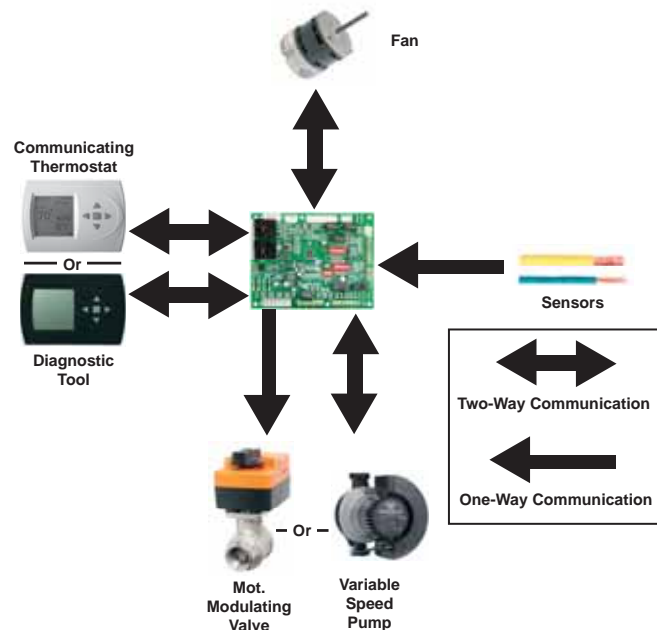

Figure 28a: Communicating Thermostat Connection to DXM2 Control

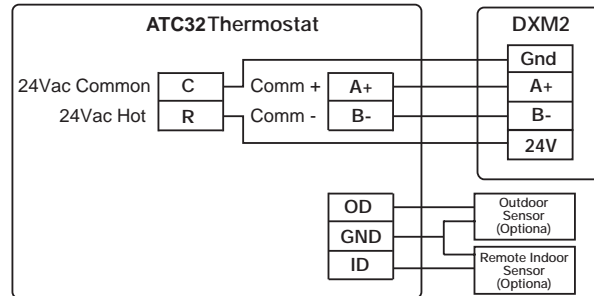
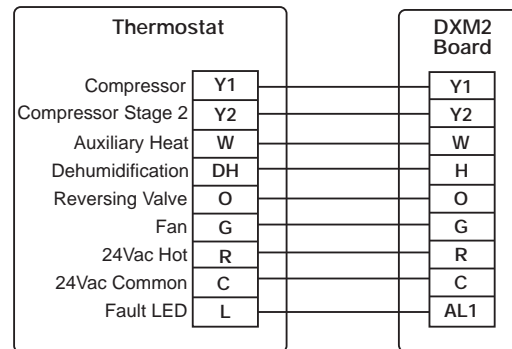

Figure 28b: Conventional 3 Heat / 2 Cool Thermostat Connection to DXM2 Control



Notes:

- 1) ECM automatic dehumidification mode operates with dehumidification airflows in the cooling mode when the dehumidification output from thermostat is active. Normal heating and cooling airflows are not affected.
- 2) DXM2 board DIP switch S2-7 must be in the auto dehumidification mode for automatic dehumidification
- 3) DH connection not possible with units with internal pump. Use ATC32U**.
- 4) Only use ATC Communicating Thermostat when using Humidifier (H Input) with units with internal flow controller.

Auxiliary Heat Installation

In both vertical and horizontal configurations, auxiliary electric heater is installed externally to the unit.

For installation instructions, refer to the Electric Heat IOM, 97B0005N03.

Typical Vertical External Mount Installation

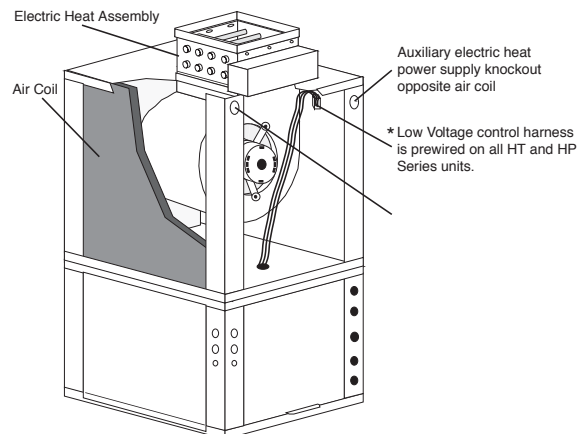

DXM2 Wiring Diagram with Internal Flow Controller - 96B0005N60

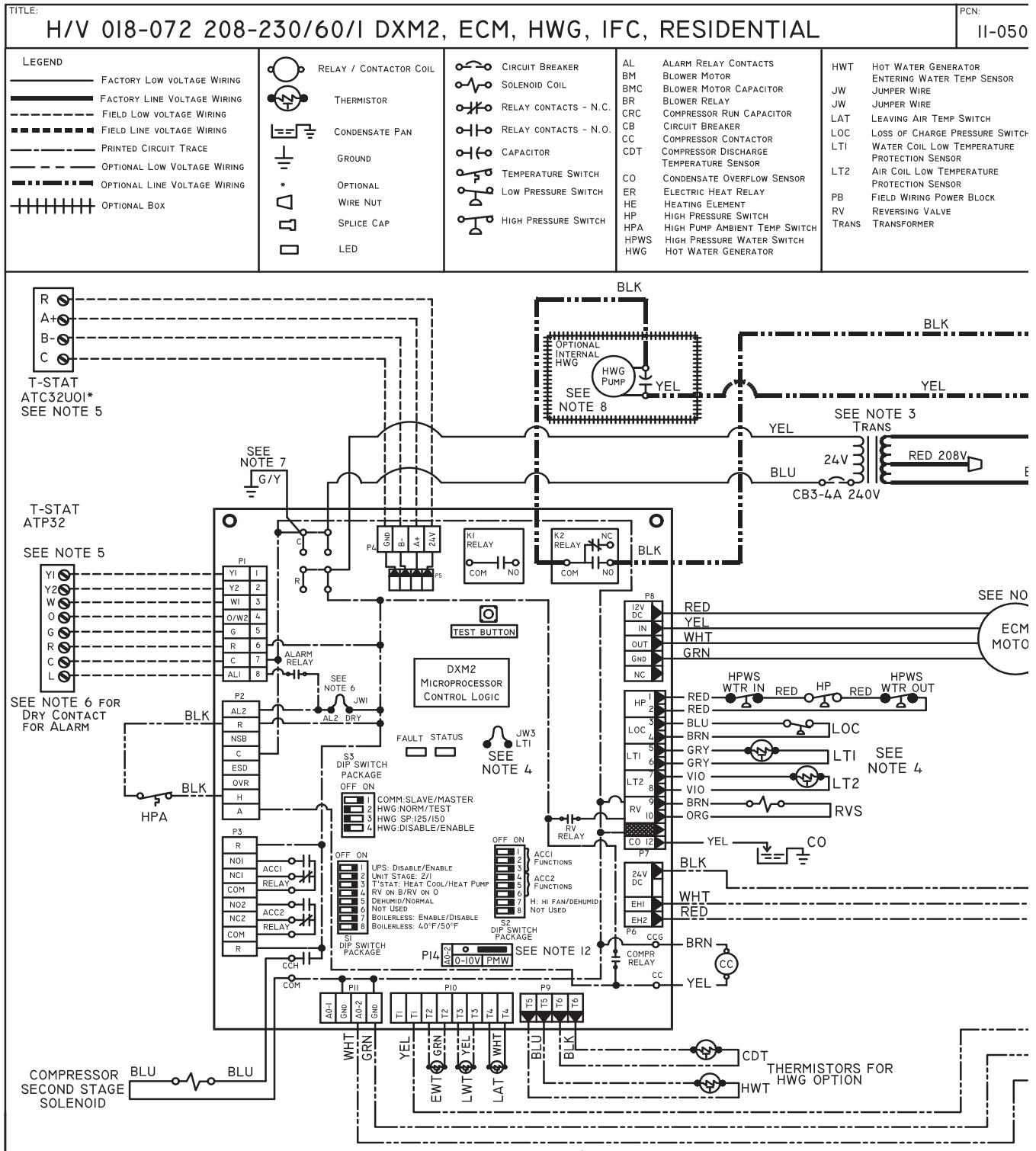

This diagram includes typical wiring details but is not applicable to all units. For specific unit wiring, refer to the diagram or the units' control panel.

DXM2 Wiring Diagram with Internal Flow Controller - 96B0005N60

2	DATE: 9/26/11		DRAWING NO: 96B0005N60	REV: A
---	------------------	---	---------------------------	-----------

NOTES:

1. Compressor and Blower Motor thermally protected internally.
2. All wiring to the unit must comply with NEC and local codes.
3. 208/230V transformer will be connected for 230V operation.
For 208V operation, disconnect ORG lead at L1, and attach RED lead to L1. Insulate open end of ORG lead.
4. LTI Thermistor provides low temperature protection for WATER. When using ANTIFREEZE solutions, cut JW3 jumper.
5. Refer to TSTAT Installation, Application, and Operation Manual for Control Wiring to the unit.
Low voltage Wiring must be "CLASS 1" and voltage rated Equal or Greater Than Unit Supply Voltage.
6. 24V Alarm signal at AL1. For Dry Contact between AL1 & AL2, cut JW1.
7. Transformer secondary ground via CXM/DXM board standoffs & screws to Control Box.
(Ground available from top two standoffs as shown.)
8. HWG and Heat Exchanger pump only in models with Hot Water Generator option.
Factory default Temperature setting is 125F, for 150F setting Anti-Scald Valve must be used, see unit IOM for instructions.
9. For ECM Blower Motor air flow adjustment and diagnostic information refer to unit IOM.
10. For auxiliary staging options, consult electric heat installation manual.
11. For Variable Speed pump control and diagnostic information refer to unit IOM.
12. For Variable Speed pump option, place jumper on PMW pins.

CONTROL BOX LAYOUT

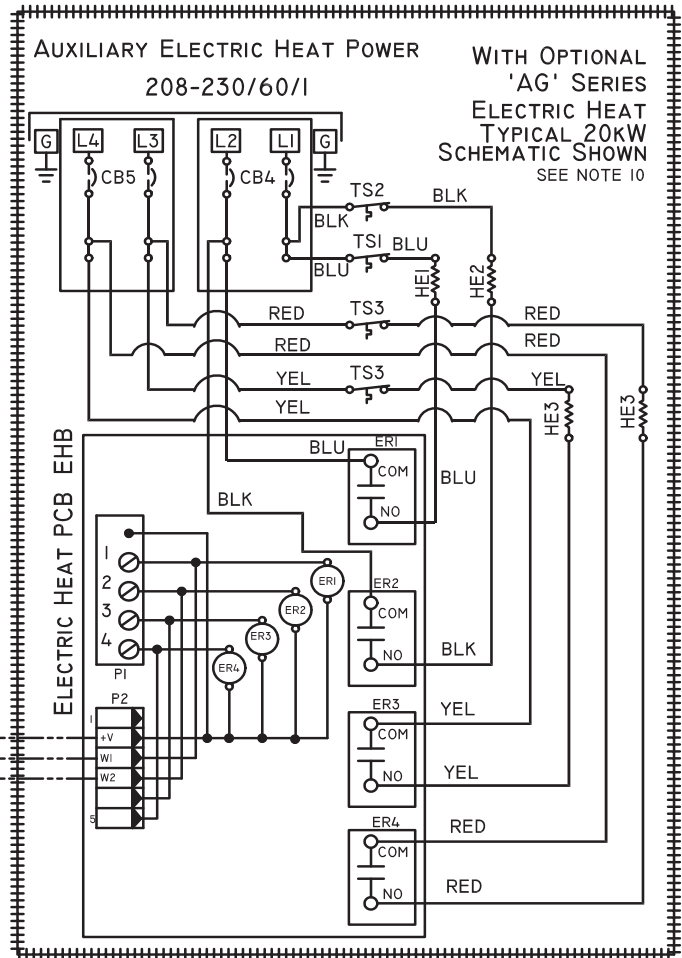
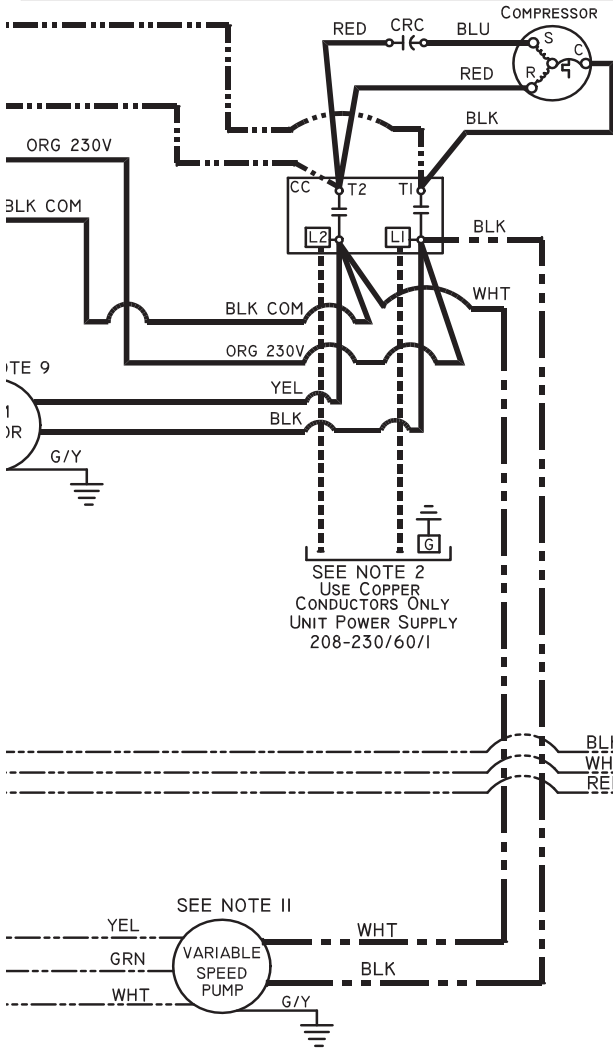
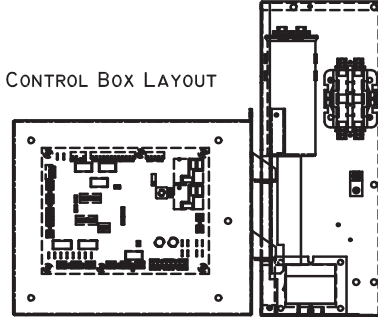

This diagram includes typical wiring details but is not applicable to all units. For specific unit wiring, refer to the diagram or the units' control panel.

DXM2 Wiring Diagram with Motorized Modulating Water Valve - 96B0005N62

TITLE: **H/V 018-072 208-230/60/1 DXM2, ECM, HWG, MWV, RESIDENTIAL** PCN: **12-018**

LEGEND		RELAY / CONTACTOR COIL		CIRCUIT BREAKER		AL		JW	
—	FACTORY LOW VOLTAGE WIRING		RELAY / CONTACTOR COIL		CIRCUIT BREAKER	AL	ALARM RELAY CONTACTS	JW	JUMPER WIRE
—	FACTORY LINE VOLTAGE WIRING		THERMISTOR		SOLENOID COIL	BM	BLOWER MOTOR	LAT	LEAVING AIR TEMP SENSOR
- - -	FIELD LOW VOLTAGE WIRING		CONDENSATE PAN		RELAY CONTACTS - N.C.	CRC	COMPRESSOR RUN CAPACITOR	LOC	LOSS OF CHARGE PRESSURE SWITCH
---	FIELD LINE VOLTAGE WIRING		GROUND		RELAY CONTACTS - N.O.	CB	CIRCUIT BREAKER	LTI	WATER COIL LOW TEMPERATURE PROTECTION SENSOR
---	PRINTED CIRCUIT TRACE		OPTIONAL		CAPACITOR	CC	COMPRESSOR CONTACTOR	LT2	AIR COIL LOW TEMPERATURE PROTECTION SENSOR
- - -	OPTIONAL LOW VOLTAGE WIRING		WIRE NUT		TEMPERATURE SWITCH	CDT	COMPRESSOR DISCHARGE TEMPERATURE SENSOR	MWV	MODULATING WATER VALVE
---	OPTIONAL LINE VOLTAGE WIRING		SPLICE CAP		LOW PRESSURE SWITCH	CO	CONDENSATE OVERFLOW SENSOR	RV	REVERSING VALVE
---	OPTIONAL BOX		LED		HIGH PRESSURE SWITCH	ER	ELECTRIC HEAT RELAY	TRANS	TRANSFORMER
						HE	HEATING ELEMENT		
						HP	HIGH PRESSURE SWITCH		
						HPWS	HIGH PRESSURE WATER SWITCH		
						HWG	HOT WATER GENERATOR		
						HWT	HOT WATER GENERATOR ENTERING WATER TEMP SENSOR		

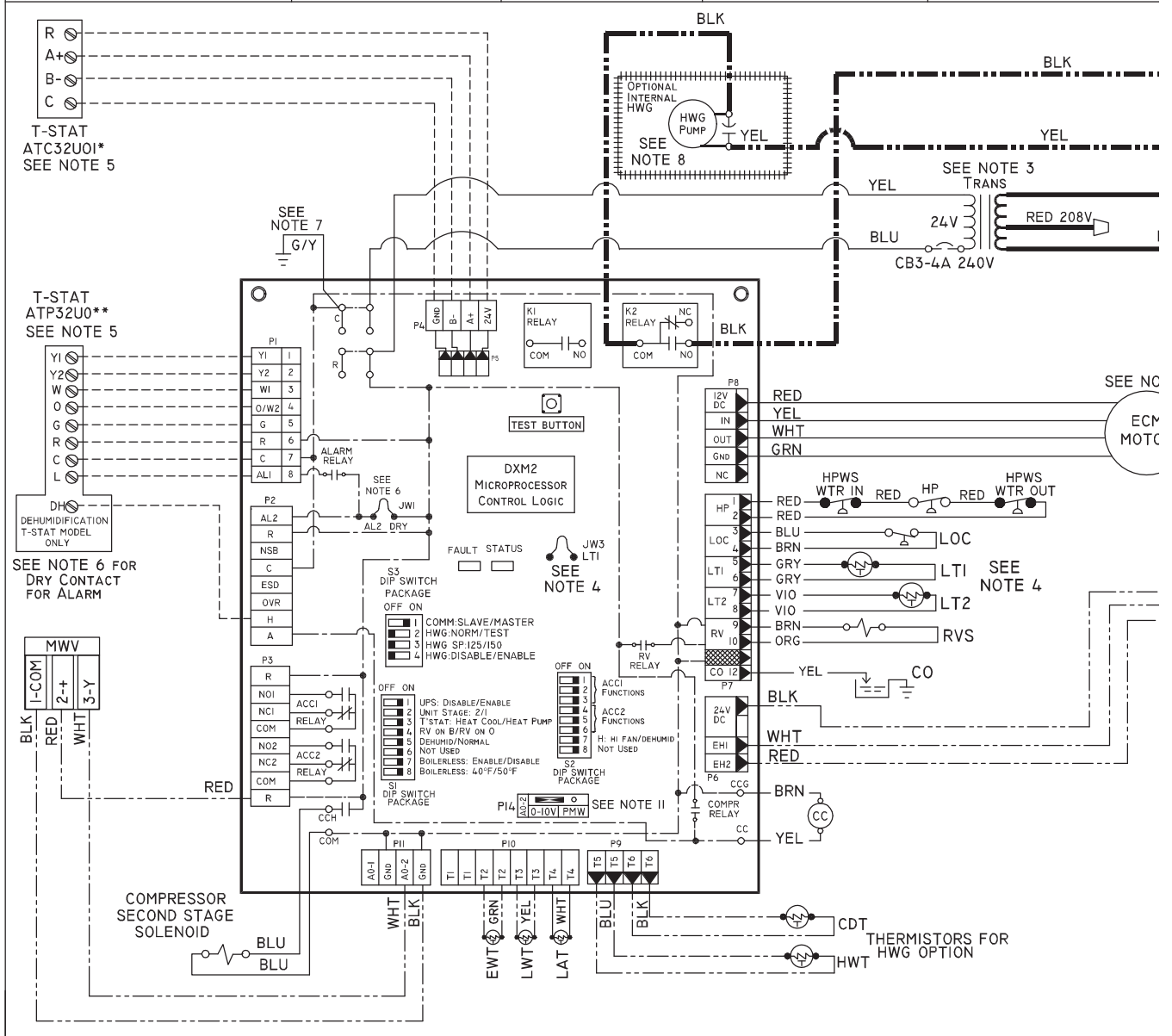

This diagram includes typical wiring details but is not applicable to all units. For specific unit wiring, refer to the diagram or the units' control panel.

DXM2 Wiring Diagram with Motorized Modulating Water Valve - 96B0005N62

8	DATE: 4/19/12		DRAWING NO: 96B0005N62	REV: C
---	------------------	--	----------------------------------	------------------

- NOTES:**
1. Compressor and Blower Motor thermally protected internally.
 2. All wiring to the unit must comply with NEC and local codes.
 3. 208/230V transformer will be connected for 230V operation.
For 208V operation, disconnect ORG lead at L1, and attach RED lead to L1. Insulate open end of ORG lead.
 4. LT1 Thermistor provides low temperature protection for WATER. When using ANTIFREEZE solutions, cut JW3 jumper.
 5. Refer to TSTAT Installation, Application, and Operation Manual for Control Wiring to the unit.
Low voltage Wiring must be "CLASS 1" and voltage rated Equal or Greater Than Unit Supply Voltage.
 6. 24V Alarm signal at AL1. For Dry Contact between AL1 & AL2, cut JW1.
 7. Transformer secondary ground via CXM/DXM board standoffs & screws to Control Box.
(Ground available from top two standoffs as shown.)
 8. HWG and Heat Exchanger pump only in models with Hot Water Generator option.
Factory default Temperature setting is 125F, for 150F setting Anti-Scald Valve must be used, see unit IOM for instructions.
 9. For ECM Blower Motor air flow adjustment and diagnostic information refer to unit IOM.
 10. For auxiliary staging options, consult electric heat installation manual.
 11. For MWV option, place jumper on 0-10V pins.
 12. For MWV option, ensure actuator direction switch is set as shown.

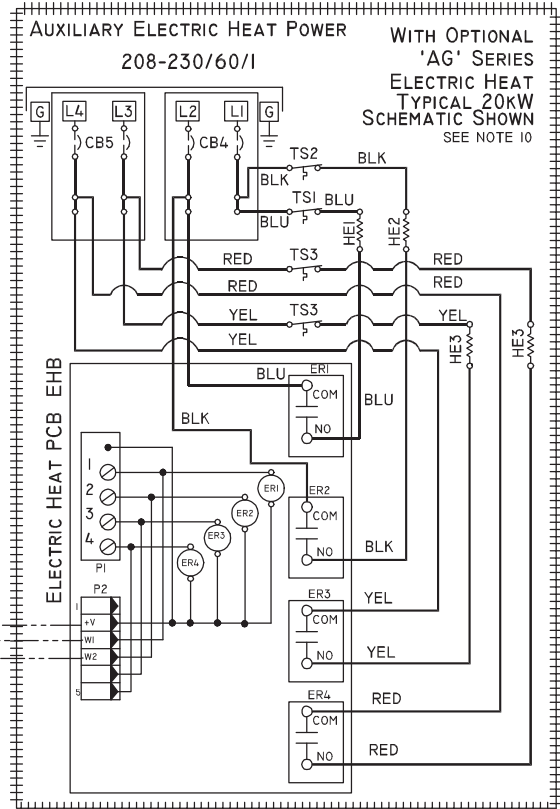
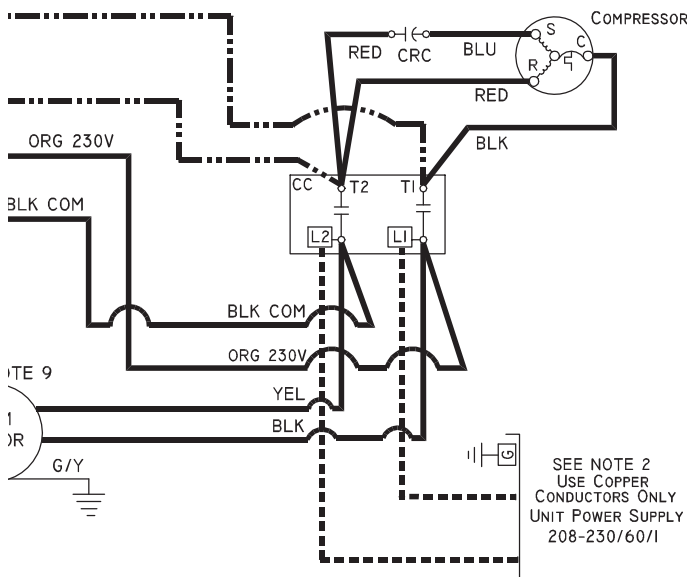
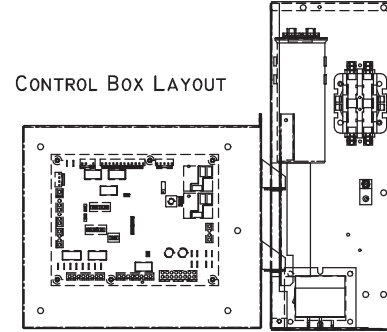

SEE NOTE 12

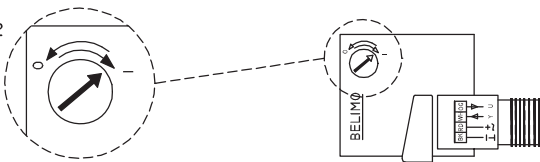

SEE NOTE 12

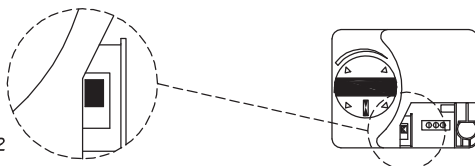

This diagram includes typical wiring details but is not applicable to all units. For specific unit wiring, refer to the diagram or the units' control panel.

ECM Blower Control

The ECM fan is controlled directly by the DXM2 control board that converts thermostat inputs and CFM settings to signals used by the ECM motor controller. To take full advantage of the ECM motor features, a Two-Way Unit Communicating System communicating multi-stage thermostat should be used (ATC32U**).

The DXM2 control maintains a selectable operating airflow [CFM] for each heat pump operating mode. For each operating mode there are maximum and minimum airflow limits. See the ECM Blower Performance tables for the maximum, minimum, and default operating airflows.

Airflow levels are selected using the configuration menus of a communicating thermostat (ATC32U**) or diagnostic tool (ACDU**). The configuration menus allow the installer to independently select and adjust the operating airflow for each of the operating modes. Air flow can be selected in 25 CFM increments within the minimum and maximum limits shown in Table 9. The blower operating modes include:

- First Stage Cooling (Y1 & O)
- Second Stage Cooling (Y1, Y2, & O)
- First Stage Cooling in Dehumidification Mode (Y1, O, & Dehumid)
- Second Stage Cooling in Dehumidification Mode (Y1, Y2, O, & Dehumid)
- First Stage Heating (Y1)
- Second Stage Heating (Y1 & Y2)
- Third Stage (Auxiliary) Heating (Y1, Y2, & W)
- Emergency Heating (W with no Y1 or Y2)
- Fan (G with no Y1, Y2, or W)

It is necessary to use the ATC32U** communicating thermostat to engage the Auto Dehumidification feature on units with Internal Flow Controllers. Units with Internal Flow Controllers utilize the 'H' terminal on the DXM2 as an input for an ambient temperature switch. Units without the Internal Flow Controller option use the 'H' terminal on the DXM2 controller to initiate the Auto Dehumidification mode. Refer to the DXM2 AOM for more information (part #97B0003N15).

The ECM motor includes “soft start” and “ramp down” features. The soft start feature is a gentle increase of motor rpm at blower start up. This creates a much quieter blower start cycle.

The ramp down feature allows the blower to slowly decrease rpm to a full stop at the end of each blower cycle. This creates a much quieter end to each blower cycle and adds overall unit efficiency.

The ramp down feature is eliminated during an ESD (Emergency Shut Down) situation. When the DXM2 ESD input is activated, the blower and all other control outputs are immediately de-activated.

The duration of the “ramp down” periods are adjustable from 0 seconds to 255 seconds. This adjustment is available in the Aiflow Selection screen using the communicating thermostat or configuration/diagnostics tool, see Figure 27.

Special Note for AHRI Testing: To achieve rated airflow for AHRI testing purposes, it is necessary to change the CFM settings to rated airflow.

Figure 29: Airflow Configuration Screen on Communicating Thermostat

AIRFLOW SELECTION	
	CFM
HEAT STAGE 1	600
HEAT STAGE 2	750
AUXILIARY HEAT	850
EMERGENCY HEAT	850
COOL STAGE 1	525
COOL STAGE 2	700
COOL DEHUMID 1	425
COOL DEHUMID 2	550
CONTINUOUS FAN	350
HEAT OFF DELAY	60
COOL OFF DELAY	30
◀ PREVIOUS	NEXT ▶

ECM Blower Performance Data

Table 9: GT-PB (50YF) Series ECM Blower Performance Data Table

Airflow in CFM with wet coil and clean air filter

Model	Max ESP (in. wg)	Fan Motor (hp)	Range	Cooling Mode		Dehumid Mode		Heating Mode		Fan Only Mode	Aux/ Emerg Mode
				Stg 2	Stg 1	Stg 2	Stg 1	Stg 2	Stg 1		
024	0.75	1/2	Default	750	575	650	500	750	575	350	750
			Maximum	850	650	800	600	850	850	850	850
			Minimum	600	450	600	450	600	450	300	650
030	0.5	1/2	Default	950	650	800	575	950	650	450	950
			Maximum	1100	750	1000	700	1100	1100	1100	1100
			Minimum	750	525	750	525	750	525	375	750
036	0.6	1/2	Default	1125	750	975	650	1125	750	525	1125
			Maximum	1250	950	1200	800	1250	1250	1250	1250
			Minimum	900	600	900	600	900	600	450	900
042	0.6	3/4	Default	1300	925	1125	825	1300	925	600	1300
			Maximum	1475	1100	1400	1000	1475	1475	1475	1475
			Minimum	1050	750	1050	750	1050	750	525	1050
048	0.75	3/4	Default	1500	1125	1300	975	1500	1125	700	1500
			Maximum	1700	1300	1600	1200	1700	1700	1700	1700
			Minimum	1200	900	1200	900	1200	900	600	1350
060	0.75	1	Default	1875	1500	1625	1300	1875	1500	875	1875
			Maximum	2100	1700	2000	1600	2100	2100	2100	2100
			Minimum	1500	1200	1500	1200	1500	1200	750	1500

Airflow is controlled within 5% up to the Max ESP shown with wet coil
 Factory shipped on default CFM

DXM2 Controls

DXM2 Controller DXM2 is the next generation in controls and is capable of 2-way communication with smart components, like the communicating thermostat, ECM fan motor, Magna Variable-Speed Pump and configuration/ diagnostic tool.

For most residential applications, configuration, monitoring and diagnostics can all be done from the thermostat/ service tool so there's no need to read LEDs and change DIP switches.

For details on user settings, refer to ATC32U01A Communicating Thermostat User Manual (part # 97B0055N06).

For details on Installer settings (not to be used by consumers), refer to ATC32U01A Communicating Thermostat Installer manual (part # 97B0055N07).

For details on installer/service settings on the ACDU01A configuration/diagnostic tool, refer to operation manual (part # 97B0106N02).

For further details on the DXM2 control, refer to the DXM2 Application, Operation and Maintenance Manual (part # 97B0003N15). The DXM2 AOM is shipped with each unit.

Thermostat compatibility

It is strongly recommended that communicating thermostat (ATC32U**) or configuration/ diagnostic tool (ACDU**) be used with DXM2 control, to ensure easy configuration, monitoring and diagnostics, in PLAIN English. For example, Airflow CAN NOT be configured without either the communicating thermostat or configuration/ diagnostic tool

Field Hardware Configuration Options - Note: In the following field hardware configuration options, changes should be made ONLY when power is removed from the DXM2 control.

Water coil low temperature limit setting: Jumper 3 (JW3-LT1 Low Temp) provides field selection of temperature limit setting for LT1 of 30°F or 10°F [-1°F or -12°C] (refrigerant temperature).

Not Clipped = 30°F [-1°C]. Clipped = 10°F [-12°C].

A0-2: Configure Modulating Valve or Variable-Speed Pump (Internal water flow Models Only)

A0-2 jumper (Figure 32) Factory Set to "IOV" if using Internal Modulating Motorized Valve or "PMW" if using Internal Variable-Speed Pump. This applies only to units with Internal Water Flow Control.

DIP Switches – There's no need to change the DIP switches settings on Residential units. All DIP switches in S1 and S2 should be "on". In S3, S3-1 should be "on" and the rest should be "off". For more details on DIP switches, refer to the DXM2 AOM (part # 97B0003N15).

DXM2 Control Start-up Operation

The control will not operate until all inputs and safety controls are checked for normal conditions. The compressor will have a 5 minute anti-short cycle delay at power-up. The first time after power-up that there is a call for compressor, the compressor will follow a 5 to 80 second random start delay.

After the random start delay and anti-short cycle delay, the compressor relay will be energized. On all subsequent compressor calls, the random start delay is omitted.

Test Mode Button

Test mode allows the service technician to check the operation of the control in a timely manner. By momentarily pressing the TEST push button, the DXM2 control enters a 20 minute test mode period in which all time delays are sped up 15 times.

Figure 30: Test Mode Button

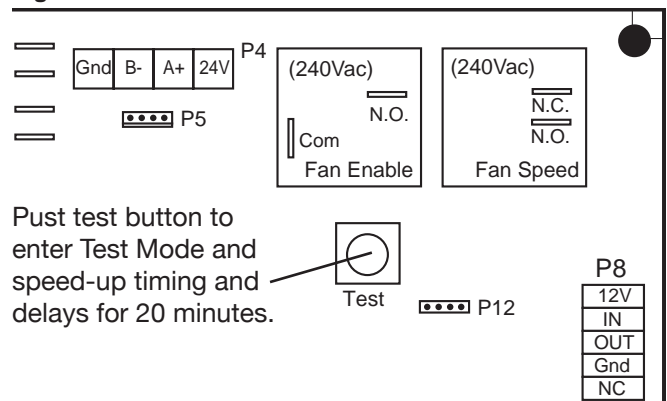

Push test button to enter Test Mode and speed-up timing and delays for 20 minutes.

Table 10: Unit Operation

Conventional T-stat signal (Non-Communicating)	Unit
	ECM fan
G	Fan only
G, Y1	Stage 1 heating ¹
G, Y1, Y2	Stage 2 heating ¹
G, Y1, Y2, W	Stage 3 heating ¹
G, W	Emergency heat
G, Y1, O	Stage 1 cooling ²
G, Y1, Y2, O	Stage 2 cooling ²

- 1 Stage 1 = 1st stage compressor, 1st stage fan operation
 Stage 2 = 2nd stage compressor, 2nd stage fan operation
 Stage 3 = 2nd stage compressor, auxiliary electric heat, 3rd stage fan operation
- 2 Stage 1 = 1st stage compressor, 1st stage fan operation, reversing valve
 Stage 2 = 2nd stage compressor, 2nd stage fan operation, reversing valve

▲ CAUTION! ▲

CAUTION! Do not restart units without inspection and remedy of faulting condition. Equipment damage may occur.

DXM2 Layout and Connections

Low Water Temperature Cutout Selection

The DXM2 control allows the field selection of low water (or water-antifreeze solution) temperature limit by clipping jumper JW3, which changes the fault cutout temperature associated with thermistor LT1. Note that the LT1 thermistor is located on the refrigerant line between the coaxial heat exchanger and expansion device (TXV). Therefore, LT1 is sensing refrigerant temperature, not water temperature, which is a better indication of how water flow rate/temperature is affecting the refrigeration circuit.

The factory setting for LT1 is for systems using water (30°F [-1.1°C] refrigerant temperature cutout or fallout). In low water temperature (extended range) applications with antifreeze (most ground loops), jumper JW3 should be clipped as shown in Figure 31 to change the setting to 10°F [-12.2°C] refrigerant cutout or fallout temperature, a more suitable temperature when using an antifreeze solution. All residential units include

water/refrigerant circuit insulation to prevent internal condensation, which is required when operating with entering water temperatures below 59°F [15°C].

Figure 31: LT1 Limit Setting

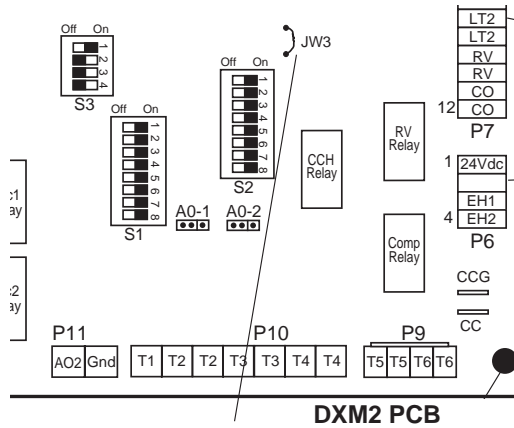

JW3-LT1 jumper should be clipped for low temperature (antifreeze) operation

Figure 32: DXM2 Layout and Connections

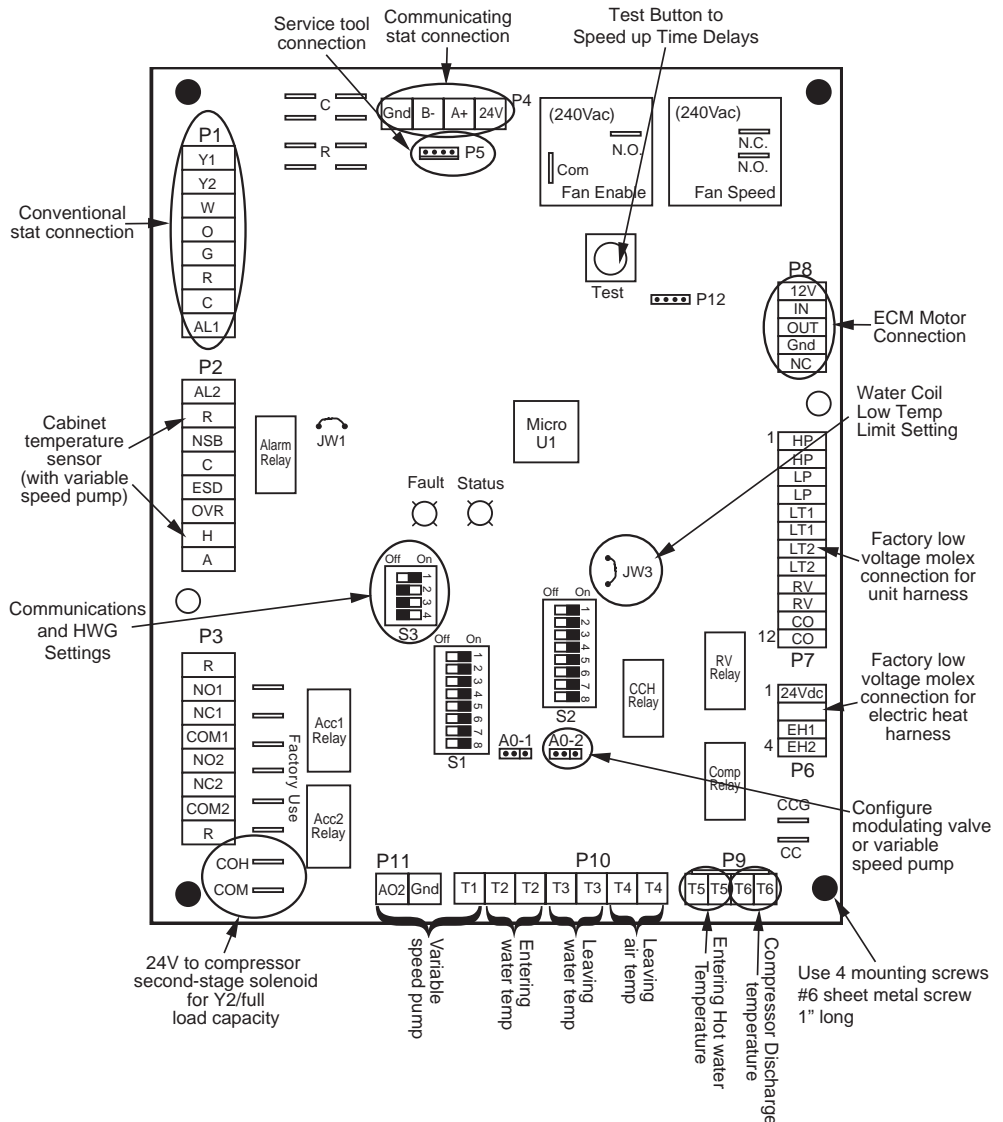

Unit Commissioning and Operating Conditions

Operating Limits

Environment – Units are designed for indoor installation only. Never install units in areas subject to freezing or where humidity levels could cause cabinet condensation (such as unconditioned spaces subject to 100% outside air).

Power Supply – Voltage utilization shall comply with AHRI standard 110.

Determination of operating limits is dependent primarily upon three factors: 1) return air temperature. 2) water temperature, and 3) ambient temperature. When any one of these factors is at minimum or maximum levels, the other two factors should be at normal levels to insure proper unit operation. Extreme variations in temperature and humidity and/or corrosive water or air will adversely affect unit performance, reliability, and service life. Consult Table 9a for operating limits.

Table 11a: Building Operating Limits

Operating Limits	Unit	
	Cooling	Heating
Air Limits		
Min. ambient air, DB	45°F [7°C]	39°F [4°C]
Rated ambient air, DB	80.6°F [27°C]	68°F [20°C]
Max. ambient air, DB	130°F [54°C]	85°F [29°C]
Min. entering air, DB/WB	65/45°F [18/7°C]	50°F [10°C]
	70/50°F Reheat	
Rated entering air, DB/WB	80.6/66.2°F [27/19°C]	68°F [20°C]
Max. entering air, DB/WB	100/75°F [38/24°C]	80°F [27°C]
Water Limits		
Min. entering water	20°F [-6.7°C]	20°F [-6.7°C]
Normal entering water	50-110°F [10-43°C]	30-70°F [-1 to 21°C]
Max. entering water	120°F [49°C]	120°F [49°C]
Normal Water Flow	1.5 to 3.0 gpm / ton [1.6 to 3.2 l/m per kW]	

Commissioning Conditions

Consult Table 11b for commissioning conditions. Starting conditions vary depending upon model and are based upon the following notes:

Notes:

- Conditions in Table 11b are not normal or continuous operating conditions. Minimum/maximum limits are start-up conditions to bring the building space up to occupancy temperatures. Units are not designed to operate under these conditions on a regular basis.
- Voltage utilization complies with AHRI Standard 110.

Table 11b: Building Commissioning Limits

Commissioning Limits	Unit	
	Cooling	Heating
Air Limits		
Min. ambient air, DB	45°F [7°C]	39°F [4°C]
Rated ambient air, DB	80.6°F [27°C]	68°F [20°C]
Max. ambient air, DB	130°F [54°C]	85°F [29°C]
Min. entering air, DB/WB	60°F [16°C]	40°F [4.5°C]
Rated entering air, DB/WB	80.6/66.2°F [27/19°C]	68°F [20°C]
Max. entering air, DB/WB	110/83°F [43/28°C]	80°F [27°C]
Water Limits		
Min. entering water	20°F [-6.7°C]	20°F [-6.7°C]
Normal entering water	50-110°F [10-43°C]	30-70°F [-1 to 21°C]
Max. entering water	120°F [49°C]	120°F [49°C]
Normal Water Flow	1.5 to 3.0 gpm / ton [1.6 to 3.2 l/m per kW]	

Unit Start-Up and Operating Conditions

Unit and System Checkout

BEFORE POWERING SYSTEM, please check the following:

UNIT CHECKOUT

- Shutoff valves: Insure that all isolation valves are open.
- Line voltage and wiring: Verify that voltage is within an acceptable range for the unit and wiring and fuses/ breakers are properly sized. Verify that low voltage wiring is complete.
- Unit control transformer: Insure that transformer has the properly selected voltage tap. Residential 208-230V units are factory wired for 230V operation unless specified otherwise.
- Loop/water piping is complete and purged of air. Water/ piping is clean.
- Antifreeze has been added if necessary.
- Entering water and air: Insure that entering water and air temperatures are within operating limits of Tables 10a and 10b.
- Low water temperature cutout: Verify that low water temperature cut-out on the DXM2 control is properly set.
- Unit fan: Manually rotate fan to verify free rotation and insure that blower wheel is secured to the motor shaft. Be sure to remove any shipping supports if needed. DO NOT oil motors upon start-up. Fan motors are pre-oiled at the factory. Check unit fan CFM selection and compare to design requirements.
- Condensate line: Verify that condensate trap is installed and pitched.
- HWG is switched off at SW 3-4 unless piping is completed and air has been purged from the system.
- Unit air coil and filters: Insure that filter is clean and accessible. Clean air coil of all manufacturing oils.
- Unit controls: Verify that DXM2 field selection options are properly set. Low voltage wiring is complete.
- Blower CFM and Water ΔT is set on communicating thermostats or diagnostic tool.
- Service/access panels are in place.

SYSTEM CHECKOUT

- System water temperature: Check water temperature for proper range and also verify heating and cooling set points for proper operation.
- System pH: Check and adjust water pH if necessary to maintain a level between 6 and 8.5. Proper pH promotes system longevity (see Table 5).
- System flushing: Verify that all air is purged from the system. Air in the system can cause poor operation or system corrosion. Water used in the system must be potable quality initially and clean of dirt, piping slag, and strong chemical cleaning agents. Some antifreeze solutions may require distilled water.
- Internal Flow Controller: Verify that it is purged of air and in operating condition.
- System controls: Verify that system controls function and operate in the proper sequence.
- Low water temperature cutout: Verify that low water temperature cut-out controls are set properly (LT1 - JW3).

- Miscellaneous: Note any questionable aspects of the installation.

⚠ CAUTION! ⚠

CAUTION! Verify that ALL water valves are open and allow water flow prior to engaging the compressor. Freezing of the coax or water lines can permanently damage the heat pump.

⚠ CAUTION! ⚠

CAUTION! To avoid equipment damage, DO NOT leave system filled in a building without heat during the winter unless antifreeze is added to the water loop. Heat exchangers never fully drain by themselves and will freeze unless winterized with antifreeze.

Unit Start-up Procedure

1. Turn the thermostat fan position to "ON." Blower should start.
2. Turn Blower off.
3. Ensure all valves are adjusted to their full open position. Ensure line power to the heat pump is on.
4. Room temperature should be within the minimum-maximum ranges of listed in the unit IOM. During start-up checks, loop water temperature entering the heat pump should be between 30°F [-1°C] and 95°F [35°C].
5. It is recommended that water-to-air units be first started in the cooling mode, when possible. This will allow liquid refrigerant to flow through the filter-drier before entering the TXV, allowing the filter-drier to catch any debris that might be in the system before it reaches the TXV.
6. Two factors determine the operating limits of geothermal heat pumps, (a) return air temperature, and (b) entering water temperature. When either of the factors is at a minimum or maximum level, the other factor must be at normal levels to insure proper unit operation.
 - a. Place the unit in Manual Operation. When in manual mode activate Y1, Y2, and O to initiate the cooling mode. Also manually increase CFM until desired cooling CFM is achieved. Next adjust pump speed % until desired loop temperature difference (leaving water temperature minus entering water temperature) is achieved. (For modulating valve adjust valve %).

INSTALLER SETTINGS

THERMOSTAT CONFIG
 SYSTEM CONFIG
 ACCESSORY CONFIG
 INPUT DEALER INFO
 HUMIDITY CONFIG
 TEMPERATURE ALGORITHM
 DEMAND REDUCTION CNFG
SERVICE MODE
 RESTORY DEFAULTS

ATC32U01
 SELECT OPTION ▲ ▼
 ◀ PREVIOUS

Unit Start-Up Procedure

SERVICE MODE	
MANUAL OPERATION	
CONTROL DIAGNOSTICS	
DIPSWITCH CONFIG	
FAULT HISTORY	
CLEAR FAULT HISTORY	
SELECT OPTION ▲ ▼	SELECT ■
◀ PREVIOUS	

MANUAL OPERATING MODE			
Y1	COMM	OUTPUT	OFF
Y2	COMM	OUTPUT	OFF
W	COMM	OUTPUT	OFF
O	COMM	OUTPUT	OFF
G	COMM	OUTPUT	OFF
H	COMM	OUTPUT	OFF
DH	COMM	OUTPUT	OFF
ECM	AIRFLOW		0
PUMP	SPEED		0%
TEST	MODE		OFF
SELECT OPTION ▲ ▼	SELECT ■		
◀ PREVIOUS			

- b. Check for cool air delivery at the unit grille within a few minutes after the unit has begun to operate.

NOTE: Units have a five minute time delay in the control circuit that can be bypassed on the DXM2 control board by placing the unit in the “Test” mode as shown in the unit IOM. Check for normal air temperature drop of 15°F to 25°F (cooling mode).

- c. Verify that the compressor is on and that the water temperature rise (cooling mode) is within normal range.

Water Flow, gpm (l/m)	Rise, Cooling °F
For Closed Loop: Ground Source or Closed Loop Systems at 3 gpm per ton (3.9 l/m per kw)	9 - 12
For Open Loop: Ground Water Systems at 1.5 gpm per ton (2.0 l/m per kw)	20 - 26

- d. Check the elevation and cleanliness of the condensate lines. Dripping may be a sign of a blocked line. Check that the condensate trap is filled to provide a water seal.
- e. Turn thermostat to “OFF” position. A hissing noise indicates proper functioning of the reversing valve.
7. Allow five (5) minutes between tests for pressure to equalize before beginning heating test.

- a. Go into Manual Mode activate Y1, and Y2 for Heating. Also manually increase CFM until desired heating CFM is achieved. Next adjust pump speed % until desired loop temperature difference (entering water temperature minus leaving water temperature) is achieved. (For modulating valve adjust valve %).
- b. Check for warm air delivery at the unit grille within a few minutes after the unit has begun to operate.

NOTE: Units have a five minute time delay in the control circuit that can be bypassed on the DXM2 control board by placing the unit in the “Test” mode as shown in the unit IOM. Check for normal air temperature rise of 20°F to 30°F (heating mode).

Water Flow, gpm (l/m)	Drop, Heating °F
For Closed Loop: Ground Source or Closed Loop Systems at 3 gpm per ton (3.9 l/m per kw)	4 - 8
For Open Loop: Ground Water Systems at 1.5 gpm per ton (2.0 l/m per kw)	10 - 17

- c. Verify that the compressor is on and that the water temperature fall (heating mode) is within normal range.
- e. Check for vibration, noise, and water leaks.
8. If unit fails to operate properly, perform troubleshooting analysis (see troubleshooting section in the unit IOM). If the check described fails to reveal the problem and the unit still does not operate, contact a trained service technician to insure proper diagnosis and repair of the equipment.
9. When testing is complete, exit the Installer Menu and set thermostat to maintain desired comfort level for normal operation.
10. BE CERTAIN TO FILL OUT AND RETURN ALL WARRANTY REGISTRATION PAPERWORK.

Unit performance may be verified by calculating the unit heat of rejection and heat of extraction. Heat of Rejection (HR) can be calculated and compared to the performance data pages in this IOM. The formula for HR is as follows: $HR = TD \times GPM \times 500$ (or 485 for anti-freeze solutions), where TD is the temperature difference between the entering and leaving water, and GPM is the flow rate in U.S. GPM determined by comparing the unit heat exchanger pressure drop to Table 12.

Heat of Extraction (HE) can also be calculated and compared to the performance data pages in this IOM. The formula for HE is as follows: $HE = TD \times GPM \times 500$ (or 485 for anti-freeze solutions), where TD is the temperature difference between the entering and leaving water, and GPM is the flow rate in U.S. GPM determined by comparing the unit heat exchanger pressure drop to Table 12.

Unit Start-Up Procedure

If performance during any mode appears abnormal, refer to the DXM2 section or troubleshooting section of this manual.

NOTE: To obtain maximum performance, the air coil should be cleaned before start-up. A 10% solution of dishwasher detergent and water is recommended.

⚠ WARNING! ⚠

WARNING! When the disconnect switch is closed, high voltage is present in some areas of the electrical panel. Exercise caution when working with energized equipment.

Unit Operating Conditions

Table 12: Coax Water Pressure Drop

Model	GPM	Pressure Drop (psi)			
		30°F*	50°F	70°F	90°F
024	2.5	0.8	0.3	0.2	0.2
	3.0	1.2	0.6	0.5	0.5
	3.8	1.8	1.1	0.9	0.8
	4.5	2.7	1.6	1.2	1.2
	6.0	3.9	2.8	2.2	2.0
030	3.0	1.7	0.9	0.8	0.8
	3.8	2.3	1.2	1.1	1.1
	4.5	2.7	1.6	1.4	1.4
	6.0	3.8	2.4	2.2	2.1
	7.5	5.1	3.5	3.1	2.9
036	4.0	0.6	0.1	0.1	0.1
	6.0	1.8	1.0	0.7	0.7
	6.8	2.3	1.5	1.1	1.1
	8.0	3.2	2.2	1.8	1.7
	9.0	4.0	2.9	2.4	2.3
042	3.8	1.7	1.0	0.9	0.9
	5.3	2.7	1.8	1.6	1.5
	7.5	4.5	3.1	2.8	2.6
	7.9	4.8	3.4	3.1	2.9
	10.5	7.4	5.4	4.9	4.7
048	4.5	1.4	1.1	0.9	0.8
	6.0	2.0	1.7	1.4	1.3
	6.8	2.5	2.1	1.8	1.7
	9.0	4.0	3.4	3.0	2.7
	12.0	6.5	5.5	4.9	4.5
060	6.0	4.0	2.6	2.4	2.4
	7.5	5.4	3.8	3.3	3.3
	9.0	6.8	4.9	4.4	4.3
	12.0	10.6	7.9	7.0	6.7
	15.0	16.2	12.8	11.1	10.1

* Based on 15% methanol antifreeze solution

Table 13: Water Temperature Change Through Heat Exchanger

Water Flow, gpm (l/m)	Rise, Cooling °F	Drop, Heating °F
For Closed Loop: Ground Source or Closed Loop Systems at 3 gpm per ton (3.9 l/m per kw)	9 - 12	4 - 8
For Open Loop: Ground Water Systems at 1.5 gpm per ton (2.0 l/m per kw)	20 - 26	10 - 17

Table 14: Antifreeze Correction

Antifreeze Type	Antifreeze %	Cooling			Heating		WPD Corr. Fct. EWT 30°F
		EWT 90°F			EWT 30°F		
		Total Cap	Sens Cap	Power	Htg Cap	Power	
Water	0	1.000	1.000	1.000	1.000	1.000	1.000
	5	0.995	0.995	1.003	0.989	0.997	1.070
Propylene Glycol	15	0.986	0.986	1.009	0.968	0.990	1.210
	25	0.978	0.978	1.014	0.947	0.983	1.360
Methanol	5	0.997	0.997	1.002	0.989	0.997	1.070
	15	0.990	0.990	1.007	0.968	0.990	1.160
	25	0.982	0.982	1.012	0.949	0.984	1.220
Ethanol	5	0.998	0.998	1.002	0.981	0.994	1.140
	15	0.994	0.994	1.005	0.944	0.983	1.300
Ethylene Glycol	25	0.986	0.986	1.009	0.917	0.974	1.360
	5	0.998	0.998	1.002	0.993	0.998	1.040
	15	0.994	0.994	1.004	0.980	0.994	1.120
	25	0.988	0.988	1.008	0.966	0.990	1.200

Unit Operating Conditions

Table 15: Typical Unit Operating Pressures and Temperatures

024		Full Load Cooling - without HWG active						Full Load Heating - without HWG active					
Entering Water Temp °F	Water Flow GPM/ton	Suction Pressure PSIG	Discharge Pressure PSIG	Superheat	Subcooling	Water Temp Drop °F	Air Temp Drop °F DB	Suction Pressure PSIG	Discharge Pressure PSIG	Superheat	Subcooling	Water Temp Drop °F	Air Temp Rise °F DB
30*	1.5							67-77	305-325	6-11	6-11	8.0-10.0	19-25
	2.25							72-82	310-330	6-11	7-12	5.9-7.9	19-25
	3							77-87	314-334	6-11	7-12	3.8-5.8	19-25
50	1.5	127-137	244-264	9-14	13-18	20.6-22.6	19-25	98-108	346-366	9-14	8-13	11.1-13.1	26-32
	2.25	125-135	240-160	10-15	11-16	15.6-17.6	19-25	104-114	350-370	9-14	7-12	8.1-10.1	26-32
	3	124-134	237-257	11-16	8-13	11.4-13.4	19-25	111-121	355-375	9-14	6-11	5.2-7.2	27-33
70	1.5	132-142	322-342	8-13	14-19	20-22	18-24	129-139	384-404	11-16	10-15	14.4-16.4	32-38
	2.25	131-141	325-345	9-14	12-17	14.8-16.8	18-24	137-147	390-410	11-16	7-12	10.5-12.5	33-39
	3	130-140	329-349	9-14	10-15	9.6-11.6	18-24	145-155	397-417	11-16	6-11	6.5-8.5	34-40
90	1.5	140-150	410-430	6-11	15-20	19.9-21.9	17-23	162-172	421-441	14-19	8-13	17.5-19.5	39-45
	2.25	139-149	427-447	6-11	13-18	14.6-16.6	17-23	170-180	430-450	14-19	8-13	12.7-14.7	39-45
	3	138-148	444-464	7-12	11-16	9.4-11.4	17-23	178-188	440-460	14-19	8-13	9-11	41-47
110	1.5	144-154	490-510	5-10	16-21	19.8-21.8	16-22						
	2.25	143-153	500-520	5-10	14-19	14.45-16.45	16-22						
	3	143-153	513-533	5-10	13-18	9-11	16-22						

*Based on 15% Methanol antifreeze solution

030		Full Load Cooling - without HWG active						Full Load Heating - without HWG active					
Entering Water Temp °F	Water Flow GPM/ton	Suction Pressure PSIG	Discharge Pressure PSIG	Superheat	Subcooling	Water Temp Rise °F	Air Temp Drop °F DB	Suction Pressure PSIG	Discharge Pressure PSIG	Superheat	Subcooling	Water Temp Drop °F	Air Temp Rise °F DB
30*	1.5							65-75	311-331	9-14	9-14	8.0-10.0	19-24
	2.25							67-77	315-335	9-14	9-14	6.2-8.2	20-25
	3							72-82	319-339	9-14	9-14	4.3-6.3	21-26
50	1.5	122-132	240-260	10-15	11-16	19.5-21.5	18-23	95-105	353-373	11-16	10-15	10.5-12.5	26-31
	2.25	121-131	213-233	11-16	9-14	15.0-17.0	19-24	100-110	358-378	11-16	10-15	8.2-10.2	26-31
	3	121-131	186-206	11-16	7-12	10.3-12.3	19-24	105-115	362-382	12-17	10-15	5.8-7.8	27-32
70	1.5	122-132	316-336	9-14	12-17	18.8-20.8	17-22	124-134	390-410	13-18	10-15	13.5-15.5	33-38
	2.25	121-131	298-318	9-14	11-16	14.3-16.3	17-22	130-140	398-418	14-19	9-14	10.5-12.5	33-38
	3	121-131	280-300	9-14	9-14	9.8-11.8	17-22	137-147	405-425	15-20	9-14	7.5-9.5	34-39
90	1.5	133-143	438-458	8-13	14-19	17.8-19.8	15-20	156-166	430-450	16-21	8-13	16.5-18.5	37-42
	2.25	133-143	420-440	8-13	13-18	13.5-15.5	15-20	163-173	459-479	17-22	8-13	12.8-14.8	39-44
	3	132-142	401-421	8-13	11-16	9.2-11.2	15-20	170-180	448-468	18-23	8-13	9.0-11.0	40-45
110	1.5	137-147	507-527	6-11	16-21	17.2-19.2	15-20						
	2.25	136-146	490-510	7-12	14-19	13.0-15.0	15-20						
	3	135-145	473-493	7-12	13-18	8.8-10.8	15-20						

*Based on 15% Methanol antifreeze solution

036		Full Load Cooling - without HWG active						Full Load Heating - without HWG active					
Entering Water Temp °F	Water Flow GPM/ton	Suction Pressure PSIG	Discharge Pressure PSIG	Superheat	Subcooling	Water Temp Drop °F	Air Temp Drop °F DB	Suction Pressure PSIG	Discharge Pressure PSIG	Superheat	Subcooling	Water Temp Drop °F	Air Temp Rise °F DB
30*	1.5							60-70	315-335	6-11	11-16	10.0-12.0	18-23
	2.25							65-75	319-339	6-11	11-16	6.7-8.7	19-24
	3							70-80	325-345	6-11	11-16	3.4-5.4	20-25
50	1.5	123-133	232-252	11-16	12-17	19.9-21.9	19-24	88-98	353-373	9-14	14-19	13.2-15.2	24-29
	2.25	122-132	232-252	12-17	10-15	14.3-16.3	19-24	96-106	361-381	10-15	14-19	9.0-11.0	25-30
	3	121-131	232-252	13-18	7-12	9.6-11.6	19-24	105-115	370-390	10-15	14-19	4.8-6.8	26-31
70	1.5	128-138	310-330	10-15	11-16	19-21	18-23	116-126	390-410	11-16	15-20	17.0-19.0	29-34
	2.25	124-134	290-310	10-15	10-15	14.1-16.1	18-23	128-138	406-426	12-17	15-20	11.6-13.6	31-36
	3	119-129	270-290	11-16	8-13	9.2-11.2	18-23	139-149	419-439	14-19	15-20	6.1-8.1	32-37
90	1.5	135-145	420-440	7-12	11-16	18.1-20.1	17-22	148-158	436-456	14-19	15-20	20.9-22.9	35-40
	2.25	134-144	410-430	8-13	9-14	13.4-15.4	17-22	160-170	451-471	16-21	15-20	14.2-16.2	37-42
	3	132-142	390-410	8-13	8-13	8.7-10.7	17-22	173-183	466-486	17-22	15-20	7.4-9.4	39-44
110	1.5	139-149	490-510	6-11	10-15	17.8-19.8	16-21						
	2.25	138-148	480-500	6-11	9-14	13.2-15.2	16-21						
	3	137-147	470-490	6-11	8-13	8.6-10.6	16-21						

*Based on 15% Methanol antifreeze solution

Unit Operating Conditions

Table 15: Typical Unit Operating Pressures and Temperatures: Continued

042		Full Load Cooling - without HWG active						Full Load Heating - without HWG active					
Entering Water Temp °F	Water Flow GPM/ton	Suction Pressure PSIG	Discharge Pressure PSIG	Superheat	Subcooling	Water Temp Rise °F	Air Temp Drop °F DB	Suction Pressure PSIG	Discharge Pressure PSIG	Superheat	Subcooling	Water Temp Drop °F	Air Temp Rise °F DB
30*	1.5							64-74	314-334	6-11	9-14	8.0-10.0	20-25
	2.25							67-77	317-337	6-11	9-14	6.0-8.0	20-25
	3							71-81	321-341	7-12	9-14	4.0-6.0	21-26
50	1.5	121-131	230-250	10-15	10-15	20.5-22.5	22-27	95-105	351-371	8-13	9-14	10.7-12.7	26-31
	2.25	120-130	200-240	11-16	8-13	15.2-17.2	22-27	100-110	356-376	9-14	9-14	8.1-10.1	27-32
	3	120-130	164-184	11-16	6-11	9.8-11.8	22-27	104-114	361-381	10-15	9-14	5.4-7.4	27-32
70	1.5	127-137	305-325	8-13	10-15	19.8-21.8	20-25	124-134	386-406	11-16	8-13	13.8-15.8	32-37
	2.25	125-135	290-310	9-13	9-14	14.7-16.7	21-26	131-141	390-410	12-17	8-13	10.4-12.4	33-37
	3	125-135	263-283	10-15	7-12	9.5-11.5	21-26	138-148	400-420	13-18	7-12	7.0-9.0	34-39
90	1.5	133-143	426-446	7-12	11-16	19-21	19-24	157-167	423-443	13-18	5-10	16.8-18.8	38-43
	2.25	132-142	406-426	7-12	9-14	14-16	19-24	164-174	432-452	15-20	5-10	12.7-14.7	40-45
	3	132-142	390-410	7-12	8-13	9-11	19-24	172-182	441-461	16-21	5-10	8.5-10.5	41-46
110	1.5	137-147	494-514	5-10	11-16	18-20	18-23						
	2.25	136-146	477-497	6-11	10-15	14-16	18-23						
	3	136-146	460-480	6-11	8-13	9-11	18-23						

*Based on 15% Methanol antifreeze solution

048		Full Load Cooling - without HWG active						Full Load Heating - without HWG active					
Entering Water Temp °F	Water Flow GPM/ton	Suction Pressure PSIG	Discharge Pressure PSIG	Superheat	Subcooling	Water Temp Drop °F	Air Temp Drop °F DB	Suction Pressure PSIG	Discharge Pressure PSIG	Superheat	Subcooling	Water Temp Drop °F	Air Temp Rise °F DB
30*	1.5							61-71	290-310	9-14	5-10	7.7-9.7	18-23
	2.25							64-74	293-313	9-14	5-10	5.7-7.7	18-23
	3							68-78	296-316	10-15	5-10	3.7-5.7	18-23
50	1.5	124-134	250-270	11-16	13-18	20.1-22.1	19-24	88-98	319-339	11-16	6-11	10.3-12.3	24-29
	2.25	123-133	212-232	12-17	10-15	14.8-16.8	19-24	94-104	324-344	11-16	6-11	7.8-9.8	25-30
	3	121-131	173-193	13-18	7-12	9.5-11.5	19-24	100-110	330-350	12-17	6-11	5.3-7.3	25-30
70	1.5	129-139	334-354	9-14	16-21	19.6-21.6	18-23	117-127	349-369	13-18	5-10	13.4-15.4	29-34
	2.25	128-138	309-329	10-15	13-18	14.4-16.4	18-23	125-135	357-377	14-19	5-10	10.2-12.2	30-35
	3	127-137	284-304	10-15	10-15	9.3-11.3	18-23	133-143	365-385	15-20	4-11	6.9-8.9	31-36
90	1.5	135-145	470-490	7-12	20-25	18.9-20.9	16-21	150-160	384-404	15-20	3-8	16.6-18.6	35-40
	2.25	134-144	446-466	7-12	17-22	13.8-15.8	16-21	158-168	391-411	16-21	2-7	12.6-14.6	36-41
	3	132-142	422-442	8-13	15-20	8.8-10.8	16-21	166-176	399-419	17-22	2-7	8.5-10.5	37-42
110	1.5	138-148	548-568	6-11	22-27	18.6-20.6	15-20						
	2.25	138-148	526-546	6-11	19-24	13.6-15.6	15-20						
	3	137-147	505-525	6-11	17-22	8.6-10.6	15-20						

*Based on 15% Methanol antifreeze solution

060		Full Load Cooling - without HWG active						Full Load Heating - without HWG active					
Entering Water Temp °F	Water Flow GPM/ton	Suction Pressure PSIG	Discharge Pressure PSIG	Superheat	Subcooling	Water Temp Drop °F	Air Temp Drop °F DB	Suction Pressure PSIG	Discharge Pressure PSIG	Superheat	Subcooling	Water Temp Drop °F	Air Temp Rise °F DB
30*	1.5							64-74	309-329	7-12	10-15	8.4-10.4	19-24
	2.25							68-78	313-333	7-12	10-15	6.0-8.0	20-25
	3							71-81	317-337	8-13	10-15	3.6-5.6	20-25
50	1.5	120-130	225-245	9-14	13-18	21.8-23.8	20-25	94-104	343-363	9-14	12-18	11.3-13.3	25-30
	2.25	120-130	222-242	9-14	10-15	14.7-16.7	20-25	100-110	350-270	10-15	11-16	8.2-10.2	26-31
	3	118-128	220-240	9-14	9-14	8.7-10.7	20-25	105-115	356-376	10-15	10-15	5.0-8.0	26-31
70	1.5	124-134	300-320	8-13	14-19	19.9-21.9	19-24	122-132	377-397	11-16	9-14	14.2-16.2	31-36
	2.25	124-134	278-298	8-13	11-16	14.1-16.1	19-24	130-140	386-406	12-17	8-13	10.3-12.3	31-36
	3	123-133	256-276	8-13	9-14	8.3-10.3	19-24	137-147	394-414	13-18	7-12	6.5-8.5	33-38
90	1.5	130-140	420-440	7-12	16-21	19.0-21.0	17-22	155-165	412-432	14-19	6-11	17.2-19.2	36-41
	2.25	129-139	400-420	7-12	12-17	13.4-15.4	17-22	165-175	423-443	15-20	5-10	12.6-14.6	37-42
	3	129-139	390-410	7-12	9-14	7.9-9.9	17-22	175-185	423-443	16-21	4-9	7.9-9.9	39-44
110	1.5	133-143	495-515	6-11	16-21	18.5-20.5	16-21						
	2.25	132-142	475-495	6-11	13-18	13.1-15.1	16-21						
	3	132-142	454-474	6-11	9-14	7.6-9.6	16-21						

*Based on 15% Methanol antifreeze solution

Table 16a: Performance Data — GT-PB/50YF Model 024 - Full Load

Performance capacities shown in thousands of Btuh													Antifreeze use recommended in this range. Also Clip JW3 on DXM2 board.											
EWT °F	Cooling - EAT 80/67°F											Heating - EAT 70°F												
	GPM	WPD			CFM	TC	SC	kW	EER	HR	LWT	HWC	GPM	WPD			CFM	HC	kW	COP	HE	LAT	LWT	HWC
		PSI	FT	FT										PSI	FT	FT								
20	1.7	0.7	1.5	600	28.6	17.6	1.11	25.8	32.4	60.0	1.3	6.0	4.8	11.1	600	15.4	1.55	2.9	10.2	93.8	16.6	2.4		
	1.7	0.7	1.5	750	29.3	19.2	1.18	24.8	33.3	60.0	1.3	6.0	4.8	11.1	750	15.7	1.49	3.1	10.6	89.4	16.5	2.3		
30	2.2	0.6	1.4	600	28.6	17.6	1.11	25.8	32.4	60.0	1.3	3.0	1.2	2.7	600	17.1	1.59	3.2	11.7	96.4	22.2	2.5		
	2.2	0.6	1.4	750	29.3	19.2	1.18	24.8	33.3	60.0	1.3	3.0	1.2	2.7	750	17.4	1.53	3.3	12.2	91.5	21.9	2.4		
	2.2	0.6	1.4	600	28.6	17.6	1.11	25.8	32.4	60.0	1.3	4.5	2.4	5.6	600	17.9	1.62	3.2	12.4	97.7	24.5	2.6		
	2.2	0.6	1.4	750	29.3	19.2	1.18	24.8	33.3	60.0	1.3	4.5	2.4	5.6	750	18.2	1.56	3.4	12.9	92.5	24.3	2.5		
	2.2	0.6	1.4	600	28.6	17.6	1.11	25.8	32.4	60.0	1.3	6.0	3.9	9.1	600	18.4	1.63	3.3	12.8	98.4	25.7	2.6		
	2.2	0.6	1.4	750	29.3	19.2	1.18	24.8	33.3	60.0	1.3	6.0	3.9	9.1	750	18.7	1.57	3.5	13.3	93.1	25.6	2.5		
40	3.0	0.8	1.9	600	28.4	17.5	1.13	25.2	32.2	61.5	1.4	3.0	0.8	1.9	600	20.0	1.67	3.5	14.3	100.8	30.5	2.7		
	3.0	0.8	1.9	750	29.1	19.1	1.20	24.2	33.2	62.1	1.4	3.0	0.8	1.9	750	20.3	1.61	3.7	14.8	95.1	30.1	2.6		
	3.3	1.0	2.4	600	28.6	17.6	1.11	25.8	32.4	60.0	1.3	4.5	1.9	4.5	600	21.0	1.70	3.6	15.2	102.5	33.2	2.8		
	3.3	1.0	2.4	750	29.3	19.2	1.18	24.8	33.3	60.0	1.3	4.5	1.9	4.5	750	21.4	1.63	3.8	15.8	96.4	33.0	2.7		
	3.3	1.0	2.4	600	28.6	17.6	1.11	25.8	32.4	60.0	1.3	6.0	3.3	7.6	600	21.6	1.72	3.7	15.8	103.3	34.7	2.9		
	3.3	1.0	2.4	750	29.3	19.2	1.18	24.8	33.3	60.0	1.3	6.0	3.3	7.6	750	22.0	1.65	3.9	16.4	97.1	34.5	2.8		
50	3.0	0.6	1.4	600	27.4	17.2	1.24	22.1	31.6	71.1	1.7	3.0	0.6	1.4	600	23.0	1.75	3.9	17.0	105.5	38.7	3.0		
	3.0	0.6	1.4	750	28.1	18.7	1.32	21.3	32.6	71.7	1.8	3.0	0.6	1.4	750	23.4	1.68	4.1	17.6	98.9	38.2	2.9		
	4.5	1.6	3.7	600	28.1	17.5	1.15	24.3	32.1	64.2	1.5	4.5	1.6	3.7	600	24.2	1.78	4.0	18.2	107.4	41.9	3.1		
	4.5	1.6	3.7	750	28.8	19.0	1.23	23.4	33.0	64.7	1.5	4.5	1.6	3.7	750	24.6	1.71	4.2	18.8	100.4	41.6	3.0		
	6.0	2.8	6.4	600	28.5	17.6	1.12	25.5	32.3	60.8	1.3	6.0	2.8	6.5	600	24.9	1.80	4.1	18.8	108.4	43.7	3.2		
	6.0	2.8	6.4	750	29.2	19.1	1.19	24.5	33.2	61.1	1.3	6.0	2.8	6.5	750	25.3	1.73	4.3	19.4	101.3	43.5	3.1		
60	3.0	0.5	1.2	600	26.4	16.7	1.36	19.4	31.0	80.7	2.3	3.0	0.5	1.2	600	25.9	1.82	4.2	19.7	110.0	46.9	3.3		
	3.0	0.5	1.2	750	27.0	18.2	1.45	18.6	32.0	81.3	2.4	3.0	0.5	1.2	750	26.4	1.75	4.4	20.4	102.6	46.4	3.2		
	4.5	1.4	3.2	600	27.1	17.0	1.27	21.4	31.4	74.0	1.9	4.5	1.4	3.2	600	27.3	1.86	4.3	20.9	112.1	50.7	3.5		
	4.5	1.4	3.2	750	27.8	18.5	1.35	20.6	32.4	74.4	2.0	4.5	1.4	3.2	750	27.7	1.79	4.5	21.6	104.2	50.4	3.4		
	6.0	2.5	5.7	600	27.5	17.2	1.23	22.3	31.7	70.6	1.7	6.0	2.5	5.7	600	28.0	1.88	4.4	21.6	113.2	52.8	3.5		
	6.0	2.5	5.7	750	28.2	18.7	1.31	21.5	32.6	70.9	1.8	6.0	2.5	5.7	750	28.5	1.81	4.6	22.3	105.1	52.6	3.4		
70	3.0	0.5	1.1	600	25.2	16.2	1.52	16.6	30.4	90.3	3.0	3.0	0.5	1.1	600	28.6	1.90	4.4	22.2	114.2	55.2	3.6		
	3.0	0.5	1.1	750	25.8	17.7	1.62	15.9	31.4	90.9	3.1	3.0	0.5	1.1	750	29.1	1.83	4.7	22.9	106.0	54.7	3.5		
	4.5	1.2	2.9	600	26.0	16.6	1.41	18.5	30.8	83.7	2.5	4.5	1.2	2.9	600	29.9	1.96	4.5	23.3	116.2	59.7	3.8		
	4.5	1.2	2.9	750	26.7	18.0	1.50	17.8	31.8	84.1	2.6	4.5	1.2	2.9	750	30.5	1.88	4.7	24.1	107.6	59.3	3.7		
	6.0	2.2	5.2	600	26.4	16.7	1.35	19.5	31.0	80.3	2.3	6.0	2.2	5.2	600	30.6	1.98	4.5	23.8	117.2	62.1	3.9		
	6.0	2.2	5.2	750	27.1	18.2	1.44	18.8	32.0	80.7	2.4	6.0	2.2	5.2	750	31.1	1.90	4.8	24.6	108.4	61.8	3.8		
80	3.0	0.5	1.1	600	23.9	15.8	1.72	13.9	29.8	99.8	3.9	3.0	0.5	1.1	600	30.9	1.99	4.6	24.2	117.8	63.9	4.0		
	3.0	0.5	1.1	750	24.5	17.1	1.83	13.4	30.7	100.5	4.0	3.0	0.5	1.1	750	31.5	1.91	4.8	25.0	108.9	63.4	3.9		
	4.5	1.2	2.7	600	24.8	16.1	1.58	15.7	30.2	93.4	3.3	4.5	1.2	2.7	600	32.0	2.05	4.6	25.0	119.3	68.9	4.3		
	4.5	1.2	2.7	750	25.4	17.5	1.68	15.1	31.2	93.8	3.4	4.5	1.2	2.7	750	32.5	1.97	4.8	25.8	110.1	68.5	4.2		
	6.0	2.1	4.9	600	25.3	16.3	1.51	16.7	30.4	90.1	3.0	6.0	2.1	4.9	600	32.2	2.06	4.6	25.2	119.7	70.0	4.3		
	6.0	2.1	4.9	750	25.9	17.7	1.61	16.1	31.4	90.5	3.1	6.0	2.1	4.9	750	32.8	1.98	4.8	26.0	110.4	70.0	4.2		
90	3.0	0.5	1.1	600	22.4	15.2	1.99	11.2	29.1	109.4	4.8	2.6	0.3	0.8	600	32.2	2.06	4.6	25.2	119.7	70.0	4.3		
	3.0	0.5	1.1	750	24.0	17.0	1.92	12.5	30.6	110.1	4.3	2.6	0.3	0.8	750	32.8	1.98	4.8	26.0	110.4	70.0	4.2		
	4.5	1.2	2.7	600	23.4	15.6	1.80	13.0	29.6	103.1	4.2	2.6	0.3	0.8	600	32.2	2.06	4.6	25.2	119.7	70.0	4.3		
	4.5	1.2	2.7	750	24.0	17.0	1.92	12.5	30.6	103.6	4.3	2.6	0.3	0.8	750	32.8	1.98	4.8	26.0	110.4	70.0	4.2		
	6.0	2.0	4.7	600	23.9	15.8	1.72	13.9	29.8	99.9	3.8	2.6	0.3	0.8	600	32.2	2.06	4.6	25.2	119.7	70.0	4.3		
	6.0	2.0	4.7	750	24.5	17.2	1.83	13.4	30.8	100.3	3.9	2.6	0.3	0.8	750	32.8	1.98	4.8	26.0	110.4	70.0	4.2		
100	3.0	0.5	1.1	600	20.5	14.7	2.34	8.8	28.5	119.0	5.9	1.7	0.2	0.5	600	32.2	2.06	4.6	25.2	119.7	70.0	4.3		
	3.0	0.5	1.1	750	21.0	16.0	2.49	8.4	29.5	119.7	6.1	1.7	0.2	0.5	750	32.8	1.98	4.8	26.0	110.4	70.0	4.2		
	4.5	1.2	2.7	600	21.8	15.1	2.09	10.4	28.9	112.9	5.1	1.7	0.2	0.5	600	32.2	2.06	4.6	25.2	119.7	70.0	4.3		
	4.5	1.2	2.7	750	22.3	16.4	2.23	10.0	29.9	113.3	5.3	1.7	0.2	0.5	750	32.8	1.98	4.8	26.0	110.4	70.0	4.2		
	6.0	2.0	4.6	600	22.4	15.2	1.99	11.2	29.2	109.7	4.8	1.7	0.2	0.5	600	32.2	2.06	4.6	25.2	119.7	70.0	4.3		
	6.0	2.0	4.6	750	22.9	16.6	2.12	10.8	30.1	110.0	5.0	1.7	0.2	0.5	750	32.8	1.98	4.8	26.0	110.4	70.0	4.2		
110	3.0	0.5	1.0	600	18.3	14.0	2.79	6.6	27.9	128.6	7.2	1.3	0.1	0.2	600	32.2	2.06	4.6	25.2	119.7	70.0	4.3		
	3.0	0.5	1.0	750	18.8	15.2	2.97	6.3	28.9	129.3	7.4	1.3	0.1	0.2	750	32.8	1.98	4.8	26.0	110.4	70.0	4.2		
	4.5	1.1	2.5	600	19.8	14.4	2.49	8.0	28.3	122.6	6.3	1.3	0.1	0.2	600	32.2	2.06	4.6	25.2	119.7	70.0	4.3		
	4.5	1.1	2.5	750	20.3	15.7	2.65	7.7	29.3	123.0	6.5	1.3	0.1	0.2	750	32.8	1.98	4.8	26.0	110.4	70.0	4.2		
	6.0	1.9	4.4	600	20.5	14.7	2.35	8.7	28.5	119.5	5.9	1.3	0.1	0.2	600	32.2	2.06	4.6	25.2	119.7	70.0	4.3		
	6.0	1.9	4.4	750	21.0	16.0	2.50	8.4	29.5	119.8	6.1	1.3	0.1	0.2	750	32.8	1.98	4.8	26.0	110.4	70.0	4.2		
120	3.0	0.3	0.8	600	15.8	13.0	3.36	4.7	27.2	138.2	8.5	1.0	0.1	0.2	600	32.2	2.06	4.6	25.2	119.7	70.0	4.3		
	3.0	0.3	0.8	750	16.2	14.1	3.58	4.5	28.4	138.9	8.8	1.0	0.1	0.2	750	32.8	1.98	4.8	26.0	110.4	70.0	4.2		
	4.5	1.0	2.3	600	17.5	13.7	2.98	5.9	27.6	132.3	7.7	1.0	0.1	0.2	600	32.2	2.06	4.6	25.2	119.7	70.0	4.3		
	4.5	1.0	2.3	750	17.9	14.9	3.17	5.6	28															

Table 16b: Performance Data — GT-PB/50YF Model 030 - Full Load

Performance capacities shown in thousands of Btu/h												Antifreeze use recommended in this range. Also Clip JW3 on DXM2 board.										
EWT °F	Cooling - EAT 80/67°F											Heating - EAT 70°F										
	GPM	WPD		CFM	TC	SC	kW	EER	HR	LWT	HWC	GPM	WPD		CFM	HC	kW	COP	HE	LAT	LWT	HWC
		PSI	FT										PSI	FT								
20	2.0	1.5	3.4	720	33.8	19.8	1.4	23.9	38.7	60.0	1.6	7.5	5.7	13.3	720	21.4	2.0	3.1	14.5	98	16.1	2.8
	2.0	1.5	3.4	900	34.7	21.5	1.5	23.0	39.8	60.0	1.7	7.5	5.7	13.3	900	21.8	1.9	3.3	15.2	92	16.0	2.7
30	2.7	1.4	3.2	720	33.8	19.8	1.4	23.9	38.7	60.0	1.6	3.8	2.3	5.2	720	23.1	2.1	3.3	16.1	100	21.4	2.9
	2.7	1.4	3.2	900	34.7	21.5	1.5	23.0	39.8	60.0	1.7	3.8	2.3	5.2	900	23.5	2.0	3.5	16.7	94	21.1	2.8
	2.7	1.4	3.2	720	33.8	19.8	1.4	23.9	38.7	60.0	1.6	5.6	3.5	8.1	720	24.0	2.1	3.4	16.9	101	24.0	3.0
	2.7	1.4	3.2	900	34.7	21.5	1.5	23.0	39.8	60.0	1.7	5.6	3.5	8.1	900	24.5	2.0	3.6	17.6	95	23.7	2.9
	2.7	1.4	3.2	720	33.8	19.8	1.4	23.9	38.7	60.0	1.6	7.5	5.1	11.8	720	24.6	2.1	3.4	17.3	102	25.4	3.0
	2.7	1.4	3.2	900	34.7	21.5	1.5	23.0	39.8	60.0	1.7	7.5	5.1	11.8	900	25.0	2.0	3.6	18.0	96	25.2	2.9
40	3.8	1.7	4.0	720	33.7	19.7	1.4	23.5	38.6	60.6	1.6	3.8	1.7	4.0	720	26.1	2.2	3.5	18.7	104	30.0	3.1
	3.8	1.7	4.0	900	34.5	21.5	1.5	22.6	39.7	61.2	1.7	3.8	1.7	4.0	900	26.6	2.1	3.7	19.5	97	29.6	3.0
	4.0	1.8	4.2	720	33.8	19.8	1.4	23.9	38.7	60.0	1.6	5.6	2.9	6.6	720	27.2	2.2	3.6	19.7	105	33.0	3.2
	4.0	1.8	4.2	900	34.7	21.5	1.5	23.0	39.8	60.0	1.7	5.6	2.9	6.6	900	27.7	2.1	3.8	20.5	98	32.7	3.1
	4.0	1.8	4.2	720	33.8	19.8	1.4	23.9	38.7	60.0	1.6	7.5	4.3	10.0	720	27.8	2.2	3.7	20.3	106	34.6	3.3
	4.0	1.8	4.2	900	34.7	21.5	1.5	23.0	39.8	60.0	1.7	7.5	4.3	10.0	900	28.3	2.1	3.9	21.0	99	34.4	3.2
50	3.8	1.2	2.8	720	32.7	19.3	1.6	20.8	38.0	70.3	2.2	3.8	1.2	2.8	720	29.2	2.3	3.8	21.5	108	38.5	3.4
	3.8	1.2	2.8	900	33.5	21.0	1.7	20.0	39.2	70.9	2.2	3.8	1.2	2.8	900	29.7	2.2	4.0	22.3	101	38.1	3.3
	5.6	2.2	5.1	720	33.4	19.6	1.5	22.7	38.4	63.7	1.8	5.6	2.2	5.1	720	30.5	2.3	3.9	22.6	109	42.0	3.6
	5.6	2.2	5.1	900	34.2	21.4	1.6	21.8	39.6	64.1	1.8	5.6	2.2	5.1	900	31.0	2.2	4.1	23.5	102	41.7	3.5
	7.5	3.5	8.1	720	33.8	19.8	1.4	23.7	38.6	60.3	1.6	7.5	3.5	8.1	720	31.2	2.3	3.9	23.3	110	43.8	3.6
	7.5	3.5	8.1	900	34.6	21.5	1.5	22.8	39.8	60.6	1.7	7.5	3.5	8.1	900	31.7	2.2	4.2	24.1	103	43.6	3.5
60	3.8	1.2	2.7	720	31.4	18.9	1.7	18.2	37.3	79.9	2.8	3.8	1.2	2.7	720	32.3	2.4	4.0	24.3	112	47.1	3.8
	3.8	1.2	2.7	900	32.1	20.5	1.8	17.5	38.4	80.5	2.9	3.8	1.2	2.7	900	32.9	2.3	4.2	25.1	104	46.6	3.7
	5.6	2.0	4.6	720	32.3	19.2	1.6	20.0	37.8	73.4	2.3	5.6	2.0	4.6	720	33.8	2.4	4.1	25.6	113	50.9	4.0
	5.6	2.0	4.6	900	33.1	20.9	1.7	19.2	38.9	73.8	2.4	5.6	2.0	4.6	900	34.4	2.3	4.4	26.5	105	50.6	3.9
	7.5	3.3	7.6	720	32.7	19.4	1.6	20.9	38.0	70.1	2.1	7.5	3.3	7.6	720	34.6	2.4	4.2	26.3	114	53.0	4.1
	7.5	3.3	7.6	900	33.5	21.1	1.7	20.1	39.2	70.5	2.2	7.5	3.3	7.6	900	35.2	2.3	4.4	27.2	106	52.8	4.0
70	3.8	1.1	2.5	720	29.9	18.3	1.9	15.7	36.4	89.4	3.5	3.8	1.1	2.5	720	35.4	2.5	4.2	27.0	116	55.6	4.2
	3.8	1.1	2.5	900	30.7	19.9	2.0	15.1	37.6	90.0	3.7	3.8	1.1	2.5	900	36.0	2.4	4.5	28.0	107	55.1	4.1
	5.6	1.9	4.5	720	30.9	18.7	1.8	17.4	37.0	83.2	3.0	5.6	1.9	4.5	720	37.0	2.5	4.3	28.5	118	59.9	4.5
	5.6	1.9	4.5	900	31.7	20.3	1.9	16.7	38.1	83.6	3.1	5.6	1.9	4.5	900	37.7	2.4	4.6	29.4	109	59.5	4.4
	7.5	3.1	7.2	720	31.4	18.9	1.7	18.2	37.3	79.9	2.8	7.5	3.1	7.2	720	37.9	2.5	4.4	29.2	119	62.2	4.6
	7.5	3.1	7.2	900	32.2	20.5	1.8	17.6	38.4	80.2	2.9	7.5	3.1	7.2	900	38.6	2.4	4.6	30.2	110	61.9	4.5
80	3.8	1.1	2.5	720	28.3	17.7	2.1	13.5	35.5	98.9	4.4	3.8	1.1	2.5	720	38.5	2.6	4.4	29.8	120	64.1	4.7
	3.8	1.1	2.5	900	29.0	19.2	2.2	13.0	36.7	99.6	4.6	3.8	1.1	2.5	900	39.2	2.5	4.7	30.8	110	63.6	4.6
	5.6	1.9	4.4	720	29.4	18.1	2.0	14.9	36.1	92.8	3.8	5.6	1.9	4.4	720	40.3	2.6	4.5	31.3	122	68.9	5.1
	5.6	1.9	4.4	900	30.1	19.7	2.1	14.4	37.3	93.2	3.9	5.6	1.9	4.4	900	40.9	2.5	4.8	32.4	112	68.5	4.9
	7.5	3.0	7.0	720	29.9	18.3	1.9	15.7	36.4	89.7	3.5	6.6	2.4	5.5	720	40.8	2.6	4.5	31.8	122	70.0	5.3
	7.5	3.0	7.0	900	30.7	19.9	2.0	15.1	37.6	90.0	3.7	6.6	2.4	5.5	900	41.5	2.5	4.8	32.8	113	70.0	5.1
90	3.8	1.1	2.5	720	26.7	17.0	2.3	11.4	34.6	108.5	5.4	3.3	0.9	2.0	720	40.8	2.6	4.5	31.8	122	70.0	5.3
	3.8	1.1	2.5	900	28.4	19.0	2.3	12.2	36.4	109.1	4.9	3.3	0.9	2.0	900	41.5	2.5	4.8	32.8	113	70.0	5.1
	5.6	1.9	4.3	720	27.8	17.4	2.2	12.7	35.2	102.5	4.7	3.3	0.9	2.0	720	40.8	2.6	4.5	31.8	122	70.0	5.3
	5.6	1.9	4.3	900	28.4	19.0	2.3	12.2	36.4	102.9	4.9	3.3	0.9	2.0	900	41.5	2.5	4.8	32.8	113	70.0	5.1
	7.5	2.9	6.8	720	28.3	17.6	2.1	13.4	35.5	99.5	4.4	3.3	0.9	2.0	720	40.8	2.6	4.5	31.8	122	70.0	5.3
	7.5	2.9	6.8	900	29.0	19.2	2.2	12.9	36.7	99.8	4.6	3.3	0.9	2.0	900	41.5	2.5	4.8	32.8	113	70.0	5.1
100	3.8	1.0	2.3	720	25.0	16.2	2.6	9.6	33.8	118.0	6.5	2.2	0.5	1.2	720	40.8	2.6	4.5	31.8	122	70.0	5.3
	3.8	1.0	2.3	900	25.6	17.7	2.8	9.2	35.0	118.7	6.7	2.2	0.5	1.2	900	41.5	2.5	4.8	32.8	113	70.0	5.1
	5.6	1.8	4.1	720	26.0	16.7	2.4	10.7	34.3	112.2	5.8	2.2	0.5	1.2	720	40.8	2.6	4.5	31.8	122	70.0	5.3
	5.6	1.8	4.1	900	26.7	18.2	2.6	10.3	35.5	112.6	6.0	2.2	0.5	1.2	900	41.5	2.5	4.8	32.8	113	70.0	5.1
	7.5	2.8	6.5	720	26.6	16.9	2.3	11.3	34.6	109.2	5.4	2.2	0.5	1.2	720	40.8	2.6	4.5	31.8	122	70.0	5.3
	7.5	2.8	6.5	900	27.2	18.4	2.5	10.9	35.8	109.5	5.6	2.2	0.5	1.2	900	41.5	2.5	4.8	32.8	113	70.0	5.1
110	3.8	0.9	2.2	720	23.2	15.5	2.9	8.0	33.2	127.7	7.7	1.6	0.3	0.8	720	40.8	2.6	4.5	31.8	122	70.0	5.3
	3.8	0.9	2.2	900	23.8	16.9	3.1	7.7	34.4	128.3	8.0	1.6	0.3	0.8	900	41.5	2.5	4.8	32.8	113	70.0	5.1
	5.6	1.7	3.9	720	24.3	16.0	2.7	8.9	33.6	121.9	7.0	1.6	0.3	0.8	720	40.8	2.6	4.5	31.8	122	70.0	5.3
	5.6	1.7	3.9	900	24.9	17.4	2.9	8.6	34.8	122.4	7.2	1.6	0.3	0.8	900	41.5	2.5	4.8	32.8	113	70.0	5.1
	7.5	2.7	6.2	720	24.8	16.2	2.6	9.5	33.8	119.0	6.6	1.6	0.3	0.8	720	40.8	2.6	4.5	31.8	122	70.0	5.3
	7.5	2.7	6.2	900	25.5	17.6	2.8	9.1	35.0	119.3	6.8	1.6	0.3	0.8	900	41.5	2.5	4.8	32.8	113	70.0	5.1
120												1.3	0.1	0.2	720	40.8	2.6	4.5	31.8	122	70.0	5.3
												1.3	0.1	0.2	900	41.5	2.5	4.8	32.8	113	70.0	5.1
	5.6	1.6	3.7	720	22.6	15.2	3.0	7.4	33.0	131.7	8.3	1.3	0.1	0.2	720	40.8	2.6	4.5	31.8	122	70.0	5.3
	5.6	1.6	3.7	900	23.1	16.5	3.2	7.1	34.2	132.2	8.5	1.3	0.1	0.2	900	41.5	2.5	4.8	32.8	113	70.0	5.1
	7.5	2.6	6.0	720	23.1	15.4	2.9	7.9	33.1	128.8	7.8	1.3	0.1	0.2	720	40.8	2.6	4.5	31.8	122	70.0	5.3
	7.5	2.6	6.0	900	23.7	16.8	3.1	7.6	34.4	129.2	8.1	1.3	0.1	0.2	900	41.5	2.5	4.8	32.8			

Table 16c: Performance Data — GT-PB/50YF Model 036 - Full Load

Performance capacities shown in thousands of Btuh											Antifreeze use recommended in this range. Also Clip JW3 on DXM2 board.											
EWT °F	Cooling - EAT 80/67°F											Heating - EAT 70°F										
	GPM	WPD		CFM	TC	SC	kW	EER	HR	LWT	HWC	GPM	WPD		CFM	HC	kW	COP	HE	LAT	LWT	HWC
		PSI	FT										PSI	FT								
20	2.3	0.2	0.4	920	39.8	25.3	1.59	25.1	45.2	60.0	1.7	9.0	4.9	11.4	920	24.7	2.40	3.0	16.5	94.8	16.3	3.4
	2.3	0.2	0.4	1150	40.8	27.6	1.69	24.2	46.6	60.0	1.8	9.0	4.9	11.4	1150	25.1	2.31	3.2	17.2	90.2	16.2	3.3
30	3.1	0.1	0.3	920	39.8	25.3	1.59	25.1	45.2	60.0	1.7	4.5	0.8	1.9	920	26.8	2.45	3.2	18.4	97.0	21.8	3.5
	3.1	0.1	0.3	1150	40.8	27.6	1.69	24.2	46.6	60.0	1.8	4.5	0.8	1.9	1150	27.3	2.36	3.4	19.2	92.0	21.5	3.4
	3.1	0.1	0.3	920	39.8	25.3	1.59	25.1	45.2	60.0	1.7	6.8	2.3	5.4	920	27.9	2.48	3.3	19.5	98.1	24.2	3.6
	3.1	0.1	0.3	1150	40.8	27.6	1.69	24.2	46.6	60.0	1.8	6.8	2.3	5.4	1150	28.4	2.38	3.5	20.3	92.9	24.0	3.5
	3.1	0.1	0.3	920	39.8	25.3	1.59	25.1	45.2	60.0	1.7	9.0	4.0	9.3	920	28.5	2.50	3.4	20.0	98.7	25.6	3.6
	3.1	0.1	0.3	1150	40.8	27.6	1.69	24.2	46.6	60.0	1.8	9.0	4.0	9.3	1150	29.0	2.40	3.5	20.8	93.4	25.4	3.5
40	4.5	0.5	1.1	920	39.8	25.3	1.60	24.9	45.2	60.1	1.7	4.5	0.5	1.1	920	30.6	2.54	3.5	22.0	100.8	30.2	3.8
	4.5	0.5	1.1	1150	40.8	27.6	1.70	24.0	46.6	60.7	1.8	4.5	0.5	1.1	1150	31.1	2.44	3.7	22.8	95.1	29.9	3.7
	4.7	0.6	1.3	920	39.8	25.3	1.59	25.1	45.2	60.0	1.7	6.8	1.8	4.2	920	32.0	2.57	3.7	23.3	102.2	33.1	3.9
	4.7	0.6	1.3	1150	40.8	27.6	1.69	24.2	46.6	60.0	1.8	6.8	1.8	4.2	1150	32.6	2.47	3.9	24.2	96.2	32.8	3.8
	4.7	0.6	1.3	920	39.8	25.3	1.59	25.1	45.2	60.0	1.7	9.0	3.4	7.8	920	32.8	2.59	3.7	24.0	103.0	34.7	4.0
	4.7	0.6	1.3	1150	40.8	27.6	1.69	24.2	46.6	60.0	1.8	9.0	3.4	7.8	1150	33.4	2.49	3.9	24.9	96.9	34.5	3.9
50	4.5	0.2	0.5	920	39.0	25.2	1.73	22.6	44.9	70.0	2.3	4.5	0.2	0.5	920	34.6	2.63	3.9	25.7	104.9	38.6	4.2
	4.5	0.2	0.5	1150	40.0	27.4	1.84	21.7	46.2	70.6	2.4	4.5	0.2	0.5	1150	35.2	2.53	4.1	26.6	98.4	38.2	4.1
	6.8	1.5	3.3	920	39.6	25.3	1.63	24.2	45.2	63.4	1.9	6.8	1.5	3.4	920	36.3	2.66	4.0	27.2	106.6	41.9	4.3
	6.8	1.5	3.3	1150	40.6	27.5	1.74	23.3	46.5	63.8	2.0	6.8	1.5	3.4	1150	37.0	2.56	4.2	28.2	99.8	41.6	4.2
	9.0	2.9	6.7	920	39.8	25.3	1.60	24.9	45.3	60.1	1.7	9.0	2.9	6.7	920	37.3	2.69	4.1	28.1	107.5	43.8	4.4
	9.0	2.9	6.7	1150	40.8	27.6	1.70	24.0	46.6	60.4	1.8	9.0	2.9	6.7	1150	37.9	2.59	4.3	29.1	100.5	43.5	4.3
60	4.5	0.1	0.3	920	37.8	24.7	1.90	19.9	44.3	79.7	3.1	4.5	0.1	0.3	920	38.7	2.72	4.2	29.4	108.9	46.9	4.6
	4.5	0.1	0.3	1150	38.8	26.9	2.02	19.2	45.7	80.3	3.2	4.5	0.1	0.3	1150	39.3	2.62	4.4	30.4	101.7	46.5	4.5
	6.8	1.2	2.8	920	38.7	25.0	1.78	21.7	44.8	73.3	2.5	6.8	1.2	2.9	920	40.5	2.79	4.3	31.0	110.8	50.8	4.9
	6.8	1.2	2.8	1150	39.6	27.2	1.90	20.9	46.1	73.7	2.6	6.8	1.2	2.9	1150	41.2	2.68	4.5	32.1	103.2	50.5	4.8
	9.0	2.6	5.9	920	39.0	25.2	1.73	22.6	44.9	70.0	2.3	9.0	2.6	5.9	920	41.5	2.82	4.3	31.9	111.8	52.9	5.0
	9.0	2.6	5.9	1150	40.0	27.4	1.84	21.7	46.3	70.3	2.4	9.0	2.6	5.9	1150	42.2	2.71	4.6	33.0	104.0	52.7	4.9
70	4.5	0.1	0.3	920	36.4	24.1	2.10	17.3	43.6	89.4	4.1	4.5	0.1	0.3	920	42.5	2.86	4.4	32.7	112.8	55.5	5.2
	4.5	0.1	0.3	1150	37.3	26.3	2.24	16.6	44.9	90.0	4.2	4.5	0.1	0.3	1150	43.2	2.75	4.6	33.8	104.8	55.0	5.0
	6.8	1.1	2.6	920	37.4	24.6	1.96	19.1	44.1	83.1	3.4	6.8	1.1	2.6	920	44.3	2.94	4.4	34.3	114.6	59.8	5.6
	6.8	1.1	2.6	1150	38.3	26.7	2.09	18.3	45.4	83.5	3.5	6.8	1.1	2.6	1150	45.1	2.83	4.7	35.4	106.3	59.5	5.4
	9.0	2.4	5.5	920	37.9	24.7	1.90	20.0	44.3	79.9	3.0	9.0	2.4	5.5	920	45.2	2.98	4.4	35.0	115.5	62.2	5.7
	9.0	2.4	5.5	1150	38.8	26.9	2.02	19.2	45.7	80.2	3.1	9.0	2.4	5.5	1150	46.0	2.87	4.7	36.2	107.0	62.0	5.5
80	4.5	0.1	0.3	920	34.7	23.4	2.36	14.7	42.7	99.0	5.2	4.5	0.1	0.3	920	45.8	3.03	4.4	35.5	116.1	64.2	5.9
	4.5	0.1	0.3	1150	35.5	25.5	2.51	14.1	44.1	99.6	5.4	4.5	0.1	0.3	1150	46.6	2.91	4.7	36.7	107.5	63.7	5.7
	6.8	1.1	2.5	920	35.8	23.9	2.19	16.4	43.3	92.8	4.5	6.8	1.1	2.5	920	47.4	3.14	4.4	36.7	117.7	69.2	6.3
	6.8	1.1	2.5	1150	36.7	26.0	2.33	15.7	44.6	93.2	4.6	6.8	1.1	2.5	1150	48.2	3.02	4.7	37.9	108.8	68.8	6.1
	9.0	2.3	5.3	920	36.4	24.1	2.10	17.3	43.5	89.7	4.1	7.6	1.5	3.5	920	47.7	3.17	4.4	36.9	118.0	70.0	6.4
	9.0	2.3	5.3	1150	37.3	26.3	2.24	16.6	44.9	90.0	4.2	7.6	1.5	3.5	1150	48.5	3.05	4.7	38.1	109.1	70.0	6.2
90	4.5	0.2	0.4	920	32.7	22.6	2.65	12.4	41.8	108.6	6.6	3.8	0.1	0.2	920	47.7	3.17	4.4	36.9	118.0	70.0	6.4
	4.5	0.2	0.4	1150	34.8	25.2	2.61	13.3	43.7	109.2	5.9	3.8	0.1	0.2	1150	48.5	3.05	4.7	38.1	109.1	70.0	6.2
	6.8	1.1	2.5	920	34.0	23.2	2.45	13.9	42.4	102.6	5.7	3.8	0.1	0.2	920	47.7	3.17	4.4	36.9	118.0	70.0	6.4
	6.8	1.1	2.5	1150	34.8	25.2	2.61	13.3	43.7	103.0	5.9	3.8	0.1	0.2	1150	48.5	3.05	4.7	38.1	109.1	70.0	6.2
	9.0	2.3	5.2	920	34.6	23.4	2.36	14.7	42.7	99.5	5.2	3.8	0.1	0.2	920	47.7	3.17	4.4	36.9	118.0	70.0	6.4
	9.0	2.3	5.2	1150	35.5	25.5	2.51	14.1	44.0	99.8	5.4	3.8	0.1	0.2	1150	48.5	3.05	4.7	38.1	109.1	70.0	6.2
100	4.5	0.2	0.5	920	30.6	21.8	2.99	10.3	40.8	118.1	8.2	2.5	0.1	0.2	920	47.7	3.17	4.4	36.9	118.0	70.0	6.4
	4.5	0.2	0.5	1150	31.4	23.7	3.18	9.9	42.2	118.8	8.5	2.5	0.1	0.2	1150	48.5	3.05	4.7	38.1	109.1	70.0	6.2
	6.8	1.1	2.5	920	32.0	22.3	2.76	11.6	41.4	112.3	7.2	2.5	0.1	0.2	920	47.7	3.17	4.4	36.9	118.0	70.0	6.4
	6.8	1.1	2.5	1150	32.8	24.3	2.94	11.1	42.8	112.7	7.4	2.5	0.1	0.2	1150	48.5	3.05	4.7	38.1	109.1	70.0	6.2
	9.0	2.3	5.2	920	32.6	22.6	2.66	12.3	41.7	109.3	6.7	2.5	0.1	0.2	920	47.7	3.17	4.4	36.9	118.0	70.0	6.4
	9.0	2.3	5.2	1150	33.4	24.6	2.83	11.8	43.1	109.6	6.9	2.5	0.1	0.2	1150	48.5	3.05	4.7	38.1	109.1	70.0	6.2
110	4.5	0.2	0.4	920	28.4	20.9	3.38	8.4	40.0	127.8	10.1	1.9	0.1	0.2	920	47.7	3.17	4.4	36.9	118.0	70.0	6.4
	4.5	0.2	0.4	1150	29.1	22.8	3.60	8.1	41.4	128.4	10.4	1.9	0.1	0.2	1150	48.5	3.05	4.7	38.1	109.1	70.0	6.2
	6.8	1.1	2.5	920	29.8	21.5	3.13	9.5	40.5	122.0	8.9	1.9	0.1	0.2	920	47.7	3.17	4.4	36.9	118.0	70.0	6.4
	6.8	1.1	2.5	1150	30.5	23.4	3.33	9.2	41.9	122.4	9.2	1.9	0.1	0.2	1150	48.5	3.05	4.7	38.1	109.1	70.0	6.2
	9.0	2.3	5.2	920	30.5	21.7	3.01	10.1	40.8	119.1	8.3	1.9	0.1	0.2	920	47.7	3.17	4.4	36.9	118.0	70.0	6.4
	9.0	2.3	5.2	1150	31.2	23.7	3.21	9.7	42.2	119.4	8.6	1.9	0.1	0.2	1150	48.5	3.05	4.7	38.1	109.1	70.0	6.2
120												1.5	0.1	0.2	920	47.7	3.17	4.4	36.9	118.0	70.0	6.4
												1.5	0.1	0.2	1150	48.5	3.05	4.7	38.1	109.1	70.0	6.2
	6.8	1.0	2.3	920	27.5	20.6	3.56	7.7	39.7	131.8	10.9	1.5	0.1	0.2	920	47.7	3.17	4.4	36.9	118.0	70.0	6.4
	6.8	1.0	2.3	1150	28.2	22.4	3.79	7.4	41.1	13												

Table 16d: Performance Data — GT-PB/50YF Model 042 - Full Load

Performance capacities shown in thousands of Btuh

Antifreeze use recommended in this range. Also Clip JW3 on DXM2 board.

EWT °F	Cooling - EAT 80/67°F											Heating - EAT 70°F										
	GPM	WPD		CFM	TC	SC	kW	EER	HR	LWT	HWC	GPM	WPD		CFM	HC	kW	COP	HE	LAT	LWT	HWC
		PSI	FT										PSI	FT								
20	2.8	1.5	3.4	1040	48.2	33.2	2.0	24.6	54.9	60.0	1.6	10.5	8.4	19.4	1,040	29.1	2.9	2.9	19.0	96	16.4	3.4
	2.8	1.5	3.4	1300	49.4	36.1	2.1	23.6	56.6	60.0	1.7	10.5	8.4	19.4	1,300	29.6	2.8	3.1	19.9	91	16.2	3.3
30	3.8	1.6	3.6	1040	48.2	33.2	2.0	24.6	54.9	60.0	1.6	5.3	2.7	6.2	1,040	31.8	3.0	3.1	21.5	98	21.8	3.6
	3.8	1.6	3.6	1300	49.4	36.1	2.1	23.6	56.6	60.0	1.7	5.3	2.7	6.2	1,300	32.4	2.9	3.3	22.5	93	21.4	3.4
	3.8	1.6	3.6	1040	48.2	33.2	2.0	24.6	54.9	60.0	1.6	7.9	4.8	11.1	1,040	33.1	3.0	3.2	22.8	100	24.2	3.6
	3.8	1.6	3.6	1300	49.4	36.1	2.1	23.6	56.6	60.0	1.7	7.9	4.8	11.1	1,300	33.7	2.9	3.4	23.7	94	24.0	3.5
	3.8	1.6	3.6	1040	48.2	33.2	2.0	24.6	54.9	60.0	1.6	10.5	7.4	17.0	1,040	33.9	3.1	3.2	23.4	100	25.5	3.7
	3.8	1.6	3.6	1300	49.4	36.1	2.1	23.6	56.6	60.0	1.7	10.5	7.4	17.0	1,300	34.4	2.9	3.4	24.4	95	25.4	3.6
40	5.3	1.8	4.1	1040	48.0	33.0	2.0	24.1	54.8	60.9	1.7	5.3	1.8	4.1	1,040	36.2	3.1	3.4	25.6	102	30.3	3.8
	5.3	1.8	4.1	1300	49.2	35.9	2.1	23.2	56.4	61.5	1.8	5.3	1.8	4.1	1,300	36.9	3.0	3.6	26.6	96	29.9	3.7
	5.7	2.2	5.1	1040	48.2	33.2	2.0	24.6	54.9	60.0	1.6	7.9	4.1	9.5	1,040	37.8	3.2	3.5	27.0	104	33.1	3.9
	5.7	2.2	5.1	1300	49.4	36.1	2.1	23.6	56.6	60.0	1.7	7.9	4.1	9.5	1,300	38.5	3.0	3.7	28.1	97	32.9	3.8
	5.7	2.2	5.1	1040	48.2	33.2	2.0	24.6	54.9	60.0	1.6	10.5	6.4	14.7	1,040	38.6	3.2	3.6	27.8	104	34.7	4.0
	5.7	2.2	5.1	1300	49.4	36.1	2.1	23.6	56.6	60.0	1.7	10.5	6.4	14.7	1,300	39.3	3.1	3.8	28.9	98	34.5	3.9
50	5.3	1.8	4.1	1040	46.6	32.2	2.2	21.4	54.0	70.6	2.2	5.3	1.8	4.1	1,040	40.6	3.2	3.7	29.6	106	38.7	4.2
	5.3	1.8	4.1	1300	47.8	35.0	2.3	20.6	55.7	71.2	2.3	5.3	1.8	4.1	1,300	41.3	3.1	3.9	30.7	99	38.3	4.1
	7.9	3.4	7.9	1040	47.7	32.8	2.0	23.3	54.6	63.9	1.8	7.9	3.4	7.9	1,040	42.4	3.3	3.8	31.2	108	42.1	4.4
	7.9	3.4	7.9	1300	48.8	35.7	2.2	22.5	56.2	64.3	1.9	7.9	3.4	7.9	1,300	43.2	3.2	4.0	32.4	101	41.8	4.2
	10.5	5.4	12.5	1040	48.1	33.1	2.0	24.3	54.9	60.5	1.7	10.5	5.4	12.5	1,040	43.4	3.3	3.8	32.1	109	43.9	4.5
10.5	5.4	12.5	1300	49.3	36.0	2.1	23.4	56.5	60.8	1.7	10.5	5.4	12.5	1,300	44.1	3.2	4.1	33.3	101	43.7	4.3	
60	5.3	1.7	3.9	1040	45.0	31.3	2.4	18.8	53.1	80.2	2.9	5.3	1.7	3.9	1,040	45.0	3.3	3.9	33.6	110	47.2	4.6
	5.3	1.7	3.9	1300	46.1	34.1	2.5	18.1	54.7	80.9	3.0	5.3	1.7	3.9	1,300	45.8	3.2	4.2	34.8	103	46.7	4.5
	7.9	3.2	7.5	1040	46.1	31.9	2.2	20.6	53.8	73.7	2.4	7.9	3.2	7.5	1,040	47.0	3.4	4.0	35.4	112	51.0	4.9
	7.9	3.2	7.5	1300	47.3	34.8	2.4	19.8	55.4	74.1	2.5	7.9	3.2	7.5	1,300	47.8	3.3	4.3	36.6	104	50.7	4.7
	10.5	5.2	11.9	1040	46.7	32.3	2.2	21.6	54.1	70.3	2.2	10.5	5.2	11.9	1,040	48.1	3.4	4.1	36.4	113	53.1	5.0
10.5	5.2	11.9	1300	47.9	35.1	2.3	20.7	55.7	70.6	2.3	10.5	5.2	11.9	1,300	48.9	3.3	4.3	37.6	105	52.8	4.9	
70	5.3	1.6	3.6	1040	43.1	30.4	2.6	16.3	52.1	89.8	3.7	5.3	1.6	3.6	1,040	49.3	3.5	4.2	37.5	114	55.7	5.2
	5.3	1.6	3.6	1300	44.1	33.1	2.8	15.7	53.7	90.5	3.8	5.3	1.6	3.6	1,300	50.1	3.3	4.4	38.8	106	55.2	5.0
	7.9	3.1	7.1	1040	44.4	31.0	2.5	18.0	52.8	83.4	3.1	7.9	3.1	7.1	1,040	51.5	3.5	4.3	39.4	116	60.0	5.5
	7.9	3.1	7.1	1300	45.5	33.8	2.6	17.3	54.4	83.8	3.2	7.9	3.1	7.1	1,300	52.4	3.4	4.5	40.8	107	59.6	5.3
	10.5	4.9	11.3	1040	45.0	31.4	2.4	18.9	53.2	80.1	2.9	10.5	4.9	11.3	1,040	52.6	3.6	4.3	40.5	117	62.3	5.7
10.5	4.9	11.3	1300	46.1	34.1	2.5	18.2	54.8	80.4	3.0	10.5	4.9	11.3	1,300	53.5	3.4	4.6	41.9	108	62.0	5.5	
80	5.3	1.5	3.5	1040	41.0	29.5	2.9	14.1	50.9	99.4	4.6	5.3	1.5	3.5	1,040	53.5	3.6	4.4	41.2	118	64.3	5.8
	5.3	1.5	3.5	1300	42.0	32.2	3.1	13.5	52.6	100.0	4.7	5.3	1.5	3.5	1,300	54.4	3.4	4.6	42.6	109	63.8	5.6
	7.9	3.0	6.9	1040	42.4	30.1	2.7	15.6	51.7	93.1	4.0	7.9	3.0	6.9	1,040	55.8	3.7	4.5	43.3	120	69.0	6.2
	7.9	3.0	6.9	1300	43.5	32.8	2.9	15.0	53.3	93.5	4.1	7.9	3.0	6.9	1,300	56.8	3.5	4.7	44.8	110	68.6	6.0
	10.5	4.8	11.0	1040	43.1	30.4	2.6	16.4	52.1	89.9	3.7	10.5	4.8	11.0	1,040	56.4	3.7	4.5	43.9	120	70.0	6.3
10.5	4.8	11.0	1300	44.2	33.1	2.8	15.8	53.7	90.2	3.8	10.5	4.8	11.0	1,300	57.4	3.5	4.8	45.4	111	70.0	6.1	
90	5.3	1.5	3.4	1040	38.7	28.7	3.2	12.0	49.7	108.9	5.6	4.5	1.2	2.8	1,040	56.4	3.7	4.5	43.9	120	70.0	6.3
	5.3	1.5	3.4	1300	41.2	31.8	3.2	12.8	52.2	109.6	5.1	4.5	1.2	2.8	1,300	57.4	3.5	4.8	45.4	111	70.0	6.1
	7.9	2.9	6.6	1040	40.2	29.3	3.0	13.3	50.5	102.8	4.9	4.5	1.2	2.8	1,040	56.4	3.7	4.5	43.9	120	70.0	6.3
	7.9	2.9	6.6	1300	41.2	31.8	3.2	12.8	52.2	103.3	5.1	4.5	1.2	2.8	1,300	57.4	3.5	4.8	45.4	111	70.0	6.1
	10.5	4.7	10.7	1040	41.0	29.5	2.9	14.1	50.9	99.7	4.6	4.5	1.2	2.8	1,040	56.4	3.7	4.5	43.9	120	70.0	6.3
10.5	4.7	10.7	1300	42.0	32.2	3.1	13.5	52.6	100.0	4.7	4.5	1.2	2.8	1,300	57.4	3.5	4.8	45.4	111	70.0	6.1	
100	5.3	1.4	3.3	1040	36.2	27.9	3.6	10.1	48.5	118.5	6.7	3.0	0.8	1.8	1,040	56.4	3.7	4.5	43.9	120	70.0	6.3
	5.3	1.4	3.3	1300	37.1	30.4	3.8	9.7	50.2	119.1	6.9	3.0	0.8	1.8	1,300	57.4	3.5	4.8	45.4	111	70.0	6.1
	7.9	2.8	6.4	1040	37.8	28.4	3.4	11.3	49.3	112.5	6.0	3.0	0.8	1.8	1,040	56.4	3.7	4.5	43.9	120	70.0	6.3
	7.9	2.8	6.4	1300	38.8	31.0	3.6	10.9	51.0	112.9	6.2	3.0	0.8	1.8	1,300	57.4	3.5	4.8	45.4	111	70.0	6.1
	10.5	4.5	10.4	1040	38.6	28.7	3.2	11.9	49.7	109.5	5.6	3.0	0.8	1.8	1,040	56.4	3.7	4.5	43.9	120	70.0	6.3
10.5	4.5	10.4	1300	39.6	31.2	3.4	11.5	51.4	109.8	5.8	3.0	0.8	1.8	1,300	57.4	3.5	4.8	45.4	111	70.0	6.1	
110	5.3	1.4	3.2	1040	33.6	27.2	4.0	8.4	47.3	128.0	8.0	2.3	0.6	1.3	1,040	56.4	3.7	4.5	43.9	120	70.0	6.3
	5.3	1.4	3.2	1300	34.5	29.6	4.3	8.1	49.0	128.7	8.2	2.3	0.6	1.3	1,300	57.4	3.5	4.8	45.4	111	70.0	6.1
	7.9	2.7	6.2	1040	35.3	27.7	3.7	9.4	48.0	122.2	7.2	2.3	0.6	1.3	1,040	56.4	3.7	4.5	43.9	120	70.0	6.3
	7.9	2.7	6.2	1300	36.2	30.1	4.0	9.1	49.7	122.6	7.4	2.3	0.6	1.3	1,300	57.4	3.5	4.8	45.4	111	70.0	6.1
	10.5	4.4	10.1	1040	36.1	27.9	3.6	10.0	48.4	119.2	6.8	2.3	0.6	1.3	1,040	56.4	3.7	4.5	43.9	120	70.0	6.3
10.5	4.4	10.1	1300	37.0	30.4	3.8	9.6	50.1	119.5	7.0	2.3	0.6	1.3	1,300	57.4	3.5	4.8	45.4	111	70.0	6.1	
120												1.8	0.3	0.8	1,040	56.4	3.7	4.5	43.9	120	70.0	6.3
												1.8	0.3	0.8	1,300	57.4	3.5	4.8	45.4	111	70.0	6.1
	7.9	2.6	6.0	1040	32.6	26.9	4.2	7.8	46.8	131.9	8.5	1.8	0.3	0.8	1,040	56.4	3.7	4.5	43.9	120	70.0	6.3
	7.9	2.6	6.0	1300	33.4	29.3	4.4	7.5	48.5	132.3	8.8	1.8	0.3	0.8	1,300	57.4	3.5	4.8	45.4	111	70.0	6.1
	10.5	4																				

Table 16e: Performance Data — GT-PB/50YF Model 048 - Full Load

Performance capacities shown in thousands of Btuh												Antifreeze use recommended in this range. Also Clip JW3 on DXM2 board.										
EWT °F	Cooling - EAT 80/67°F											Heating - EAT 70°F										
	GPM	WPD		CFM	TC	SC	kW	EER	HR	LWT	HWC	GPM	WPD		CFM	HC	kW	COP	HE	LAT	LWT	HWC
		PSI	FT										PSI	FT								
20	3.1	1.1	2.5	1200	52.8	33.2	2.2	23.9	60.4	60.0	2.4	12.0	7.7	17.8	1,200	31.9	3.0	3.1	21.7	95	16.4	3.6
	3.1	1.1	2.5	1500	54.1	36.1	2.4	23.0	62.2	60.0	2.5	12.0	7.7	17.8	1,500	32.4	2.9	3.3	22.6	90	16.2	3.5
30	4.1	1.2	2.8	1200	52.8	33.2	2.2	23.9	60.4	60.0	2.4	6.0	2.0	4.6	1,200	34.6	3.0	3.3	24.1	97	22.0	3.8
	4.1	1.2	2.8	1500	54.1	36.1	2.4	23.0	62.2	60.0	2.5	6.0	2.0	4.6	1,500	35.2	2.9	3.5	25.1	92	21.6	3.6
	4.1	1.2	2.8	1200	52.8	33.2	2.2	23.9	60.4	60.0	2.4	9.0	4.0	9.2	1,200	35.8	3.1	3.4	25.3	98	24.4	3.8
	4.1	1.2	2.8	1500	54.1	36.1	2.4	23.0	62.2	60.0	2.5	9.0	4.0	9.2	1,500	36.5	3.0	3.6	26.4	93	24.1	3.7
	4.1	1.2	2.8	1200	52.8	33.2	2.2	23.9	60.4	60.0	2.4	12.0	6.5	15.1	1,200	36.6	3.1	3.5	26.0	98	25.7	3.9
	4.1	1.2	2.8	1500	54.1	36.1	2.4	23.0	62.2	60.0	2.5	12.0	6.5	15.1	1,500	37.2	3.0	3.7	27.0	93	25.5	3.8
40	6.0	1.9	4.4	1200	52.8	33.1	2.2	23.7	60.4	60.1	2.5	6.0	1.9	4.4	1,200	39.1	3.1	3.6	28.3	100	30.6	4.0
	6.0	1.9	4.4	1500	54.1	36.1	2.4	22.8	62.2	60.7	2.5	6.0	1.9	4.4	1,500	39.7	3.0	3.9	29.4	95	30.2	3.9
	6.2	2.0	4.7	1200	52.8	33.2	2.2	23.9	60.4	60.0	2.4	9.0	3.8	8.7	1,200	40.7	3.2	3.8	29.8	101	33.4	4.1
	6.2	2.0	4.7	1500	54.1	36.1	2.4	23.0	62.2	60.0	2.5	9.0	3.8	8.7	1,500	41.4	3.1	4.0	30.9	96	33.1	4.0
	6.2	2.0	4.7	1200	52.8	33.2	2.2	23.9	60.4	60.0	2.4	12.0	6.0	13.9	1,200	41.5	3.2	3.8	30.6	102	34.9	4.2
	6.2	2.0	4.7	1500	54.1	36.1	2.4	23.0	62.2	60.0	2.5	12.0	6.0	13.9	1,500	42.3	3.1	4.0	31.8	96	34.7	4.1
50	6.0	1.7	4.0	1200	51.7	32.7	2.4	21.4	60.0	70.0	3.1	6.0	1.7	4.0	1,200	43.8	3.2	4.0	32.7	104	39.1	4.4
	6.0	1.7	4.0	1500	53.0	35.6	2.6	20.5	61.8	70.6	3.2	6.0	1.7	4.0	1,500	44.6	3.1	4.2	33.9	98	38.7	4.2
	9.0	3.4	7.9	1200	52.5	33.0	2.3	23.0	60.3	63.4	2.6	9.0	3.4	7.9	1,200	45.7	3.3	4.1	34.5	105	42.3	4.5
	9.0	3.4	7.9	1500	53.8	36.0	2.4	22.2	62.1	63.8	2.7	9.0	3.4	7.9	1,500	46.5	3.2	4.3	35.7	99	42.1	4.4
	12.0	5.5	12.7	1200	52.8	33.2	2.2	23.8	60.4	60.1	2.4	12.0	5.5	12.7	1,200	46.8	3.3	4.1	35.5	106	44.1	4.6
	12.0	5.5	12.7	1500	54.1	36.1	2.4	22.9	62.2	60.4	2.5	12.0	5.5	12.7	1,500	47.6	3.2	4.4	36.7	99	43.9	4.5
60	6.0	1.6	3.7	1200	50.0	32.1	2.7	18.6	59.2	79.7	3.9	6.0	1.6	3.7	1,200	48.7	3.3	4.3	37.3	108	47.6	4.7
	6.0	1.6	3.7	1500	51.3	34.9	2.9	17.9	61.0	80.3	4.0	6.0	1.6	3.7	1,500	49.5	3.2	4.5	38.5	101	47.2	4.6
	9.0	3.2	7.5	1200	51.2	32.6	2.5	20.5	59.8	73.3	3.3	9.0	3.2	7.5	1,200	50.9	3.4	4.4	39.3	109	51.3	4.9
	9.0	3.2	7.5	1500	52.5	35.4	2.7	19.7	61.6	73.7	3.4	9.0	3.2	7.5	1,500	51.8	3.3	4.7	40.7	102	51.0	4.8
	12.0	5.3	12.2	1200	51.8	32.7	2.4	21.4	60.0	70.0	3.0	12.0	5.3	12.2	1,200	52.1	3.4	4.5	40.5	110	53.3	5.0
	12.0	5.3	12.2	1500	53.0	35.6	2.6	20.6	61.8	70.3	3.1	12.0	5.3	12.2	1,500	53.0	3.3	4.7	41.8	103	53.0	4.9
70	6.0	1.4	3.3	1200	47.9	31.3	3.0	15.9	58.1	89.4	4.8	6.0	1.4	3.3	1,200	53.7	3.5	4.6	41.9	111	56.0	5.2
	6.0	1.4	3.3	1500	49.1	34.0	3.2	15.3	60.0	90.0	5.0	6.0	1.4	3.3	1,500	54.6	3.3	4.8	43.2	104	55.6	5.0
	9.0	3.0	6.9	1200	49.4	31.8	2.8	17.7	58.9	83.1	4.2	9.0	3.0	6.9	1,200	56.2	3.5	4.7	44.2	113	60.2	5.4
	9.0	3.0	6.9	1500	50.6	34.7	3.0	17.1	60.7	83.5	4.3	9.0	3.0	6.9	1,500	57.2	3.4	5.0	45.6	105	59.9	5.3
	12.0	4.9	11.3	1200	50.1	32.1	2.7	18.7	59.2	79.9	3.8	12.0	4.9	11.3	1,200	57.6	3.5	4.8	45.5	114	62.4	5.6
	12.0	4.9	11.3	1500	51.3	34.9	2.9	18.0	61.0	80.2	4.0	12.0	4.9	11.3	1,500	58.6	3.4	5.0	46.9	106	62.2	5.4
80	6.0	1.4	3.3	1200	45.4	30.3	3.4	13.3	57.0	99.0	6.0	6.0	1.4	3.3	1,200	58.6	3.6	4.8	46.5	115	64.5	5.7
	6.0	1.4	3.3	1500	46.5	33.0	3.6	12.8	58.9	99.6	6.2	6.0	1.4	3.3	1,500	59.7	3.4	5.1	47.9	107	64.0	5.5
	9.0	2.9	6.7	1200	47.1	31.0	3.1	15.0	57.8	92.8	5.2	9.0	2.9	6.7	1,200	61.4	3.6	4.9	49.0	117	69.1	6.0
	9.0	2.9	6.7	1500	48.2	33.7	3.3	14.4	59.6	93.2	5.4	9.0	2.9	6.7	1,500	62.5	3.5	5.2	50.5	109	68.8	5.8
	12.0	4.8	11.1	1200	47.9	31.3	3.0	15.9	58.1	89.7	4.8	10.2	3.6	8.3	1,200	62.1	3.7	5.0	49.6	118	70.0	6.1
	12.0	4.8	11.1	1500	49.1	34.0	3.2	15.3	60.0	90.0	5.0	10.2	3.6	8.3	1,500	63.2	3.5	5.3	51.2	109	70.0	5.9
90	6.0	1.3	3.1	1200	42.8	29.3	3.9	11.1	55.9	108.6	7.3	5.1	1.1	2.5	1,200	62.1	3.7	5.0	49.6	118	70.0	6.1
	6.0	1.3	3.1	1500	45.6	32.6	3.8	12.0	58.5	109.3	6.6	5.1	1.1	2.5	1,500	63.2	3.5	5.3	51.2	109	70.0	5.9
	9.0	2.8	6.5	1200	44.5	30.0	3.6	12.5	56.6	102.6	6.4	5.1	1.1	2.5	1,200	62.1	3.7	5.0	49.6	118	70.0	6.1
	9.0	2.8	6.5	1500	45.6	32.6	3.8	12.0	58.5	103.0	6.6	5.1	1.1	2.5	1,500	63.2	3.5	5.3	51.2	109	70.0	5.9
	12.0	4.7	10.9	1200	45.4	30.3	3.4	13.3	57.0	99.5	6.0	5.1	1.1	2.5	1,200	62.1	3.7	5.0	49.6	118	70.0	6.1
	12.0	4.7	10.9	1500	46.5	33.0	3.6	12.8	58.9	99.8	6.2	5.1	1.1	2.5	1,500	63.2	3.5	5.3	51.2	109	70.0	5.9
100	6.0	1.3	3.0	1200	40.0	28.2	4.4	9.1	55.0	118.3	8.9	3.4	0.6	1.4	1,200	62.1	3.7	5.0	49.6	118	70.0	6.1
	6.0	1.3	3.0	1500	41.0	30.7	4.7	8.8	57.0	119.0	9.2	3.4	0.6	1.4	1,500	63.2	3.5	5.3	51.2	109	70.0	5.9
	9.0	2.7	6.1	1200	41.8	28.9	4.0	10.3	55.6	112.3	7.9	3.4	0.6	1.4	1,200	62.1	3.7	5.0	49.6	118	70.0	6.1
	9.0	2.7	6.1	1500	42.8	31.5	4.3	9.9	57.5	112.8	8.1	3.4	0.6	1.4	1,500	63.2	3.5	5.3	51.2	109	70.0	5.9
	12.0	4.5	10.4	1200	42.7	29.3	3.9	11.0	55.9	109.3	7.4	3.4	0.6	1.4	1,200	62.1	3.7	5.0	49.6	118	70.0	6.1
	12.0	4.5	10.4	1500	43.7	31.8	4.1	10.6	57.8	109.6	7.6	3.4	0.6	1.4	1,500	63.2	3.5	5.3	51.2	109	70.0	5.9
110	6.0	1.2	2.8	1200	37.4	27.2	5.0	7.5	54.4	128.1	10.6	2.6	0.4	0.9	1,200	62.1	3.7	5.0	49.6	118	70.0	6.1
	6.0	1.2	2.8	1500	38.3	29.5	5.3	7.2	56.5	128.8	11.0	2.6	0.4	0.9	1,500	63.2	3.5	5.3	51.2	109	70.0	5.9
	9.0	2.6	5.9	1200	39.0	27.8	4.6	8.5	54.7	122.2	9.5	2.6	0.4	0.9	1,200	62.1	3.7	5.0	49.6	118	70.0	6.1
	9.0	2.6	5.9	1500	40.0	30.3	4.9	8.2	56.7	122.6	9.8	2.6	0.4	0.9	1,500	63.2	3.5	5.3	51.2	109	70.0	5.9
	12.0	4.4	10.1	1200	39.9	28.2	4.4	9.0	55.0	119.2	9.0	2.6	0.4	0.9	1,200	62.1	3.7	5.0	49.6	118	70.0	6.1
	12.0	4.4	10.1	1500	40.9	30.6	4.7	8.7	56.9	119.5	9.2	2.6	0.4	0.9	1,500	63.2	3.5	5.3	51.2	109	70.0	5.9
120												2.0	0.2	0.4	1,200	62.1	3.7	5.0	49.6	118	70.0	6.1
												2.0	0.2	0.4	1,500	63.2	3.5	5.3	51.2	109	70.0	5.9
												2.0	0.2	0.4	1,200	62.1	3.7	5.0	49.6	118	70.0	6.1
												2.0	0.2	0.4	1,500	63.2	3.5	5.3	51.2	109	70.0	5.9
												2.0	0.2	0.4	1,200	62.1	3.7	5.0	49.6	118	70.0	6.1
												2.0										

Table 16f: Performance Data — GT-PB/50YF Model 060 - Full Load

Performance capacities shown in thousands of Btuh												Antifreeze use recommended in this range. Also Clip JW3 on DXM2 board.										
EWT °F	Cooling - EAT 80/67°F											Heating - EAT 70°F										
	GPM	WPD		CFM	TC	SC	kW	EER	HR	LWT	HWC	GPM	WPD		CFM	HC	kW	COP	HE	LAT	LWT	HWC
		PSI	FT										PSI	FT								
20	4.0	3.1	7.1	1520	67.8	44.9	2.8	24.2	77.3	60.0	2.4	14.0	14.5	33.5	1,520	40.5	4.1	2.9	27	94.7	16	4.7
	4.0	3.1	7.1	1900	69.4	48.8	3.0	23.3	79.6	60.0	2.5	14.0	14.5	33.5	1,900	41.2	3.9	3.1	28	90.1	16	4.5
30	5.3	3.3	7.5	1520	67.8	44.9	2.8	24.2	77.3	60.0	2.4	7.0	5.0	11.5	1,520	44.2	4.1	3.1	30	96.9	21	4.8
	5.3	3.3	7.5	1900	69.4	48.8	3.0	23.3	79.6	60.0	2.5	7.0	5.0	11.5	1,900	45.0	4.0	3.3	31	91.9	21	4.7
	5.3	3.3	7.5	1520	67.8	44.9	2.8	24.2	77.3	60.0	2.4	10.5	8.5	19.7	1,520	46.1	4.2	3.2	32	98.1	24	4.9
	5.3	3.3	7.5	1900	69.4	48.8	3.0	23.3	79.6	60.0	2.5	10.5	8.5	19.7	1,900	46.9	4.0	3.4	33	92.9	24	4.8
	5.3	3.3	7.5	1520	67.8	44.9	2.8	24.2	77.3	60.0	2.4	14.0	13.2	30.4	1,520	47.1	4.2	3.3	33	98.7	25	5.0
	5.3	3.3	7.5	1900	69.4	48.8	3.0	23.3	79.6	60.0	2.5	14.0	13.2	30.4	1,900	48.0	4.1	3.5	34	93.4	25	4.8
40	7.0	4.0	9.2	1520	67.3	44.5	2.8	23.7	77.0	62.6	2.6	7.0	4.0	9.3	1,520	50.2	4.3	3.4	36	100.6	30	5.2
	7.0	4.0	9.2	1900	68.9	48.5	3.0	22.8	79.2	62.6	2.6	7.0	4.0	9.3	1,900	51.1	4.1	3.6	37	94.9	29	5.0
	8.0	4.6	10.7	1520	67.8	44.9	2.8	24.2	77.3	60.0	2.4	10.5	7.1	16.5	1,520	52.4	4.4	3.5	38	101.9	33	5.3
	8.0	4.6	10.7	1900	69.4	48.8	3.0	23.3	79.6	60.0	2.5	10.5	7.1	16.5	1,900	53.4	4.2	3.7	39	96.0	33	5.2
	8.0	4.6	10.7	1520	67.8	44.9	2.8	24.2	77.3	60.0	2.4	14.0	11.1	25.6	1,520	53.7	4.4	3.6	39	102.7	34	5.4
	8.0	4.6	10.7	1900	69.4	48.8	3.0	23.3	79.6	60.0	2.5	14.0	11.1	25.6	1,900	54.6	4.2	3.8	40	96.6	34	5.2
50	7.0	3.1	7.2	1520	65.1	43.4	3.0	21.5	75.4	71.6	3.2	7.0	3.1	7.2	1,520	56.2	4.5	3.7	41	104.2	38	5.6
	7.0	3.1	7.2	1900	66.7	47.3	3.2	20.6	77.7	72.2	3.3	7.0	3.1	7.2	1,900	57.2	4.3	3.9	43	97.9	38	5.4
	10.5	5.8	13.3	1520	66.8	44.3	2.9	23.2	76.6	65.0	2.7	10.5	5.8	13.3	1,520	58.7	4.5	3.8	43	105.8	42	5.8
	10.5	5.8	13.3	1900	68.4	48.2	3.1	22.3	78.9	65.0	2.8	10.5	5.8	13.3	1,900	59.7	4.4	4.0	45	99.1	41	5.6
	14.0	9.0	20.9	1520	67.5	44.7	2.8	23.9	77.1	61.3	2.5	14.0	9.0	20.9	1,520	60.1	4.6	3.9	44	106.6	44	5.9
	14.0	9.0	20.9	1900	69.2	48.6	3.0	23.0	79.4	61.3	2.6	14.0	9.0	20.9	1,900	61.1	4.4	4.1	46	99.8	43	5.7
60	7.0	2.9	6.8	1520	62.5	42.4	3.3	18.9	73.8	81.1	4.0	7.0	2.9	6.8	1,520	62.1	4.6	3.9	46	107.8	47	6.1
	7.0	2.9	6.8	1900	64.0	46.1	3.5	18.2	76.0	81.7	4.1	7.0	2.9	6.8	1,900	63.1	4.4	4.2	48	100.8	46	5.9
	10.5	5.5	12.7	1520	64.4	43.2	3.1	20.8	75.0	74.3	3.4	10.5	5.5	12.7	1,520	64.9	4.7	4.0	49	109.5	51	6.3
	10.5	5.5	12.7	1900	66.0	47.0	3.3	20.0	77.3	74.7	3.5	10.5	5.5	12.7	1,900	66.0	4.5	4.3	51	102.2	50	6.1
	14.0	8.7	20.1	1520	65.4	43.6	3.0	21.7	75.6	70.8	3.1	14.0	8.7	20.1	1,520	66.4	4.7	4.1	50	110.4	53	6.5
	14.0	8.7	20.1	1900	67.0	47.4	3.2	20.9	77.9	71.1	3.2	14.0	8.7	20.1	1,900	67.5	4.6	4.3	52	102.9	53	6.3
70	7.0	2.8	6.5	1520	59.6	41.4	3.6	16.4	72.1	90.6	5.0	7.0	2.8	6.5	1,520	67.8	4.8	4.2	52	111.3	55	6.6
	7.0	2.8	6.5	1900	61.1	45.0	3.9	15.8	74.3	91.2	5.2	7.0	2.8	6.5	1,900	69.0	4.6	4.4	53	103.6	55	6.4
	10.5	5.2	12.1	1520	61.7	42.1	3.4	18.2	73.3	84.0	4.3	10.5	5.2	12.1	1,520	70.9	4.9	4.3	54	113.2	60	6.9
	10.5	5.2	12.1	1900	63.2	45.8	3.6	17.5	75.6	84.4	4.4	10.5	5.2	12.1	1,900	72.1	4.7	4.5	56	105.2	59	6.7
	14.0	8.3	19.3	1520	62.7	42.5	3.3	19.1	73.9	80.6	3.9	14.0	8.3	19.3	1,520	72.5	4.9	4.3	56	114.2	62	7.1
	14.0	8.3	19.3	1900	64.3	46.2	3.5	18.4	76.2	80.9	4.1	14.0	8.3	19.3	1,900	73.8	4.7	4.6	58	106.0	62	6.9
80	7.0	2.7	6.2	1520	56.6	40.2	4.0	14.0	70.4	100.1	6.2	7.0	2.7	6.2	1,520	73.5	4.9	4.4	57	114.8	64	7.3
	7.0	2.7	6.2	1900	58.0	43.7	4.3	13.5	72.7	100.8	6.4	7.0	2.7	6.2	1,900	74.8	4.8	4.6	59	106.5	63	7.0
	10.5	5.0	11.6	1520	58.7	41.0	3.8	15.6	71.6	93.6	5.3	10.5	5.0	11.6	1,520	76.8	5.0	4.5	60	116.8	68	7.7
	10.5	5.0	11.6	1900	60.2	44.6	4.0	15.0	73.8	94.1	5.5	10.5	5.0	11.6	1,900	78.2	4.8	4.7	62	108.1	68	7.4
	14.0	8.1	18.6	1520	59.8	41.4	3.6	16.5	72.2	90.3	4.9	12.5	6.6	15.1	1,520	77.9	5.1	4.5	61	117.5	70	7.7
	14.0	8.1	18.6	1900	61.3	45.1	3.9	15.9	74.4	90.6	5.1	12.5	6.6	15.1	1,900	79.3	4.9	4.8	63	108.6	70	7.5
90	7.0	2.6	5.9	1520	53.5	38.9	4.5	11.9	68.9	109.7	7.5	6.3	2.3	5.2	1,520	77.9	5.1	4.5	61	117.5	70	7.7
	7.0	2.6	5.9	1900	57.0	43.3	4.5	12.8	72.2	110.3	6.8	6.3	2.3	5.2	1,900	79.3	4.9	4.8	63	108.6	70	7.5
	10.5	4.8	11.2	1520	55.6	39.8	4.2	13.3	69.9	103.3	6.6	6.3	2.3	5.2	1,520	77.9	5.1	4.5	61	117.5	70	7.7
	10.5	4.8	11.2	1900	57.0	43.3	4.5	12.8	72.2	103.8	6.8	6.3	2.3	5.2	1,900	79.3	4.9	4.8	63	108.6	70	7.5
	14.0	7.8	18.0	1520	56.7	40.2	4.0	14.1	70.5	100.1	6.1	6.3	2.3	5.2	1,520	77.9	5.1	4.5	61	117.5	70	7.7
	14.0	7.8	18.0	1900	58.1	43.8	4.3	13.5	72.7	100.4	6.3	6.3	2.3	5.2	1,900	79.3	4.9	4.8	63	108.6	70	7.5
100	7.0	2.5	5.7	1520	50.5	37.5	5.0	10.1	67.7	119.3	9.1	4.2	1.3	3.0	1,520	77.9	5.1	4.5	61	117.5	70	7.7
	7.0	2.5	5.7	1900	51.8	40.8	5.3	9.7	70.0	120.0	9.4	4.2	1.3	3.0	1,900	79.3	4.9	4.8	63	108.6	70	7.5
	10.5	4.7	10.9	1520	52.5	38.5	4.7	11.3	68.5	113.0	8.0	4.2	1.3	3.0	1,520	77.9	5.1	4.5	61	117.5	70	7.7
	10.5	4.7	10.9	1900	53.8	41.9	5.0	10.8	70.8	113.5	8.3	4.2	1.3	3.0	1,900	79.3	4.9	4.8	63	108.6	70	7.5
	14.0	7.6	17.5	1520	53.6	38.9	4.5	11.9	68.9	109.8	7.5	4.2	1.3	3.0	1,520	77.9	5.1	4.5	61	117.5	70	7.7
	14.0	7.6	17.5	1900	54.9	42.4	4.8	11.5	71.2	110.2	7.7	4.2	1.3	3.0	1,900	79.3	4.9	4.8	63	108.6	70	7.5
110	7.0	2.4	5.6	1520	47.8	36.0	5.6	8.6	66.9	129.1	10.8	3.1	0.8	1.8	1,520	77.9	5.1	4.5	61	117.5	70	7.7
	7.0	2.4	5.6	1900	49.0	39.1	5.9	8.2	69.3	129.8	11.2	3.1	0.8	1.8	1,900	79.3	4.9	4.8	63	108.6	70	7.5
	10.5	4.6	10.6	1520	49.6	37.0	5.2	9.5	67.3	122.8	9.6	3.1	0.8	1.8	1,520	77.9	5.1	4.5	61	117.5	70	7.7
	10.5	4.6	10.6	1900	50.8	40.2	5.5	9.2	69.7	123.3	10.0	3.1	0.8	1.8	1,900	79.3	4.9	4.8	63	108.6	70	7.5
	14.0	7.4	17.1	1520	50.6	37.5	5.0	10.1	67.7	119.7	9.1	3.1	0.8	1.8	1,520	77.9	5.1	4.5	61	117.5	70	7.7
	14.0	7.4	17.1	1900	51.8	40.8	5.3	9.7	70.0	120.0	9.4	3.1	0.8	1.8	1,900	79.3	4.9	4.8	63	108.6	70	7.5
120	7.0	2.3	5.4	1520	45.5	34.4	6.2	7.3	66.6	139.0	12.8	2.5	0.2	0.4	1,520	77.9	5.1	4.5	61	117.5	70	7.7
	7.0	2.3	5.4	1900	46.6	37.4	6.6	7.1	69.1	139.7	13.2	2.5	0.2	0.4	1,900	79.3	4.9	4.8	63	108.6	70	7.5
	10.5	4.4	10.2	1520	47.0	35.4	5.8	8.1	66.7	132.7	11.5	2.5	0.2	0.4	1,520	77.9	5.1	4.5	61	117.5	70	7.7
	10.5	4.4																				

Preventive Maintenance

Water Coil Maintenance

(Direct ground water applications only) - If the system is installed in an area with a known high mineral content (125 P.P.M. or greater) in the water, it is best to establish a periodic maintenance schedule with the owner so the coil can be checked regularly. Consult the well water applications section of this manual for a more detailed water coil material selection. Should periodic coil cleaning be necessary, use standard coil cleaning procedures, which are compatible with the heat exchanger material and copper water lines. Generally, the more water flowing through the unit, the less chance for scaling. Therefore, 1.5 gpm per ton [2.0 l/m per kW] is recommended as a minimum flow. Minimum flow rate for entering water temperatures below 50°F [10°C] is 2.0 gpm per ton [2.6 l/m per kW].

Water Coil Maintenance

(All other water loop applications)
Generally water coil maintenance is not needed for closed loop systems. However, if the piping is known to have high dirt or debris content, it is best to establish a periodic maintenance schedule with the owner so the water coil can be checked regularly. Should periodic coil cleaning be necessary, use standard coil cleaning procedures, which are compatible with both the heat exchanger material and copper water lines. Generally, the more water flowing through the unit, the less chance for scaling. However, flow rates over 3 gpm per ton (3.9 l/m per kW) may produce water (or debris) velocities that can erode the heat exchanger wall and ultimately produce leaks.

Hot Water Generator Coils

See water coil maintenance for ground water units. If the potable water is hard or not chemically softened, the high temperatures of the desuperheater will tend to scale even quicker than the water coil and may need more frequent inspections. In areas with extremely hard water, a HWG is not recommended.

Filters

Filters must be clean to obtain maximum performance. Filters should be inspected every month under normal operating conditions and be replaced when necessary. Units should never be operated without a filter.

Washable, high efficiency, electrostatic filters, when dirty, can exhibit a very high pressure drop for the fan motor and reduce air flow, resulting in poor performance. It is especially important to provide consistent washing of these filters (in the opposite direction of the normal air flow) once per month using a high pressure wash similar to those found at self-serve car washes.

Condensate Drain

In areas where airborne bacteria may produce a "slimy" substance in the drain pan, it may be necessary to treat the drain pan chemically with an algacide approximately every

three months to minimize the problem. The condensate pan may also need to be cleaned periodically to insure indoor air quality. The condensate drain can pick up lint and dirt, especially with dirty filters. Inspect the drain twice a year to avoid the possibility of plugging and eventual overflow.

Compressor

Conduct annual amperage checks to insure that amp draw is no more than 10% greater than indicated on the serial plate data.

Fan Motors

All residential units have permanently lubricated fan motors. Further lubrication is not recommended. Conduct annual amperage check to insure amp draw is no more than 10% greater than indicated on serial data plate.

Air Coil

The air coil must be cleaned to obtain maximum performance. Check once a year under normal operating conditions and, if dirty, brush or vacuum clean. Care must be taken not to damage the aluminum fins while cleaning. CAUTION: Fin edges are sharp.

Cabinet

Do not allow water to stay in contact with the cabinet for long periods of time to prevent corrosion of the cabinet sheet metal. Generally, vertical cabinets are set up from the floor a few inches [7 - 8 cm] to prevent water from entering the cabinet. The cabinet can be cleaned using a mild detergent.

Refrigerant System

To maintain sealed circuit integrity, do not install service gauges unless unit operation appears abnormal. Reference the operating charts for pressures and temperatures. Verify that air and water flow rates are at proper levels before servicing the refrigerant circuit.

Troubleshooting

General

If operational difficulties are encountered, perform the preliminary checks below before referring to the troubleshooting charts.

- Verify that the unit is receiving electrical supply power.
- Make sure the fuses in the fused disconnect switches are intact.

After completing the preliminary checks described above, inspect for other obvious problems such as leaking connections, broken or disconnected wires, etc. If everything appears to be in order, but the unit still fails to operate properly, refer to the “DXM2 Troubleshooting Process Flowchart” or “Functional Troubleshooting Chart.”

DXM2 Board

DXM2 board troubleshooting in general is best summarized as verifying inputs and outputs. After inputs and outputs have been verified, board operation is confirmed and the problem must be elsewhere. Below are some general guidelines for troubleshooting the DXM2 control.

Field Inputs

Conventional thermostat inputs are 24VAC from the thermostat and can be verified using a voltmeter between C and Y1, Y2, W, O, G. 24VAC will be present at the terminal (for example, between “Y1” and “C”) if the thermostat is sending an input to the DXM2 board.

Proper communications with a thermostat can be verified using the Fault LED on the DXM2. If the control is NOT in the Test mode and is NOT currently locked out or in a retry delay, the Fault LED on the DXM2 will flash very slowly (1 second on, 5 seconds off), if the DXM2 is properly communicating with the thermostat.

Sensor Inputs

All sensor inputs are ‘paired wires’ connecting each component to the board. Therefore, continuity on pressure switches, for example can be checked at the board connector. The thermistor resistance should be measured with the connector removed so that only the impedance of the thermistor is measured. If desired, this reading can be compared to the thermistor resistance chart shown in Table 17. An ice bath can be used to check the calibration of the thermistor.

Table 18: Nominal resistance at various temperatures

Temp (°C)	Temp (°F)	Resistance (kOhm)	Temp (°C)	Temp (°F)	Resistance (kOhm)
-17.8	0.0	85.34	55	131.0	2.99
-17.5	0.5	84.00	56	132.8	2.88
-16.9	1.5	81.38	57	134.6	2.77
-12	10.4	61.70	58	136.4	2.67
-11	12.2	58.40	59	138.2	2.58
-10	14.0	55.30	60	140.0	2.49
-9	15.8	52.38	61	141.8	2.40
-8	17.6	49.64	62	143.6	2.32
-7	19.4	47.05	63	145.4	2.23
-6	21.2	44.61	64	147.2	2.16
-5	23.0	42.32	65	149.0	2.08
-4	24.8	40.15	66	150.8	2.01
-3	26.6	38.11	67	152.6	1.94
-2	28.4	36.18	68	154.4	1.88
-1	30.2	34.37	69	156.2	1.81
0	32.0	32.65	70	158.0	1.75
1	33.8	31.03	71	159.8	1.69
2	35.6	29.50	72	161.6	1.64
3	37.4	28.05	73	163.4	1.58
4	39.2	26.69	74	165.2	1.53
5	41.0	25.39	75	167.0	1.48
6	42.8	24.17	76	168.8	1.43
7	44.6	23.02	77	170.6	1.39
8	46.4	21.92	78	172.4	1.34
9	48.2	20.88	79	174.2	1.30
10	50.0	19.90	80	176.0	1.26
11	51.8	18.97	81	177.8	1.22
12	53.6	18.09	82	179.6	1.18
13	55.4	17.26	83	181.4	1.14
14	57.2	16.46	84	183.2	1.10
15	59.0	15.71	85	185.0	1.07
16	60.8	15.00	86	186.8	1.04
17	62.6	14.32	87	188.6	1.01
18	64.4	13.68	88	190.4	0.97
19	66.2	13.07	89	192.2	0.94
20	68.0	12.49	90	194.0	0.92
21	69.8	11.94	91	195.8	0.89
22	71.6	11.42	92	197.6	0.86
23	73.4	10.92	93	199.4	0.84
24	75.2	10.45	94	201.2	0.81
25	77.0	10.00	95	203.0	0.79
26	78.8	9.57	96	204.8	0.76
27	80.6	9.16	97	206.6	0.74
28	82.4	8.78	98	208.4	0.72
29	84.2	8.41	99	210.2	0.70
30	86.0	8.06	100	212.0	0.68
31	87.8	7.72	101	213.8	0.66
32	89.6	7.40	102	215.6	0.64
33	91.4	7.10	103	217.4	0.62
34	93.2	6.81	104	219.2	0.60
35	95.0	6.53	105	221.0	0.59
36	96.8	6.27	106	222.8	0.57
37	98.6	6.01	107	224.6	0.55
38	100.4	5.77	108	226.4	0.54
39	102.2	5.54	109	228.2	0.52
40	104.0	5.33	110	230.0	0.51
41	105.8	5.12	111	231.8	0.50
42	107.6	4.92	112	233.6	0.48
43	109.4	4.72	113	235.4	0.47
44	111.2	4.54	114	237.2	0.46
45	113.0	4.37	115	239.0	0.44
46	114.8	4.20	116	240.8	0.43
47	116.6	4.04	117	242.6	0.42
48	118.4	3.89	118	244.4	0.41
49	120.2	3.74	119	246.2	0.40
50	122.0	3.60	120	248.0	0.39
51	123.8	3.47	121	249.8	0.38
52	125.6	3.34	122	251.6	0.37
53	127.4	3.22	123	253.4	0.36
54	129.2	3.10			

Troubleshooting

Outputs

The compressor and reversing valve relays are 24VAC and can be verified using a voltmeter. For units with ECM blower motors, the DXM2 controls the motor using serial communications, and troubleshooting should be done with a communicating thermostat or diagnostic tool. The alarm relay can either be 24VAC as shipped or dry contacts for use with DDC controls by clipping the JW1 jumper. Electric heat outputs are 24VDC “ground sinking” and require a voltmeter set for DC to verify operation. The terminal marked “24VDC” is the 24VDC supply to the electric heat board; terminal “EH1” is stage 1 electric heat; terminal “EH2” is stage 2 electric heat. When electric heat is energized (thermostat is sending a “W” input to the DXM2 controller), there will be 24VDC between terminal “24VDC” and “EH1” (stage 1 electric heat) and/or “EH2” (stage 2 electric heat). A reading of 0VDC between “24VDC” and “EH1” or “EH2” will indicate that the DXM2 board is NOT sending an output signal to the electric heat board.

Test Mode

Test mode can be entered for 20 minutes by pressing the Test pushbutton. The DXM2 board will automatically exit test mode after 20 minutes.

Advanced Diagnostics

To properly troubleshoot advanced control features, and to aid in troubleshooting basic control features, a communicating thermostat or diagnostic tool must be used.

Service Mode

The Service Mode provides the installer with several functions for troubleshooting, including Manual Operation, Control Diagnostics, Control Configuration, and Fault History.

Manual Operation – The Manual Operation mode allows the installer to bypass normal thermostat timings and operating modes, to directly activate the thermostat inputs to the DXM2, activate the DXM2 Test mode, and directly control the ECM blower, internal flow center, and proportional valve.

Control Diagnostics – The Control Diagnostics menus allow the installer to see the current status of all DXM2 control switch inputs, values of all temperature sensor inputs, control voltage, ECM blower, internal flow center, and proportional valve operating status and parameters.

Dipswitch Configuration – The Dipswitch Configuration menus allow the installer to easily see the current DXM2 control configuration.

Fault History – In addition to the fault code, the DXM2 stores the status of all control inputs and outputs when a fault condition is detected. The fault history covering the last five lockout conditions is stored and may be retrieved from the DXM2. After a specific fault in the fault history is selected, the operating mode and time when the fault occurred are displayed, with options to select specific control status

values when the lockout occurred.

Fault Temp Conditions – This option displays the DXM2 temperature and voltage values when the lockout occurred.

Fault Flow Conditions – This option displays the DXM2 ECM blower, pump, and valve operating parameters when the lockout occurred.

Fault I/O Conditions – This option displays the status of the DXM2 physical and communicated inputs and the relay outputs when the lockout occurred.

Fault Configuration Conditions – This option displays the status of the DXM2 option selections when the lockout occurred.

Fault Possible Causes – This option displays a list of potential causes of the stored fault.

Clear Fault History – The Clear Fault History option allows the fault history stored in the non-volatile memory of the DXM2 to be cleared.

DXM2 Troubleshooting Process Flowchart/Functional Troubleshooting Chart

The “DXM2 Functional Troubleshooting Process Flowchart” is a quick overview of how to start diagnosing a suspected problem, using the fault recognition features of the DXM2 board. The “Functional Troubleshooting Chart” on the following page is a more comprehensive method for identifying a number of malfunctions that may occur, and is not limited to just the DXM2 controls. Within the chart are five columns:

- The “Fault” column describes the symptoms.
- Columns 2 and 3 identify in which mode the fault is likely to occur, heating or cooling.
- The “Possible Cause column” identifies the most likely sources of the problem.
- The “Solution” column describes what should be done to correct the problem.

⚠ WARNING! ⚠

WARNING! HAZARDOUS VOLTAGE! DISCONNECT ALL ELECTRIC POWER INCLUDING REMOTE DISCONNECTS BEFORE SERVICING.
Failure to disconnect power before servicing can cause severe personal injury or death.

DXM2 Process Flow Chart

⚠ WARNING! ⚠
WARNING! HAZARDOUS VOLTAGE! DISCONNECT ALL ELECTRIC POWER INCLUDING REMOTE DISCONNECTS BEFORE SERVICING.
 Failure to disconnect power before servicing can cause severe personal injury or death.

DXM2 Functional Troubleshooting Flow Chart

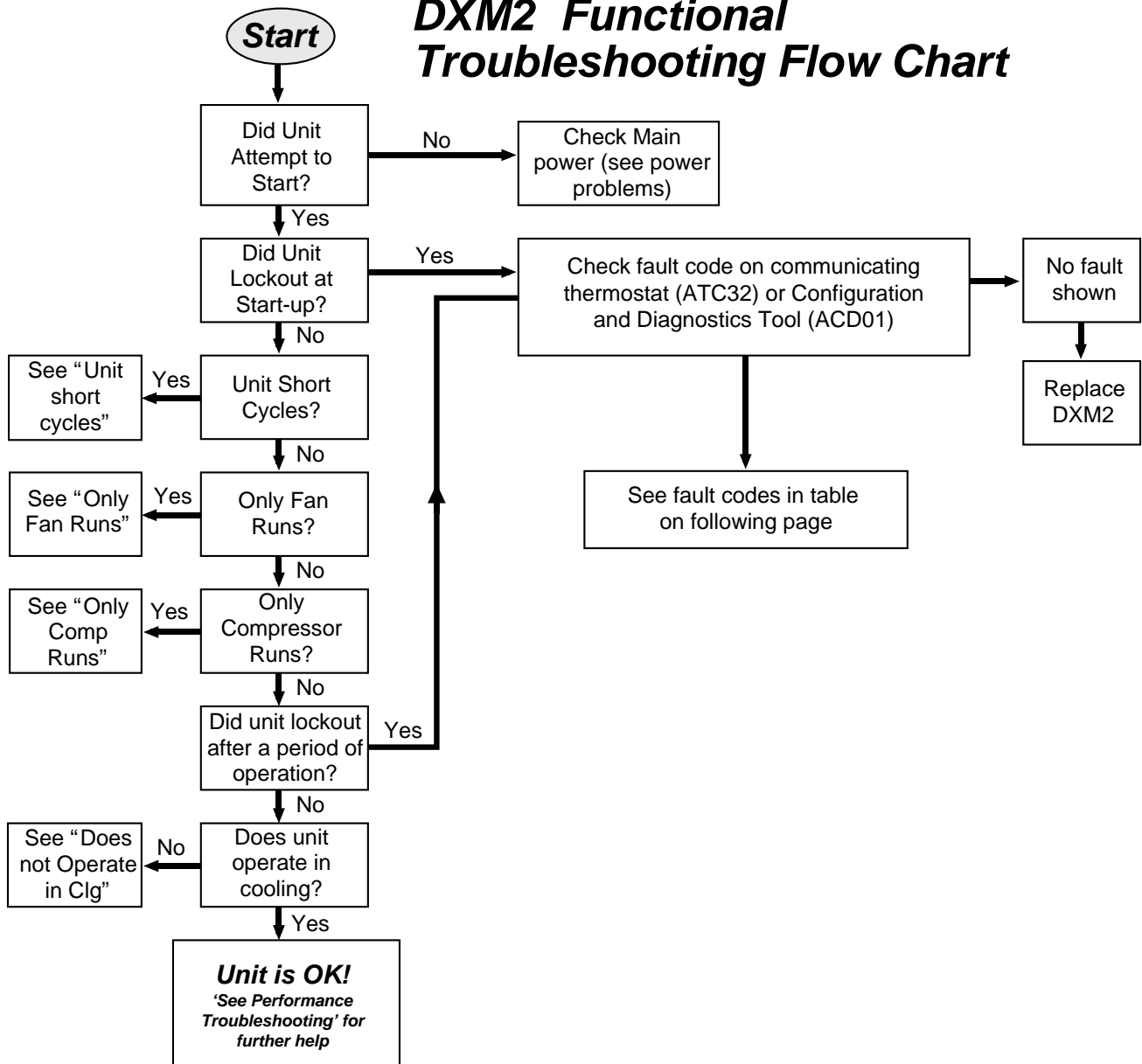

Functional Troubleshooting

Fault	Htg	Clg	Possible Cause	Solution
Main Power Problems	X	X	Green status LED off	Check Line Voltage circuit breaker and disconnect
				Check for line voltage between L1 and L2 on the contactor
HP Fault Code 2 High Pressure		X	Reduced or no water flow in cooling	Check for 24VAC between R and C on DXM
				Check primary/secondary voltage on transformer
	X		Water temperature out of range in cooling	Check pump operation or valve operation/setting
				Check water flow adjust to proper flow rate
	X		Reduced or no air flow in heating	Bring water temp within design parameters
				Check for dirty air filter and clean or replace
	X	X	Overcharged with refrigerant	Check fan motor operation and airflow restrictions
				Dirty air coil- construction dust etc.
	X	X	Bad HP switch	Too high of external static. Check static vs blower table
				Bring return air temp within design parameters
X	X	Frozen water heat exchanger	Check superheat/subcooling vs typical operating condition table	
			Thaw heat exchanger	
X	X	Bad HPWS Switch	Replace HPWS Switch	
			Check switch continuity and operation - Replace	
LP/LOC Fault-Code 3 Low Pressure/Loss of Charge	X	X	Insufficient charge	Check for refrigerant leaks
				Compressor pump down at start-up
LT1 Fault - Code 4 Water Low Temperature	X		Reduced or no water flow in heating	Check charge and start-up water flow
				Check pump operation or water valve operation/setting
	X		Inadequate anti-freeze level	Plugged strainer or filter - clean or replace
				Check water flow adjust to proper flow rate
	X	X	Bad thermistor	Check antifreeze density with hydrometer
Clip LT1 jumper for antifreeze (10°F) use				
LT2 Fault - Code 5 Low Air Temperature		X	Reduced or no air flow in cooling	Bring water temp within design parameters
				Check temp and impedance correlation per chart
	X	X	Bad thermistor	Check for dirty air filter and clean or replace
				Check fan motor operation and airflow restrictions
X	X	Improper low temperature setting (30°F vs 10°F)	Too high of external static - check static vs blower table	
			Too much cold vent air - bring entering air temp within design parameters	
Condensate Fault-Code 6 High Condensate Level	X	X	Blocked drain	Normal airside applications will require 30°F only
				Check temp and impedance correlation per chart
	X	X	Improper trap	Check for blockage and clean drain
				Check trap dimensions and location ahead of vent
	X	X	Poor drainage	Check for piping slope away from unit
				Check slope of unit toward outlet
	X	X	Moisture on sensor	Poor venting - check vent location
Check for moisture shorting to air coil				
X	X	Plugged air filter	Replace air filter	
			Find and eliminate restriction - increase return duct and/or grille size	
Over/Under Voltage-Code 7 (Auto Resetting)	X	X	Under voltage	Check power supply and 24VAC voltage before and during operation
				Check power supply wire size
	X	X	Over voltage	Check compressor starting. Need hard start kit?
				Check 24VAC and unit transformer tap for correct power supply voltage
X	X	Over voltage	Check power supply voltage and 24VAC before and during operation.	
			Check 24VAC and unit transformer tap for correct power supply voltage	

Functional Troubleshooting (cont.)

Fault	Htg	Clg	Possible Cause	Solution
Unit Performance Sentinel-Code 8	X		Heating Mode LT2>125°F	Check for poor air flow or overcharged unit
		X	Cooling Mode LT1>125°F OR LT2< 40°F	Check for poor water flow, or air flow
Swapped Thermistor Code 9	X	X	LT1 and LT2 swapped	Reverse position of thermistors
ECM Fault - Code 10	X	X	Blower does not operate	Check blower line voltage Check blower low voltage wiring
			Blower operating with incorrect airflow	Wrong unit size selection
				Wrong unit family selection
				Wrong motor size Incorrect blower selection
Low Air Coil Pressure Fault (Whole House Dehumidification) Code 11		X	Reduced or no air flow in cooling or Whole House Dehumidification	Check for dirty air filter and clean or replace Check fan motor operation and airflow restrictions Too high of external static - check static vs blower table
			Air temperature out of range	Too much cold vent air - bring entering air temp within design parameters
			Bad pressure switch	Check switch continuity and operation - replace
Low Air Coil Temperature Fault - (Whole House Dehumidification) Code 12		X	Reduced airflow in cooling, Whole House Dehumidification, or constant fan	Check for dirty air filter and clean or replace Check fan motor operation and airflow restrictions Too high of external static - check static vs blower table
			Air temperature out of range	Too much cold vent air - bring entering air temp within design parameters
			Bad thermistor	Check temp and impedance correlation per chart
IFC Fault Code 13 Internal Flow Controller Fault	X	X	No pump output signal	Check DC voltage between A02 and GND - should be between 0.5 and 10 VDC with pump active
			Low pump voltage	Check line voltage to the pump
			No pump feedback signal	Check DC voltage between T1 and GND. Voltage should be between 3 and 4 VDC with pump OFF, and between 0 and 2 VDC with the pump ON
			Bad pump RPM sensor	Replace pump if the line voltage and control signals are present at the pump, and the pump does not operate
ESD - ERV Fault (DXM Only) Green Status LED Code 3	X	X	ERV unit has fault (Rooftop units only)	Troubleshoot ERV unit fault
No Fault Code Shown	X	X	No compressor operation	See 'Only Fan Operates'
	X	X	Compressor overload	Check and replace if necessary
	X	X	Control board	Reset power and check operation
Unit Short Cycles	X	X	Dirty air filter	Check and clean air filter
	X	X	Unit in 'Test Mode'	Reset power or wait 20 minutes for auto exit
	X	X	Unit selection	Unit may be oversized for space - check sizing for actual load of space
	X	X	Compressor overload	Check and replace if necessary
Only Fan Runs	X	X	Thermostat position	Insure thermostat set for heating or cooling operation
	X	X	Unit locked out	Check for lockout codes - reset power
	X	X	Compressor overload	Check compressor overload - replace if necessary
	X	X	Thermostat wiring	Check thermostat wiring at DXM2 - put in Test Mode and jumper Y1 and R to give call for compressor

Performance Troubleshooting

Symptom	Htg	Clg	Possible Cause	Solution
Insufficient Capacity/ Not Cooling or Heating Properly	X	X	Dirty filter	Replace or clean
	X		Reduced or no air flow in heating	Check for dirty air filter and clean or replace
				Check fan motor operation and airflow restrictions
				Too high of external static - check static vs blower table
		X	Reduced or no air flow in cooling	Check for dirty air filter and clean or replace
				Check fan motor operation and airflow restrictions
				Too high of external static - check static vs blower table
	X	X	Leaky duct work	Check supply and return air temperatures at the unit and at distant duct registers if significantly different, duct leaks are present
	X	X	Low refrigerant charge	Check superheat and subcooling per chart
	X	X	Restricted metering device	Check superheat and subcooling per chart - replace
		X	Defective reversing valve	Perform RV touch test
X	X	Thermostat improperly located	Check location and for air drafts behind stat	
X	X	Unit undersized	Recheck loads & sizing check sensible clg load and heat pump capacity	
X	X	Scaling in water heat exchanger	Perform Scaling check and clean if necessary	
X	X	Inlet water too hot or cold	Check load, loop sizing, loop backfill, ground moisture	
High Head Pressure	X		Reduced or no air flow in heating	Check for dirty air filter and clean or replace
				Check fan motor operation and airflow restrictions
				Too high of external static - check static vs blower table
		X	Reduced or no water flow in cooling	Check pump operation or valve operation/setting
				Check water flow adjust to proper flow rate
		X	Inlet water too hot	Check load, loop sizing, loop backfill, ground moisture
	X		Air temperature out of range in heating	Bring return air temp within design parameters
		X	Scaling in water heat exchanger	Perform Scaling check and clean if necessary
X	X	Unit over charged	Check superheat and subcooling - reweigh in charge	
X	X	Non-condensables in system	Vacuum system and reweigh in charge	
X	X	Restricted metering device	Check superheat and subcooling per chart - replace	
Low Suction Pressure	X		Reduced water flow in heating	Check pump operation or water valve operation/setting
				Plugged strainer or filter - clean or replace
				Check water flow adjust to proper flow rate
	X		Water temperature out of range	Bring water temp within design parameters
		X	Reduced air flow in cooling	Check for dirty air filter and clean or replace
Check fan motor operation and airflow restrictions				
	X	Air temperature out of range	Too high of external static - check static vs blower table	
X	X	Insufficient charge	Too much cold vent air - bring entering air temp within design parameters	
	X	Insufficient charge	Check for refrigerant leaks	

Performance Troubleshooting (cont.)

Symptom	Htg	Clg	Possible Cause	Solution
Low Discharge Air Temperature in Heating	X		Too high of air flow	Check fan motor speed selection and airflow chart
	X		Poor performance	See "Insufficient Capacity"
High Humidity		X	Too high of air flow	Check fan motor speed selection and airflow chart
		X	Unit oversized	Recheck loads and sizing check sensible clg load and heat pump capacity
Only Compressor Runs	X	X	Thermostat wiring	Check G wiring at heat pump. Jumper G and R for fan operation.
	X	X	Fan motor relay	Jumper G and R for fan operation. Check for Line voltage across blower relay contacts. Check fan power enable relay operation (if present)
	X	X	Fan motor	Check for line voltage at motor. Check capacitor
	X	X	Thermostat wiring	Check thermostat wiring at or DXM2. Put in Test Mode and then jumper Y1 and W1 to R to give call for fan, compressor and electric heat.
Unit Doesn't Operate in Cooling		X	Reversing Valve	Set for cooling demand and check 24VAC on RV coil. If RV is stuck, run high pressure up by reducing water flow and while operating engage and disengage RV coil voltage to push valve.
		X	Thermostat setup	For DXM2 check for "O" RV setup not "B".
		X	Thermostat wiring	Check O wiring at heat pump. DXM2 requires call for compressor to get RV coil "Click."
Modulating Valve Troubleshooting	X	X	Improper output setting	Verify the AO-2 jumper is in the 0-10V position
			No valve output signal	Check DC voltage between AO2 and GND. Should be 0 when valve is off and between 3.3v and 10v when valve is on.
			No valve operation	Check voltage to the valve Replace valve if voltage and control signals are present at the valve and it does not operate

Troubleshooting Form

Customer: _____ Loop Type: _____ Startup Date: _____
 Model #: _____ Serial #: _____ Antifreeze Type & %: _____
 Complaint: _____

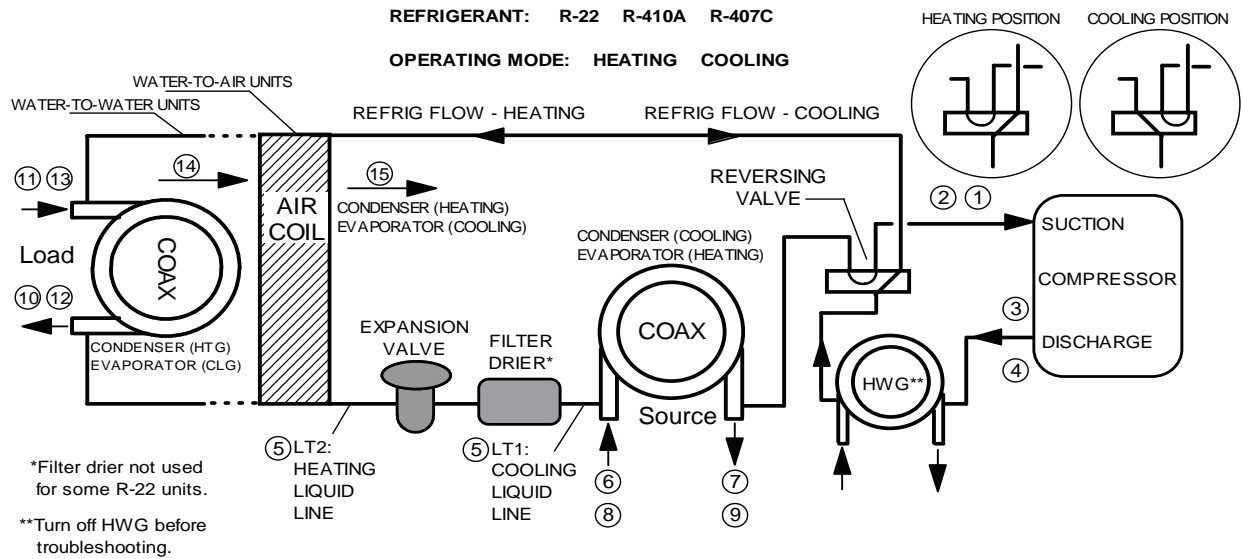

Description	Heating	Cooling	Notes
Voltage			
Compress Amps			
1 Suction Temp			
2 Suction Press			
2a Saturation Temp			
2b Superheat			
3 Discharge Temp			
4 Discharge Press			
4a Saturation Temp			
4b Subcooling			
5 Liquid Line Temp			
6 Source Water In Temp			
7 Source Water Out Temp			Temp Diff. =
8 Source Water In Pres			
9 Source Water Out Pres			
9a Press Drop			
9b GPM			
10 Load Water In Temp			<--Water-to-Water units only
11 Load Water Out Temp			Temp Diff. =
12 Load Water In Pres			<--Water-to-Water units only
13 Load Water Out Pres			<--Water-to-Water units only
13a Press Drop			<--Water-to-Water units only
13b GPM			<--Water-to-Water units only
14 Return Air Temp			<--Water-to-Air units only
15 Supply Air Temp			Temp Diff. =

Heat of Extraction (Absorption) or Heat of Rejection:

HE or HR (Btuh) = _____ Enter HE or HR: _____

Fluid Factor:
 500 (Water); 485 (Antifreeze)

_____ Flow Rate (GPM) x _____ Temp. Diff. (deg F) x _____ Fluid Factor

Note: Never connect refrigerant gauges during startup procedures. Conduct water-side analysis using P/T ports to determine water flow and temperature difference. If water-side analysis shows poor performance, refrigerant troubleshooting may be required. Connect refrigerant gauges as a last resort.

CARRIER CORPORATION
LIMITED EXPRESS WARRANTY/LIMITATION OF REMEDIES AND LIABILITY FOR RESIDENTIAL
GEOTHERMAL PRODUCTS WITH LABOR ALLOWANCE



It is expressly understood that unless a statement is specifically identified as a warranty, statements made by Carrier Corporation, a Delaware corporation, ("Carrier") or its representatives, relating to Carrier's products, whether oral, written or contained in any sales literature, catalog or agreement, are not express warranties and do not form a part of the basis of the bargain, but are merely Carrier's opinion or commendation of Carrier's products. **EXCEPT AS SPECIFICALLY SET FORTH HEREIN, THERE IS NO EXPRESS WARRANTY AS TO ANY OF CARRIER'S PRODUCTS. CARRIER MAKES NO WARRANTY AGAINST LATENT DEFECTS. CARRIER MAKES NO WARRANTY OF MERCHANTABILITY OF THE GOODS OR OF THE FITNESS OF THE GOODS FOR ANY PARTICULAR PURPOSE.**

GRANT OF LIMITED EXPRESS WARRANTY

Carrier warrants its residential geothermal products, purchased and retained in the United States, of America and Canada, to be free from defects in material and workmanship under normal use and maintenance as follows: (1) Residential geothermal air conditioning, heating and/or heat pumps with model numbers beginning with 307 that are built or sold by Carrier ("Carrier Geothermal Units") for ten (10) years from the Warranty Inception Date (as defined below); (2) Auxiliary electric heaters and geothermal pumping modules built or sold by Carrier, with model numbers beginning with 307, for ten (10) years from the Warranty Inception Date; (3) Carrier Geothermal Units (which include the compressor, refrigerant to assist the compressor, refrigerant to assist the condenser, refrigerant to assist the evaporator, reversing valve body and refrigerant metering device) for (10) years from the Warranty Inception Date; (4) Other components and parts built or sold by Carrier, when installed with Carrier Geothermal Units, for one (1) year from the date of shipment from Carrier. The "Warranty Inception Date" shall be the date of original unit installation, or six (6) months from date of unit shipment from Carrier, whichever comes first.

To make a claim under this warranty, parts must be returned to Carrier in Oklahoma City, Oklahoma, freight prepaid, no later than ninety (90) days after the date of the failure of the part; if Carrier determines the part to be defective and within Carrier's Limited Express Warranty, Carrier shall, when such part has been either replaced or repaired, return such to a factory recognized distributor, dealer or service organization, F.O.B. Carrier, Oklahoma City, Oklahoma, freight prepaid. The warranty on any part repaired or replaced under warranty expires at the end of the original warranty period.

This Limited Express Warranty shall cover the labor incurred by Carrier authorized service personnel in connection with the installation of a new or repaired warranty part that is covered by this Limited Express Warranty only to the extent specifically set forth in the then existing labor allowance schedule provided by Carrier's Warranty Department and only as follows: (1) Carrier Geothermal Units for two (2) years from the Warranty Inception Date; (2) Auxiliary electric heaters and geothermal pumping modules built or sold by Carrier, when installed with Carrier Geothermal Units, for two (2) years from the Warranty Inception Date; and (3) Sealed refrigerant circuit components of Carrier Geothermal Units (which components only include the compressor, refrigerant to assist the condenser, refrigerant to assist the evaporator, reversing valve body and refrigerant metering device) for five (5) years from the Warranty Inception Date. Actual Labor costs are not covered by this Limited Express Warranty to the extent they exceed the amount allowed under said allowance schedule. They are not specifically provided for in said allowance schedule, they are not the result of work performed by Carrier authorized service personnel, they are incurred in connection with a part not covered by this Limited Express Warranty, or they are incurred more than the time periods set forth in this paragraph after the Warranty Inception Date.

This warranty does not cover or apply to: (1) Air filters, fuses, refrigerant, fluids, oil; (2) Products relocated after initial installation; (3) Any portion or component of any system that is not supplied by Carrier, regardless of the cause of the failure of such portion or component; (4) Products on which the unit identification tag or labels have been removed or defaced; (5) Products on which payment to Carrier, or to the owner's, seller, or installing contractor, is in default; (6) Products subjected to improper or inadequate installation, maintenance, repair, wiring or voltage conditions; (7) Products subjected to accident, misuse, negligence, abuse, fire, flood, lightning, unauthorized alteration, misapplication, contamination or corrosive air or liquid, operation at abnormal air or liquid temperatures or flow rates, or opening of the refrigerant circuit by unqualified personnel; (8) Mold, fungus or bacteria damages; (9) Corrosion or abrasion of the product; (10) Products supplied by others; (11) Products which have been operated in a manner contrary to Carrier's printed instructions; (12) Products which have insufficient performance as a result of improper system design or improper application, installation, or use of Carrier's products; or (13) Electricity or fuel costs, or any increases or unrealized savings in same, for any reason whatsoever.

This Limited Express Warranty provides the limited labor allowance coverage set forth above. Otherwise, Carrier is not responsible for: (1) The costs of any fluids, refrigerant or system components supplied by others, or associated labor to repair or replace the same, which is incurred as a result of a defective part covered by Carrier's Limited Express Warranty; (2) The costs of labor, refrigerant, materials or service incurred in diagnosis and removal of the defective part, or in obtaining and replacing the new or repaired part; (3) Transportation costs of the defective part from the installation site to Carrier, or of the return of that part if not covered by Carrier's Limited Express Warranty; or (4) The costs of normal maintenance.

This Limited Express Warranty applies to Carrier residential geothermal products ordered from Carrier on or after July 1, 2010 (This would generally include Carrier Geothermal Units with serial numbers beginning with "2710V" and later), and is not retroactive to any products ordered from Carrier prior to July 1, 2010 (this would generally include Carrier Geothermal Units with serial numbers beginning with "2610V" and earlier). If you are unsure if this Limited Express Warranty applies to the product you have purchased, contact Carrier at the phone number or address below.

Limitation: This Limited Express Warranty is given in lieu of all other warranties. If, notwithstanding the disclaimers contained herein, it is determined that other warranties exist, any such express warranty, including without limitation any express warranties or any implied warranties of fitness for particular purpose and merchantability, shall be limited to the duration of the Limited Express Warranty.

LIMITATION OF REMEDIES

In the event of a breach of the Limited Express Warranty, Carrier will only be obligated at Carrier's option to repair the failed part or unit, or to furnish a new or rebuilt part or unit in exchange for the part or unit which has failed. If after written notice to Carrier's factory in Oklahoma City, Oklahoma of each defect, malfunction or other failure, and a reasonable number of attempts by Carrier to correct the defect, malfunction or other failure, and the remedy fails, of its essential purpose, Carrier shall refund the purchase price paid to Carrier in exchange for the return of the sold good(s). Said refund shall be the maximum liability of Carrier. **THIS REMEDY IS THE SOLE AND EXCLUSIVE REMEDY OF THE BUYER OR PURCHASER AGAINST CARRIER FOR BREACH OF CONTRACT, FOR THE BREACH OF ANY WARRANTY OR FOR CARRIER'S NEGLIGENCE OR IN STRICT LIABILITY.**

LIMITATION OF LIABILITY

Carrier shall have no liability for any damages if Carrier's performance is delayed for any reason or is prevented to any extent by any event such as, but not limited to: any war, civil unrest, government restrictions or restraints, strikes, or work stoppages, fire, flood, accident, shortages of transportation, fuel, material, or labor, acts of God or any other reason beyond the sole control of Carrier. **CARRIER EXPRESSLY DISCLAIMS AND EXCLUDES ANY LIABILITY FOR CONSEQUENTIAL OR INCIDENTAL DAMAGE IN CONTRACT, FOR BREACH OF ANY EXPRESS OR IMPLIED WARRANTY, OR IN TORT, WHETHER FOR CARRIER'S NEGLIGENCE OR AS STRICT LIABILITY.**

OBTAINING WARRANTY PERFORMANCE

Normally, the dealer or service organization who installed the products will provide warranty performance for the owner. Should the installer be unavailable, contact any Carrier recognized distributor, dealer or service organization. If assistance is required in obtaining warranty performance, write or call:

Customer Service • 7300 SW 44th Street • Oklahoma City, Oklahoma 73179 • (405) 745-2920

NOTE: Some states or Canadian provinces do not allow limitations on how long an implied warranty lasts, or the limitation or exclusions of consequential or incidental damages, so the foregoing exclusions and limitations may not apply to you. This warranty gives you specific legal rights, and you may also have other rights which vary from state to state and from Canadian province to Canadian province.

Please refer to the Carrier Installation, Operation and Maintenance Manual for operating and maintenance instructions.

Rev.: 6/10
Part No.: CA234

Revision History

Date	Page #	Description
1 Oct., 12	All	First Published



97B0046N05

7300 S.W. 44th Street
Oklahoma City, OK 73179
Phone: 405-745-6000
Fax: 405-745-6058

The Manufacturer works continually to improve its products. As a result, the design and specifications of each product at the time for order may be changed without notice and may not be as described herein. Please contact the Manufacturer's Customer Service Department at 1-405-745-6000 for specific information on the current design and specifications. Statements and other information contained herein are not express warranties and do not form the basis of any bargain between the parties, but are merely Manufacturer's opinion or commendation of its products.

The management system governing the manufacture of Manufacturer's products is ISO 9001:2008 certified.