

Split Products



GT-PX Split (50YDS) Series
 GT-G Split (50YCS) Series
 GT-S Split (38WQS) Series

Indoor and Outdoor Split
 Geothermal Heat Pumps

Installation, Operation &
 Maintenance Instructions
 97B0048N01
 Revision: 28 June, 2007D

Table of Contents

Model Nomenclature	2	Power Wiring	30
Safety	3	Electrical - Low Voltage Wiring	31-32
Storage	4	Low Water Temperature Cutout Selection	31
Pre-Installation	4	Water Valve Wiring	32
Physical Data	5	Thermostat Wiring	33
Unit Dimensions	6-7	Electrical Wiring Schematics	34-36
Equipment Selection	8-10	CXM Controls	37-40
Air Coil Match-ups	8-9	CXM Safety Control Reset	38
Air Handler Selection	10	Unit Start-Up and Operating Conditions	41-42
Water Connections	12-13	Unit and System Checkout Procedure	42
Ground Loop Applications	13-15	Unit Start-Up Procedure	42-43
Open Loop - Ground Water Systems	16-17	Coax Pressure Drop Table	44
Water Quality Standards	18	Operating Pressures	45-46
Refrigeration Installation	19-24	Preventive Maintenance	47
Lineset Information	19	Troubleshooting	48-49
Internal Hot Water Generator	25-26	Functional & Performance Troubleshooting	50-51
Hot Water Generator Module	27-28	Refrigerant Circuit Diagram	52
Electrical - Line Voltage	29	Warranty	53

MODEL NOMENCLATURE: GENERAL OVERVIEW FOR INDOOR SPLIT SERIES

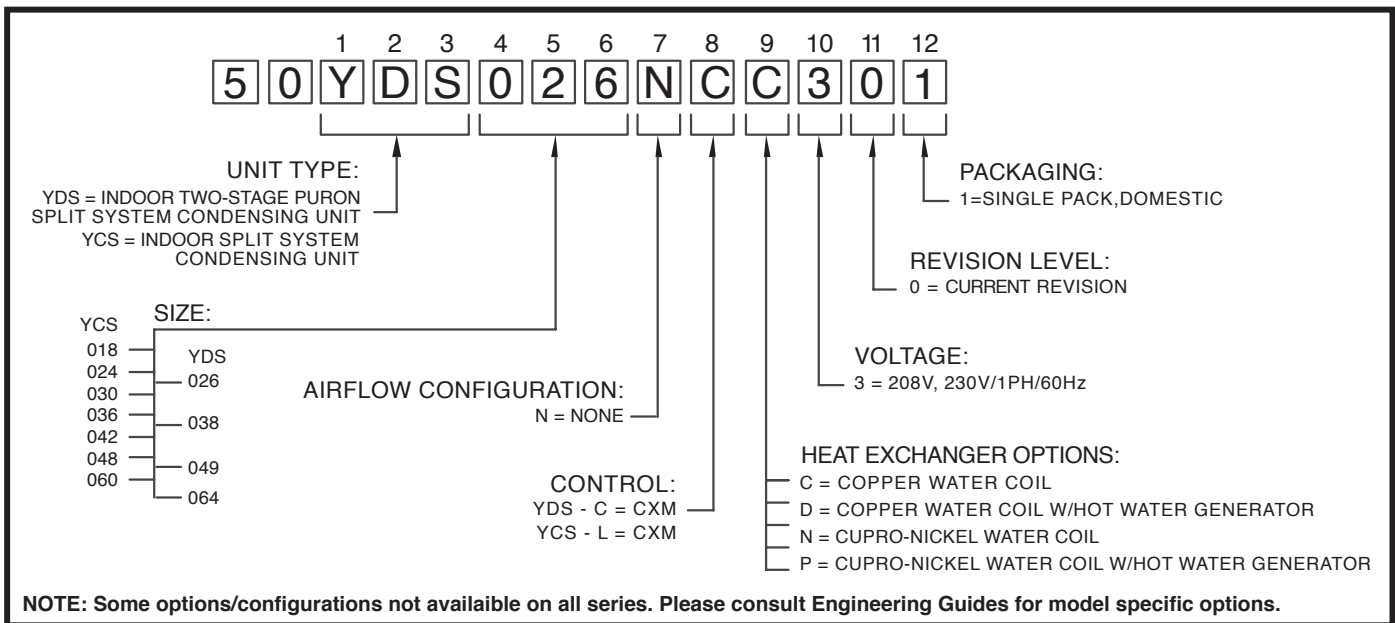

Rev.: 08/15/05D

NOTE: Above model nomenclature is a general reference. Consult individual specification catalogs for detailed information.

MODEL NOMENCLATURE: FOR OUTDOOR SPLIT SERIES

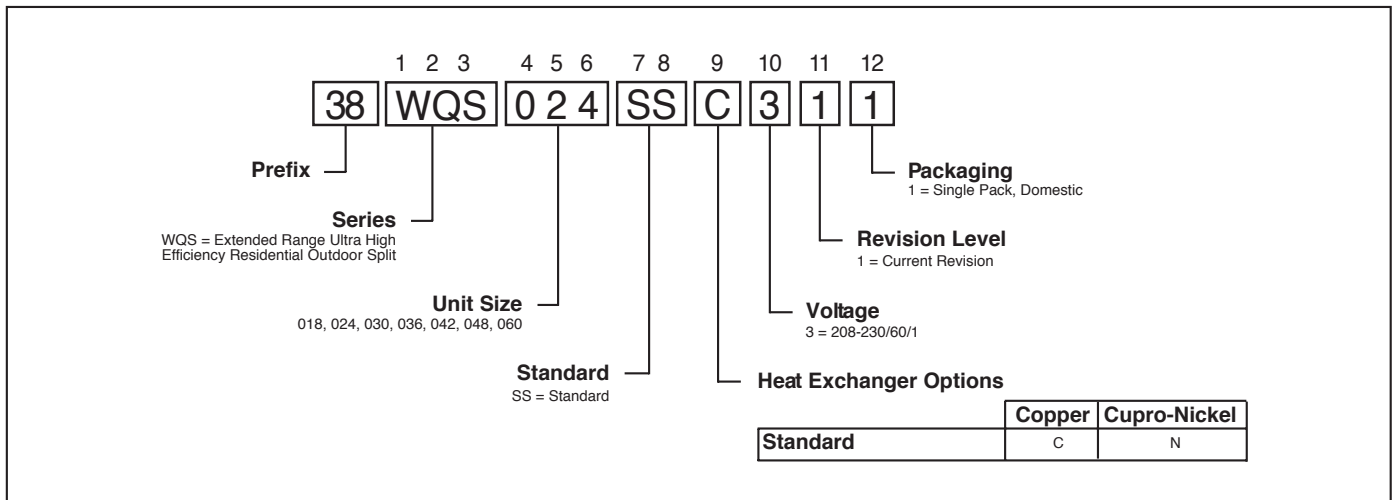

SAFETY

Safety

Warnings, cautions and notices appear throughout this manual. Read these items carefully before attempting any installation, service or troubleshooting of the equipment.

DANGER: Indicates an immediate hazardous situation, which if not avoided will result in death or serious injury. DANGER labels on unit access panels must be observed.

WARNING: Indicates a potentially hazardous situation, which if not avoided could result in death or serious injury.

CAUTION: Indicates a potentially hazardous situation or an unsafe practice, which if not avoided could result in minor or moderate injury or product or property damage.

NOTICE: Notification of installation, operation or maintenance information, which is important, but which is not hazard-related.

⚠ WARNING! ⚠

WARNING! Verify refrigerant type before proceeding. Units are shipped with Puron® (R410A), R22 and R407c refrigerants. The unit label will indicate which refrigerant is provided. The Puron® Application Guideline and Service Manual should be read and understood before attempting to service refrigerant circuits with Puron® refrigerant.

⚠ WARNING! ⚠

WARNING! To avoid the release of refrigerant into the atmosphere, the refrigerant circuit of this unit must be serviced only by technicians who meet local, state, and federal proficiency requirements.

⚠ WARNING! ⚠

WARNING! All refrigerant discharged from this unit must be recovered **WITHOUT EXCEPTION**. Technicians must follow industry accepted guidelines and all local, state, and federal statutes for the recovery and disposal of refrigerants. If a compressor is removed from this unit, refrigerant circuit oil will remain in the compressor. To avoid leakage of compressor oil, refrigerant lines of the compressor must be sealed after it is removed.

⚠ CAUTION! ⚠

CAUTION! To avoid equipment damage, **DO NOT** use these units as a source of heating or cooling during the construction process. The mechanical components and filters will quickly become clogged with construction dirt and debris, which may cause system damage.

GENERAL INFORMATION

Inspection

Upon receipt of the equipment, carefully check the shipment against the bill of lading. Make sure all units have been received. Inspect the packaging of each unit, and inspect each unit for damage. Insure that the carrier makes proper notation of any shortages or damage on all copies of the freight bill and completes a common carrier inspection report. Concealed damage not discovered during unloading must be reported to the carrier within 15 days of receipt of shipment. If not filed within 15 days, the freight company can deny the claim without recourse. Note: It is the responsibility of the purchaser to file all necessary claims with the carrier. Notify your equipment supplier of all damage within fifteen (15) days of shipment.

Storage

Equipment should be stored in its original packaging in a clean, dry area. Store units in an upright position at all times. Stack units a maximum of 3 units high.

Unit Protection

Cover units on the job site with either the original packaging or an equivalent protective covering. Cap the open ends of pipes stored on the job site. In areas where painting, plastering, and/or spraying has not been completed, all due precautions must be taken to avoid physical damage to the units and contamination by foreign material. Physical damage and contamination may prevent proper start-up and may result in costly equipment clean-up.

Examine all pipes, fittings, and valves before installing any of the system components. Remove any dirt or debris found in or on these components.

Pre-Installation

Installation, Operation, and Maintenance instructions are provided with each unit. Horizontal equipment is designed for installation above false ceiling or in a ceiling plenum. Other unit configurations are typically installed in a mechanical room. The installation site chosen should include adequate service clearance around the unit. Before unit start-up, read all manuals and become familiar with the unit and its operation. Thoroughly check the system before operation.

Prepare units for installation as follows:

1. Compare the electrical data on the unit nameplate with ordering and shipping information to verify that the correct unit has been shipped.
2. Keep the cabinet covered with the original packaging until installation is complete and all plastering, painting, etc. is finished.
3. Verify refrigerant tubing is free of kinks or dents and that it does not touch other unit components.
4. Inspect all electrical connections. Connections must be clean and tight at the terminals.
5. Loosen compressor bolts on units equipped with compressor spring vibration isolation until the

compressor rides freely on the springs. Remove shipping restraints.

6. REMOVE COMPRESSOR SUPPORT PLATE 1/4" SHIPPING BOLTS (2 on each side) TO MAXIMIZE VIBRATION AND SOUND ATTENUATION (R22 indoor units only).
7. Locate and verify any hot water generator (HWG) or other accessory kit located in the compressor section.

⚠ CAUTION! ⚠

CAUTION! DO NOT store or install units in corrosive environments or in locations subject to temperature or humidity extremes (e.g., attics, garages, rooftops, etc.). Corrosive conditions and high temperature or humidity can significantly reduce performance, reliability, and service life. Always move and store units in an upright position. Tilting units on their sides may cause equipment damage.

NOTICE! Failure to remove shipping brackets from spring-mounted compressors will cause excessive noise, and could cause component failure due to added vibration.

⚠ CAUTION! ⚠

CAUTION! CUT HAZARD - Failure to follow this caution may result in personal injury. Sheet metal parts may have sharp edges or burrs. Use care and wear appropriate protective clothing, safety glasses and gloves when handling parts and servicing heat pumps.

UNIT PHYSICAL DATA

GT-PX Two-Stage Split (50YDS) Series

Model	026	038	049	064
Compressor [1 Each]	Copeland UltraTech Two-Stage Scroll			
Factory Charge R410A (oz) [kg]	90 [2.55]	104 [2.95]	126 [3.57]	168 [4.76]
Water Connection Size				
IPT (in)	1	1	1	1
HWG Connection Size				
IPT (in)	1	1	1	1
Line Set Connection Size				
Suction Line Sweat Connection (in.)	3/4	7/8	7/8	1-1/8
Liquid Line Sweat Connection (in.)	3/8	3/8	3/8	1/2
Weight - Operating, (lbs) [kg]	203 [92]	221 [100]	250 [113]	265 [120]
Weight - Packaged, (lbs) [kg]	218 [99]	236 [107]	265 [120]	280 [127]

All units have spring compressor mountings, TXV expansion devices, and 1/2" [12.2mm] & 3/4" [19.1mm] electrical knockouts.

GT-G Split (50YCS) Series

Model	018	024	030	036	042	048	060
Compressor [1 Each]	Scroll						
Factory Charge R22 (oz) [kg]	90 [2.55]	104 [2.95]	108 [3.06]	117 [3.32]	122 [3.46]	130 [3.69]	136 [3.86]
Water Connection Size							
IPT (in)	1	1	1	1	1	1	1
HWG Connection Size							
IPT (in)	1	1	1	1	1	1	1
Line Set Connection Size							
Suction Line Sweat Connection (in.)	3/4	7/8	7/8	7/8	7/8	7/8	1-1/8
Liquid Line Sweat Connection (in.)	3/8	3/8	3/8	3/8	3/8	3/8	1/2
Weight - Operating, (lbs) [kg]	165 [75]	203 [92]	205 [93]	217 [98]	221 [100]	229 [104]	235 [107]
Weight - Packaged, (lbs) [kg]	180 [82]	218 [99]	220 [100]	232 [105]	236 [107]	244 [111]	250 [113]

All units have spring compressor mountings, TXV expansion devices, and 1/2" [12.2mm] & 3/4" [19.1mm] electrical knockouts.

GT-S Split (38WQS) Series

Model	018	024	030	036	042	048	060
Compressor [1 Each]	Rotary	Scroll					
Factory Charge R22 (oz) [kg]	70 [1.98]	74 [2.10]	86 [2.52]	101 [2.86]	122 [3.46]	130 [3.69]	136 [3.86]
Water Connection Size							
EPT (in)	1-1/4						
Line Set Connection Size							
Suction Line Sweat Connection (in.)	3/4	3/4	7/8	7/8	7/8	7/8	1-1/8
Liquid Line Sweat Connection (in.)	3/8	3/8	3/8	3/8	3/8	3/8	1/2
Weight - Operating, (lbs) [kg]	165 [75]	203 [92]	205 [93]	217 [98]	221 [100]	229 [104]	235 [107]
Weight - Packaged, (lbs) [kg]	180 [82]	218 [99]	220 [100]	232 [105]	236 [107]	244 [111]	250 [113]

All units have spring compressor mountings, TXV expansion devices, weather resistant cabinet, and 1/2" [12.2mm] & 3/4" [19.1mm] electrical knockouts. Hot Water Generator with factory installed hot gas service ports.

DIMENSIONS — GT-PX SPLIT (50YDS) SERIES

GT-PX Two-Stage Split (50YDS) Series

Model	Overall Cabinet			Water Connections							Refrigerant Connection				Electrical Knockouts				
	A Width	B Height	C Depth	1 Water In/Out	2 HWG In/Out	D1 Water In	D2 Water In	E Water Out	F HWG In	G HWG Out	3 Suction	4 Liquid	H	I	J	K	L	M	
				Swivel															
026	in	22.4	19.3	25.6	1	1	1.6	2.1	11.0	13.9	16.9	3/4	3/8	7.3	5.1	3.6	6.1	8.6	1.4
	cm	56.9	49.0	65.0	-	-	4.1	5.3	27.9	35.3	42.9	-	-	18.5	13.0	9.1	15.5	21.8	3.6
038	in	25.4	21.3	30.6	1	1	1.7	3.4	12.1	15.6	18.9	7/8	3/8	8.4	6.1	3.6	6.1	8.6	1.7
	cm	64.5	54.1	77.7	-	-	4.3	8.6	30.7	39.6	48.0	-	-	21.3	15.5	9.1	15.5	21.8	4.3
049	in	25.4	21.3	30.6	1	1	1.7	3.4	12.1	15.6	18.9	7/8	3/8	8.4	6.1	3.6	6.1	8.6	1.7
	cm	64.5	54.1	77.7	-	-	4.3	8.6	30.7	39.6	48.0	-	-	21.3	15.5	9.1	15.5	21.8	4.3
064	in	25.4	21.3	30.6	1	1	1.7	3.4	12.1	15.6	18.9	1-1/8	1/2	8.4	6.1	3.6	6.1	8.6	1.7
	cm	64.5	54.1	77.7	-	-	4.3	8.6	30.7	39.6	48.0	-	-	21.3	15.5	9.1	15.5	21.8	4.3

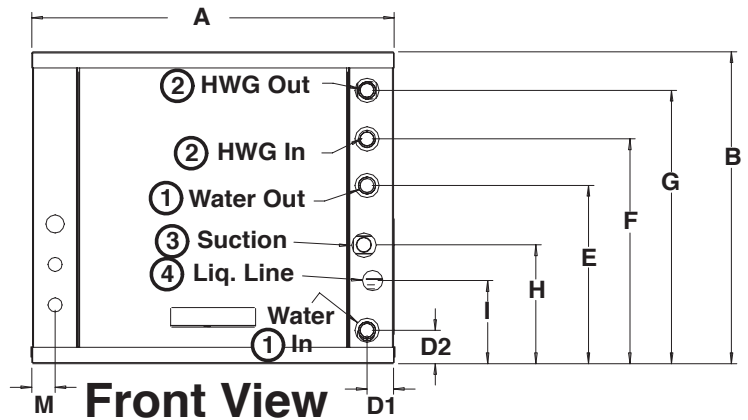
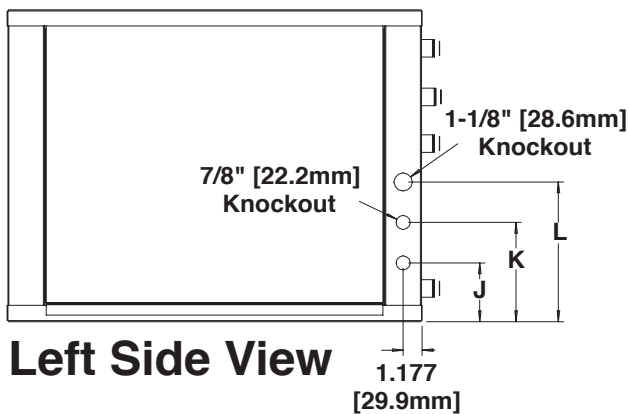
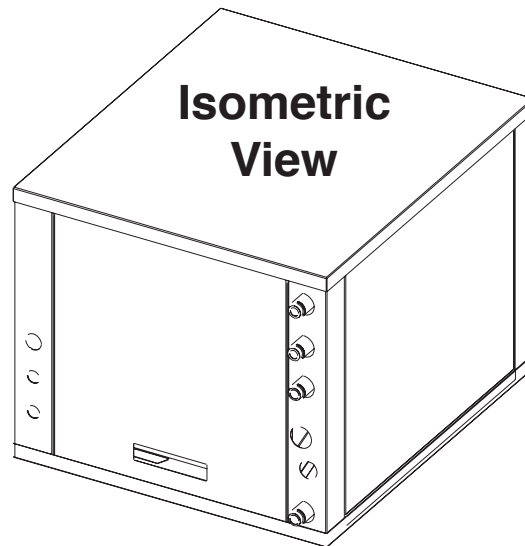
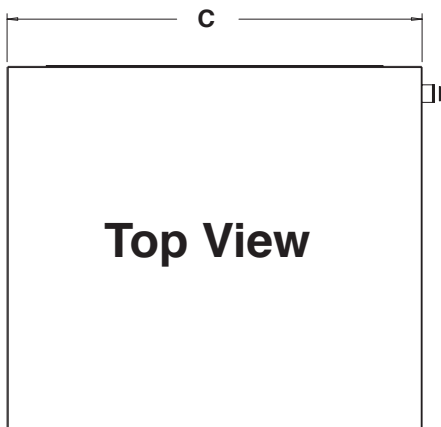

DIMENSIONS — GT-G SPLIT (50YCS) & GT-S SPLIT (38WQS) SERIES

GT-G Split (50YCS) Series

Model	Overall Cabinet			Water Connections						Refrigerant Connections				Electrical Knockouts				
	A	B	C	1 - Water In & Out		2 - HWG In & Out		D	E	F	G	3-Size	4-Size	H	I	J	K	L
	Width	Height	Depth	Swivel	Swivel	In	Out	HWG In	HWG Out	Suction	Liquid	Suction	Liquid	J	K	L		
018	in. cm.	22.4 [56.9]	19.3 [49.0]	25.6 [65.0]	1"	1"	2.4 [6.1]	5.4 [13.7]	13.9 [35.3]	16.9 [42.9]	3/4"	3/8"	8.1 [20.6]	11.1 [28.3]	5.7 [14.5]	9.7 [24.6]	12.2 [31.0]	
024	in. cm.	22.4 [56.9]	19.3 [49.0]	25.6 [65.0]	1"	1"	2.4 [6.1]	5.4 [13.7]	13.9 [35.3]	16.9 [42.9]	3/4"	3/8"	8.1 [20.6]	11.1 [28.3]	5.7 [14.5]	9.7 [24.6]	12.2 [31.0]	
030	in. cm.	22.4 [56.9]	19.3 [49.0]	25.6 [65.0]	1"	1"	2.4 [6.1]	5.4 [13.7]	13.9 [35.3]	16.9 [42.9]	7/8"	3/8"	8.1 [20.6]	11.1 [28.3]	5.7 [14.5]	9.7 [24.6]	12.2 [31.0]	
036	in. cm.	22.4 [56.9]	19.3 [49.0]	25.6 [65.0]	1"	1"	2.4 [6.1]	5.4 [13.7]	13.9 [35.3]	16.9 [42.9]	7/8"	3/8"	8.1 [20.6]	11.1 [28.3]	5.7 [14.5]	9.7 [24.6]	12.2 [31.0]	
042	in. cm.	25.4 [64.5]	21.3 [54.1]	30.6 [77.7]	1"	1"	2.4 [6.1]	5.4 [13.7]	15.9 [40.4]	18.9 [48.0]	7/8"	3/8"	9.1 [23.2]	12.1 [30.8]	8.1 [20.6]	11.7 [29.7]	14.2 [36.1]	
048	in. cm.	25.4 [64.5]	21.3 [54.1]	30.6 [77.7]	1"	1"	2.4 [6.1]	5.4 [13.7]	15.9 [40.4]	18.9 [48.0]	7/8"	3/8"	9.1 [23.2]	12.1 [30.8]	8.1 [20.6]	11.7 [29.7]	14.2 [36.1]	
060	in. cm.	25.4 [64.5]	21.3 [54.1]	30.6 [77.7]	1"	1"	2.4 [6.1]	5.4 [13.7]	15.9 [40.4]	18.9 [48.0]	1-1/8"	1/2"	9.1 [23.2]	12.1 [30.8]	8.1 [20.6]	11.7 [29.7]	14.2 [36.1]	

Rev.: 08/10/05D

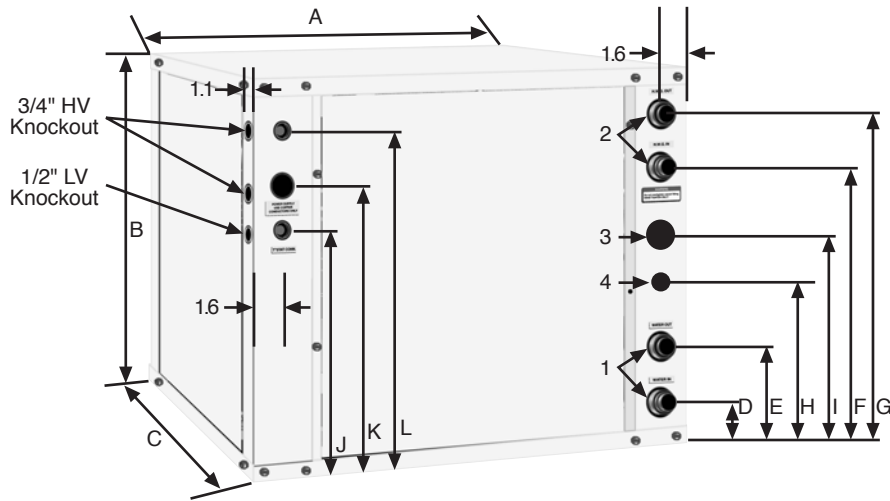

GT-S Split (38WQS) Series

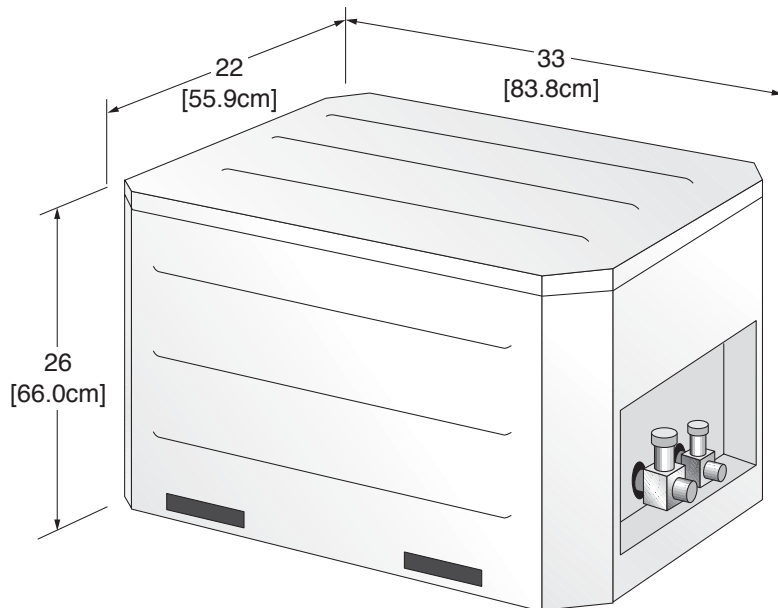

EQUIPMENT SELECTION

The installation of geothermal heat pump units and all associated components, parts, and accessories which make up the installation shall be in accordance with the regulations of ALL authorities having jurisdiction and MUST conform to all applicable codes. It is the responsibility of the installing contractor to determine and comply with ALL applicable codes and regulations.

General

Proper indoor coil selection is critical to system efficiency. Using an older-model coil can affect efficiency and may not provide the customer with rated or advertised EER and COP. Coil design and technology have dramatically improved operating efficiency and capacity in the past 20 years. Homeowners using an older coil are not reaping these cost savings and comfort benefits. NEVER MATCH AN R-22 INDOOR COIL WITH AN R-410A COMPRESSOR SECTION.

Newer indoor coils have a larger surface area, enhanced fin design, and grooved tubing. These features provide a larger area for heat transfer, improving efficiency and expanding capacity. Typical older coils may only have one-third to one-half the face area of these redesigned coils.

Indoor Coil Selection - GT-PX (50YDS) Puron® Geothermal Split System

Geothermal split system heat pumps are rated in the ARI directory with a specific indoor coil match. GT-PX Puron split system (50YDS) models are rated with Carrier/ Bryant FV4 or FE4 series variable speed air handlers as shown in Table 1a. Other combinations (e.g. variable speed furnace with cased coil) may attain the same ARI ratings providing that the specifications meet or exceed those listed in Table 1a AND Table 1b. An ECM motor and TXV is required. Cap tubes and fixed orifices are not acceptable. PSC fans may be used if matched to Table 1b, but will not meet ARI ratings. If using PSC fan, compressor section must be operated as a single stage unit (i.e. wired for either 1st stage or 2nd stage). Without the ability to vary the airflow, supply air temperatures may not be acceptable if the compressor is allowed to change stages when used with a PSC fan motor.

Table 1a: GT-PX (50YDS) Puron® Geothermal Split System Air Handler Matches for ARI Ratings

Compressor Section	026	038	049	064
Air Handler Model FV4 or FE4	003	005	006	006
Refrigerant	R-410A			
Metering Device	TXV (required)			
Air Coil Type Rows - Fins/in. Face Area (sq. ft.)	Slope 3 - 14.5 3.46	A 3 - 14.5 5.93	A 3 - 14.5 7.42	A 3 - 14.5 7.42
Cabinet Configuration	Upflow / Downflow / Horizontal (Multipoise)			
ECM Settings for ARI Ratings (FV4 Fan Coil)	AC/HP size: 036 System Type: Comfort AC/HP CFM Adjust: Nom	AC/HP size: 036 System Type: HP-Effic AC/HP CFM Adjust: High	AC/HP size: 048 System Type: Comfort AC/HP CFM Adjust: High	AC/HP size: 060 System Type: Comfort AC/HP CFM Adjust: High
Fan Motor Type - HP	ECM - 1/2	ECM - 1/2	ECM - 3/4	ECM - 3/4

EQUIPMENT SELECTION

Table 1b: Selection of Coils other than Above Models for Puron® Geothermal Split Systems

Model*	Nominal Tons*	Evaporator Temp (°F)	CFM	Capacity (MBtuh)**	Add-on CK5P Coil with TXV <u>AND</u> Vspd furn.	FX4 PSC Fan Coil (not an ARI rated combination)
026 - Part Load	1.5	50	530	19.2 - 22.4	A/T/W 036	018
026 - Full Load	2.0	52	880	24.2 - 28.2	A/T/W 036	030
038 - Part Load	2.5	51	700	25.2 - 29.2	A/T/W 048	036
038 - Full Load	3.0	50	1200	34.5 - 40.1	A/T 060	036
049 - Part Load	3.5	47	1000	34.3 - 39.9	A/T 060	042
049 - Full Load	4.0	48	1650	46.3 - 53.8	X060	048
064 - Full Load	5.0	48	1850	54.5 - 63.3	2 - A/T/W 036	060

* Nominal tons are at ARI/ISO 13256-1 GLHP conditions. Two-stage units may be operated in single-stage mode if desired, where smaller capacity is required. For example, a model 026 may be used as a 1-1/2 ton unit if “locked” into 1st stage operation only. If PSC fan is used, unit must be “locked” into either 1st or 2nd stage. An ECM fan is required for two-stage operation and for ARI ratings. Size air handler for “Full Load” if operating in two-stage mode.

**When selecting an air handler based upon the above conditions, choose entering WB temperature of 67°F. Use evaporator temperature, CFM and capacity requirements as listed above. The air handler capacity must be at least at the minimum capacity shown in the table in order for the ARI rating condition to be valid. See Figure 1 for an example selection.

Indoor Coil Selection - R-22 Units

Geothermal split system heat pumps with R-22 refrigerant are rated in the ARI directory with a “generic” indoor coil match and PSC fan. Selection of air handlers that attain the published ARI ratings must meet or exceed the specifications listed in Table 2. **A TXV is required.** Cap tubes and fixed orifices are not acceptable.

Table 2: R-22 Air Handler Characteristics

Model*	Nominal Tons*	Evaporator Temp (°F)	CFM	Capacity (MBtuh)**
018	1.5	50	600	18.5 - 21.3
024	2.0	47	800	25.5 - 29.3
030	2.5	49	1000	31.5 - 36.2
036	3.0	48	1200	37.0 - 42.5
042	3.5	45	1400	42.2 - 48.5
048	4.0	46	1600	50.0 - 57.5
060	5.0	45	2000	58.0 - 66.7

* Nominal tons are at ARI/ISO 13256-1 GLHP conditions.

**When selecting an air handler based upon the above conditions, choose entering WB temperature of 67°F. Use evaporator temperature, CFM and capacity requirements as listed above. The air handler capacity must be at least at the minimum capacity shown in the table in order for the ARI rating condition to be valid. See Figure 1 for an example selection.

EQUIPMENT SELECTION

Air Handler Selection Example

Figure 1 shows a typical performance table for a heat pump air handler. Suppose the evaporator temperature required is 50°F, the capacity required is 35,000 Btuh and the airflow required is 1,200 CFM. Each evaporator temperature listed in the table shows three wet bulb temperatures. As recommended in the table notes above, select the 67°F WB column. At 1,200 CFM, the model 003 capacity is 36 MBtuh, which is higher than the minimum capacity required of 35,000 Btuh. In this example, model 003 would be the appropriate match.

Figure 1: Selecting Air Handler

UNIT SIZE	EVAPORATOR AIR Cfm BF	COIL REFRIGERANT TEMPERATURE (°F)														
		35			40			45			50			55		
		Evaporator Air — Entering Wet-Bulb Temperature (°F)														
		72	67	62	72	67	62	72	67	62	72	67	62	72	67	62
003	800	59	48	38	53	42	32	46	35	24	39	27	20	30	18	16
	0.20	28	29	31	25	27	28	22	23	24	19	20	20	16	16	16
	1000	68	56	45	61	49	37	54	41	29	45	32	25	35	22	20
	0.22	32	34	37	29	31	33	26	28	28	23	24	25	19	20	20
	1200	75	62	49	68	54	42	60	45	34	50	36	29	40	25	23
0.25	35	39	42	32	36	38	29	32	33	26	28	29	22	23	23	
005	1400	80	67	54	73	59	46	64	49	38	54	39	32	43	28	27
	0.27	38	43	47	35	39	43	32	36	37	28	32	32	24	26	27
	750	61	49	39	55	43	33	48	37	27	41	29	20	33	21	17
	0.04	27	27	28	24	25	25	21	22	22	18	18	18	15	15	15
	950	74	60	48	67	53	40	59	45	33	50	35	25	39	24	21
0.06	32	34	35	29	30	31	25	26	27	22	23	23	18	18	19	
006	1150	89	72	57	79	63	48	69	52	38	58	41	31	44	29	25
	0.07	37	39	41	33	35	36	29	31	32	25	26	27	20	22	22
	1500	103	84	66	92	73	56	81	61	46	67	48	39	52	34	31
	0.10	43	46	49	38	41	44	34	37	39	29	32	33	25	27	27
	1700	110	89	71	99	78	60	86	65	49	72	51	42	56	37	35
0.11	45	50	53	41	45	48	36	39	42	31	34	36	27	29	30	
006	1050	77	62	50	69	55	43	61	47	35	52	38	27	41	27	22
	0.01	34	36	37	31	32	33	27	28	29	23	25	24	20	20	20
	1300	100	82	65	90	71	55	79	60	45	66	47	37	49	32	27
	0.02	42	45	47	37	40	42	33	35	37	29	31	32	23	25	24
	1750	117	96	77	106	84	65	93	71	53	78	56	46	60	40	34
0.04	48	53	57	44	48	52	39	43	46	34	38	39	29	31	31	
006	2050	126	103	83	114	91	71	99	76	59	84	60	50	65	44	39
	0.05	52	58	63	48	53	57	43	47	51	37	42	43	33	35	35
	2900	132	108	87	119	95	75	105	80	63	88	63	54	70	47	42
0.06	55	62	68	50	57	61	45	51	54	40	45	46	35	39	38	

= Gross cooling capacity (MBtuh)
 = Sensible heat capacity (MBtuh)
 BF = Bypass factor

Utilizing the Existing Air Handler or Coil (R22 units only)

It is recommended that a new coil or air handler be installed with any geothermal split system compressor section due to the low initial cost of the additional equipment versus the reliability and benefit of new technology, increased reliability and warranty. However, if the existing air handler must be used (R22 systems only), the following conditions apply:

- If the existing coil currently uses an orifice, the orifice must be removed and replaced with a TXV. If the coil utilizes capillary tubes, it will not operate properly with the geothermal split system and should be replaced.
- If life expectancy of indoor coil (and associated components - fan, cabinet, etc.) is less than 7-10 years, indoor section should be replaced.

INSTALLATION

NOTICE! Failure to remove shipping brackets from spring-mounted compressors will cause excessive noise, and could cause component failure due to added vibration.

The installation of water source heat pump units and all associated components, parts and accessories which make up the installation shall be in accordance with the regulations of ALL authorities having jurisdiction and MUST conform to all applicable codes. It is the responsibility of the installing contractor to determine and comply with ALL applicable codes and regulations.

Removing Existing Condensing Unit (Where Applicable)

1. Pump down condensing unit. Close the liquid line service valve of existing condensing unit and start compressor to pump refrigerant back into compressor section. Then, close suction service valve while compressor is still running to trap refrigerant in outdoor section. Immediately kill power to the condensing unit.
2. Disconnect power and low voltage and remove old condensing unit. Cut or unbrazed line set from unit. Remove condensing unit.
3. If condensing unit is not operational or will not pump down, refrigerant should be recovered using appropriate equipment.
4. Replace line set, especially if upgrading system from R-22 to R-410A refrigerant. If line set cannot be replaced, it must be thoroughly flushed before installing new compressor section. R-410A compressors use POE oil instead of mineral oil (R-22 systems). Mineral oil is not compatible with POE oil, and could cause system damage if not completely flushed from the line set.

“Indoor” Compressor Section Location

Both “indoor” and “outdoor” versions of the geothermal split system compressor section are available. “Indoor” version is not designed for outdoor installation. Locate the unit in an INDOOR area that allows enough space for service personnel to perform typical maintenance or repairs without removing unit. Units are typically installed in a mechanical room or closet. Never install units in areas subject to freezing or where humidity levels could cause cabinet condensation (such as unconditioned spaces subject to 100% outside air). Consideration should be given to access for easy removal of service access panels. Provide sufficient room to make water, electrical, and line set connections.

Any access panel screws that would be difficult to remove after the unit is installed should be removed prior to setting the unit. Refer to Figure 2 for an illustration of a typical installation. Refer to “Physical Dimensions” section for dimensional data. Conform to the following guidelines when selecting unit location:

1. Install the unit on a piece of rubber, neoprene or other mounting pad material for sound isolation. The pad should be at least 3/8” [10mm] to 1/2” [13mm] in thickness. Extend the pad beyond all four edges of the unit.
2. Provide adequate clearance for maintenance and service. Do not block access panels with piping, conduit or other materials.
3. Provide access for servicing the compressor and coils without removing the unit.
4. Provide an unobstructed path to the unit within the closet or mechanical room. Space should be sufficient to allow removal of the unit, if necessary.
5. In limited side access installations, pre-removal of the control box side mounting screws will allow control box removal for future servicing (R22 units only).
6. Provide access to water valves and fittings and screwdriver access to the unit side panels and all electrical connections.

“Outdoor” Compressor Section Location

Locate the unit in an outdoor area that allows easy loop and lineset access and also has enough space for service personnel to perform typical maintenance or repairs. The “outdoor” compressor section is usually installed on a condenser pad directly outside the lineset access into the building. The service valve side can be located toward the building, keeping the loop access end away from the building. Conform to the following guidelines when selecting unit location:

1. Provide adequate access for loop trench excavation.
2. Locate unit directly outside lineset penetration if possible. Utilize existing condenser pad where possible.
3. Provide access for servicing and maintenance.

“Outdoor” compressor section may be mounted on a vibration isolation pad with loop access hole as shown in Figure 3. When mounting on an existing concrete condenser pad, 3” [76mm] holes should be bored through the pad to accommodate the pipe (1-1/4” - 32mm) and insulation (1/2” [13mm] wall thickness). Figure 3 illustrates location and dimensions of the holes required.

Air Handler Installation

This manual specifically addresses the compressor section of the system. Air handler location and installation should be according to the instructions provided with the air handling unit.

INSTALLATION

Figure 2: 50YDS/YCS Installation

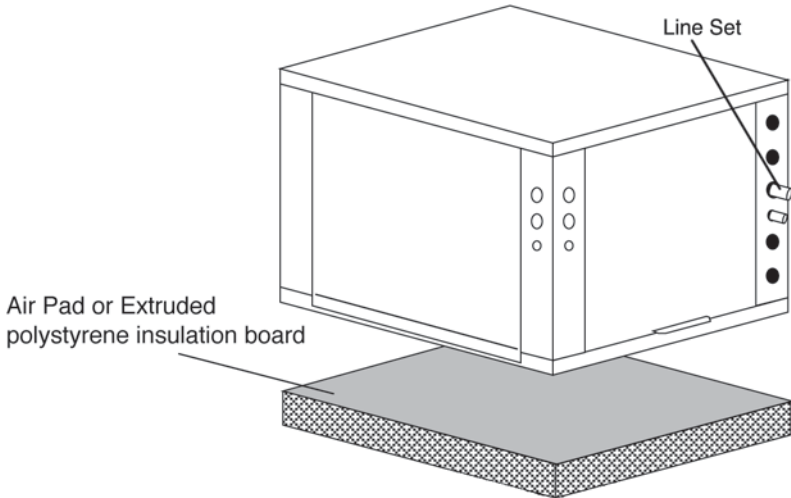
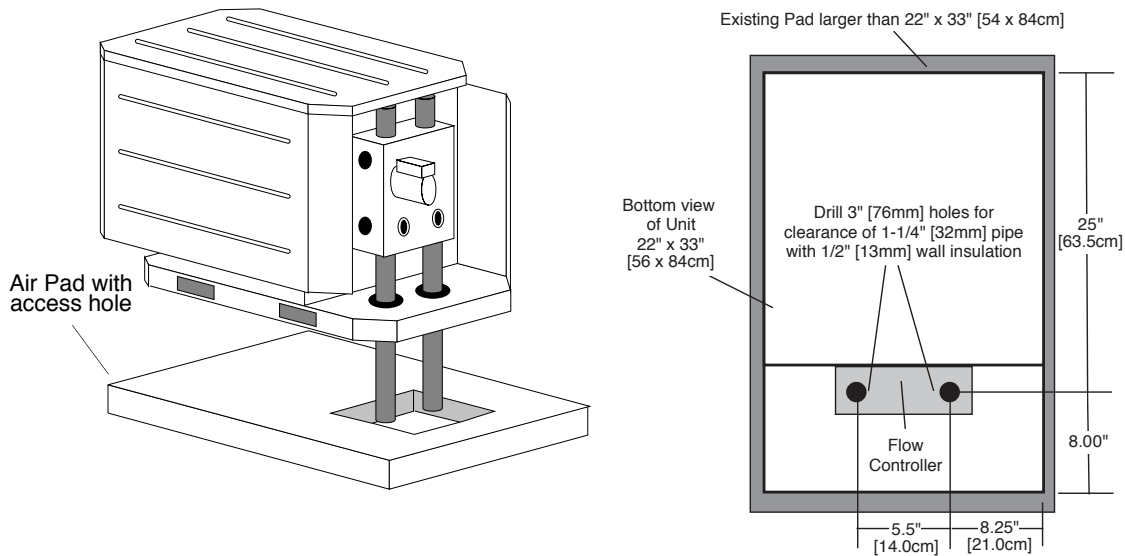

Figure 3: 38WQS Installation



External Flow Controller Mounting

The Flow Controller can be mounted beside the unit as shown in Figure 7. Review the Flow Controller installation manual for more details.

Water Connections-Residential (Distributor) Models

Residential models utilize swivel piping fittings for water connections that are rated for 450 psi (3101 kPa) operating pressure. The connections have a rubber gasket seal similar to a garden hose gasket, which when mated to the flush end of most 1" threaded male pipe fittings provides a leak-free seal without the need for thread sealing tape or joint compound. Insure that the rubber seal is in the swivel connector prior to attempting any connection (rubber seals are shipped attached to the swivel connector). **DO NOT OVER TIGHTEN** or leaks may occur.

The female locking ring is threaded onto the pipe threads which holds the male pipe end against the rubber gasket, and seals the joint. **HAND TIGHTEN ONLY! DO NOT OVERTIGHTEN!**

Figure 4: Water Connections (Indoor Compressor Section)

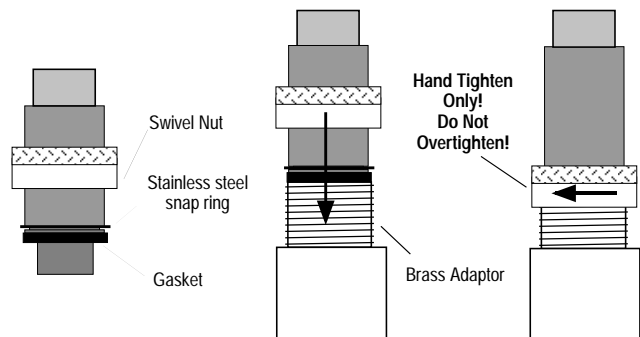

INSTALLATION

Internal Flow Controller Mounting - “Outdoor” Compressor Section Only

The Flow Controller can be mounted in the “outdoor” compressor section directly inside the cabinet as shown in Figure 5. Remove the water legs from the outdoor unit at the union fittings. Attach the AFC4T 1” MPT x o-ring fittings to the removed water legs. Carefully attach the Flow Controller to the loop piping and mount to the outdoor unit using the mounting lugs attached to the unit. Insert the water legs into the Flow Controller using the o-ring fittings. Re-connect the water leg unions.

NOTICE! Opening in the bottom of the unit for loop piping must be sealed to prevent rodents from getting into the cabinet and damaging control wiring. Spray type foam may be used to seal the opening(s).

Figure 6: AFC4T Connector



Figure 5: Water Connections (Outdoor Compressor Section)

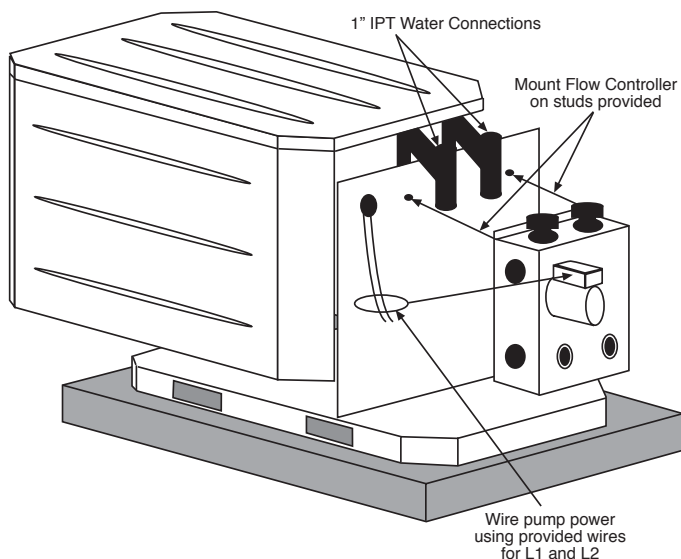

GROUND-LOOP HEAT PUMP APPLICATIONS

⚠ CAUTION! ⚠

CAUTION! The following instructions represent industry accepted installation practices for closed loop earth coupled heat pump systems. Instructions are provided to assist the contractor in installing trouble free ground loops. These instructions are recommendations only. State/provincial and local codes **MUST** be followed and installation **MUST** conform to **ALL** applicable codes. It is the responsibility of the installing contractor to determine and comply with **ALL** applicable codes and regulations.

Pre-Installation

Prior to installation, locate and mark all existing underground utilities, piping, etc. Install loops for new construction before sidewalks, patios, driveways, and other construction has begun. During construction, accurately mark all ground loop piping on the plot plan as an aid in avoiding potential future damage to the installation.

Piping Installation

The typical closed loop ground source system is shown in Figures 7 and 8. All earth loop piping materials should be limited to polyethylene fusion only for in-ground sections of the loop. Galvanized or steel fittings should not be used at any time due to their tendency to corrode. All plastic to metal threaded fittings should be avoided due to their potential to leak in earth coupled applications. A flanged fitting should be substituted. P/T plugs should be used so that flow can be measured using the pressure drop of the unit heat exchanger.

GROUND-LOOP HEAT PUMP APPLICATIONS

Earth loop temperatures can range between 25 and 110°F [-4 to 43°C]. Flow rates between 2.25 and 3 gpm per ton [2.41 to 3.23 l/m per kW] of cooling capacity is recommended in these applications.

Test individual horizontal loop circuits before backfilling. Test vertical U-bends and pond loop assemblies prior to installation. Pressures of at least 100 psi [689 kPa] should be used when testing. Do not exceed the pipe pressure rating. Test entire system when all loops are assembled.

Flushing the Earth Loop

Once piping is completed between the unit, Flow Controller and the ground loop (Figures 7 and 8), the loop is ready for final purging and charging. A flush cart with at least a 1.5 hp [1.1 kW] pump is required to achieve enough fluid velocity in the loop piping system to purge air and dirt particles. An antifreeze solution is used in most areas to prevent freezing. All air and debris must be removed from the earth loop piping before operation. Flush the loop with a high volume of water at a minimum velocity of 2 fps (0.6 m/s) in all piping. The steps below must be followed for proper flushing.

1. Fill loop with water from a garden hose through the flush cart before using the flush cart pump to insure an even fill.
2. Once full, the flushing process can begin. Do not allow the water level in the flush cart tank to drop below the pump inlet line to avoid air being pumped back out to the earth loop.
3. Try to maintain a fluid level in the tank above the return tee so that air cannot be continuously mixed back into the fluid. Surges of 50 psi (345 kPa) can be used to help purge air pockets by simply shutting off the return valve going into the flush cart reservoir. This “dead heads” the pump to 50 psi (345 kPa). To purge, dead head the pump until maximum pumping pressure is reached. Open the return valve and a pressure surge will be sent through the loop to help purge air pockets from the piping system.
4. Notice the drop in fluid level in the flush cart tank when the return valve is shut off. If air is adequately purged from the system, the level will drop only 1-2 inches (2.5 - 5 cm) in a 10” (25 cm) diameter PVC flush tank (about a half gallon [2.3 liters]), since liquids are incompressible. If the level drops more than this, flushing should continue since air is still being compressed in the loop fluid. Perform the “dead head” procedure a number of times.

Note: This fluid level drop is your only indication of air in the loop.

Antifreeze may be added before, during or after the flushing procedure. However, depending upon which time is chosen, antifreeze could be wasted when emptying the flush cart tank. See antifreeze section for more details.

Loop static pressure will fluctuate with the seasons. Pressures will be higher in the winter months than during the cooling season. This fluctuation is normal and should be considered when charging the system initially. Run the unit in either heating or cooling for a number of minutes to condition the loop to a homogenous temperature. This is a good time for tool cleanup, piping insulation, etc. Then, perform final flush and pressurize the loop to a static pressure of 50-75 psi [345-517 kPa] (winter) or 35-40 psi [241-276 kPa] (summer). After pressurization, be sure to loosen the plug at the end of the Grundfos loop pump motor(s) to allow trapped air to be discharged and to insure the motor housing has been flooded. This is not required for Taco circulators. Insure that the Flow Controller provides adequate flow through the unit by checking pressure drop across the heat exchanger and compare to the pressure drop tables at the back of the manual.

Antifreeze

In areas where minimum entering loop temperatures drop below 40°F [5°C] or where piping will be routed through areas subject to freezing, antifreeze is required. Alcohols and glycols are commonly used as antifreeze; however your local sales manager should be consulted for the antifreeze best suited to your area. Freeze protection should be maintained to 15°F [9°C] below the lowest expected entering loop temperature. For example, if 30°F [-1°C] is the minimum expected entering loop temperature, the leaving loop temperature would be 25 to 22°F [-4 to -6°C] and freeze protection should be at 15°F [-10°C]. Calculation is as follows:
 $30^{\circ}\text{F} - 15^{\circ}\text{F} = 15^{\circ}\text{F}$ [$-1^{\circ}\text{C} - 9^{\circ}\text{C} = -10^{\circ}\text{C}$].

All alcohols should be premixed and pumped from a reservoir outside of the building when possible or introduced under the water level to prevent fumes. Calculate the total volume of fluid in the piping system. Then use the percentage by volume shown in Table 1 for the amount of antifreeze needed. Antifreeze concentration should be checked from a well mixed sample using a hydrometer to measure specific gravity.

Low Water Temperature Cutout Setting CXM or DXM Control

When antifreeze is selected, the FP1 jumper (JW3) should be clipped to select the low temperature (antifreeze 13°F [-10.6°C]) set point and avoid nuisance faults (see “Low Water Temperature Cutout Selection” in this manual). NOTE: Low water temperature operation requires extended range equipment.

GROUND-LOOP HEAT PUMP APPLICATIONS

Table 1: Approximate Fluid Volume (U.S. gal. [L]) per 100' of Pipe

Fluid Volume (gal [liters] per 100' [30 meters] Pipe)		
Pipe	Size	Volume (gal) [liters]
Copper	1"	4.1 [15.3]
	1.25"	6.4 [23.8]
	2.5"	9.2 [34.3]
Rubber Hose	1"	3.9 [14.6]
Polyethylene	3/4" IPS SDR11	2.8 [10.4]
	1" IPS SDR11	4.5 [16.7]
	1.25" IPS SDR11	8.0 [29.8]
	1.5" IPS SDR11	10.9 [40.7]
	2" IPS SDR11	18.0 [67.0]
	1.25" IPS SCH40	8.3 [30.9]
	1.5" IPS SCH40	10.9 [40.7]
	2" IPS SCH40	17.0 [63.4]
Unit Heat Exchanger	Typical	1.0 [3.8]
Flush Cart Tank	10" Dia x 3ft tall [254mm x 91.4cm tall]	10 [37.9]

Figure 7: Loop Connection (Indoor Compressor Section)

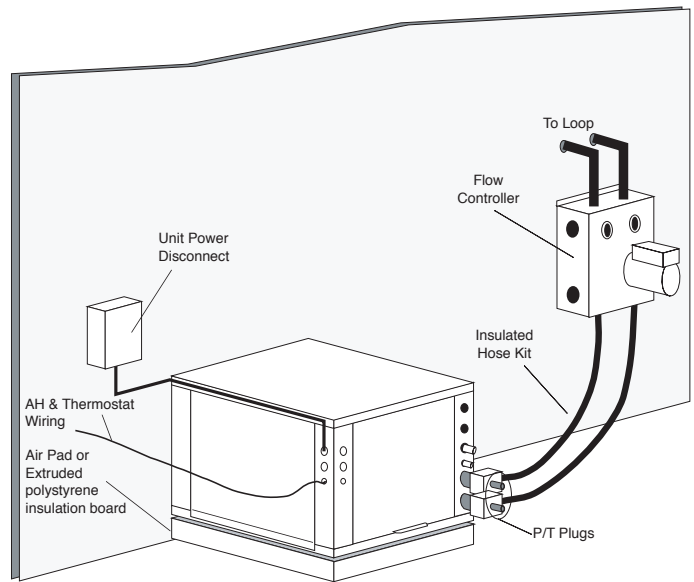
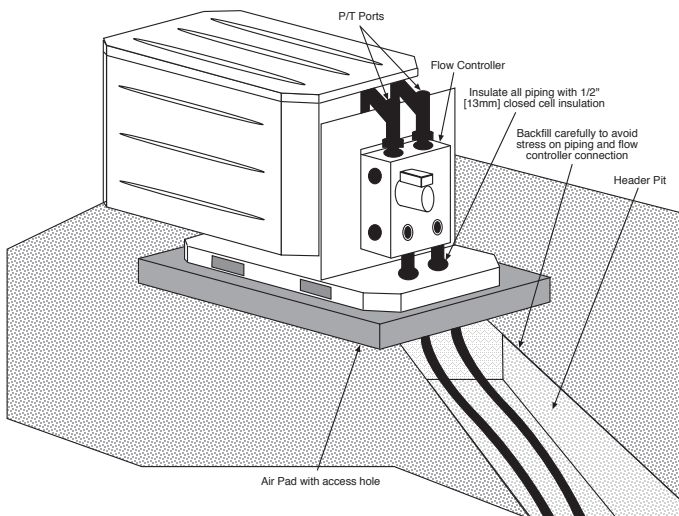

Figure 8: Loop Connection (Outdoor Compressor Section)



NOTICE! Cabinet opening around loop piping (outdoor compressor section) must be sealed to prevent entry of rodents that could potentially damage unit wiring by chewing on the insulation.

NOTICE! Outdoor compressor section may not be tilted more than 5 degrees from level. Damage to the compressor or stress on the loop piping could result if unit is tilted. A concrete pad, anchor posts and/or soil compaction may be required to avoid tilting as ground settles.

Table 2: Antifreeze Percentages by Volume

Type	Minimum Temperature for Low Temperature Protection			
	10°F [-12.2°C]	15°F [-9.4°C]	20°F [-6.7°C]	25°F [-3.9°C]
Methanol	25%	21%	16%	10%
100% USP food grade Propylene Glycol	38%	25%	22%	15%
Ethanol*	29%	25%	20%	14%

* Must not be denatured with any petroleum based product

GROUND-WATER HEAT PUMP APPLICATIONS - “INDOOR” COMPRESSOR SECTION ONLY

Open Loop - Ground Water Systems (“Indoor” Compressor Section Only)

The “outdoor” version of the compressor section may not be used with open loop systems due to potential freezing of water piping. Typical open loop piping is shown in Figure 9. Shut off valves should be included for ease of servicing. Boiler drains or other valves should be “tee’d” into the lines to allow acid flushing of the heat exchanger. Shut off valves should be positioned to allow flow through the coax via the boiler drains without allowing flow into the piping system. P/T plugs should be used so that pressure drop and temperature can be measured. Piping materials should be limited to copper or PVC SCH80. Note: Due to the pressure and temperature extremes, PVC SCH40 is not recommended.

Water quantity should be plentiful and of good quality. Consult Table 3 for water quality guidelines. The unit can be ordered with either a copper or cupro-nickel water heat exchanger. Consult Table 3 for recommendations. Copper is recommended for closed loop systems and open loop ground water systems that are not high in mineral content or corrosiveness. In conditions anticipating heavy scale formation or in brackish water, a cupro-nickel heat exchanger is recommended. In ground water situations where scaling could be heavy or where biological growth such as iron bacteria will be present, an open loop system is not recommended. Heat exchanger coils may over time lose heat exchange capabilities due to build up of mineral deposits. Heat exchangers must only be serviced by a qualified technician, as acid and special pumping equipment is required. Desuperheater coils can likewise become scaled and possibly plugged. In areas with extremely hard water, the owner should be informed that the heat exchanger may require occasional acid flushing. In some cases, the desuperheater option should not be recommended due to hard water conditions and additional maintenance required.

Water Quality Standards

Table 3 should be consulted for water quality requirements. Scaling potential should be assessed using the pH/Calcium hardness method. If the pH <7.5 and the Calcium hardness is less than 100 ppm, scaling potential is low. If this method yields numbers out of range of those listed, the Ryznar Stability and Langelier Saturation indices should be calculated. Use the appropriate scaling surface temperature for the application, 150°F [66°C] for direct use (well water/open loop) and DHW (desuperheater); 90°F [32°F] for indirect use. A monitoring plan should be implemented in these probable scaling situations. Other water quality issues such as iron fouling, corrosion prevention and erosion and clogging should be referenced in Table 3.

Expansion Tank and Pump

Use a closed, bladder-type expansion tank to minimize mineral formation due to air exposure. The expansion

tank should be sized to provide at least one minute continuous run time of the pump using its drawdown capacity rating to prevent pump short cycling. Discharge water from the unit is not contaminated in any manner and can be disposed of in various ways, depending on local building codes (e.g. recharge well, storm sewer, drain field, adjacent stream or pond, etc.). Most local codes forbid the use of sanitary sewer for disposal. Consult your local building and zoning department to assure compliance in your area.

The pump should be sized to handle the home’s domestic water load (typically 5-9 gpm [23-41 l/m]) plus the flow rate required for the heat pump. Pump sizing and expansion tank must be chosen as complimentary items. For example, an expansion tank that is too small can cause premature pump failure due to short cycling. Variable speed pumping applications should be considered for the inherent energy savings and smaller expansion tank requirements.

Water Control Valve

Note the placement of the water control valve in figure 9. Always maintain water pressure in the heat exchanger by placing the water control valve(s) on the discharge line to prevent mineral precipitation during the off-cycle. Pilot operated slow closing valves are recommended to reduce water hammer. If water hammer persists, a mini-expansion tank can be mounted on the piping to help absorb the excess hammer shock. Insure that the total ‘VA’ draw of the valve can be supplied by the unit transformer. For instance, a slow closing valve can draw up to 35VA. This can overload smaller 40 or 50 VA transformers depending on the other controls in the circuit. A typical pilot operated solenoid valve draws approximately 15VA (see Figure 24). Note the special wiring diagrams for slow closing valves (Figures 25 & 26).

Flow Regulation

Flow regulation can be accomplished by two methods. One method of flow regulation involves simply adjusting the ball valve or water control valve on the discharge line. Measure the pressure drop through the unit heat exchanger, and determine flow rate from Tables 11a through 11c. Since the pressure is constantly varying, two pressure gauges may be needed. Adjust the valve until the desired flow of 1.5 to 2 gpm per ton [2.0 to 2.6 l/m per kW] is achieved. A second method of flow control requires a flow control device mounted on the outlet of the water control valve. The device is typically a brass fitting with an orifice of rubber or plastic material that is designed to allow a specified flow rate. On occasion, flow control devices may produce velocity noise that can be reduced by applying some back pressure from the ball valve located on the discharge line. Slightly closing the valve will spread the pressure drop over both devices, lessening the velocity noise. NOTE: When EWT is below 50°F [10°C], 2 gpm per ton (2.6 l/m per kW) is required.

GROUND-WATER HEAT PUMP APPLICATIONS

Water Coil Low Temperature Limit Setting

For all open loop systems the 30°F [-1.1°C] FP1 setting (factory setting-water) should be used to avoid freeze damage to the unit. See “Low Water Temperature Cutout Selection” in this manual for details on the low limit setting.

⚠ CAUTION! ⚠

CAUTION! Many units installed with a factory or field supplied manual or electric shut-off valve. **DAMAGE WILL OCCUR** if shut-off valve is **closed** during unit operation. A high pressure switch must be installed on the heat pump side of any field provided shut-off valves and connected to the heat pump controls in series with the built-in refrigerant circuit high pressure switch to disable compressor operation if water pressure exceeds pressure switch setting. The field installed high pressure switch shall have a cut-out pressure of 235 psig and a cut-in pressure of 190 psig. This pressure switch can be ordered with a 1/4” internal flare connection as part number 39B0005N01.

⚠ CAUTION! ⚠

CAUTION! Refrigerant pressure activated water regulating valves should never be used with geothermal heat pump equipment.

Figure 9: Water Well Connections

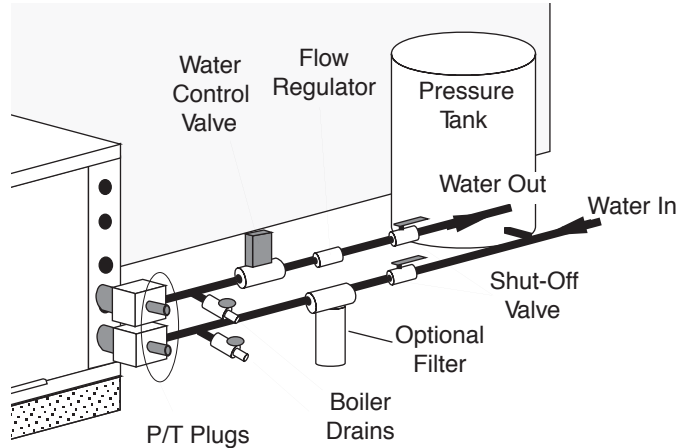

WATER QUALITY STANDARDS

Table 3: Water Quality Standards

Water Quality Parameter	HX Material	Closed Recirculating	Open Loop and Recirculating Well		
Scaling Potential - Primary Measurement					
Above the given limits, scaling is likely to occur. Scaling indexes should be calculated using the limits below.					
pH/Calcium Hardness Method	All	-	pH < 7.5 and Ca Hardness <100ppm		
Index Limits for Probable Scaling Situations - (Operation outside these limits is not recommended)					
Scaling indexes should be calculated at 150°F [66°C] for direct use and HWG applications, and at 90°F [32°C] for indirect HX use. A monitoring plan should be implemented.					
Ryznar Stability Index	All	-	6.0 - 7.5 If >7.5 minimize steel pipe use.		
Langelier Saturation Index	All	-	-0.5 to +0.5 If <-0.5 minimize steel pipe use. Based upon 150°F [66°C] HWG and Direct well, 85°F [29°C] Indirect Well HX		
Iron Fouling					
Iron Fe ²⁺ (Ferrous) (Bacterial Iron potential)	All	-	<0.2 ppm (Ferrous) If Fe ²⁺ (ferrous)>0.2 ppm with pH 6 - 8, O ₂ <5 ppm check for iron bacteria		
Iron Fouling	All	-	<0.5 ppm of Oxygen Above this level deposition will occur.		
Corrosion Prevention					
pH	All	6 - 8.5 Monitor/treat as needed	6 - 8.5 Minimize steel pipe below 7 and no open tanks with pH <8		
Hydrogen Sulfide (H ₂ S)	All	-	<0.5 ppm At H ₂ S>0.2 ppm, avoid use of copper and copper nickel piping or HX's. Rotten egg smell appears at 0.5 ppm level. Copper alloy (bronze or brass) cast components are OK to <0.5 ppm.		
Ammonia ion as hydroxide, chloride, nitrate and sulfate compounds	All	-	<0.5 ppm		
Maximum Chloride Levels	Maximum Allowable at maximum water temperature.				
			50°F (10°C)	75°F (24°C)	100°F (38°C)
	Copper	-	<20ppm	NR	NR
	CuproNickel	-	<150 ppm	NR	NR
	304 SS	-	<400 ppm	<250 ppm	<150 ppm
316 SS	-	<1000 ppm	<550 ppm	< 375 ppm	
Titanium	-	>1000 ppm	>550 ppm	>375 ppm	
Erosion and Clogging					
Particulate Size and Erosion	All	<10 ppm of particles and a maximum velocity of 6 fps [1.8 m/s]. Filtered for maximum 800 micron [800mm, 20 mesh] size.	<10 ppm (<1 ppm "sandfree" for reinjection) of particles and a maximum velocity of 6 fps [1.8 m/s]. Filtered for maximum 800 micron [800mm, 20 mesh] size. Any particulate that is not removed can potentially clog components.		

Notes:

- Closed Recirculating system is identified by a closed pressurized piping system.
- Recirculating open wells should observe the open recirculating design considerations.
- NR - Application not recommended.

Rev.: 11/17/06D

REFRIGERATION INSTALLATION

⚠ CAUTION! ⚠

CAUTION! R-410A systems operate at higher pressures than R-22 systems. Be certain that service equipment (gauges, tools, etc.) is rated for R-410A. Some R-22 service equipment may not be acceptable.

⚠ CAUTION! ⚠

CAUTION! Installation of a factory supplied liquid line bi-directional filter drier is required. Never install a suction line filter in the liquid line.

A reversible heat pump filter drier is installed on the liquid line inside the compressor section cabinet (R-22 units only). R-410A models are shipped with a filter drier (loose) inside the cabinet that must be installed in the liquid line at the line set. **All brazing should be performed using nitrogen circulating at 2-3 psi [13.8-20.7 kPa] to prevent oxidation inside the tubing. All linesets should be insulated with a minimum of 1/2" [13mm] thick closed cell insulation. All insulation tubing should be sealed using a UV resistant paint or covering to prevent deterioration from sunlight.**

When passing refrigerant lines through a wall, seal opening with silicon-based caulk. Avoid direct contact with water pipes, duct work, floor joists, wall studs, floors or other structural components that could transmit compressor vibration. Do not suspend refrigerant tubing from joists with rigid straps. Do not attach line set to the wall. When necessary, use hanger straps with isolation sleeves to minimize transmission of line set vibration to the structure.

Line Set Installation

Figures 12a through 13b illustrate typical installations with the "indoor" and "outdoor" versions of the compressor section matched to either an air handler (fan coil) or add-on furnace coil. Table 4 shows typical line-set diameters at various lengths. Lineset lengths should be kept to a minimum and should always be installed with care to avoid kinking. Line sets over 60 feet [18 meters] long are not recommended due to potential oil transport problems and excessive pressure drop. If the line set is kinked or distorted, and it cannot be formed back into its original shape, the damaged portion of the line should be replaced. A restricted line set will effect the performance of the system.

Installing the Lineset at the Compressor Section

Braze the line set to the service valve stubs as shown in Figure 10. On installations with long line sets, copper adapters may be needed to connect the larger diameter tube to the stubs. Nitrogen should be circulated through the system at 2-3 psi [13.8-20.7 kPa] to prevent oxidation contamination. Use a low silver phos-copper braze alloy on all brazed connections. **Compressor section is shipped with a factory charge. Therefore, service valves should not be opened until the line set has been leak tested, purged and evacuated.** See "Charging the System."

Table 4: Lineset Diameters and Charge Information

Model	Factory† Charge (oz) [kg]	Basic* Charge (oz) [kg]	20 Feet [6 meters]		40 Feet [12 meters]		60 Feet [18 meters]	
			Liquid	Suction	Liquid	Suction	Liquid	Suction
50YCS/38WQS Series								
018	70 [1.98]	55 [1.56]	3/8"	3/4"	3/8"	3/4"	3/8"	3/4"
024	74 [2.10]	59 [1.67]	3/8"	3/4"	3/8"	3/4"	3/8"	7/8"
030	108 [3.06]	93 [2.64]	3/8"	3/4"	3/8"	7/8"	3/8"	7/8"
036	117 [3.32]	102 [2.89]	3/8"	3/4"	3/8"	7/8"	3/8"	7/8"
042	122 [3.46]	107 [3.03]	3/8"	7/8"	3/8"	7/8"	3/8"	7/8"
048	130 [3.69]	115 [3.26]	3/8"	7/8"	3/8"	7/8"	1/2"	1-1/8"
060	136 [3.86]	121 [3.43]	3/8"	1-1/8"	1/2"	1-1/8"	1/2"	1-1/8"
50YDS Series								
026	90 [2.55]	75 [2.13]	3/8"	3/4"	3/8"	3/4"	3/8"	7/8"
038	104 [2.95]	89 [2.52]	3/8"	7/8"	3/8"	7/8"	3/8"	7/8"
049	126 [3.57]	111 [3.15]	3/8"	7/8"	3/8"	7/8"	1/2"	1-1/8"
064	168 [4.76]	138 [3.91]	1/2"	1-1/8"	1/2"	1-1/8"	1/2"	1-1/8"

* Basic charge includes only the amount required for the condensing unit and the evaporating coil. An additional amount should be added allowing 0.6oz per ft. for 3/8" [0.6g per cm] and 1.2oz per ft. for 1/2" [1.1g per cm] of lineset used.
† Factory charge is preset for 25' [7.6 meters] lineset.

REFRIGERATION INSTALLATION

Figure 10: Braze Instructions

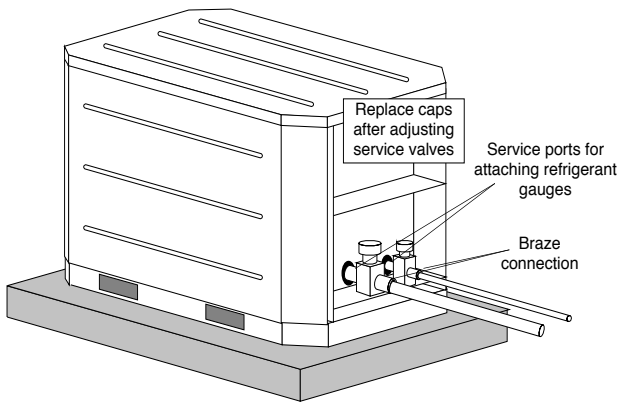
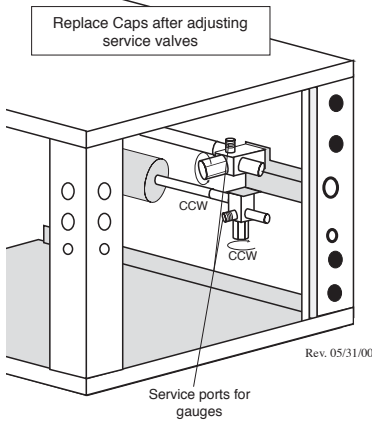
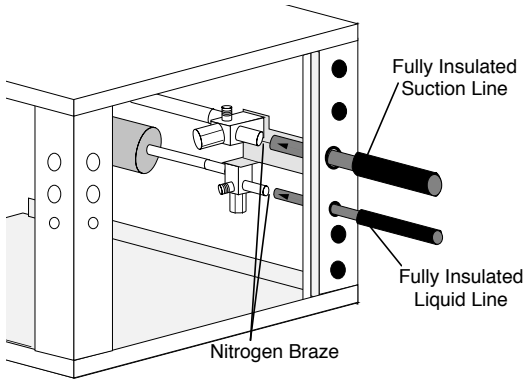
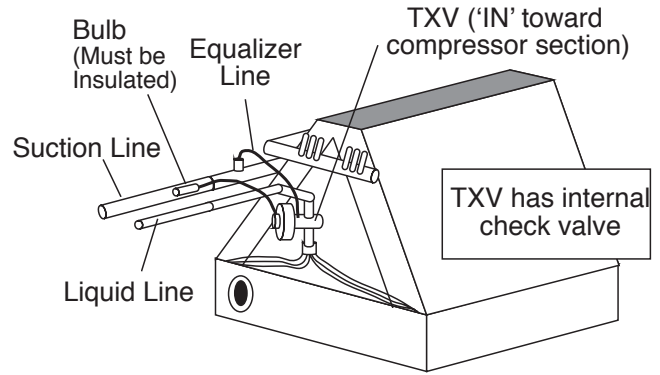

Figure 11: Air Coil Connection



Add-On Heat Pump Applications

The indoor coil should be located in the supply side of the furnace to avoid condensation damage to the furnace heat exchanger for add-on heat pump applications. A high temperature limit switch should be installed as shown in Figures 12b and 13b just upstream of the coil to de-energize the compressor any time the furnace is energized to avoid blowing hot air directly into the coil, elevating refrigerant pressures during operation. The heat pump will trip out on high pressure lockout without some method of disengaging the compressor during furnace operation. Alternatively, some thermostats with “dual fuel” mode will automatically de-energize the compressor when second stage (backup) heat is required.

The TXV should be brazed into place as shown in Figure 11, keeping the “IN” side toward the compressor section. The TXV has an internal check valve and must be installed in the proper direction for operation. Always keep the valve body cool with a brazing shield and wet rags to prevent damage to the TXV. Attach the bulb to the suction line using the supplied hose clamp. Be careful not to overtighten the clamp and deform the bulb.

NOTICE! The air coil should be thoroughly washed with a filming agent, (dishwasher detergent like Cascade) to help condensate drainage. Apply a 20 to 1 solution of detergent and water. Spray both sides of coil, repeat and rinse thoroughly with water.

Table 5: Service Valve Positions

Position	Description	System	Service Port
CCW - Full Out	Operation Position	Open	Closed
CCW - Full Out 1/2 turn CW	Service Position	Open	Open
CW - Full In	Shipping Position	Closed	Open

Installing the Indoor Coil and Lineset

Figure 11 shows the installation of the lineset and TXV to a typical indoor coil. An indoor coil or air handler (fan coil) with a TXV is preferred. Coils with cap tubes may not be used. If coil includes removable fixed orifice, the orifice must be removed and a TXV must be installed as shown in Figure 11. Fasten the copper line set to the coil. Nitrogen should be circulated through the system at 2-3 psi [13.8-20.7 kPa] to prevent oxidation inside the refrigerant tubing. Use a low silver phos-copper braze alloy on all brazed connections.

Evacuation and Charging the Unit

LEAK TESTING - The refrigeration line set must be pressurized and checked for leaks before evacuating and charging the unit. To pressurize the line set, attach refrigerant gauges to the service ports and add an inert gas (nitrogen or dry carbon dioxide) until pressure reaches 60-90 psig [413-620 kPa]. Never use oxygen or acetylene to pressure test. Use a halogen leak tester or a good quality bubble solution to detect leaks on all connections made in the field. Check the service valve ports and stem for leaks. If a leak is found, repair it and repeat the above steps. For safety reasons do not pressurize system above 150 psig [1034 kPa]. System is now ready for evacuation and charging.

REFRIGERATION INSTALLATION

Figure 12a: Typical Split / Air Handler Installation (Indoor Compressor Section)

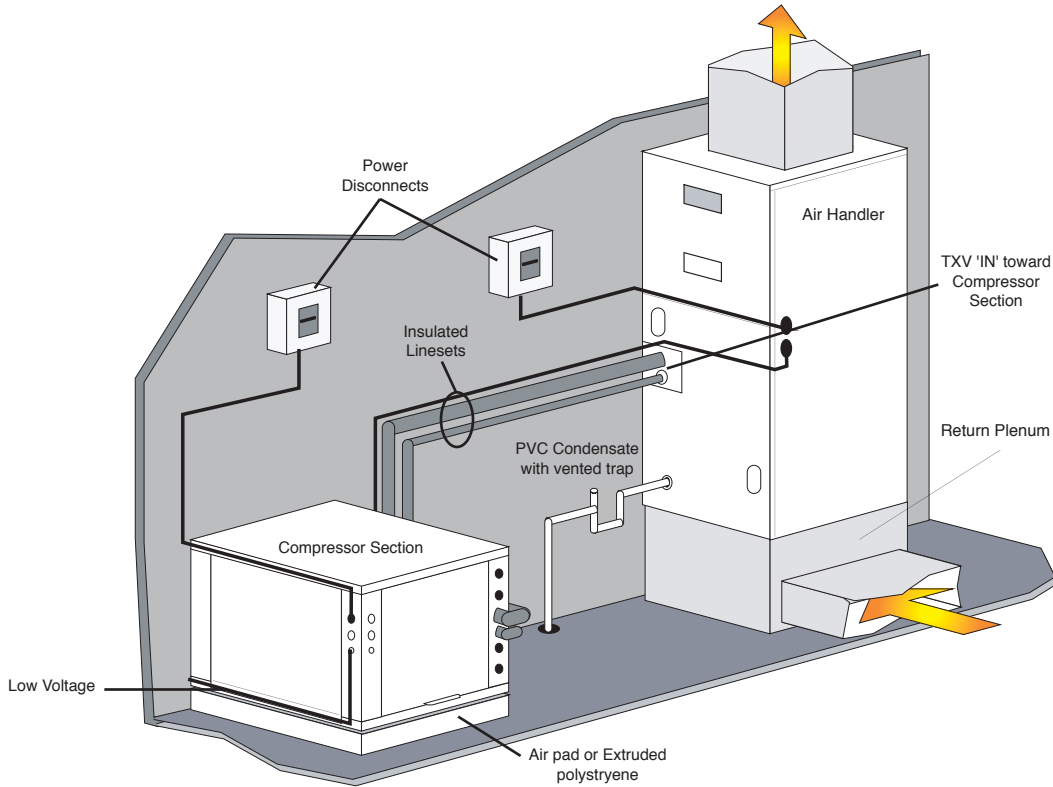
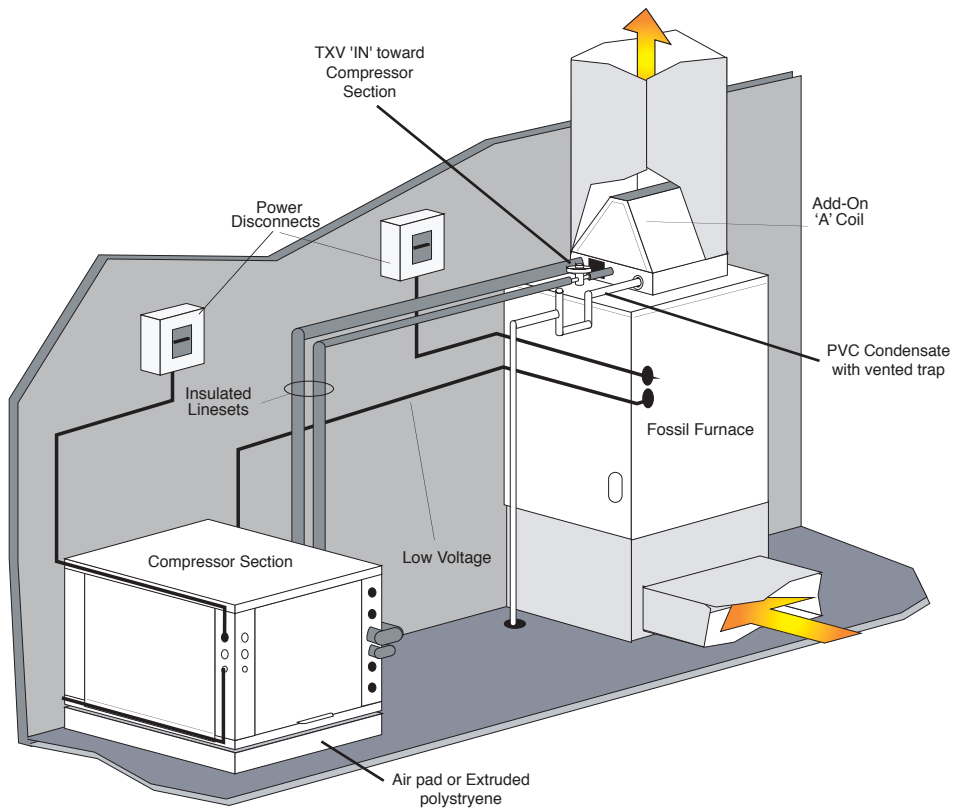

Figure 12b: Typical Split / Add-on Coil Fossil Fuel Furnace Installation (Indoor Compressor Section)



REFRIGERATION INSTALLATION

Figure 13a: Typical Split / Air Handler Installation (Outdoor Compressor Section)

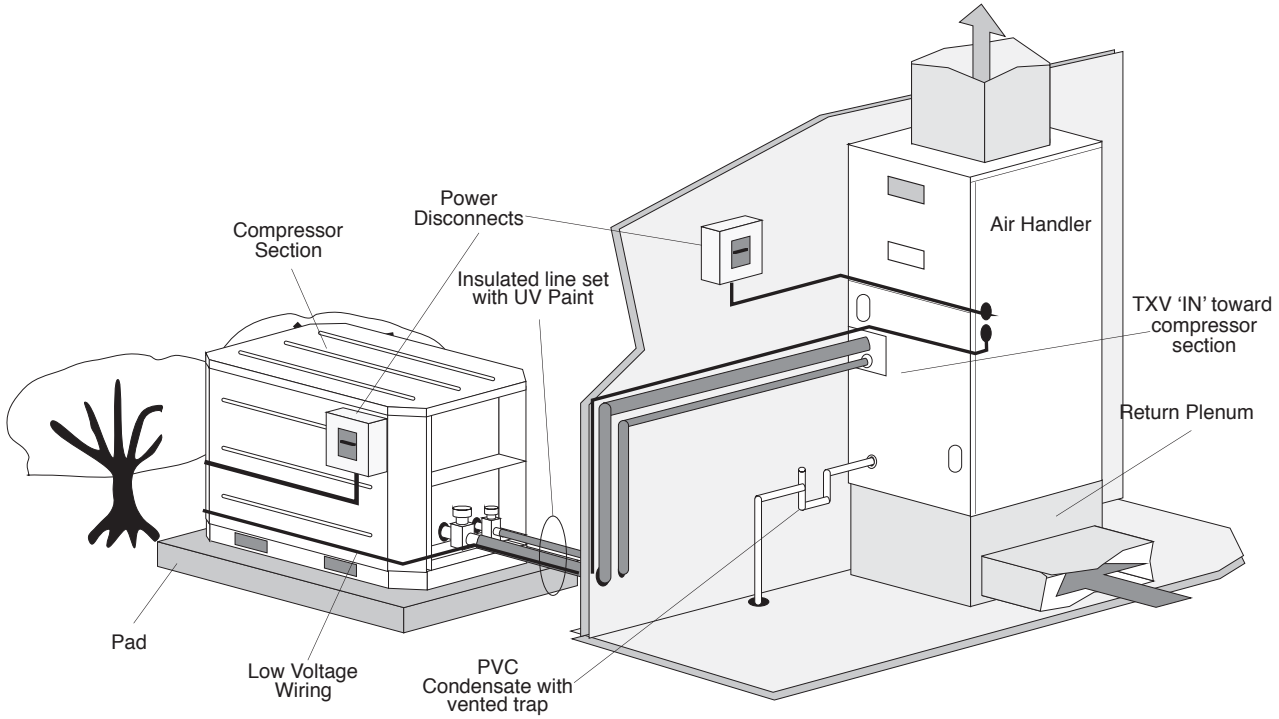
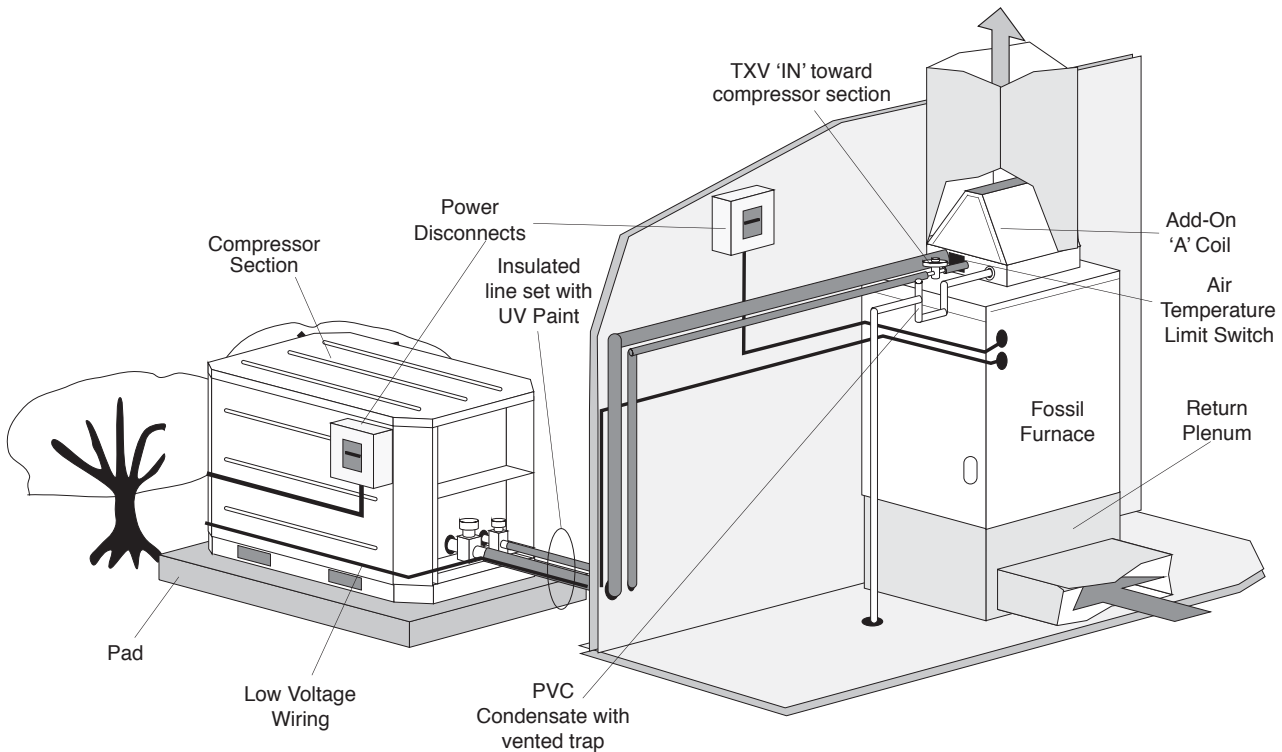

Figure 13b: Typical Split / Add-on Coil Fossil Fuel Furnace Installation (Outdoor Compressor Section)



REFRIGERATION INSTALLATION

Evacuation Of The Lineset And Coil

The line set and coil must be evacuated to at least 500 microns to remove any moisture and noncondensables. Evacuate the system through both service ports in the shipping position (full CW in - see table 5) to prevent false readings on the gauge because of pressure drop through service ports. A vacuum gauge or thermistor capable of accurately measuring the vacuum depth is crucial in determining if the system is ready for charging. If the system meets the requirements in Figure 14, it is ready for charging.

Figure 14: Evacuation Graph

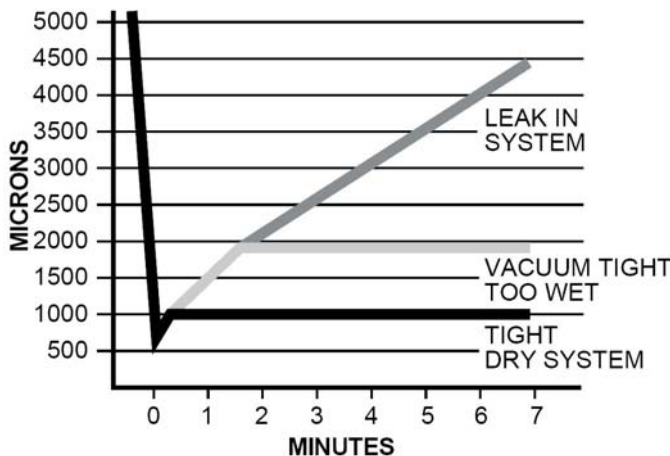

Charging The System

There are two methods of charging a refrigerant system. One method is the total charge method, where the volume of the system is determined and the refrigerant is measured and added into the evacuated system. The other method is the partial charge method where a small initial charge is added to an evacuated system, and remaining refrigerant added during operation.

TOTAL CHARGE METHOD - See Table 4 for the compressor section basic charge. For line sets with 3/8" liquid lines add 0.6 ounces of refrigerant to the basic charge for every installed foot of liquid line [0.6 grams per cm]. Add 1.2 oz. per foot [1.1 grams per cm] if using 1/2" line. Once the total charge is determined, the factory pre-charge (Table 4) is subtracted and the remainder is the amount needed to be added to the system. This method should be used with the ARI matched air handler.

EXAMPLE: R22 model 048 with 40 feet [12 meters] of installed liquid line (3/8" O.D.). The basic charge of model 048 is 115 oz [3.26 kg]. The 40 ft. [12 meter] 3/8" line set requires 24 oz. [0.72 kg] (40 ft. x 0.6 oz./ft = 24 oz. -- 1200cm x 0.6g/cm = 720g). Total charge = 115 + 24 = 139 oz [3.26 + 0.72 = 3.98 kg]. The compressor section is shipped from the factory with 130 oz. [3.69 kg] of refrigerant (for 25 ft [7.6m] lineset), so the amount to be added is 9 oz. [0.29 kg] (total charge - shipped charge = charge to be added).

Table 6a: R-22 Charging Values

▲ NOTICE! ▲

NOTICE: Use tables 14a to 15 for superheat/subcooling values. These tables use discharge pressure (converted to saturation temperature) and liquid line temperature for subcooling calculations. If using liquid line pressure, subtract 3°F from the table values.

Table 6b: R-410A Charging Values

▲ NOTICE! ▲

NOTICE: Use tables 14a to 15 for superheat/subcooling values. These tables use discharge pressure (converted to saturation temperature) and liquid line temperature for subcooling calculations. If using liquid line pressure, subtract 3°F from the table values.

REFRIGERATION INSTALLATION

Turn service valves full out CCW (see Table 5) and then turn back in one-half turn to open service ports. Add the required refrigerant so that the total charge calculated for the unit and line set is now in the system. Open the service valve fully counter clockwise so that the stem will backseat and prevent leakage through the schrader port while it is not in use. Start unit in the heating mode and measure superheat and subcooling values after 5 minutes of run time. See tables 13a to 14 for superheat and sub-cooling values. Superheat is measured using suction temperature and pressure at the compressor suction line. Subcooling should be measured using the liquid line temperature immediately outside the compressor section cabinet and either the liquid line service valve pressure or the compressor discharge pressure. Note that different values from tables 13a to 14 will be obtained due to the pressure losses through the condenser heat exchanger. Adding refrigerant will increase sub-cooling while superheat should remain fairly constant allowing for a slight amount of hunting in TXV systems. This increase in subcooling will require 5 minutes or so of operation before it should be measured. After values are measured, compare to the chart and go to "FINAL EVALUATION."

PARTIAL CHARGE METHOD - Open service valve fully counterclockwise and then turn back in one-half turn to open service port. Add vaporized (Gas) into the suction side of the compressor until the pressure in the system reaches approximately 60-70 psig (R-22 systems) or 100-120 psig (R-410A systems). Never add liquid refrigerant into the suction side of a compressor. Start the unit in heating and add gas to the suction port at a rate not to exceed five pounds [2.27 kg] per minute. Keep adding refrigerant until the complete charge has been entered. Superheat is measured using suction temperature and pressure at the compressor suction line. Subcooling should be measured using the liquid line temperature immediately outside the compressor section cabinet and either the liquid line service valve pressure or the compressor discharge pressure. Note that different values from tables 13a to 14 will be obtained due to the pressure losses through the condenser heat exchanger. Adding refrigerant will increase sub-cooling while superheat should remain fairly constant allowing for a slight amount of hunting in TXV systems. This increase in subcooling will require 5 minutes or so of operation before it should be measured. After values are measured, compare to the chart and go to "FINAL EVALUATION."

FINAL EVALUATION -In a split system, cooling subcooling values can be misleading depending on the location of the measurement. Therefore, it is recommended that charging be monitored in the heating mode. Charge should be evaluated by monitoring the subcooling in the heating mode. After initial check of heating sub-cooling, shut off unit and allow to sit 3-5 minutes until pressures equalize. Restart unit in the

cooling mode and check the cooling superheat against Tables 13a to 14. If unit runs satisfactorily, charging is complete. If unit does not perform to specifications the cooling TXV (air coil side) may need to be readjusted (if possible) until the cooling superheat values are met.

Checking Superheat and Subcooling

Determining Superheat:

1. Measure the temperature of the suction line at a point near the expansion valve bulb.
2. Determine the suction pressure by attaching refrigeration gauges to the suction schrader connection at the compressor.
3. Convert the pressure obtained in step 2 to saturation temperature (boiling point) by using the pressure/temperature conversion table on the gauge set.
4. Subtract the temperature obtained in step 3 from step 1. The difference will be the superheat of the unit or the total number of degrees above saturation temperature. Refer to Tables 13a to 14 for superheat ranges at specific entering water conditions.

Example (R-22 refrigerant):

The temperature of the suction line at the sensing bulb is 50°F. The suction pressure at the compressor is 65 psig which is equivalent to 38°F saturation temperature from the R-22 press/temp conversion table on the gauge set. 38°F subtracted from 50°F = 12°F Superheat.

Determining Sub-Cooling:

1. Measure the temperature of the liquid line on the smaller refrigerant line (liquid line) just outside of the cabinet. This location will be adequate for measurement in both modes unless a significant temperature drop in the liquid line is anticipated.
2. Determine the condenser pressure (high side) by attaching refrigerant gauges to the schrader connection on the liquid line service valve. If the hot gas discharge line of the compressor is used, refer to the appropriate column in Tables 13a to 14.
3. Convert the pressure obtained in step 2 to the saturation temperature by using the press/temp conversion table on the gauge set.
4. Subtract the temperature of Step 3 from the temperature of Step 1. The difference will be the sub-cooling value for that unit (total degrees below the saturation temperature). Refer to Tables 13a or 6b for sub-cooling values at specific entering water temperatures.

Example (R-22 refrigerant):

The condenser pressure at the service port is 225 psig, which is equivalent to 110°F saturation temperature. Discharge pressure is 236 psig at the compressor (113°F saturation temperature). Measured liquid line temperature is 100°F. 100°F subtracted from 110°F = 10 degrees sub-cooling (13 degrees if using the compressor discharge pressure).

HOT WATER GENERATOR

The HWG (Hot Water Generator) or desuperheater option provides considerable operating cost savings by utilizing excess heat energy from the heat pump to help satisfy domestic hot water requirements. The HWG is active throughout the year, providing virtually free hot water when the heat pump operates in the cooling mode or hot water at the COP of the heat pump during operation in the heating mode. Actual HWG water heating capacities are provided in the appropriate heat pump performance data.

“Indoor” compressor section heat pumps equipped with the HWG option include a built-in water to refrigerant heat exchanger that eliminates the need to tie into the heat pump refrigerant circuit in the field. The control circuit and pump are also built in for residential equipment. Figure 15 shows a typical example of HWG water piping connections on a unit with built-in pump. This piping layout minimizes scaling potential.

The outdoor compressor section utilizes an add-on HWG module that ties into the hot gas line of the compressor section. The HWG module is remotely mounted near the water heater and includes a water to refrigerant heat exchanger, pump and controls. Figure 18 is a typical example of a remote module HWG system.

Electric water heaters are recommended. If a gas, propane, or oil water heater is used, a second preheat tank must be installed (Figure 16). If the electric water heater has only a single center element, the dual tank system is recommended to insure a usable entering water temperature for the HWG.

Typically a single tank of at least 52 gallons (235 liters) is used to limit installation costs and space. However, a dual tank, as shown in Figure 16, is the most efficient system, providing the maximum storage and temperate source water to the HWG. Using a concentric or coaxial hot water

tank connection fitting eliminates the need to tie into the hot water tank cold water piping, but is more susceptible to scaling. The optional concentric fitting (part # S69619804) is available from your equipment supplier and should be installed as shown in Figure 17 for applications with low scaling potential or where a water softener is used. Consult Table 3 for scaling potential tests.

It is always advisable to use water softening equipment on domestic water systems to reduce the scaling potential and lengthen equipment life. In extreme water conditions, it may be necessary to avoid the use of the HWG option since the potential cost of frequent maintenance may offset or exceed any savings.

R-410 systems inherently have a lower hot gas temperature than R-22 systems because the equipment is more efficient (i.e. less waste heat is available). It is possible that energy could be transferred from the water heater to the hot gas line instead of from the hot gas line to the water heater during certain times of the year. To prevent this from occurring, a temperature switch will deactivate the pump at those conditions that typically occur in the cooling mode with entering water temperatures of less than 50°F [10°C].

Installation

The HWG high limit temperature switch is set at 125°F [52°C] and is located on the HWG heat exchanger “Water In” line. If the HWG is connected incorrectly or if circulation is reversed, the aquastat will sense leaving water temperature and prevent HWG operation. **UNDER NO CIRCUMSTANCES SHOULD THE LIMIT BE DISCONNECTED OR REMOVED!** Full load conditions could drive hot water tank temperatures far above desirable temperature levels if the aquastat has been disconnected or removed.

Figure 15: Typical HWG Installation (Indoor Compressor Section)

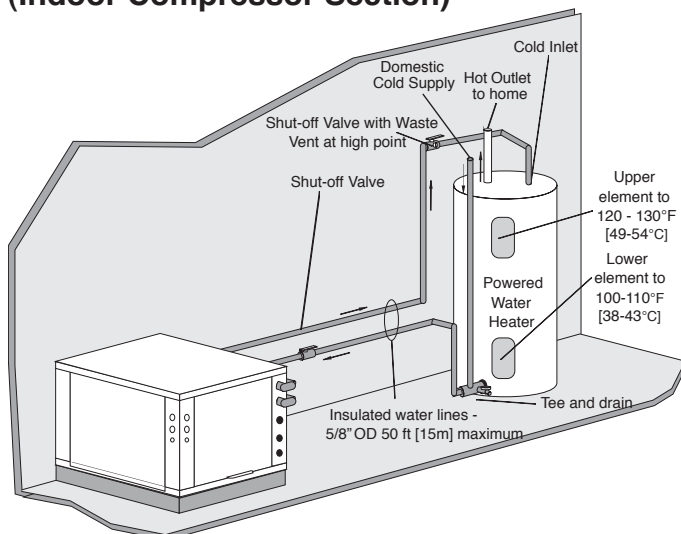
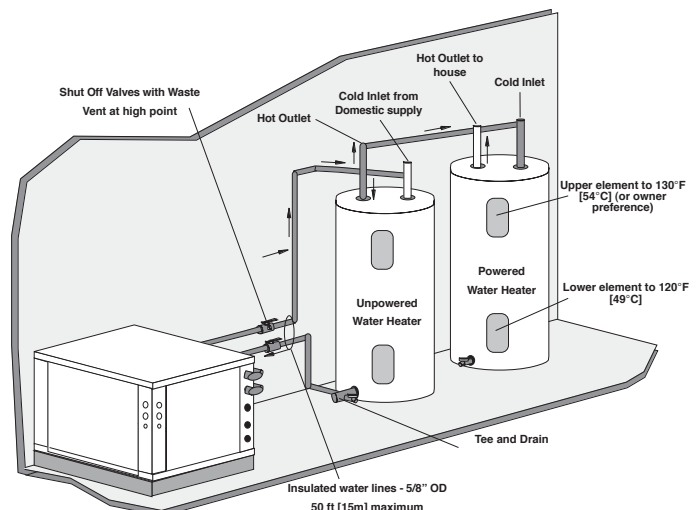
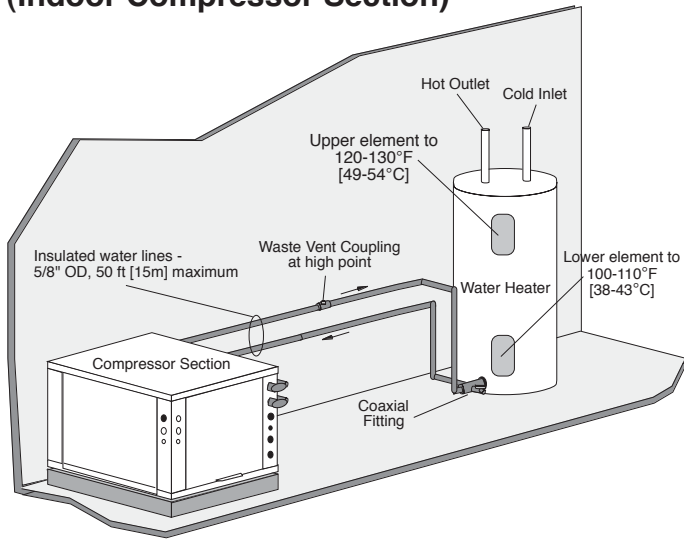

Figure 16: HWG Double Tank Installation (Indoor Compressor Section)



HOT WATER GENERATOR

Figure 17: Alternate HWG Piping with concentric/coaxial fitting (part #S69619804 not included with unit) (Indoor Compressor Section)



The heat pump, water piping, pump, and hot water tank should be located where the ambient temperature does not fall below 50°F [10°C]. Keep water piping lengths at a minimum. DO NOT use a one way length greater than 50 ft. [15 m].

All installations must be in accordance with local codes. The installer is responsible for knowing the local requirements, and for performing the installation accordingly. DO NOT connect the pump wiring until “Initial Start-Up” section, below. Powering the pump before all installation steps are completed will damage the pump.

Water Tank Preparation

1. Turn off power or fuel supply to the hot water tank.
2. Connect a hose to the drain valve on the water tank.
3. Shut off the cold water supply to the water tank.
4. Open the drain valve and open the pressure relief valve or a hot water faucet to drain tank.
5. When using an existing tank, it should be flushed with cold water after it is drained until the water leaving the drain hose is clear and free of sediment.
6. Close all valves and remove the drain hose.
7. Install HWG water piping.

HWG Water Piping

1. Using at least 5/8” [16mm] O.D. copper, route and install the water piping, valves and air vent as shown in Figures 15 to 18. The air vent MUST be at the high point of the HWG water piping.
2. Insulate all HWG water piping with no less than 3/8” [10mm] wall closed cell insulation.
3. Open both shut off valves and make sure the tank drain valve is closed.

Water Tank Refill

1. Open the cold water supply to the tank.
2. Open a hot water faucet to vent air from the system until water flows from the faucet; turn off faucet.
3. Depress the hot water tank pressure relief valve handle to ensure that there is no air remaining in the tank.
4. Inspect all work for leaks.
5. Before restoring power or fuel supply to the water heater, adjust the temperature setting on the tank thermostat(s) to insure maximum utilization of the heat available from the refrigeration system and conserve the most energy. On tanks with both upper and lower elements and thermostats, the lower element should be turned down to 100°F [38°C] or the lowest setting; the upper element should be adjusted to 120-130°F [49-54°C]. Depending upon the specific needs of the customer, you may want to adjust the upper element differently. On tanks with a single thermostat, a preheat tank should be used (figure 16).
6. Replace access cover(s) and restore power or fuel supply.

Initial Start-Up

1. Make sure all valves in the HWG water circuit are fully open.
2. Turn on the heat pump and allow it to run for 10-15 minutes.
3. Turn the heat pump and heat pump power supply “OFF” and CONNECT POWER TO THE HWG PUMP as shown in the unit wiring diagram. Connect the pump power lead as instructed on the tag attached to the pump wiring.
4. The HWG pump should not run if the compressor is not running.
5. The temperature difference between the water entering and leaving the HWG coil should be approximately 5-10°F [3-6°C].
6. Allow the unit to operate for 20 to 30 minutes to insure that it is functioning properly.

Figure 18: HWG Installation (shown with optional concentric/coaxial fitting part #S69619804 not included with unit) (Outdoor Compressor Section)

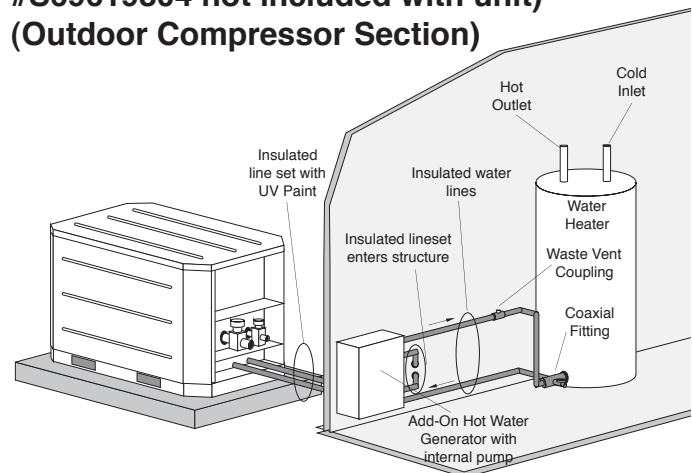

HWG MODULE REFRIGERATION INSTALLATION - OUTDOOR COMPRESSOR SECTION ONLY

General Information

The HWG Module consists of an all-copper, vented double-wall heat exchanger and a water-cooled water circulating pump. The pump is controlled by the use of one or more limit switches. Power for the pump is provided from either the compressor contactor of the outdoor section of the heat pump, or it may come from a remote power source if the appropriate controls are used.

Location/Mounting

The HWG module should be mounted as close to the heat pump outdoor section as possible, in order to minimize the length of refrigerant run. Indoor mounting is preferred, where practical, to reduce the likelihood of freezing ambient temperature. It is recommended that the HWG module be mounted above the system compressor in order to promote proper oil movement and drain-down.

This means that the HWG module can be wall mounted in any orientation except for stubs up. Mounting should be accomplished by fastening the HWG module cabinet to the wall or other selected vertical surface. A flange is provided at the top rear of the unit. Any fastener suitable for supporting a 12 pound [5.4] vertical load is acceptable.

SPECIAL NOTE: The selected mounting location and orientation must allow the circulator pump to be positioned with the motor shaft horizontal. **DO NOT install the Heat Recovery Unit flat on its back.**

Refrigerant Line Installation

Before starting the installation into the refrigerant circuit, inspect and note the condition and performance of the heat pump. Disconnect power to the heat pump outdoor unit. Any system deficiencies must be corrected prior to installing the HWG module. Addition of the unit will not correct system problems. Record the suction and discharge pressures and compressor amperage draw. These will be used for comparison with system operation after the refrigerant line installation is complete and before the water line installation is performed. Install the Add-On HWG kit using the installation instructions below. Locate the HWG as close to the water heater as possible. Unbraid the hot gas u-bend as shown in Figure 19. Take care to avoid overheating components. Install the dual 1/2" lineset to the HWG. Maximum length should be 30 feet one way. Evacuate the lineset to 500 microns through the hot gas valves in the outdoor unit. Open the valves up fully (CCW looking up from cap end). Check the lineset for leaks. Pinch the bypass tubing as shown in Figure 19 being careful not to damage the tubing. Verify that lineset tubing is completely insulated with a minimum 1/2" thick closed cell and painted to prevent deterioration of the insulation due to ultra violet light and weather. Make the connections with high temperature solder or brazing rod. The recommended line size is dependent on the one way distance between the Heat Recovery Unit and the compressor; and the size of the system. Use the Table 7 as a guideline.

Table 7: HWG Module Lineset Sizing

Capacity	Line Set Size		
	1/2" OD	5/8" OD	3/4" OD
2 Ton	Up to 16 ft. [4.9m]	Up to 30 ft. [9.1m]	N/A
3 Ton	Up to 9 ft. [2.7m]	Up to 25 ft. [7.6m]	Up to 30 ft. [9.1m]
4 Ton	Up to 5 ft. [1.5m]	Up to 13 ft. [4.0m]	Up to 30 ft. [9.1]
5 Ton	N/A	Up to 9 ft. [2.7m]	Up to 25 ft. [7.6m]

As a guideline add 1.0 oz. of R-22 for the heat exchanger plus 1.0 oz. for each 10 ft of 1/2" OD refrigerant line, if the weighed charge method is used (28g for the heat exchanger plus 9g per meter of 1/2" OD refrigerant line).

Figure 19: HWG Connection Details

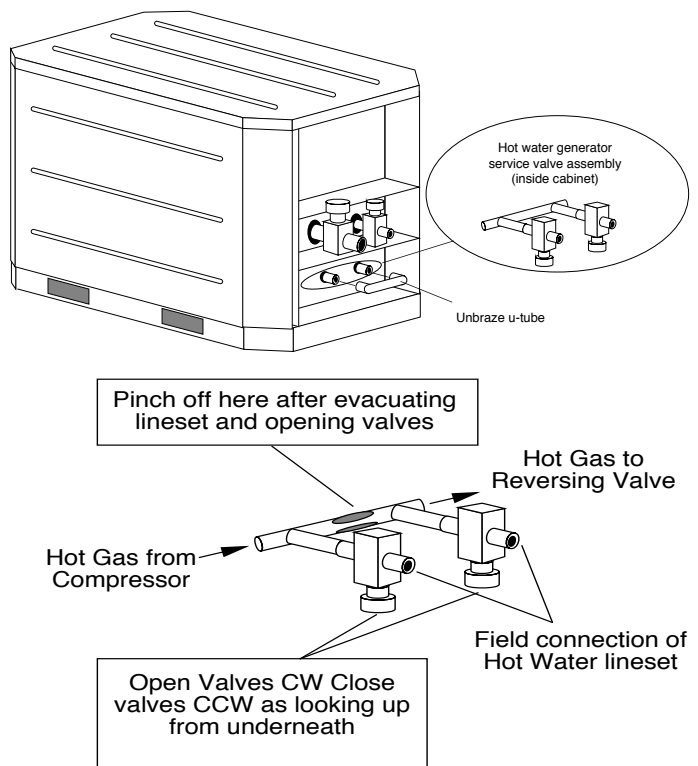

HWG MODULE REFRIGERATION INSTALLATION - OUTDOOR COMPRESSOR SECTION ONLY

Figure 20: HWG Module Wiring

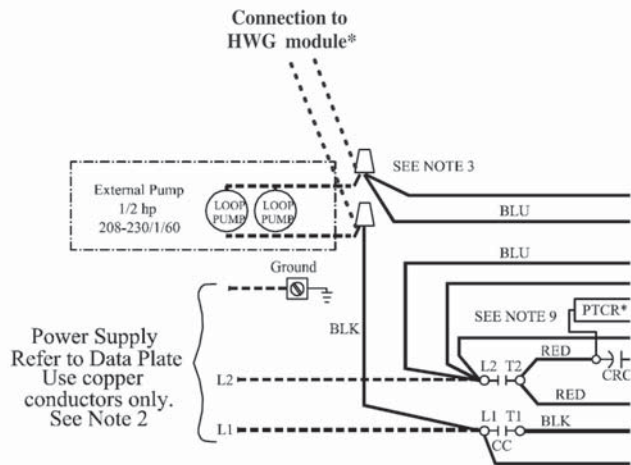

*Provide a safety disconnect switch near the HWG module.

⚠ WARNING! ⚠

WARNING! The HWG module is an appliance that operates in conjunction with the heat pump system, the hot water system and the electrical system. Installation should only be performed by skilled technicians with appropriate training and experience. The installation must be in compliance with local codes and ordinances. Local plumbing and electrical building codes take precedence over instructions contained herein. The Manufacturer accepts no liability for equipment damaged and/or personal injury arising from improper installation of the HWG module.

⚠ CAUTION! ⚠

CAUTION! The HWG module must be installed in an area that is not subject to freezing temperatures.

⚠ CAUTION! ⚠

CAUTION! Locate Refrigerant lines to avoid accidental damage by lawnmowers or children.

NOTICE! Make sure the compressor discharge line is connected to the “Hot Gas In” stub on the Heat Recovery Unit.

ELECTRICAL - LINE VOLTAGE

⚠ WARNING! ⚠

WARNING! To avoid possible injury or death due to electrical shock, open the power supply disconnect switch and secure it in an open position during installation.

Electrical - Line Voltage

All field installed wiring, including electrical ground, must comply with the National Electrical Code as well as all applicable local codes. Refer to the unit electrical data for fuse sizes. Consult wiring diagram for field connections that must be made by the installing (or electrical) contractor.

⚠ CAUTION! ⚠

CAUTION! Use only copper conductors for field installed electrical wiring. Unit terminals are not designed to accept other types of conductors.

All final electrical connections must be made with a length of flexible conduit to minimize vibration and sound transmission to the building.

ELECTRICAL - LINE VOLTAGE

Table 8a: GT-PX Split (50YDS) Series Electrical Data

Model	Compressor			HWG Pump FLA	External Pump FLA	Total Unit FLA	Min Circuit Amps	Max Fuse/HACR	Min AWG	Max Wire Ft. (m)
	RLA	LRA	Qty							
026	10.3	52.0	1	0.4	4.0	14.7	17.3	25	10	107 (32.7)
038	16.7	82.0	1	0.4	4.0	21.1	25.3	40	10	73 (22.3)
049	21.2	96.0	1	0.4	4.0	25.6	30.9	50	8	95 (29.2)
064	25.6	118.0	1	0.4	4.0	30.0	36.4	60	8	81 (24.8)

Rated Voltage of 208/230/60/1
HACR circuit breaker in USA only

Wire length based on one way measurement with 2% voltage drop

Min/Max Voltage of 197/254
All fuses Class RK-5

Wire size based on 60°C copper conductor and Minimum Circuit Ampacity.

Table 8b: GT-G Split (50YCS) Series Electrical Data

Model	Compressor			HWG Pump FLA	External Pump FLA	Total Unit FLA	Min Circuit Amps	Max Fuse/HACR	Min AWG	Max Wire Ft. (m)
	RLA	LRA	Qty							
018	8.6	40.3	1	0.40	4.0	13.0	15.2	20	12	76 (23.3)
024	10.3	56.0	1	0.40	4.0	14.7	17.3	25	10	107 (32.7)
030	12.2	67.0	1	0.40	4.0	16.6	19.7	30	10	94 (28.7)
036	13.5	73.0	1	0.40	4.0	17.9	21.3	35	10	87 (26.5)
042	16.5	95.0	1	0.40	4.0	20.9	25.0	40	10	74 (22.6)
048	18.3	109.0	1	0.40	4.0	22.7	27.3	45	10	67 (20.7)
060	25.0	148.0	1	0.40	4.0	29.4	35.7	60	8	82 (25.2)

Rated Voltage of 208/230/60/1
HACR circuit breaker in USA only

Wire length based on one way measurement with 2% voltage drop

Min/Max Voltage of 197/254
All fuses Class RK-5

Wire size based on 60°C copper conductor and Minimum Circuit Ampacity.

Table 8c: GT-S Split (38WQS) Series Electrical Data

Model	Compressor				HWG Pump FLA	Ext Loop Pump FLA	Total Unit FLA	Min Circuit Amps	Max Fuse/HACR	Min AWG	Max Wire Ft. (m)
	RLA	LRA	Qty	Crank-case							
018	7.1	38.0	1	N/A	0.40	4.0	11.5	13.3	20	12	87 (26.6)
024	10.3	56.0	1	0.17	0.40	4.0	14.9	17.4	25	10	106 (32.5)
030	12.2	67.0	1	0.17	0.40	4.0	16.8	19.8	30	10	93 (28.6)
036	13.5	73.0	1	0.17	0.40	4.0	18.1	21.4	30	10	86 (26.4)
042	16.5	95.0	1	0.17	0.40	4.0	21.1	25.2	40	10	73 (22.4)
048	18.3	109.0	1	0.17	0.40	4.0	22.9	27.4	45	10	67 (20.6)
060	25.0	148.0	1	0.29	0.40	4.0	29.7	35.9	60	8	82 (25.1)

Rated Voltage of 208-230/60/1
HACR circuit breaker in USA only

Wire length based on one way measurement with 2% voltage drop

Min/Max Voltage of 197/254
All fuses Class RK-5

Wire size based on 60°C copper conductor and Minimum Circuit Ampacity.

ELECTRICAL - POWER WIRING

Electrical - Line Voltage

All field installed wiring, including electrical ground, must comply with the National Electrical Code as well as all applicable local codes. Refer to the unit electrical data for fuse sizes. Consult wiring diagram for field connections that must be made by the installing (or electrical) contractor.

All final electrical connections must be made with a length of flexible conduit to minimize vibration and sound transmission to the building.

General Line Voltage Wiring

Be sure the available power is the same voltage and phase shown on the unit serial plate. Line and low voltage wiring must be done in accordance with local codes or the National Electric Code, whichever is applicable.

Power Connection

Line voltage connection is made by connecting the incoming line voltage wires to the “L” side of the contactor as shown in Figures 21a through 21c. Consult Tables 8a through 8c for correct fuse size.

Figure 21c: R-22 Outdoor Compressor Section Line Voltage Field Wiring

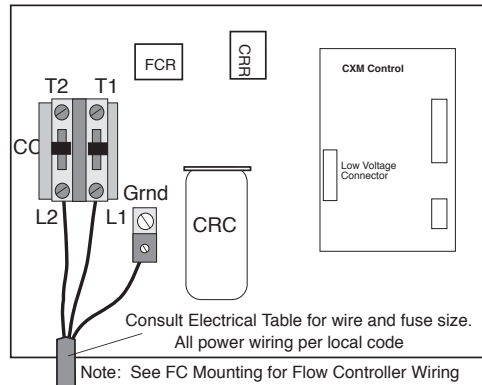

208-230 Volt Operation

Verify transformer tap with air handler wiring diagram to insure that the transformer tap is set to the correct voltage, 208V or 230V.

Figure 21a: R-410A Compressor Section Line Voltage Field Wiring

Unit Power Supply
(see electrical table for wire and breaker size)

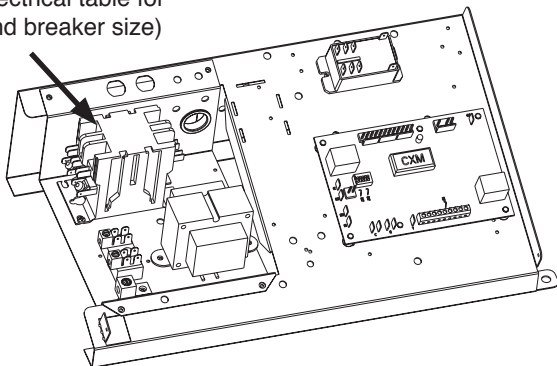

ELECTRICAL - HWG WIRING

HWG Wiring - “Indoor” Compressor Section

The hot water generator pump power wiring is disabled at the factory to prevent operating the HWG pump “dry.” After all HWG piping is completed and air purged from the water piping, the pump power wires should be applied to terminals on the HWG power block PB2 as shown in the unit wiring diagram. This connection can also serve as a HWG disable when servicing the unit.

HWG Wiring - “Outdoor” Compressor Section

The HWG module should be wired to the outdoor section pump controls (see Figure 20). A safety disconnect should be installed at the HWG module to allow servicing of the module. If wired as shown, any time the compressor is energized, the HWG module pump will be activated, which will circulate water from the water heater tank to the HWG module. DO NOT energize the pump until all HWG piping is completed and air is purged from the water piping to avoid running the pump “dry.”

Figure 21b: R-22 Indoor Compressor Section Line Voltage Field Wiring

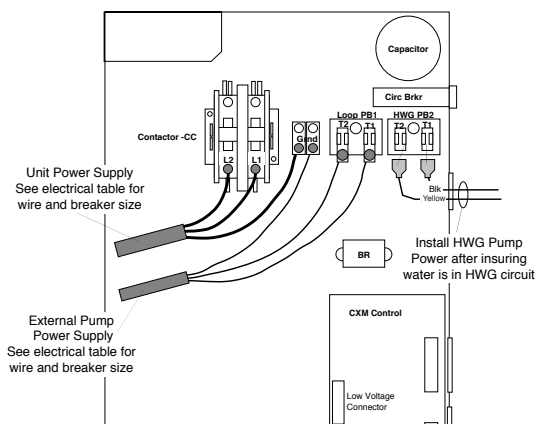

ELECTRICAL - LOW VOLTAGE WIRING

Thermostat Connections

The thermostat should be wired directly to the CXM board. Figures 22a through 22c show low voltage wiring. Note that the air handler or furnace transformer will be used to power the CXM board in the compressor section. See "Electrical – Thermostat" for specific terminal connections.

Figure 22a: 50YDS Low Voltage Field Wiring

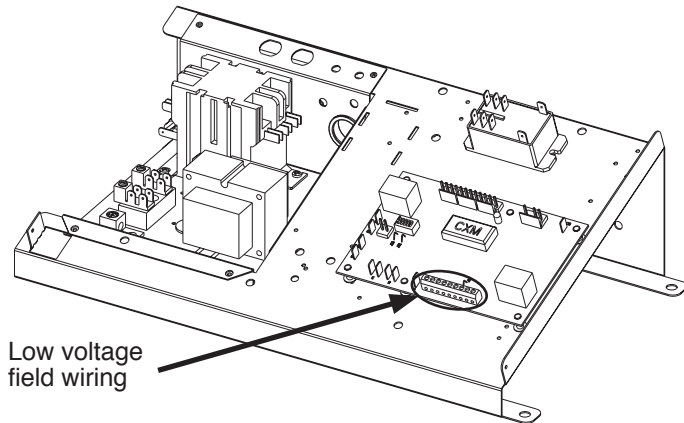

Figure 22b: 50YCS Low Voltage Field Wiring

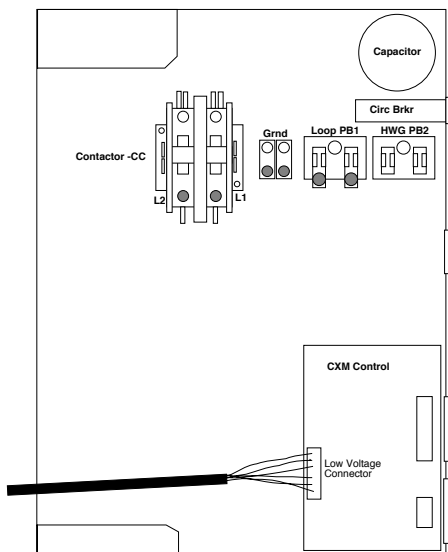
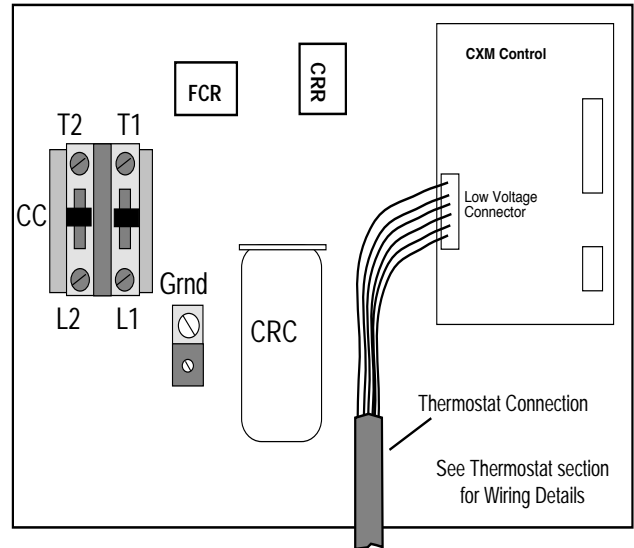

Figure 22c: 38WQS Low Voltage Field Wiring



Low Water Temperature Cutout Selection

The CXM control allows the field selection of low water (or water-antifreeze solution) temperature limit by clipping jumper JW3, which changes the sensing temperature associated with thermistor FP1. Note that the FP1 thermistor is located on the refrigerant line between the coaxial heat exchanger and expansion device (TXV). Therefore, FP1 is sensing refrigerant temperature, not water temperature, which is a better indication of how water flow rate/temperature is affecting the refrigeration circuit.

The factory setting for FP1 is for systems using water (30°F [-1.1°C] refrigerant temperature). In low water temperature (extended range) applications with antifreeze (most ground loops), jumper JW3 should be clipped as shown in Figure 23 to change the setting to 10°F [-12.2°C] refrigerant temperature, a more suitable temperature when using an antifreeze solution. All residential units include water/refrigerant circuit insulation to prevent internal condensation, which is required when operating with entering water temperatures below 59°F [15°C].

Figure 23: FP1 Limit Setting

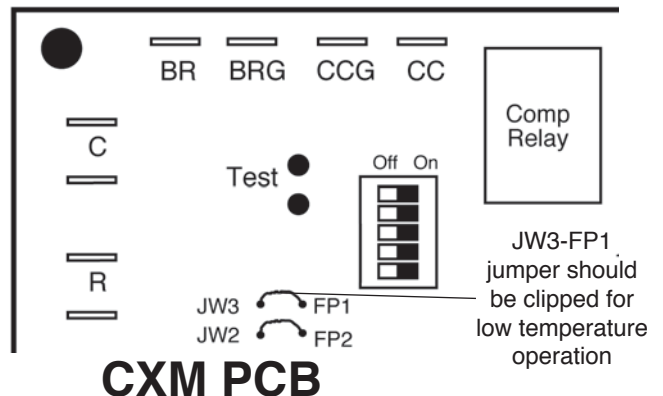

ELECTRICAL - LOW VOLTAGE WIRING

Accessory Connections

A terminal paralleling the compressor contactor coil has been provided on the CXM control. Terminal “A” is designed to control accessory devices, such as water valves. Note: This terminal should be used only with 24 Volt signals and not line voltage. Terminal “A” is energized with the compressor contactor. See Figure 24 or the specific unit wiring diagram for details.

Figure 24: Accessory Wiring

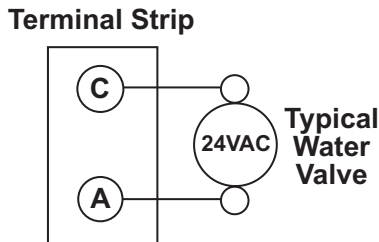

Water Solenoid Valves - “Indoor” Compressor Section Only

An external solenoid valve(s) should be used on ground water installations to shut off flow to the unit when the compressor is not operating. A slow closing valve may be required to help reduce water hammer. Figure 24 shows typical wiring for a 24VAC external solenoid valve. Figures 25 and 26 illustrate typical slow closing water control valve wiring for Taco 500 series (ClimateMaster P/N AVM...) and Taco ESP series valves. Slow closing valves take approximately 60 seconds to open (very little water will flow before 45 seconds). Once fully open, an end switch allows the compressor to be energized. Only relay or triac based electronic thermostats should be used with slow closing valves. When wired as shown, the slow closing valve will operate properly with the following notations:

1. The valve will remain open during a unit lockout.
2. The valve will draw approximately 25-35 VA through the “Y” signal of the thermostat.

Note: This valve can overheat the anticipator of an electromechanical thermostat. Therefore, only relay or triac based thermostats should be used.

Two-stage Units

Two-stage units should be designed with two parallel valves for ground water applications to limit water use during first stage operation. For example, at 1.5 gpm/ton [2.0 l/m per kW], a model 049 unit requires 6 gpm [23 l/m] for full load (2nd stage) operation, but only 4 gpm [15 l/m] during 1st stage operation. Since the unit will operate on first stage 80-90% of the time, significant water savings can be realized by using two parallel solenoid valves with two flow regulators. In the example above, stage one solenoid would be installed with a 4 gpm [15 l/m] flow regulator on the outlet, while stage two would utilize a 2

gpm [8 l/m] flow regulator. When stage one is operating, the second solenoid valve will be closed. When stage two is operating, both valves will be open, allowing full load flow rate.

Figure 27 illustrates piping for two-stage solenoid valves. Review figures 24-26 for wiring of stage one valve. Stage two valve should be wired between “Y2” (compressor solenoid -- wire nut connection) and terminal “C.” NOTE: When EWT is below 50°F [10°C], 2 gpm per ton (2.6 l/m per kW) is required.

Figure 25: AVM Valve Wiring

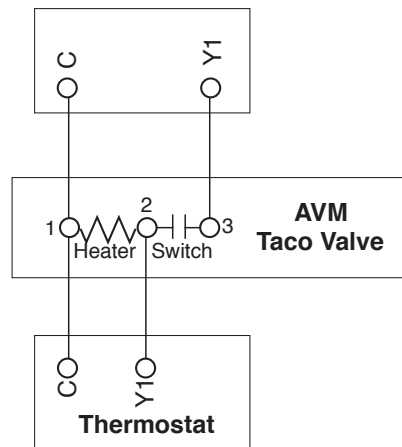

Figure 26: Taco ESP Valve Wiring

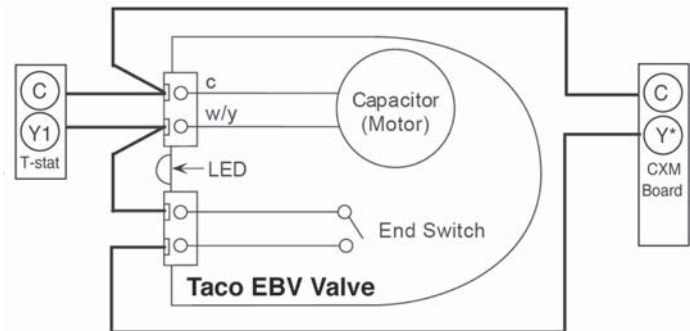
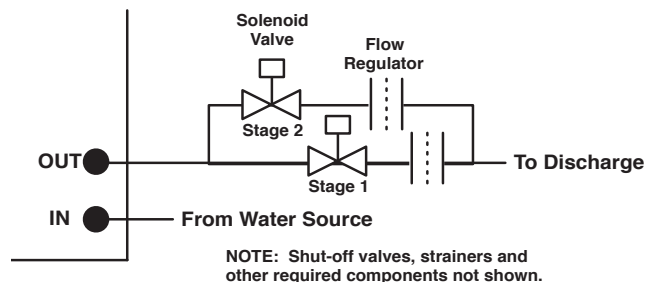

Figure 27: Two-Stage Piping



⚠ CAUTION! ⚠

CAUTION! Many units installed with a factory or field supplied manual or electric shut-off valve. **DAMAGE WILL OCCUR** if shut-off valve is **closed** during unit operation. A high pressure switch must be installed on the heat pump side of any field provided shut-off valves and connected to the heat pump controls in series with the built-in refrigerant circuit high pressure switch to disable compressor operation if water pressure exceeds pressure switch setting. The field installed high pressure switch shall have a cut-out pressure of 235 psig and a cut-in pressure of 190 psig. This pressure switch can be ordered from ClimateMaster with a 1/4" internal flare connection as part number 39B0005N01.

ELECTRICAL - THERMOSTAT WIRING

Thermostat Installation

The thermostat should be located on an interior wall in a larger room, away from supply duct drafts. **DO NOT** locate the thermostat in areas subject to sunlight, drafts or on external walls. The wire access hole behind the thermostat may in certain cases need to be sealed to prevent erroneous temperature measurement. Position the thermostat back plate against the wall so that it appears level and so the thermostat wires protrude

through the middle of the back plate. Mark the position of the back plate mounting holes and drill holes with a 3/16" (5mm) bit. Install supplied anchors and secure plate to the wall. Thermostat wire must be 18 AWG wire. Wire the appropriate thermostat as shown in Figures 28a through 28c to the low voltage terminal strip on the CXM control board. Practically any heat pump thermostat will work with these units, provided it has the correct number of heating and cooling stages.

Figure 28b: Typical Thermostat Wiring, Single-Stage Units (2 Heat / 1 Cool)

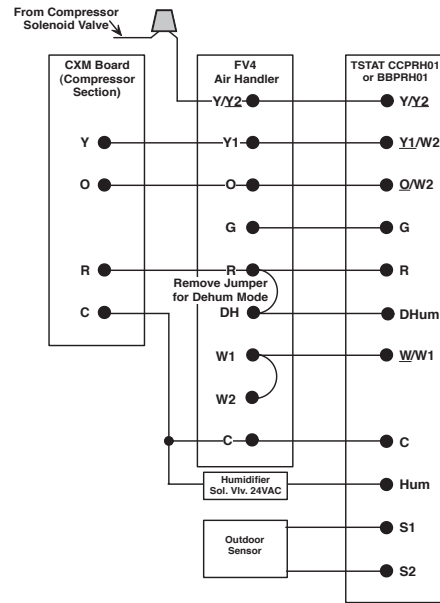

- Notes:
1. Thermostat DIP switches must be configured for two-speed heat pump.
 2. Compressor 2nd stage connection is not part of the terminal strip on the CXM board. A wire nut connection is required between the compressor solenoid valve and Y/Y2 connection at the fan coil.

Figure 28a: Typical Thermostat Wiring, Two-Stage Units (3 Heat / 2 Cool)

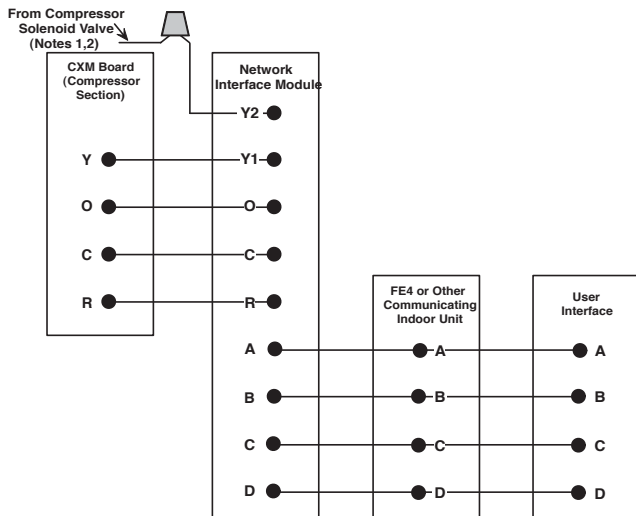

- Notes:
1. Compressor 2nd stage connection is not part of the terminal strip on the CXM board. A wire nut connection is required between the compressor solenoid valve and N.I.M.
 2. Y2 connection on N.I.M. is not used for single stage units.
 3. Do not connect W from the CXM board to the N.I.M.

Figure 28b: Typical Thermostat Wiring, Infinity / Evolution Controls

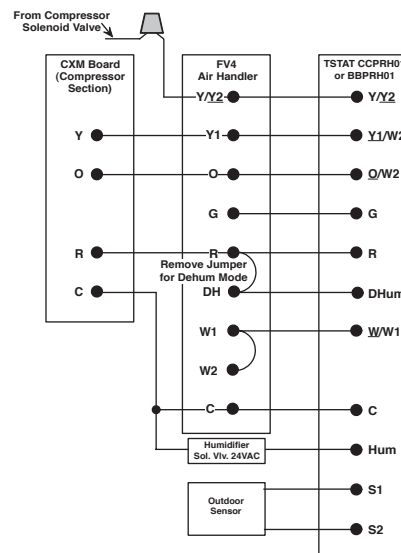

- Notes:
1. Thermostat DIP switches must be configured for two-speed heat pump.
 2. Compressor 2nd stage connection is not part of the terminal strip on the CXM board. A wire nut connection is required between the compressor solenoid valve and Y/Y2 connection at the fan coil.

TYPICAL WIRING DIAGRAM - 50YCS UNITS WITH CXM BOARD

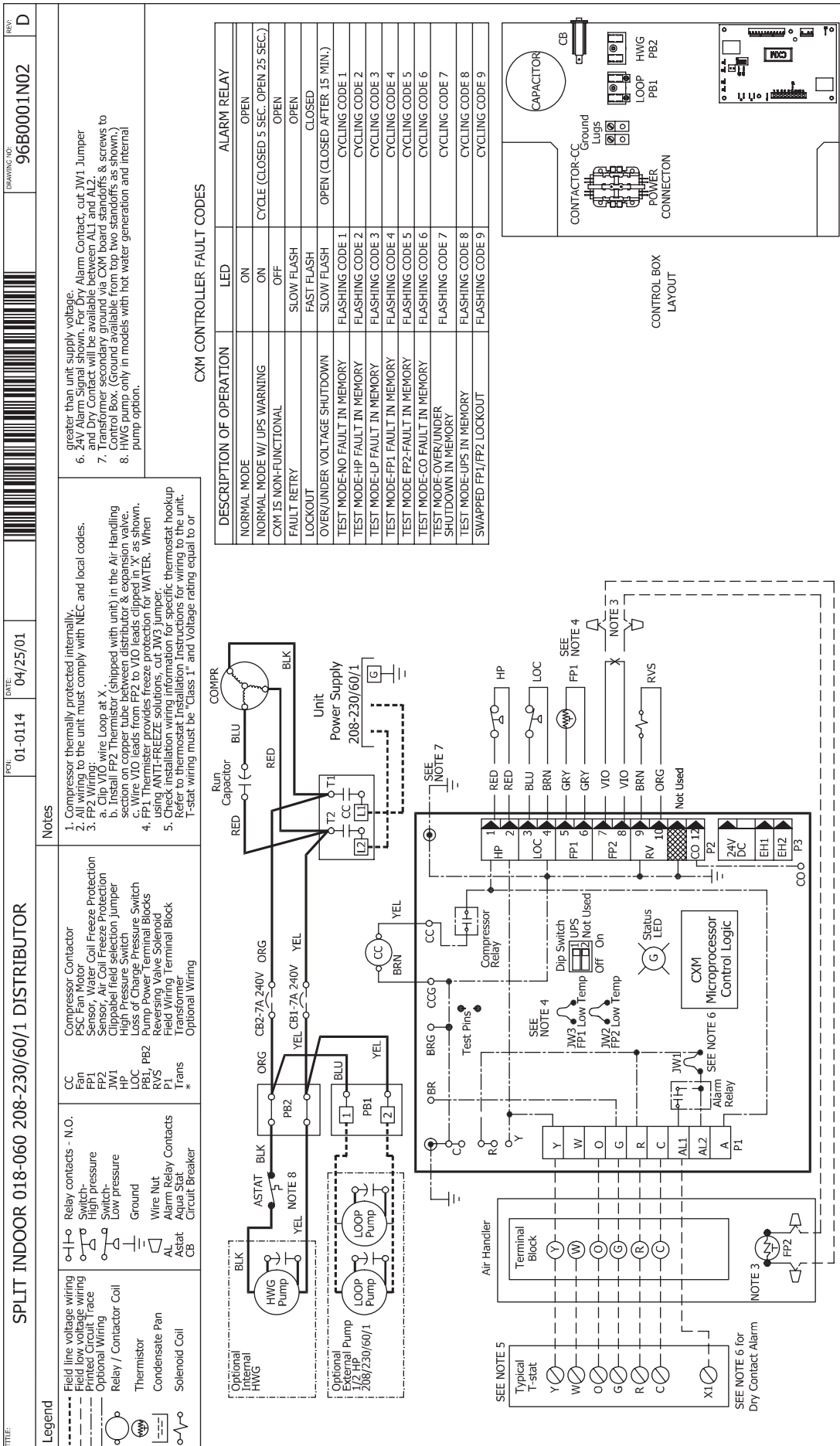

CXM CONTROLS

CXM Control

For detailed control information, see CXM/DXM Application, Operation and Maintenance (AOM) manual (part #97B0003N08).

Field Selectable Inputs

Test mode: Test mode allows the service technician to check the operation of the control in a timely manner. By momentarily shorting the test terminals, the CXM control enters a 20 minute test mode period in which all time delays are sped up 15 times. Upon entering test mode, the status LED will flash a code representing the last fault. For diagnostic ease at the thermostat, the alarm relay will also cycle during test mode. The alarm relay will cycle on and off similar to the status LED to indicate a code representing the last fault, at the thermostat. Test mode can be exited by shorting the test terminals for 3 seconds.

Retry Mode: If the control is attempting a retry of a fault, the status LED will slow flash (slow flash = one flash every 2 seconds) to indicate the control is in the process of retrying.

Field Configuration Options

Note: In the following field configuration options, jumper wires should be clipped **ONLY** when power is removed from the CXM control.

Water coil low temperature limit setting: Jumper 3 (JW3-FP1 Low Temp) provides field selection of temperature limit setting for FP1 of 30°F or 10°F [-1°F or -12°C] (refrigerant temperature).

Not Clipped = 30°F [-1°C]. Clipped = 10°F [-12°C].

Air coil low temperature limit setting: Jumper 2 (JW2-FP2 Low Temp) provides field selection of temperature limit setting for FP2 of 30°F or 10°F [-1°F or -12°C] (refrigerant temperature). Note: This jumper should only be clipped under extenuating circumstances, as recommended by the factory.

Not Clipped = 30°F [-1°C]. Clipped = 10°F [-12°C].

Alarm relay setting: Jumper 1 (JW1-AL2 Dry) provides field selection of the alarm relay terminal AL2 to be jumpered to 24VAC or to be a dry contact (no connection). *Not Clipped = AL2 connected to R. Clipped = AL2 dry contact (no connection).*

DIP Switches

Note: In the following field configuration options, DIP switches should only be changed when power is removed from the CXM control.

DIP switch 1: Unit Performance Sentinel Disable - provides field selection to disable the UPS feature. *On = Enabled. Off = Disabled.*

DIP switch 2: Stage 2 Selection - provides selection of whether compressor has an “on” delay. If set to stage 2, the compressor will have a 3 second delay before energizing. Also, if set for stage 2, the alarm relay will NOT cycle during test mode.

On = Stage 1. Off = Stage 2

DIP switch 3: Not Used.

DIP switch 4: DDC Output at EH2 - provides selection for DDC operation. If set to “DDC Output at EH2,” the EH2 terminal will continuously output the last fault code of the controller. If set to “EH2 normal,” EH2 will operate as standard electric heat output.

On = EH2 Normal. Off = DDC Output at EH2.

NOTE: Some CXM controls only have a 2 position DIP switch package. If this is the case, this option can be selected by clipping the jumper which is in position 4 of SW1.

Jumper not clipped = EH2 Normal. Jumper clipped = DDC Output at EH2.

DIP switch 5: Factory Setting - Normal position is “On.” Do not change selection unless instructed to do so by the factory.

Table 9a: CXM LED And Alarm Relay Operations

Description of Operation	LED	Alarm Relay
Normal Mode	On	Open
Normal Mode with UPS Warning	On	Cycle (closed 5 sec., Open 25 sec.)
CXM is non-functional	Off	Open
Fault Retry	Slow Flash	Open
Lockout	Fast Flash	Closed
Over/Under Voltage Shutdown	Slow Flash	Open (Closed after 15 minutes)
Test Mode - No fault in memory	Flashing Code 1	Cycling Code 1
Test Mode - HP Fault in memory	Flashing Code 2	Cycling Code 2
Test Mode - LP Fault in memory	Flashing Code 3	Cycling Code 3
Test Mode - FP1 Fault in memory	Flashing Code 4	Cycling Code 4
Test Mode - FP2 Fault in memory	Flashing Code 5	Cycling Code 5
Test Mode - CO Fault in memory	Flashing Code 6	Cycling Code 6
Test Mode - Over/Under shutdown in memory	Flashing Code 7	Cycling Code 7
Test Mode - UPS in memory	Flashing Code 8	Cycling Code 8
Test Mode - Swapped Thermistor	Flashing Code 9	Cycling Code 9

-Slow Flash = 1 flash every 2 seconds

-Fast Flash = 2 flashes every 1 second

-Flash code 2 = 2 quick flashes, 10 second pause, 2 quick flashes, 10 second pause, etc.

-On pulse 1/3 second; off pulse 1/3 second

CXM CONTROLS

Safety Features – CXM Control

The safety features below are provided to protect the compressor, heat exchangers, wiring and other components from damage caused by operation outside of design conditions.

Anti-short cycle protection: The control features a 5 minute anti-short cycle protection for the compressor.

Note: The 5 minute anti-short cycle also occurs at power up.

Random start: The control features a random start upon power up of 5-80 seconds.

Fault Retry: In Fault Retry mode, the Status LED begins slowly flashing to signal that the control is trying to recover from a fault input. The control will stage off the outputs and then “try again” to satisfy the thermostat input call. Once the thermostat input call is satisfied, the control will continue on as if no fault occurred. If 3 consecutive faults occur without satisfying the thermostat input call, the control will go into “lockout” mode. The last fault causing the lockout will be stored in memory and can be viewed by going into test mode. Note: FP1/FP2 faults are factory set at only one try.

Lockout: In lockout mode, the status LED will begin fast flashing. The compressor relay is turned off immediately. Lockout mode can be “soft” reset by turning off the thermostat (or satisfying the call). A “soft” reset keeps the fault in memory but resets the control. A “hard” reset (disconnecting power to the control) resets the control and erases fault memory.

Lockout with emergency heat: While in lockout mode, if W becomes active (CXM), emergency heat mode will occur.

High pressure switch: When the high pressure switch opens due to high refrigerant pressures, the compressor relay is de-energized immediately since the high pressure switch is in series with the compressor contactor coil. The high pressure fault recognition is immediate (does not delay for 30 continuous seconds before de-energizing the compressor).

High pressure lockout code = 2

Example: 2 quick flashes, 10 sec pause, 2 quick flashes, 10 sec. pause, etc.

Low pressure switch: The low pressure switch must be open and remain open for 30 continuous seconds during “on” cycle to be recognized as a low pressure fault. If the low pressure switch is open for 30 seconds prior to compressor power up it will be considered a low pressure (loss of charge) fault. The low pressure switch input is bypassed for the initial 60 seconds of a compressor run cycle.

Low pressure lockout code = 3

Water coil low temperature (FP1): The FP1 thermistor temperature must be below the selected low temperature limit setting for 30 continuous seconds during a compressor run cycle to be recognized as a FP1 fault. The FP1 input is bypassed for the initial 60 seconds of a compressor run cycle. FP1 is set at the factory for one try. Therefore, the control will go into lockout mode once the FP1 fault has occurred.

FP1 lockout code = 4

Air coil low temperature (FP2): The FP2 thermistor temperature must be below the selected low temperature limit setting for 30 continuous seconds during a

compressor run cycle to be recognized as a FP2 fault.

The FP2 input is bypassed for the initial 60 seconds of a compressor run cycle. FP2 is set at the factory for one try. Therefore, the control will go into lockout mode once the FP2 fault has occurred.

FP2 lockout code = 5

Condensate overflow: The condensate overflow sensor must sense overflow level for 30 continuous seconds to be recognized as a CO fault. Condensate overflow will be monitored at all times.

CO lockout code = 6

Over/under voltage shutdown: An over/under voltage condition exists when the control voltage is outside the range of 19VAC to 30VAC. Over/under voltage shutdown is a self-resetting safety. If the voltage comes back within range for at least 0.5 seconds, normal operation is restored. This is not considered a fault or lockout. If the CXM is in over/under voltage shutdown for 15 minutes, the alarm relay will close.

Over/under voltage shut down code = 7

Unit Performance Sentinel-UPS (patent pending): The UPS feature indicates when the heat pump is operating inefficiently. A UPS condition exists when:

- In heating mode with compressor energized, FP2 is greater than 125°F [52°C] for 30 continuous seconds, or:
- In cooling mode with compressor energized, FP1 is greater than 125°F [52°C] for 30 continuous seconds, or:
- In cooling mode with compressor energized, FP2 is less than 40°F [4.5°C] for 30 continuous seconds. If a UPS condition occurs, the control will immediately go to UPS warning. The status LED will remain on as if the control is in normal mode. Outputs of the control, excluding LED and alarm relay, will NOT be affected by UPS. The UPS condition cannot occur during a compressor off cycle. During UPS warning, the alarm relay will cycle on and off. The cycle rate will be “on” for 5 seconds, “off” for 25 seconds, “on” for 5 seconds, “off” for 25 seconds, etc.

UPS warning code = 8

Swapped FP1/FP2 thermistors: During test mode, the control monitors to see if the FP1 and FP2 thermistors are in the appropriate places. If the control is in test mode, the control will lockout, with code 9, after 30 seconds if:

- The compressor is on in the cooling mode and the FP1 sensor is colder than the FP2 sensor, or:
- The compressor is on in the heating mode and the FP2 sensor is colder than the FP1 sensor.

Swapped FP1/FP2 thermistor code = 9.

Diagnostic Features

The LED on the CXM board advises the technician of the current status of the CXM control. The LED can display either the current CXM mode or the last fault in memory if in test mode. If there is no fault in memory, the LED will flash Code 1 (when in test mode).

CXM CONTROLS

CXM Control Start-up Operation

The control will not operate until all inputs and safety controls are checked for normal conditions. The compressor will have a 5 minute anti-short cycle delay at power-up. The first time after power-up that there is a call for compressor, the compressor will follow a 5 to 80 second random start delay. After the random start delay and anti-short cycle delay, the compressor relay will be energized. On all subsequent compressor calls, the random start delay is omitted.

Table 9b: Unit Operation

T-stat signal	50YDS	50YCS/38WQS	50YCS/38WQS
	Variable Speed Air Handler	Variable Speed Air Handler	PSC Air Handler
G	Fan only	Fan only	Fan only
G, Y or Y1	Stage 1 heating ¹	Stage 1 heating ³	Stage 1 heating ⁵
G, Y1, Y2	Stage 2 heating ¹	Stage 2 heating ³	Stage 2 heating ⁵
G, Y1, Y2, W	Stage 3 heating ¹	Stage 3 heating ³	N/A
G, W	Emergency heat	Emergency heat	Emergency heat
G, Y or Y1, O	Stage 1 cooling ²	Stage 1 cooling ⁴	Cooling ⁶
G, Y1, Y2, O	Stage 2 cooling ²	Stage 2 cooling ⁴	N/A

- 1 Stage 1 = 1st stage compressor, 1st stage fan operation
 Stage 2 = 2nd stage compressor, 2nd stage fan operation
 Stage 3 = 2nd stage compressor, auxiliary electric heat, 2nd or 3rd stage fan operation (depending on fan settings)
- 2 Stage 1 = 1st stage compressor, 1st stage fan operation, reversing valve
 Stage 2 = 2nd stage compressor, 2nd stage fan operation, reversing valve
- 3 Stage 1 = compressor, 1st stage fan operation
 Stage 2 = compressor, 2nd stage fan operation
 Stage 3 = compressor, auxiliary electric heat, 2nd or 3rd stage fan operation (depending on fan settings)
- 4 Stage 1 = compressor, 1st stage fan operation, reversing valve
 Stage 2 = compressor, 2nd stage fan operation, reversing valve
- 5 Stage 1 = compressor, fan
 Stage 2 = compressor, auxiliary electric heat, fan
- 6 Cooling = compressor, fan, reversing valve

CXM CONTROLS

Table 10: Nominal resistance at various temperatures

Temp (°C)	Temp (°F)	Resistance (kOhm)	Temp (°C)	Temp (°F)	Resistance (kOhm)
-17.8	0.0	85.41	55	131.0	2.99
-17.5	0.5	84.16	56	132.8	2.88
-16.9	1.5	81.43	57	134.6	2.77
-12	10.4	61.70	58	136.4	2.67
-11	12.2	58.40	59	138.2	2.58
-10	14.0	55.30	60	140.0	2.49
-9	15.8	52.40	61	141.8	2.40
-8	17.6	49.60	62	143.6	2.32
-7	19.4	47.00	63	145.4	2.23
-6	21.2	44.60	64	147.2	2.16
-5	23.0	42.30	65	149.0	2.08
-4	24.8	40.10	66	150.8	2.01
-3	26.6	38.10	67	152.6	1.94
-2	28.4	36.10	68	154.4	1.88
-1	30.2	34.30	69	156.2	1.81
0	32.0	32.60	70	158.0	1.75
1	33.8	31.00	71	159.8	1.69
2	35.6	29.40	72	161.6	1.64
3	37.4	28.00	73	163.4	1.58
4	39.2	26.60	74	165.2	1.53
5	41.0	25.30	75	167.0	1.48
6	42.8	24.10	76	168.8	1.43
7	44.6	23.00	77	170.6	1.38
8	46.4	21.90	78	172.4	1.34
9	48.2	20.80	79	174.2	1.30
10	50.0	19.90	80	176.0	1.26
11	51.8	18.97	81	177.8	1.22
12	53.6	18.09	82	179.6	1.18
13	55.4	17.25	83	181.4	1.14
14	57.2	16.46	84	183.2	1.10
15	59.0	15.71	85	185.0	1.07
16	60.8	15.00	86	186.8	1.04
17	62.6	14.32	87	188.6	1.00
18	64.4	13.68	88	190.4	0.97
19	66.2	13.07	89	192.2	0.94
20	68.0	12.49	90	194.0	0.92
21	69.8	11.94	91	195.8	0.89
22	71.6	11.42	92	197.6	0.86
23	73.4	10.92	93	199.4	0.84
24	75.2	10.45	94	201.2	0.81
25	77.0	10.00	95	203.0	0.79
26	78.8	9.57	96	204.8	0.76
27	80.6	9.17	97	206.6	0.74
28	82.4	8.78	98	208.4	0.72
29	84.2	8.41	99	210.2	0.70
30	86.0	8.06	100	212.0	0.68
31	87.8	7.72	101	213.8	0.66
32	89.6	7.40	102	215.6	0.64
33	91.4	7.10	103	217.4	0.62
34	93.2	6.81	104	219.2	0.60
35	95.0	6.53	105	221.0	0.59
36	96.8	6.27	106	222.8	0.57
37	98.6	6.02	107	224.6	0.56
38	100.4	5.78	108	226.4	0.54
39	102.2	5.55	109	228.2	0.53
40	104.0	5.33	110	230.0	0.51
41	105.8	5.12	111	231.8	0.50
42	107.6	4.92	112	233.6	0.48
43	109.4	4.73	113	235.4	0.47
44	111.2	4.54	114	237.2	0.46
45	113.0	4.37	115	239.0	0.45
46	114.8	4.20	116	240.8	0.43
47	116.6	4.04	117	242.6	0.42
48	118.4	3.89	118	244.4	0.41
49	120.2	3.74	119	246.2	0.40
50	122.0	3.60	120	248.0	0.39
51	123.8	3.47	121	249.8	0.38
52	125.6	3.34	122	251.6	0.37
53	127.4	3.22	123	253.4	0.36
54	129.2	3.10			

Rev.: 5/23/00 m

CXM Thermostat Details

Thermostat Compatibility - Most all heat pump thermostats can be used with the CXM control. **However Heat/Cool stats are NOT compatible with the CXM.**

Anticipation Leakage Current - Maximum leakage current for "Y" is 50 mA and for "W" is 20mA. Triacs can be used if leakage current is less than above. Thermostats with anticipators can be used if anticipation current is less than that specified above.

Thermostat Signals -

- "Y" and "W" have a 1 second recognition time when being activated or being removed.
- "O" and "G" are direct pass through signals but are monitored by the micro processor.
- "R" and "C" are from the transformer.
- "AL1" and "AL2" originate from the alarm relay.
- "A" is paralleled with the compressor output for use with well water solenoid valves.
- The "Y" 1/4" quick connect is a connection point to the "Y" input terminal P1 for factory use. This "Y" terminal can be used to drive panel mounted relays such as the loop pump relay.

UNIT STARTING AND OPERATING CONDITIONS

Operating Limits

Environment – “Indoor” compressor section is designed for indoor installation only. Never install “indoor” compressor section in areas subject to freezing or where humidity levels could cause cabinet condensation (such as unconditioned spaces subject to 100% outside air). “Outdoor” unit is designed for conditions where ambient air is below freezing (see Table 11).

Power Supply – A voltage variation of +/- 10% of nameplate utilization voltage is acceptable.

Starting Conditions

Consult Table 11 for the particular model number.

Starting conditions vary depending upon model number and are based upon the following notes:

Notes:

1. Conditions in Table 11 are not normal or continuous operating conditions. Minimum/maximum limits are

start-up conditions to bring the building space up to occupancy temperatures. Units are not designed to operate under these conditions on a regular basis.

2. Voltage utilization range complies with ARI Standard 110.

Determination of operating limits is dependent primarily upon three factors: 1) return air temperature. 2) water temperature, and 3) ambient temperature. When any one of these factors is at minimum or maximum levels, the other two factors should be at normal levels to insure proper unit operation.

Extreme variations in temperature and humidity and/or corrosive water or air will adversely affect unit performance, reliability, and service life.

Table 11: Unit Operation

Operating Limits	50YDS/50YCS		38WQS	
	Cooling	Heating	Cooling	Heating
Air Limits				
Min. ambient air, DB	45°F [7°C]	39°F [4°C]	-10°F [-23°C]	-10°F [-23°C]
Rated ambient air, DB	80.6°F [27°C]	68°F [20°C]	80.6°F [27°C]	68°F [20°C]
Max. ambient air, DB	110°F [43°C]	85°F [29°C]	110°F [43°C]	85°F [29°C]
Min. entering air, DB/WB	50°F [10°C]	40°F [4.5°C]	50°F [10°C]	50°F [10°C]
Rated entering air, DB/WB	80.6/66.2°F [27/19°C]	68°F [20°C]	80.6/66.2°F [27/19°C]	68°F [20°C]
Max. entering air, DB/WB	110/83°F [43/28°C]	80°F [27°C]	110/83°F [43/28°C]	80°F [27°C]
Water Limits				
Min. entering water	30°F [-1°C]	20°F [-6.7°C]	30°F [-1°C]	20°F [-6.7°C]
Normal entering water	50-110°F [10-43°C]	30-70°F [-1 to 21°C]	50-110°F [10-43°C]	30-70°F [-1 to 21°C]
Max. entering water	120°F [49°C]	90°F [32°C]	120°F [49°C]	90°F [32°C]
Normal water flow	1.5 to 3.0 gpm/ton		1.5 to 3.0 gpm/ton	
	2.0 to 3.9 l/m per kW		2.0 to 3.9 l/m per kW	

UNIT STARTING AND OPERATING CONDITIONS

Unit and System Checkout

BEFORE POWERING SYSTEM, please check the following:

UNIT CHECKOUT

- Balancing/shutoff valves: Insure that all isolation valves are open and water control valves are wired.
- Line voltage and wiring: Verify that voltage is within an acceptable range for the unit and wiring and fuses/breakers are properly sized. Verify that low voltage wiring is complete.
- Unit control transformer: Insure that transformer has the properly selected voltage tap. Residential 208-230V units are factory wired for 230V operation unless specified otherwise.
- Loop/water piping is complete and purged of air. Water/piping is clean.
- Antifreeze has been added if necessary.
- Entering water and air: Insure that entering water and air temperatures are within operating limits of Table 10.
- Low water temperature cutout: Verify that low water temperature cut-out on the CXM/DXM control is properly set.
- Unit fan: Manually rotate fan to verify free rotation and insure that blower wheel is secured to the motor shaft. Be sure to remove any shipping supports if needed. DO NOT oil motors upon start-up. Fan motors are pre-oiled at the factory. Check unit fan speed selection and compare to design requirements.
- Condensate line: Verify that condensate line is open and properly pitched toward drain.
- HWG pump is disconnected unless piping is completed and air has been purged from the system.
- Water flow balancing: Record inlet and outlet water temperatures for each heat pump upon startup. This check can eliminate nuisance trip outs and high velocity water flow that could erode heat exchangers.
- Unit air coil and filters: Insure that filter is clean and accessible. Clean air coil of all manufacturing oils.
- Unit controls: Verify that CXM field selection options are properly set. Low voltage wiring is complete.
- Blower speed is set.
- Service/access panels are in place.

SYSTEM CHECKOUT

- System water temperature: Check water temperature for proper range and also verify heating and cooling set points for proper operation.
- System pH: Check and adjust water pH if necessary to maintain a level between 6 and 8.5. Proper pH promotes longevity of hoses and fittings (see Table 3).
- System flushing: Verify that all air is purged from the system. Air in the system can cause poor operation or system corrosion. Water used in the system must be potable quality initially and clean of dirt, piping slag, and strong chemical cleaning agents. Some antifreeze solutions may require distilled water.
- Flow Controller pump(s): Verify that the pump(s) is wired and in operating condition.

- System controls: Verify that system controls function and operate in the proper sequence.
- Low water temperature cutout: Verify that low water temperature cut-out controls are set properly (FP1 - JW3).
- Miscellaneous: Note any questionable aspects of the installation.

⚠ CAUTION! ⚠

CAUTION! Verify that ALL water control valves are open and allow water flow prior to engaging the compressor. Freezing of the coax or water lines can permanently damage the heat pump.

NOTICE! Failure to remove shipping brackets from spring-mounted compressors will cause excessive noise, and could cause component failure due to added vibration.

⚠ CAUTION! ⚠

CAUTION! To avoid equipment damage, DO NOT leave system filled in a building without heat during the winter unless antifreeze is added to the water loop. Heat exchangers never fully drain by themselves and will freeze unless winterized with antifreeze.

Unit Start-up Procedure

1. Turn the thermostat fan position to "ON." Blower should start.
2. Balance air flow at registers.
3. Adjust all valves to their full open position. Turn on the line power to all heat pump units.
4. Room temperature should be within the minimum-maximum ranges of Table 11. During start-up checks, loop water temperature entering the heat pump should be between 30°F [-1°C] and 95°F [35°C].
5. Two factors determine the operating limits of water source heat pumps, (a) return air temperature, and (b) water temperature. When any one of these factors is at a minimum or maximum level, the other factor must be at normal level to insure proper unit operation.
 - a. Adjust the unit thermostat to the warmest setting. Place the thermostat mode switch in the "COOL" position. Slowly reduce thermostat setting until the compressor activates.
 - b. Check for cool air delivery at the unit grille within a few minutes after the unit has begun to operate. Note: Units have a five minute time delay in the

UNIT START-UP PROCEDURE

control circuit that can be eliminated on the CXM/DXM control board as shown below in Figure 29. See controls description for details.

- c. Verify that the compressor is on and that the water flow rate is correct by measuring pressure drop through the heat exchanger using the P/T plugs and comparing to Tables 12a through 12b.
 - d. Check the elevation and cleanliness of the condensate lines. Dripping may be a sign of a blocked line. Check that the condensate trap is filled to provide a water seal.
 - e. Refer to Table 12. Check the temperature of both entering and leaving water. If temperature is within range, proceed with the test. If temperature is outside of the operating range, check refrigerant pressures and compare to Tables 14 and 15. Verify correct water flow by comparing unit pressure drop across the heat exchanger versus the data in Tables 12a through 12b. Heat of rejection (HR) can be calculated and compared to catalog data capacity pages. The formula for HR for systems with water is as follows:

$$HR = TD \times GPM \times 500$$
 where TD is the temperature difference between the entering and leaving water, and GPM is the flow rate in U.S. GPM, determined by comparing the pressure drop across the heat exchanger to Tables 12a through 12b.
 - f. Check air temperature drop across the air coil when compressor is operating. Air temperature drop should be between 15°F and 25°F [8°C and 14°C].
 - g. Turn thermostat to "OFF" position. A hissing noise indicates proper functioning of the reversing valve.
6. Allow five (5) minutes between tests for pressure to equalize before beginning heating test.
 - a. Adjust the thermostat to the lowest setting. Place the thermostat mode switch in the "HEAT" position.
 - b. Slowly raise the thermostat to a higher temperature until the compressor activates.
 - c. Check for warm air delivery within a few minutes after the unit has begun to operate.
 - d. Refer to Table 11. Check the temperature of both entering and leaving water. If temperature is within range, proceed with the test. If temperature is outside of the operating range, check refrigerant pressures and compare to Tables 14 and 15. Verify correct water flow by comparing unit pressure drop across the heat exchanger versus the data in Tables 12a through 12b. Heat of extraction (HE) can be calculated and compared to submittal data capacity pages. The formula for HE for systems with water is as follows:

$$HE = TD \times GPM \times 500$$
 where TD is the temperature difference between the entering and leaving water, and GPM is the flow rate in U.S. GPM, determined by comparing the pressure drop across the heat exchanger to Tables 12a through 12b.

- e. Check air temperature rise across the air coil when compressor is operating. Air temperature rise should be between 20°F and 30°F [11°C and 17°C].
 - f. Check for vibration, noise, and water leaks.
7. If unit fails to operate, perform troubleshooting analysis (see troubleshooting section). If the check described fails to reveal the problem and the unit still does not operate, contact a trained service technician to insure proper diagnosis and repair of the equipment.
 8. When testing is complete, set system to maintain desired comfort level.
 9. BE CERTAIN TO FILL OUT AND RETURN ALL WARRANTY REGISTRATION PAPERWORK.

Note: If performance during any mode appears abnormal, refer to the CXM section or troubleshooting section of this manual. To obtain maximum performance, the air coil should be cleaned before start-up. A 10% solution of dishwasher detergent and water is recommended.

▲ WARNING! ▲

WARNING! When the disconnect switch is closed, high voltage is present in some areas of the electrical panel. Exercise caution when working with energized equipment.

▲ CAUTION! ▲

CAUTION! Verify that ALL water control valves are open and allow water flow prior to engaging the compressor. Freezing of the coax or water lines can permanently damage the heat pump.

Figure 29: Test Mode Pins

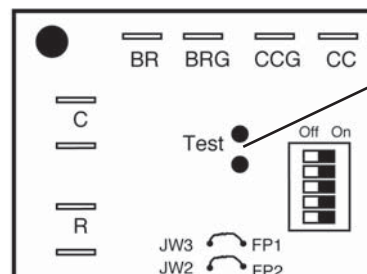

Short test pins together to enter Test Mode and speed-up timing and delays for 20 minutes.

UNIT OPERATING CONDITIONS

Table 12a: Two-Stage R-410A Compressor Section Coax Water Pressure Drop

Model	GPM	Pressure Drop (psi)			
		30°F	50°F	70°F	90°F
026	4.0	1.5	1.3	1.1	1.0
	6.0	3.1	2.6	2.3	2.1
	7.0	4.1	3.4	3.0	2.7
	8.0	5.1	4.3	3.8	3.4
038	4.0	1.2	1.0	0.8	0.6
	6.0	2.6	2.5	2.3	2.1
	8.0	4.5	4.2	4.0	3.7
	9.0	5.7	5.2	4.8	4.4
049	5.5	1.1	0.9	0.8	0.7
	8.3	2.2	2.1	2.0	1.8
	11.0	3.9	3.6	3.2	3.1
	12.0	4.5	4.2	3.8	3.5
064	7.0	0.5	0.3	0.2	0.1
	10.5	1.9	1.8	1.7	1.6
	14.0	3.9	3.5	3.2	2.9
	15.0	4.8	4.3	3.9	3.5

Table 13: Water Temperature Change Through Heat Exchanger

Water Flow, gpm (l/m)	Rise, Cooling °F (°C)	Drop, Heating °F (°C)
For Closed Loop: Ground Source or Closed Loop Systems at 3 gpm per ton (3.9 l/m per kw)	9 - 12 (5 - 6.7)	4 - 8 (2.2 - 4.4)
For Open Loop: Ground Water Systems at 1.5 gpm per ton (2.0 l/m per kw)	20 - 26 (11.1 - 14.4)	10 - 17 (5.6 - 9.4)

Table 12b: R-22 Compressor Section Coax Water Pressure Drop

Model	GPM	Pressure Drop (psi)			
		30°F	50°F	70°F	90°F
018	2	0.6	0.6	0.5	0.5
	4	1.6	1.4	1.3	1.3
	5	2.1	2.0	1.8	1.7
	6	2.8	2.6	2.4	2.3
024	3	0.6	0.6	0.5	0.5
	5	1.3	1.2	1.1	1.1
	6	1.8	1.7	1.5	1.4
	8	2.9	2.7	2.5	2.3
030	4	0.9	0.9	0.8	0.8
	6	1.8	1.7	1.5	1.4
	8	2.9	2.7	2.5	2.3
	10	4.2	3.9	3.6	3.4
036	5	1.6	1.4	1.3	1.3
	7	2.6	2.4	2.3	2.1
	9	3.9	3.7	3.4	3.2
	12	6.4	5.9	5.5	5.2
042	6	2.1	1.9	1.8	1.7
	8	3.2	3.0	2.8	2.6
	11	5.5	5.1	4.7	4.5
	13	7.3	6.8	6.3	5.9
048	6	2.1	1.9	1.8	1.7
	9	3.9	3.7	3.4	3.2
	12	6.4	5.9	5.5	5.2
	15	9.4	8.7	8.1	7.6
060	8	1.2	1.2	1.1	1.0
	11	2.1	2.0	1.8	1.7
	15	3.6	3.4	3.1	2.9
	18	5.0	4.7	4.3	4.1

UNIT OPERATING CONDITIONS

Table 14a: Size 026 Two-Stage R-410A Typical Unit Operating Pressures and Temperatures

Entering Water Temp °F	Water Flow GPM/ton	Full Load Cooling - without HWG active						Full Load Heating - without HWG active					
		Suction Pressure PSIG	Discharge Pressure PSIG	Super-heat	Sub-cooling	Water Temp Rise °F	Air Temp Drop °F DB	Suction Pressure PSIG	Discharge Pressure PSIG	Super-heat	Sub-cooling	Water Temp Drop °F	Air Temp Rise °F DB
30	1.5	122-132	159-179	13-18	9-14	16.7-18.7	18-24	77-87	278-298	4-9	10-15	5.9-7.9	18-24
	2.25	122-132	146-166	13-18	7-12	12.3-14.3	19-25	79-89	280-300	4-9	10-15	4.2-6.2	19-25
	3	122-132	132-152	14-19	7-12	7.9-9.9	19-25	82-92	282-302	4-9	10-15	2.7-4.7	20-26
50	1.5	132-142	186-206	8-13	8-13	16.3-18.3	18-24	107-117	314-334	6-11	13-18	8.9-10.9	25-31
	2.25	132-142	172-192	8-13	6-11	12.1-14.1	19-25	111-121	315-335	6-11	13-18	6.7-8.7	26-32
	3	132-142	158-178	8-13	6-11	7.8-9.8	19-25	115-125	317-337	6-11	13-18	4.5-6.5	26-32
70	1.5	139-149	281-301	7-12	8-13	15.7-17.7	18-24	139-149	350-370	7-12	15-20	11.3-13.3	31-38
	2.25	139-149	267-287	7-12	8-13	11.6-13.6	18-24	145-155	352-372	7-12	15-20	8.5-10.5	32-39
	3	139-149	253-273	7-12	7-12	7.6-9.6	18-24	152-162	354-374	7-12	15-20	5.8-7.8	32-39
90	1.5	141-151	374-394	7-12	9-14	14.6-16.6	17-23	177-187	392-412	9-14	17-22	14.4-16.4	37-45
	2.25	141-151	360-380	7-12	9-14	10.7-12.7	17-23	181-191	397-417	10-15	17-22	10.8-12.8	38-46
	3	141-151	346-366	7-12	8-13	6.9-8.9	17-23	186-196	402-422	11-16	17-22	7.1-9.1	38-46
110	1.5	145-155	473-493	7-12	10-15	13.6-15.6	16-22	Operation Not Recommended					
	2.25	145-155	458-478	7-12	10-15	9.9-11.9	16-22						
	3	145-155	441-461	7-12	9-14	6.2-8.2	16-22						

Table 14b: Size 038 Two-Stage R-410A Typical Unit Operating Pressures and Temperatures

Entering Water Temp °F	Water Flow GPM/ton	Full Load Cooling - without HWG active						Full Load Heating - without HWG active					
		Suction Pressure PSIG	Discharge Pressure PSIG	Super-heat	Sub-cooling	Water Temp Rise °F	Air Temp Drop °F DB	Suction Pressure PSIG	Discharge Pressure PSIG	Super-heat	Sub-cooling	Water Temp Drop °F	Air Temp Rise °F DB
30	1.5	122-132	153-173	18-23	9-14	22.1-24.1	19-25	71-81	263-283	5-10	2-5	8.1-10.1	17-23
	2.25	121-131	145-165	18-23	8-13	16.8-18.8	20-26	75-85	267-287	5-10	2-5	5.9-7.9	18-24
	3	121-131	135-155	18-23	8-13	10.5-12.5	20-26	78-88	270-290	5-10	2-5	3.7-5.7	19-25
50	1.5	131-141	222-242	13-18	10-15	21.9-23.9	19-25	103-113	292-312	6-11	2.5-7	11.5-13.5	23-29
	2.25	130-140	208-228	13-18	9-14	16.1-18.1	20-26	107-117	296-316	6-11	2.5-7	8.6-10.6	24-30
	3	130-140	194-214	14-19	9-14	10.3-12.3	20-26	112-122	301-321	6-11	2.5-7	5.7-7.7	24-30
70	1.5	138-148	299-319	8-13	13-18	21.5-23.5	19-25	134-144	322-342	7-12	2.5-7	14.5-16.5	28-35
	2.25	137-147	280-300	8-13	12-17	15.8-17.8	20-26	140-150	328-358	7-12	2.5-7	11.1-13.1	29-36
	3	137-147	263-283	8-13	12-17	10-12	20-26	146-156	334-354	7-12	2.5-7	7.7-9.7	30-37
90	1.5	142-152	388-408	6-11	13-18	20.5-22.5	18-24	172-182	360-380	8-13	2.5-7	20.5-22.5	36-44
	2.25	142-152	367-387	7-12	8-13	14.9-16.9	18-24	184-194	369-389	8-13	2.5-7	15-17	37-45
	3	142-152	347-367	7-12	8-13	9.3-11.3	18-24	196-206	378-398	8-13	2.5-7	10-12	39-47
110	1.5	147-157	486-506	6-11	13-18	19-21	18-24	Operation Not Recommended					
	2.25	147-157	465-475	7-12	8-13	14-16	18-24						
	3	147-157	444-464	7-12	8-13	9-11	18-24						

Table 14c: Size 049 Two-Stage R-410A Typical Unit Operating Pressures and Temperatures

Entering Water Temp °F	Water Flow GPM/ton	Full Load Cooling - without HWG active						Full Load Heating - without HWG active					
		Suction Pressure PSIG	Discharge Pressure PSIG	Super-heat	Sub-cooling	Water Temp Rise °F	Air Temp Drop °F DB	Suction Pressure PSIG	Discharge Pressure PSIG	Super-heat	Sub-cooling	Water Temp Drop °F	Air Temp Rise °F DB
30	1.5	112-122	187-207	18-23	23-28	20.7-22.7	19-25	66-76	261-281	8-13	5-10	8-10	18-24
	2.25	111-121	167-187	18-23	21-26	15.5-17.5	19-25	69-79	264-284	8-13	5-10	6-8	19-25
	3	111-121	147-167	18-23	20-25	10.2-12.2	19-25	72-82	267-287	8-13	5-10	4-6	19-25
50	1.5	125-135	245-265	13-18	19-24	20.9-22.9	20-26	93-103	289-309	7-12	5-10	11.5-13.5	23-29
	2.25	123-133	227-247	13-18	18-23	15.6-17.6	20-26	98-108	295-315	7-12	5-10	8.7-10.7	24-30
	3	122-132	208-228	14-19	16-21	10.2-12.2	20-26	103-113	301-321	7-12	5-10	5.9-7.9	25-31
70	1.5	133-143	314-334	9-14	17-22	20.5-22.5	20-26	123-133	319-339	7-12	5-10	15-17	28-35
	2.25	132-142	294-314	9-14	16-21	15.2-17.2	20-26	130-140	329-349	7-12	5-10	11.5-13.5	29-36
	3	131-141	274-294	10-15	14-19	9.9-11.9	20-26	137-147	336-356	7-12	5-10	7.9-9.9	30-37
90	1.5	138-148	401-421	8-13	16-21	19.2-21.2	19-25	167-177	365-385	7-12	5-10	19.6-21.6	37-45
	2.25	137-147	379-399	8-13	15-20	14.3-16.3	19-25	177-187	374-394	7-12	5-10	15-17	38-46
	3	136-146	357-377	9-14	13-18	9.3-11.3	19-25	187-197	388-408	7-12	5-10	10.3-12.3	39-47
110	1.5	144-154	502-522	8-13	14-19	18-20	18-24	Operation Not Recommended					
	2.25	143-153	477-497	8-13	13-18	13.3-15.3	18-24						
	3	142-152	452-472	9-14	12-17	8.5-10.5	18-24						

UNIT OPERATING CONDITIONS

Table 14d: Size 064 Two-Stage R-410A Typical Unit Operating Pressures and Temperatures

Entering Water Temp °F	Water Flow GPM/ton	Full Load Cooling - without HWG active						Full Load Heating - without HWG active					
		Suction Pressure PSIG	Discharge Pressure PSIG	Super-heat	Sub-cooling	Water Temp Rise °F	Air Temp Drop °F DB	Suction Pressure PSIG	Discharge Pressure PSIG	Super-heat	Sub-cooling	Water Temp Drop °F	Air Temp Rise °F DB
30	1.5	117-127	160-180	16-21	8-13	17.5-19.5	16-22	66-76	282-302	9-15	8-13	8-10	21-27
	2.25	116-126	133-153	17-22	6-11	11.9-13.9	16-22	69-79	285-305	9-15	8-13	6-8	21-27
	3	115-125	125-145	18-23	5-10	6.3-8.3	16-22	72-82	289-309	9-15	9-14	4-6	22-28
50	1.5	126-136	228-248	8-13	8-13	19.8-21.8	20-26	95-105	318-338	9-15	12-17	11.3-13.3	27-33
	2.25	124-134	212-232	11-16	6-11	14.2-16.2	20-26	100-110	321-341	9-15	12-17	8.5-10.5	28-34
	3	123-133	195-215	14-19	5-10	8.5-10.5	20-26	105-115	324-344	9-15	12-17	5.7-7.7	30-36
70	1.5	130-140	305-325	8-13	10-15	20.3-22.3	21-27	128-138	360-380	8-14	12-17	14-16	33-38
	2.25	129-139	286-306	9-14	9-14	14.8-16.8	21-27	133-143	364-384	8-14	12-17	10.6-12.6	34-40
	3	128-138	266-286	11-16	7-12	9.3-11.3	21-27	139-149	368-388	8-14	12-17	7.3-9.3	35-41
90	1.5	133-143	398-418	8-13	10-15	19.4-21.4	20-26	173-183	407-427	8-14	13-18	18.2-20.2	42-50
	2.25	132-142	376-396	8-13	9-14	14.1-16.1	20-26	177-187	411-431	8-14	13-18	13.9-15.9	43-51
	3	132-142	354-374	8-13	7-12	8.8-10.8	20-26	182-192	415-435	8-14	14-19	9.6-11.6	44-52
110	1.5	138-148	505-525	6-11	10-15	18.3-20.3	19-25	Operation Not Recommended					
	2.25	137-147	483-503	6-11	9-14	13.3-15.3	19-25						
	3	136-146	459-479	6-11	8-13	8.3-10.3	19-25						

Table 15: R-22 Typical Unit Operating Pressures and Temperatures

Entering Water Temp °F	Water Flow GPM/ton	Full Load Cooling - without HWG active						Full Load Heating - without HWG active					
		Suction Pressure PSIG	Discharge Pressure PSIG	Super-heat	Sub-cooling ****	Water Temp Rise *** °F	Air Temp Drop °F DB	Suction Pressure PSIG	Discharge Pressure PSIG	Super-heat	Sub-cooling ****	Water Temp Drop *** °F	Air Temp Rise °F DB
30	1.5	61-70	100-117	12-18	12-22	21-24	21-26	34-39	163-183	5-10	5-9	7.6-8.4	14-20
	2.3	62-71	92-109	12-18	12-22	13-16	21-26	37-42	165-185	5-10	5-9	4.8-5.6	16-22
	3	62-71	88-104	12-18	12-22	6-11	21-26	38-44	167-186	5-10	5-9	3.4-4.2	16-22
50	1.5	79-85	145-170	10-15	9-16	20-23	20-25	51-58	175-202	9-12	8-12	10.8-11.9	23-29
	2.3	75-83	130-155	10-15	9-16	12-15	20-25	53-62	178-206	9-12	8-12	6.7-8.1	24-30
	3	72-82	125-150	10-15	9-16	8-12	20-25	55-65	180-208	9-12	8-12	5.1-5.9	25-31
70	1.5	78-88	180-200	8-12	7-12	19-22	19-24	71-82	215-250	10-14	6-10	14.0-15.2	28-34
	2.3	78-90	169-187	8-12	7-12	11-14	19-24	77-89	203-235	10-14	6-10	9.0-10.2	30-37
	3	78-91	160-180	8-12	7-12	7-12	19-24	81-92	200-235	10-14	6-10	6.7-7.9	31-38
90	1.5	79-82	230-272	8-10	7-11	18-21	17-23	Operation Not Recommended					
	2.3	80-93	215-248	8-10	7-11	10-14	17-23						
	3	80-93	208-240	8-10	7-11	6-11	17-23						

* Based on Nominal 400 CFM per ton per circuit airflow and 70°F EAT heating and 80/67°F cooling.

** Cooling air and water numbers can vary greatly with changes in humidity.

*** Water temperature difference based upon 1.5 - 3 GPM per ton of active circuit water flow.

**** Using liquid line pressure.

PREVENTIVE MAINTENANCE

Water Coil Maintenance

(Direct ground water applications only)

If the system is installed in an area with a known high mineral content (125 P.P.M. or greater) in the water, it is best to establish a periodic maintenance schedule with the owner so the coil can be checked regularly. Consult the well water applications section of this manual for a more detailed water coil material selection. Should periodic coil cleaning be necessary, use standard coil cleaning procedures, which are compatible with the heat exchanger material and copper water lines. Generally, the more water flowing through the unit, the less chance for scaling. Therefore, 1.5 gpm per ton [2.0 l/m per kW] is recommended as a minimum flow. Minimum flow rate for entering water temperatures below 50°F [10°C] is 2.0 gpm per ton [2.6 l/m per kW].

Water Coil Maintenance

(All other water loop applications)

Generally water coil maintenance is not needed for closed loop systems. However, if the piping is known to have high dirt or debris content, it is best to establish a periodic maintenance schedule with the owner so the water coil can be checked regularly. Dirty installations are typically the result of deterioration of iron or galvanized piping or components in the system. Open cooling towers requiring heavy chemical treatment and mineral buildup through water use can also contribute to higher maintenance. Should periodic coil cleaning be necessary, use standard coil cleaning procedures, which are compatible with both the heat exchanger material and copper water lines. Generally, the more water flowing through the unit, the less chance for scaling. However, flow rates over 3 gpm per ton (3.9 l/m per kW) can produce water (or debris) velocities that can erode the heat exchanger wall and ultimately produce leaks.

Hot Water Generator Coils

See water coil maintenance for ground water units. If the potable water is hard or not chemically softened, the high temperatures of the desuperheater will tend to scale even quicker than the water coil and may need more frequent inspections. In areas with extremely hard water, a HWG is not recommended.

Filters

Filters must be clean to obtain maximum performance. Filters should be inspected every month under normal operating conditions and be replaced when necessary. Units should never be operated without a filter.

Washable, high efficiency, electrostatic filters, when dirty, can exhibit a very high pressure drop for the fan motor and reduce air flow, resulting in poor performance. It is especially important to provide consistent washing of these filters (in the opposite direction of the normal air flow) once per month using a high pressure wash similar to those found at self-serve car washes.

Condensate Drain

In areas where airborne bacteria may produce a “slimy” substance in the drain pan, it may be necessary to treat the drain pan chemically with an algaecide approximately every three months to minimize the problem. The condensate pan may also need to be cleaned periodically to insure indoor air quality. The condensate drain can pick up lint and dirt, especially with dirty filters. Inspect the drain twice a year to avoid the possibility of plugging and eventual overflow.

Compressor

Conduct annual amperage checks to insure that amp draw is no more than 10% greater than indicated on the serial plate data.

Fan Motors

Consult air handler I.O.M. for maintenance requirements.

Air Coil

The air coil must be cleaned to obtain maximum performance. Check once a year under normal operating conditions and, if dirty, brush or vacuum clean. Care must be taken not to damage the aluminum fins while cleaning. CAUTION: Fin edges are sharp.

Cabinet - “Indoor” Compressor Section

Do not allow water to stay in contact with the cabinet for long periods of time to prevent corrosion of the cabinet sheet metal. Generally, cabinets are set up from the floor a few inches [7 - 8 cm] to prevent water from entering the cabinet. The cabinet can be cleaned using a mild detergent.

Refrigerant System

To maintain sealed circuit integrity, do not install service gauges unless unit operation appears abnormal. Reference the operating charts for pressures and temperatures. Verify that air and water flow rates are at proper levels before servicing the refrigerant circuit.

TROUBLESHOOTING

General

If operational difficulties are encountered, perform the preliminary checks below before referring to the troubleshooting charts.

- Verify that the unit is receiving electrical supply power.
- Make sure the fuses in the fused disconnect switches are intact.

After completing the preliminary checks described above, inspect for other obvious problems such as leaking connections, broken or disconnected wires, etc. If everything appears to be in order, but the unit still fails to operate properly, refer to the “CXM Troubleshooting Process Flowchart” or “Functional Troubleshooting Chart.”

CXM Board

CXM board troubleshooting in general is best summarized as simply verifying inputs and outputs. After inputs and outputs have been verified, board operation is confirmed and the problem must be elsewhere. Below are some general guidelines for troubleshooting the CXM control.

Field Inputs

All inputs are 24VAC from the thermostat and can be verified using a volt meter between C and Y, G, O, W. 24VAC will be present at the terminal (for example, between “Y” and “C”) if the thermostat is sending an input to the CXM board.

Sensor Inputs

All sensor inputs are ‘paired wires’ connecting each component to the board. Therefore, continuity on pressure switches, for example can be checked at the board connector.

The thermistor resistance should be measured with the connector removed so that only the impedance of the thermistor is measured. If desired, this reading can be compared to the thermistor resistance chart shown in the CXM/DXM AOM manual. An ice bath can be used to check calibration of the thermistor.

Outputs

The compressor relay is 24VAC and can be verified using a voltmeter. The fan signal is passed through the board to the external fan relay (units with PSC motors only). The alarm relay can either be 24VAC as shipped or dry contacts for use with DDC controls by clipping the JW1 jumper. Electric heat outputs are 24VDC “ground sinking” and require a volt meter set for DC to verify operation. The terminal marked “24VDC” is the 24VDC supply to the electric heat board; terminal “EH1” is stage 1 electric heat; terminal “EH2” is stage 2 electric heat. When electric heat is energized (thermostat is sending a “W” input to the CXM controller), there will be 24VDC between terminal “24VDC” and “EH1” (stage 1 electric heat) and/or “EH2” (stage 2 electric heat). A reading of 0VDC between “24VDC” and “EH1” or “EH2” will indicate that the CXM board is NOT sending an output signal to the electric heat board.

Test Mode

Test mode can be entered for 20 minutes by shorting the test pins. The CXM board will automatically exit test mode after 20 minutes.

CXM Troubleshooting Process Flowchart / Functional Troubleshooting Chart

The “CXM Troubleshooting Process Flowchart” is a quick overview of how to start diagnosing a suspected problem, using the fault recognition features of the CXM board. The “Functional Troubleshooting Chart” on the following page is a more comprehensive method for identifying a number of malfunctions that may occur, and is not limited to just the CXM controls. Within the chart are five columns:

- The “Fault” column describes the symptoms.
- Columns 2 and 3 identify in which mode the fault is likely to occur, heating or cooling.
- The “Possible Cause column” identifies the most likely sources of the problem.
- The “Solution” column describes what should be done to correct the problem.

⚠ WARNING! ⚠

WARNING! HAZARDOUS VOLTAGE!
DISCONNECT ALL ELECTRIC POWER
INCLUDING REMOTE DISCONNECTS
BEFORE SERVICING.

Failure to disconnect power before servicing
can cause severe personal injury or death.

CXM PROCESS FLOW CHART

⚠ WARNING! ⚠

WARNING! HAZARDOUS VOLTAGE!
DISCONNECT ALL ELECTRIC POWER
INCLUDING REMOTE DISCONNECTS
BEFORE SERVICING.

Failure to disconnect power before servicing
can cause severe personal injury or death.

CXM Functional Troubleshooting Chart

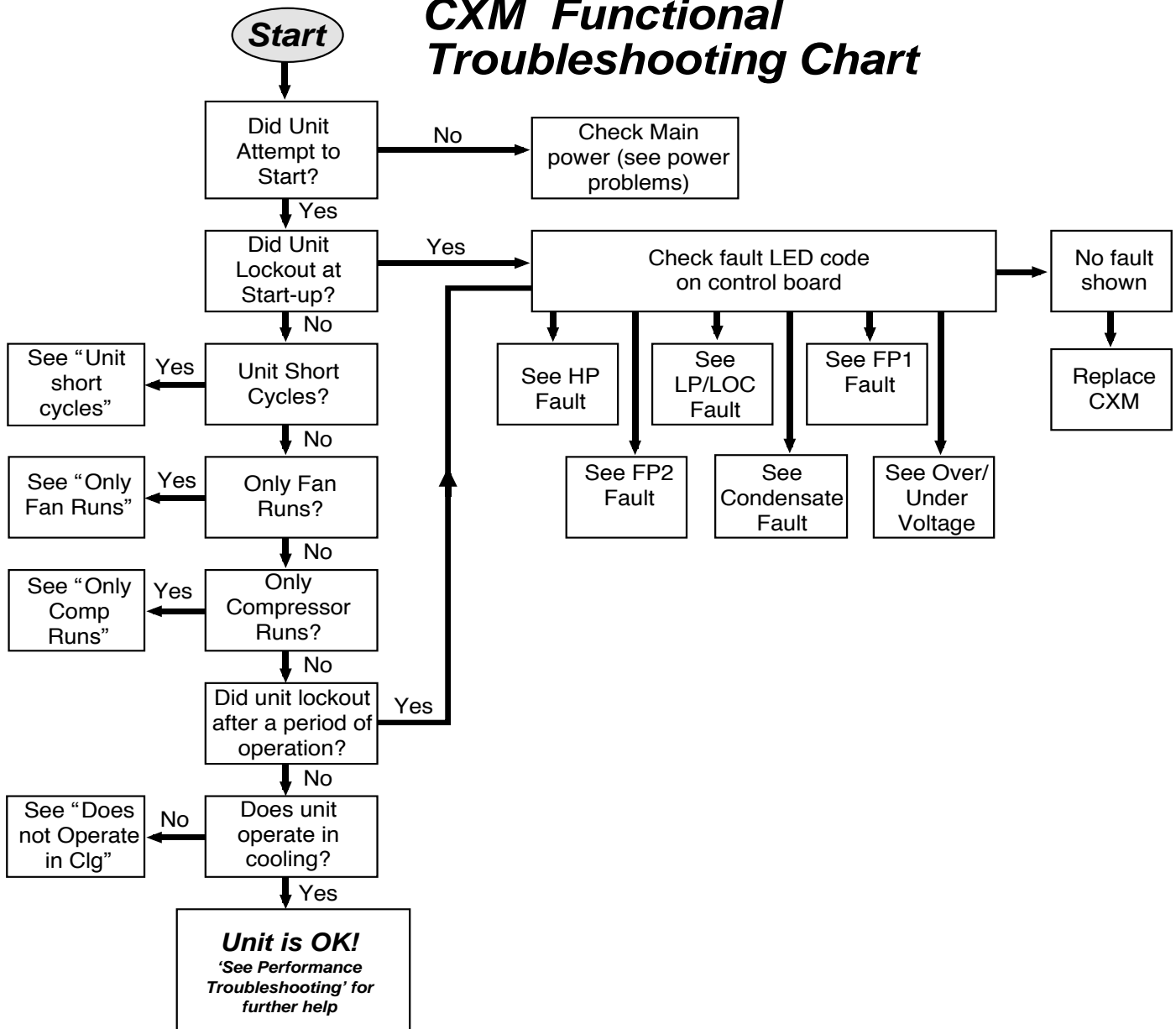

FUNCTIONAL TROUBLESHOOTING

Fault	Htg	Clg	Possible Cause	Solution
Main power Problems	X	X	Green Status LED Off	Check Line Voltage circuit breaker and disconnect Check for line voltage between L1 and L2 on the contactor Check for 24VAC between R and C on CXM/DXM Check primary/secondary voltage on transformer
		X	Reduced or no water flow in cooling	Check pump operation or valve operation/setting Check water flow adjust to proper flow rate
		X	Water Temperature out of range in cooling	Bring water temp within design parameters
		X	Reduced or no Air flow in heating	Check for dirty air filter and clean or replace Check fan motor operation and airflow restrictions Dirty Air Coil- construction dust etc. Too high of external static. Check static vs blower table
X		Air Temperature out of range in heating	Bring return air temp within design parameters	
X		X	Overcharged with refrigerant	Check superheat/subcooling vs typical operating condition table
X		X	Bad HP Switch	Check switch continuity and operation. Replace
LP/LOC Fault-Code 3 Low Pressure/Loss of Charge	X	X	Insufficient charge	Check for refrigerant leaks
	X		Compressor pump down at start-up	Check charge and start-up water flow
FP1 Fault - Code 4 Water Coil low temperature limit	X		Reduced or no water flow in heating	Check pump operation or water valve operation/setting Plugged strainer or filter. Clean or replace. Check water flow adjust to proper flow rate
	X		Inadequate anti-freeze level	Check antifreeze density with hydrometer
	X		Improper temperature limit setting (30°F vs 10°F [-1°C vs -12°C])	Clip JW3 jumper for antifreeze (10°F [-12°C]) use
	X		Water Temperature out of range	Bring water temp within design parameters
	X	X	Bad thermistor	Check temp and impedance correlation per chart
FP2 fault - Code 5 Air Coil low temperature limit		X	Reduced or no Air flow in cooling	Check for dirty air filter and clean or replace Check fan motor operation and airflow restrictions Too high of external static. Check static vs blower table
		X	Air Temperature out of range	Too much cold vent air? Bring entering air temp within design parameters
		X	Improper temperature limit setting (30°F vs 10°F [-1°C vs -12°C])	Normal airside applications will require 30°F [-1°C] only
	X	X	Bad thermistor	Check temp and impedance correlation per chart
Condensate Fault-Code 6	X	X	Blocked Drain	Check for blockage and clean drain
	X	X	Improper trap	Check trap dimensions and location ahead of vent
		X	Poor Drainage	Check for piping slope away from unit Check slope of unit toward outlet Poor venting. Check vent location
		X	Moisture on sensor	Check for moisture shorting to air coil
Over/Under Voltage-Code 7 (Auto resetting)	X	X	Under Voltage	Check power supply and 24VAC voltage before and during operation. Check power supply wire size Check compressor starting. Need hard start kit? Check 24VAC and unit transformer tap for correct power supply voltage
	X	X	Over Voltage	Check power supply voltage and 24VAC before and during operation. Check 24VAC and unit transformer tap for correct power supply voltage
Unit Performance Sentinel-Code 8	X		Heating mode FP2>125°F [52°C]	Check for poor air flow or overcharged unit.
		X	Cooling Mode FP1>125°F [52°C] OR FP2< 40°F [4°C]	Check for poor water flow, or air flow
No Fault Code Shown	X	X	No compressor operation	See "Only fan operates"
	X	X	Compressor Overload	Check and Replace if necessary
	X	X	Control board	Reset power and check operation
Unit Short Cycles	X	X	Dirty Air Filter	Check and Clean air filter
	X	X	Unit in "Test Mode"	Reset power or wait 20 minutes for auto exit.
	X	X	Unit selection	Unit may be oversized for space. Check sizing for actual load of space.
	X	X	Compressor Overload	Check and Replace if necessary
Only Fan Runs	X	X	Thermostat position	Insure thermostat set for heating or cooling operation
	X	X	Unit locked out	Check for lockout codes. Reset power.
	X	X	Compressor Overload	Check compressor overload. Replace if necessary.
	X	X	Thermostat wiring	Check thermostat wiring at heat pump. Jumper Y and R for compressor operation in test mode.

FUNCTIONAL TROUBLESHOOTING

Only Compressor Runs	X	X	Thermostat wiring	Check G wiring at heat pump. Jumper G and R for fan operation.
	X	X	Fan motor relay	Jumper G and R for fan operation. Check for Line voltage across BR contacts. Check fan power enable relay operation (if present)
	X	X	Fan motor	Check for line voltage at motor. Check capacitor
	X	X	Thermostat wiring	Check thermostat wiring at heat pump. Jumper Y and R for compressor operation in test mode.
Unit Doesn't Operate in Cooling		X	Reversing Valve	Set for cooling demand and check 24VAC on RV coil and at CXM/DXM board. If RV is stuck, run high pressure up by reducing water flow and while operating engage and disengage RV coil voltage to push valve.
		X	Thermostat setup	Check for 'O' RV setup not 'B'
		X	Thermostat wiring	Check O wiring at heat pump. Jumper O and R for RV coil 'Click'.
		X	Thermostat wiring	Put thermostat in cooling mode. Check for 24VAC on O (check between C and O); check for 24VAC on W (check between W and C). There should be voltage on O, but not on W. If voltage is present on W, thermostat may be bad or wired incorrectly.

PERFORMANCE TROUBLESHOOTING

Performance Troubleshooting	Htg	Clg	Possible Cause	Solution
Insufficient capacity/ Not cooling or heating properly	X	X	Dirty Filter	Replace or clean
	X		Reduced or no Air flow in heating	Check for dirty air filter and clean or replace Check fan motor operation and airflow restrictions Too high of external static. Check static vs blower table
		X	Reduced or no Air flow in cooling	Check for dirty air filter and clean or replace Check fan motor operation and airflow restrictions Too high of external static. Check static vs blower table
	X	X	Leaky duct work	Check supply and return air temperatures at the unit and at distant duct registers if significantly different, duct leaks are present
	X	X	Low refrigerant charge	Check superheat and subcooling per chart
	X	X	Restricted metering device	Check superheat and subcooling per chart. Replace.
		X	Defective Reversing Valve	Perform RV touch test
	X	X	Thermostat improperly located	Check location and for air drafts behind stat
	X	X	Unit undersized	Recheck loads & sizing check sensible clg load and heat pump capacity
	X	X	Scaling in water heat exchanger	Perform Scaling check and clean if necessary
	X	X	Inlet Water too Hot or Cold	Check load, loop sizing, loop backfill, ground moisture.
	High Head Pressure	X		Reduced or no Air flow in heating
		X	Reduced or no water flow in cooling	Check pump operation or valve operation/setting Check water flow adjust to proper flow rate
		X	Inlet Water too Hot	Check load, loop sizing, loop backfill, ground moisture.
X			Air Temperature out of range in heating	Bring return air temp within design parameters
		X	Scaling in water heat exchanger	Perform Scaling check and clean if necessary
X		X	Unit Overcharged	Check superheat and subcooling. Reweigh in charge
X		X	Non-condensables insystem	Vacuum system and reweigh in charge
X		X	Restricted metering device	Check superheat and subcooling per chart. Replace.
Low Suction Pressure	X		Reduced water flow in heating	Check pump operation or water valve operation/setting Plugged strainer or filter. Clean or replace. Check water flow adjust to proper flow rate
	X		Water Temperature out of range	Bring water temp within design parameters
		X	Reduced Air flow in cooling	Check for dirty air filter and clean or replace Check fan motor operation and airflow restrictions Too high of external static. Check static vs blower table
		X	Air Temperature out of range	Too much cold vent air? Bring entering air temp within design parameters
	X	X	Insufficient charge	Check for refrigerant leaks
Low discharge air temperature in heating	X		Too high of air flow	Check fan motor speed selection and airflow chart
	X		Poor Performance	See 'Insufficient Capacity'
High humidity		X	Too high of air flow	Check fan motor speed selection and airflow chart
		X	Unit oversized	Recheck loads & sizing check sensible clg load and heat pump capacity

TROUBLESHOOTING FORM

Customer: _____ Antifreeze: _____

Model#: _____ Serial#: _____ Loop type: _____

Complaint: _____

HEATING CYCLE ANALYSIS -

Refrigerant Type:

- R410A
- R22
- R407C

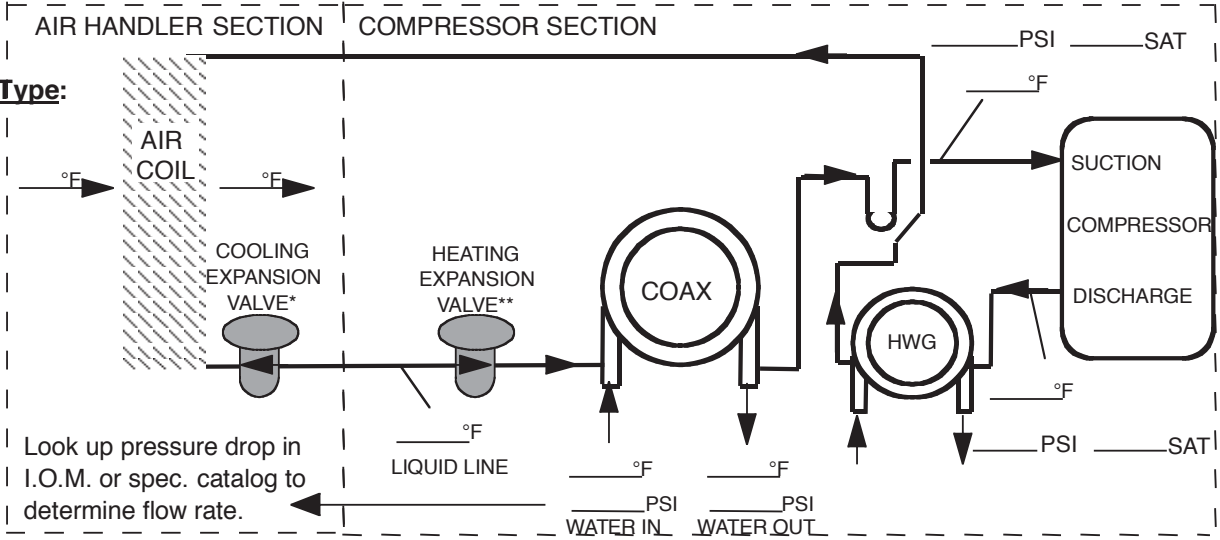

COOLING CYCLE ANALYSIS -

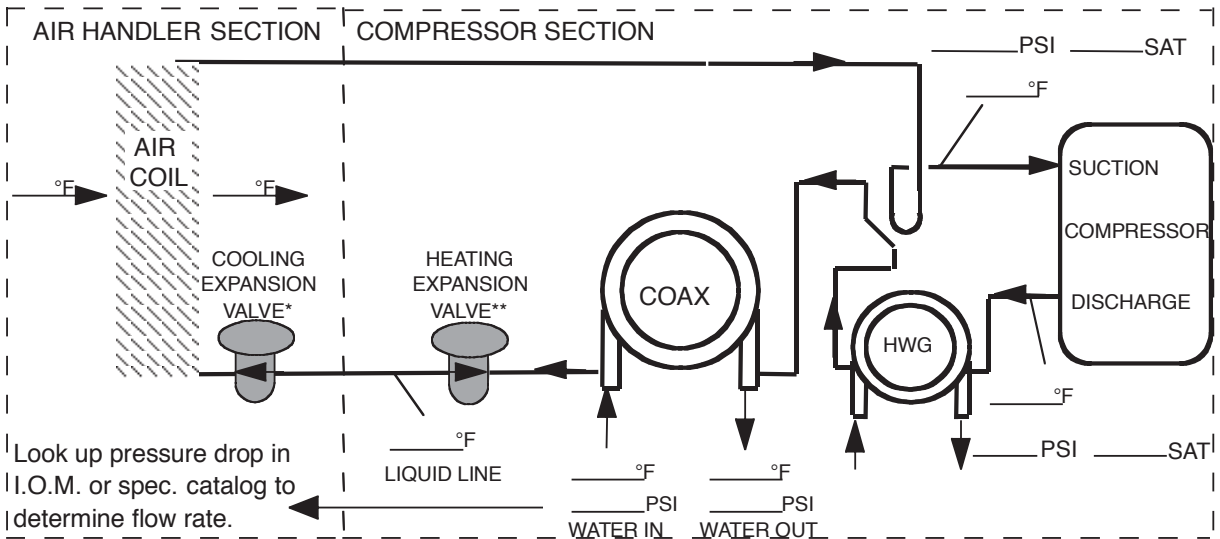

*Cooling expansion valve meters in the cooling mode, and bypasses in the heating mode.

**Heating expansion valve meters in the heating mode, and bypasses in the cooling mode.

Heat of Extraction (Absorption) or Heat of Rejection =

_____ flow rate (gpm) x _____ temp. diff. (deg. F) x _____ fluid factor † = _____ (Btu/hr)

Superheat = suction temperature - suction saturation temp. = _____ (deg F)

Subcooling = discharge saturation temp. - liquid line temp. = _____ (deg F)

†Use 500 for water, 485 for antifreeze.

Note: Never connect refrigerant gauges during startup procedures. Conduct water-side analysis using P/T ports to determine water flow and temperature difference. If water-side analysis shows poor performance, refrigerant troubleshooting may be required. Connect refrigerant gauges as a last resort.

WARRANTY

CARRIER CORPORATION LIMITED EXPRESS WARRANTY/LIMITATION OF REMEDIES AND LIABILITY FOR RESIDENTIAL GEOTHERMAL PRODUCTS



It is expressly understood that unless a statement is specifically identified as a warranty, statements made by Carrier Corporation, a Delaware corporation, ("Carrier") or its representatives, relating to Carrier's products, whether oral, written or contained in any sales literature, catalog or agreement, are not express warranties and do not form a part of the basis of the bargain, but are merely Carrier's opinion or commendation of Carrier's products. **EXCEPT AS SPECIFICALLY SET FORTH HEREIN, THERE IS NO EXPRESS WARRANTY AS TO ANY OF CARRIER'S PRODUCTS. CARRIER MAKES NO WARRANTY AGAINST LATENT DEFECTS. CARRIER MAKES NO WARRANTY OF MERCHANTABILITY OF THE GOODS OR OF THE FITNESS OF THE GOODS FOR ANY PARTICULAR PURPOSE.**

GRANT OF LIMITED EXPRESS WARRANTY

Carrier warrants its residential geothermal products, purchased and retained in the United States of America and Canada, to be free from defects in material and workmanship under normal use and maintenance as follows: (1) 38WQS heat pump units built or sold by Carrier ("Carrier Geothermal Units") for five (5) years from the Warranty Inception Date (as defined below); (2) Auxiliary electric heaters and geothermal pumping modules built or sold by Carrier, when installed with Carrier Geothermal Units, for five (5) years from the Warranty Inception Date (as defined below); (3) Sealed refrigerant circuit components of Carrier Geothermal Units (which components only include the compressor, refrigerant to air/water heat exchangers, reversing valve body and refrigerant metering device) for ten (10) years from the Warranty Inception Date (as defined below). The "Warranty Inception Date" shall be the date of original unit installation, or six (6) months from date of unit shipment from Carrier, whichever comes first.

To make a claim under this warranty, parts must be returned to Carrier in Oklahoma City, Oklahoma, freight prepaid, no later than ninety (90) days after the date of the failure of the part; if Carrier determines the part to be defective and within Carrier's Limited Express Warranty, Carrier shall, when such part has been either replaced or repaired, return such to a factory recognized distributor, dealer or service organization, F.O.B. Carrier, Oklahoma City, Oklahoma, freight prepaid. The warranty on any part repaired or replaced under warranty expires at the end of the original warranty period.

This warranty does not cover and does not apply to: (1) Air filters, fuses, refrigerant, fluids, oil; (2) Products relocated after initial installation; (3) Any portion or component of any system that is not supplied by Carrier, regardless of the cause of the failure of such portion or component; (4) Products on which the unit identification tags or labels have been removed or defaced; (5) Products on which payment to Carrier, or to the owner's seller, is in default; (6) Products subjected to improper or inadequate installation, maintenance, repair, wiring or voltage conditions; (7) Products subjected to accident, misuse, negligence, abuse, fire, flood, lightning, unauthorized alteration, misapplication, contamination or corrosive air or liquid supply, operation at abnormal air or liquid temperatures or flow rates, or opening of the refrigerant circuit by unqualified personnel; (8) Mold, fungus or bacteria damages; (9) Corrosion or abrasion of the product; (10) Products supplied by others; (11) Products which have been operated in a manner contrary to Carrier's printed instructions; (12) Products which have insufficient performance as a result of improper application, installation, or use of Carrier's products; or (13) Electricity or fuel costs, or any increases or unrealized savings in same, for any reason whatsoever.

Carrier is not responsible for: (1) The costs of any fluids, refrigerant or system components supplied by others, or associated labor to repair or replace the same, which is incurred as a result of a defective part covered by Carrier's Limited Express Warranty; (2) The costs of labor, refrigerant, materials or service incurred in diagnosis and removal of the defective part, or in obtaining and replacing the new or repaired part; (3) Transportation costs of the defective part from the installation site to Carrier, or of the return of that part if not covered by Carrier's Limited Express Warranty; or (4) The costs of normal maintenance.

This Limited Express Warranty applies to Carrier Residential Geothermal products manufactured on or after June 9, 2003 (Carrier Geothermal Units with serial numbers beginning with 2403 or later), and is not retroactive to any products produced prior to June 9, 2003 (Carrier Geothermal Units with serial numbers beginning with 2303 and earlier).

Limitation: This Limited Express Warranty is given in lieu of all other warranties. If, notwithstanding the disclaimers contained herein, it is determined that other warranties exist, any such express warranty, including without limitation any express warranties or any implied warranties of fitness for particular purpose and merchantability, shall be limited to the duration of the Limited Express Warranty.

LIMITATION OF REMEDIES

In the event of a breach of the Limited Express Warranty, Carrier will only be obligated at Carrier's option to repair the failed part or unit, or to furnish a new or rebuilt part or unit in exchange for the part or unit which has failed. If after written notice to Carrier's factory in Oklahoma City, Oklahoma of each defect, malfunction or other failure, and a reasonable number of attempts by Carrier to correct the defect, malfunction or other failure, and the remedy fails of its essential purpose, Carrier shall refund the purchase price paid to Carrier in exchange for the return of the sold good(s). Said refund shall be the maximum liability of Carrier. **THIS REMEDY IS THE SOLE AND EXCLUSIVE REMEDY OF THE BUYER OR PURCHASER AGAINST CARRIER FOR BREACH OF CONTRACT, FOR THE BREACH OF ANY WARRANTY, OR FOR CARRIER'S NEGLIGENCE OR IN STRICT LIABILITY.**

LIMITATION OF LIABILITY

Carrier shall have no liability for any damages if Carrier's performance is delayed for any reason or is prevented to any extent by any event such as, but not limited to: any war, civil unrest, government restrictions or restraints, strikes, or work stoppages, fire, flood, accident, shortages of transportation, fuel, material, or labor, acts of God or any other reason beyond the sole control of Carrier. **CARRIER EXPRESSLY DISCLAIMS AND EXCLUDES ANY LIABILITY FOR CONSEQUENTIAL OR INCIDENTAL DAMAGE IN CONTRACT, FOR BREACH OF ANY EXPRESS OR IMPLIED WARRANTY, OR IN TORT, WHETHER FOR CARRIER'S NEGLIGENCE OR AS STRICT LIABILITY.**

OBTAINING WARRANTY PERFORMANCE

Normally, the dealer or service organization who installed the products will provide warranty performance for the owner. Should the installer be unavailable, contact any Carrier recognized distributor, dealer or service organization. If assistance is required in obtaining warranty performance, write or call:

Carrier Corporation • Customer Service • 7300 SW 44th Street • Oklahoma City, Oklahoma 73179 • (405) 745-2920

NOTE: Some states or Canadian provinces do not allow limitations on how long an implied warranty lasts, or the limitation or exclusions of consequential or incidental damages, so the foregoing exclusions and limitations may not apply to you. This warranty gives you specific legal rights, and you may also have other rights which vary from state to state and from Canadian province to Canadian province.

Please refer to the Carrier Installation, Operation and Maintenance Manual for operating and maintenance instructions.

Rev.: 04/06
Part No.: CA185

IOM Revision Log:

Date	Page #	Description
28 June, 2007	13	Updated flow controller mounting instructions
24 Aug, 2006	All	Various Formatting Changes and Corrections
24 Aug, 2006	29, 30	Updated Electrical Data
24 Aug, 2006	17, 33	Added Motorized Water Valve Cautions
10 Aug, 2005	All	First Published



97B0048N01

7300 S.W. 44th Street
 Oklahoma City, OK 73179
 Phone: 405-745-2920
 Fax: 405-745-6620

The Manufacturer works continually to improve its products. As a result, the design and specifications of each product at the time for order may be changed without notice and may not be as described herein. Please contact Manufacturer's Customer Service Department at 1-405-745-2920 for specific information on the current design and specifications. Statements and other information contained herein are not express warranties and do not form the basis of any bargain between the parties, but are merely Manufacturer's opinion or commendation of its products.

The management system governing the manufacture of The Manufacturer's products is ISO 9001:2000 certified.