

50YEW Series



Water-to-Water (50YEW) Series
60Hz Models

Residential High Temperature
Water-to-Water
Geothermal Heat Pumps
(Heating Only)

Installation, Operation &
Maintenance Instructions
97B0064N01
Revision: 31 Jan, 2008D

Table of Contents

Model Nomenclature	2	Electrical - Controls	16
General Information	3	User Interface	19
Physical Data	4	Installer Interface	20
Dimensional Data	5	Wiring Diagram Matrix	21
Installation	6	Typical Wiring Diagrams	22
Load Plumbing Installation	7	Unit Starting & Operating Conditions	26
Ground-Water Heat Pump Application	8	Unit & System Checkout	27
Water Quality Standards	9	Unit Start-Up Procedure	28
Ground-Loop Heat Pump Application	10	Preventive Maintenance	29
Electrical - Power Wiring	13	Warranty	30
Electrical - Low Voltage Wiring	13	Revision History	32

MODEL NOMENCLATURE

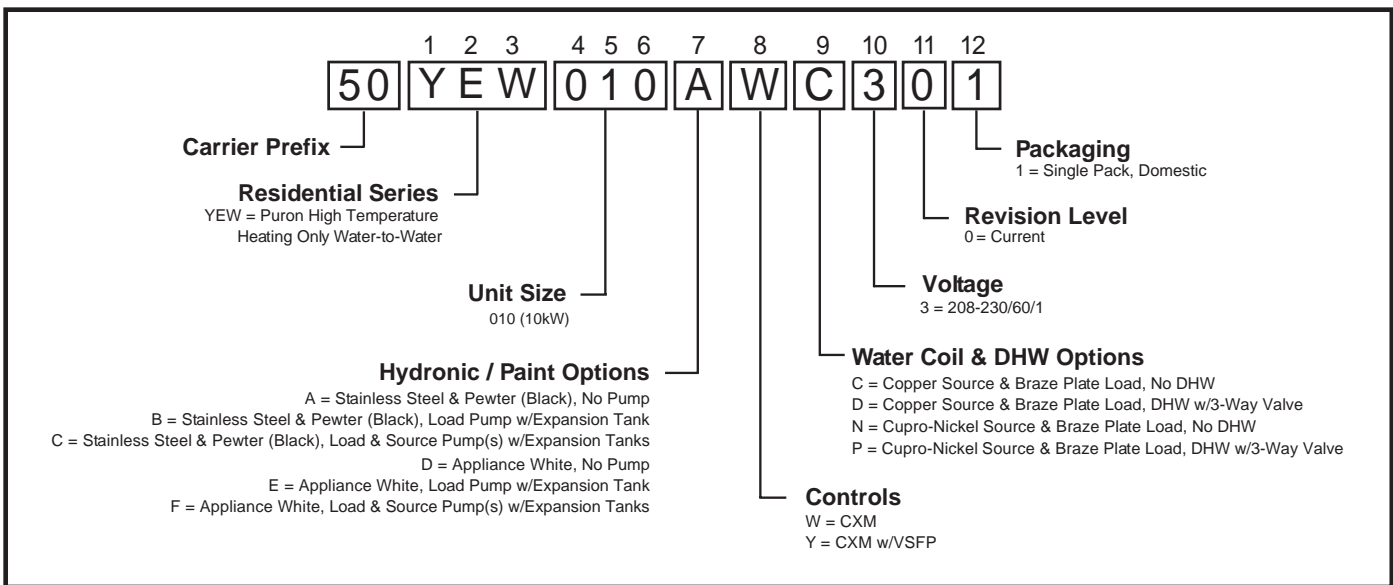

Safety

Warnings, cautions and notices appear throughout this manual. Read these items carefully before attempting any installation, service or troubleshooting of the equipment.

DANGER: Indicates an immediate hazardous situation, which if not avoided will result in death or serious injury. DANGER labels on unit access panels must be observed.

WARNING: Indicates a potentially hazardous situation, which if not avoided could result in death or serious injury.

CAUTION: Indicates a potentially hazardous situation or an unsafe practice, which if not avoided could result in minor or moderate injury or product or property damage.

NOTICE: Notification of installation, operation or maintenance information, which is important, but which is not hazard-related.

⚠ WARNING! ⚠

WARNING! Units are shipped with R-410A (Puron®) refrigerant. The Puron® Application and Service Manual should be read and understood before attempting to service refrigerant circuits with R-410A.

⚠ WARNING! ⚠

WARNING! To avoid the release of refrigerant into the atmosphere, the refrigerant circuit of this unit must be serviced only by technicians who meet local, state, and federal proficiency requirements.

⚠ WARNING! ⚠

WARNING! All refrigerant discharged from this unit must be recovered WITHOUT EXCEPTION. Technicians must follow industry accepted guidelines and all local, state, and federal statutes for the recovery and disposal of refrigerants. If a compressor is removed from this unit, refrigerant circuit oil will remain in the compressor. To avoid leakage of compressor oil, refrigerant lines of the compressor must be sealed after it is removed.

⚠ CAUTION! ⚠

CAUTION! To avoid equipment damage, DO NOT use these units as a source of heating or cooling during the construction process. The mechanical components and filters will quickly become clogged with construction dirt and debris, which may cause system damage.

GENERAL INFORMATION

Inspection

Upon receipt of the equipment, carefully check the shipment against the bill of lading. Make sure all units have been received. Inspect the carton or crating of each unit, and inspect each unit for damage. Assure the carrier makes proper notation of any shortages or damage on all copies of the freight bill and completes a common carrier inspection report. Concealed damage not discovered during unloading must be reported to the carrier within 15 days of receipt of shipment. **If not filed within 15 days, the freight company can deny the claim without recourse. Note: It is the responsibility of the purchaser to file all necessary claims with the carrier.** Notify the Traffic Department of all damage within fifteen (15) days of shipment.

Storage

Equipment should be stored in its shipping carton in a clean, dry area. Store units in an upright position at all times. Stack units a maximum of 3 units high.

Unit Protection

Cover units on the job site with either shipping cartons, vinyl film, or an equivalent protective covering. Cap the open ends of pipes stored on the job site. In areas where painting, plastering, and/or spraying has not been completed, all due precautions must be taken to avoid physical damage to the units and contamination by foreign material. Physical damage and contamination may prevent proper start-up and may result in costly equipment clean-up.

Examine all pipes, fittings, and valves before installing any of the system components. Remove any dirt or trash found in or on these components.

Pre-Installation

Installation, Operation, and Maintenance instructions are provided with each unit. The installation site chosen should include adequate service clearance around the unit. Before unit start-up, read all manuals and become familiar with the unit and its operation. Thoroughly check the system before operation.

Prepare units for installation as follows:

1. Compare the electrical data on the unit nameplate with ordering and shipping information to verify that the correct unit has been shipped.
2. Keep the cabinet covered with the shipping carton until installation is complete and all plastering, painting, etc. is finished.
3. Verify refrigerant tubing is free of kinks or dents and that it does not touch other unit components.
4. Inspect all electrical connections. Connections must be clean and tight at the terminals.
5. Locate and verify any HWG or other accessory sensors located in the compressor section.

⚠ CAUTION! ⚠

CAUTION! DO NOT store or install units in corrosive environments or in locations subject to temperature or humidity extremes (e.g., attics, garages, rooftops, etc.). Corrosive conditions and high temperature or humidity can significantly reduce performance, reliability, and service life. Always move and store units in an upright position. Tilting units on their sides may cause equipment damage.

⚠ CAUTION! ⚠

CAUTION! CUT HAZARD - Failure to follow this caution may result in personal injury. Sheet metal parts may have sharp edges or burrs. Use care and wear appropriate protective clothing, safety glasses and gloves when handling parts and servicing heat pumps.

PHYSICAL DATA

Model	010
Compressor (qty)	1
Factory Charge R410A (oz) [kg]	88 [2.50]
Indoor/Load Water Connection Size	
IPT (in)	1
Outdoor/Source Water Connection Size	
IPT (in)	1
Domestic Hot Water Connection Size	
IPT (in)	1
Maximum Working Pressure (Water Side)	
Base Unit (PSIG) [kPa]	500 [3445]
DHW Option (PSIG) [kPa]	500 [3445]
Internal Source Pump w/Expansion Tank (PSIG) [kPa]	45 [310]
Internal Load Pump w/Expansion Tank (PSIG) [kPa]	45 [310]
Weight - Operating, (lbs) [kg]	455 [207]
Weight - Packaged, (lbs) [kg]	470 [214]

Dual isolation compressor mounting
Balanced Port Expansion Valve (TXV)
Insulated Source and Load Water Coils

DIMENSIONS

Notes:

1. Front, Side, and Top access is preferred for service access. However, all components may be serviced from the front and Top access panels if side access is not available.
2. While clear access to all removable panels is not required, installer should take care to comply with all building codes and allow adequate clearance for future field service.

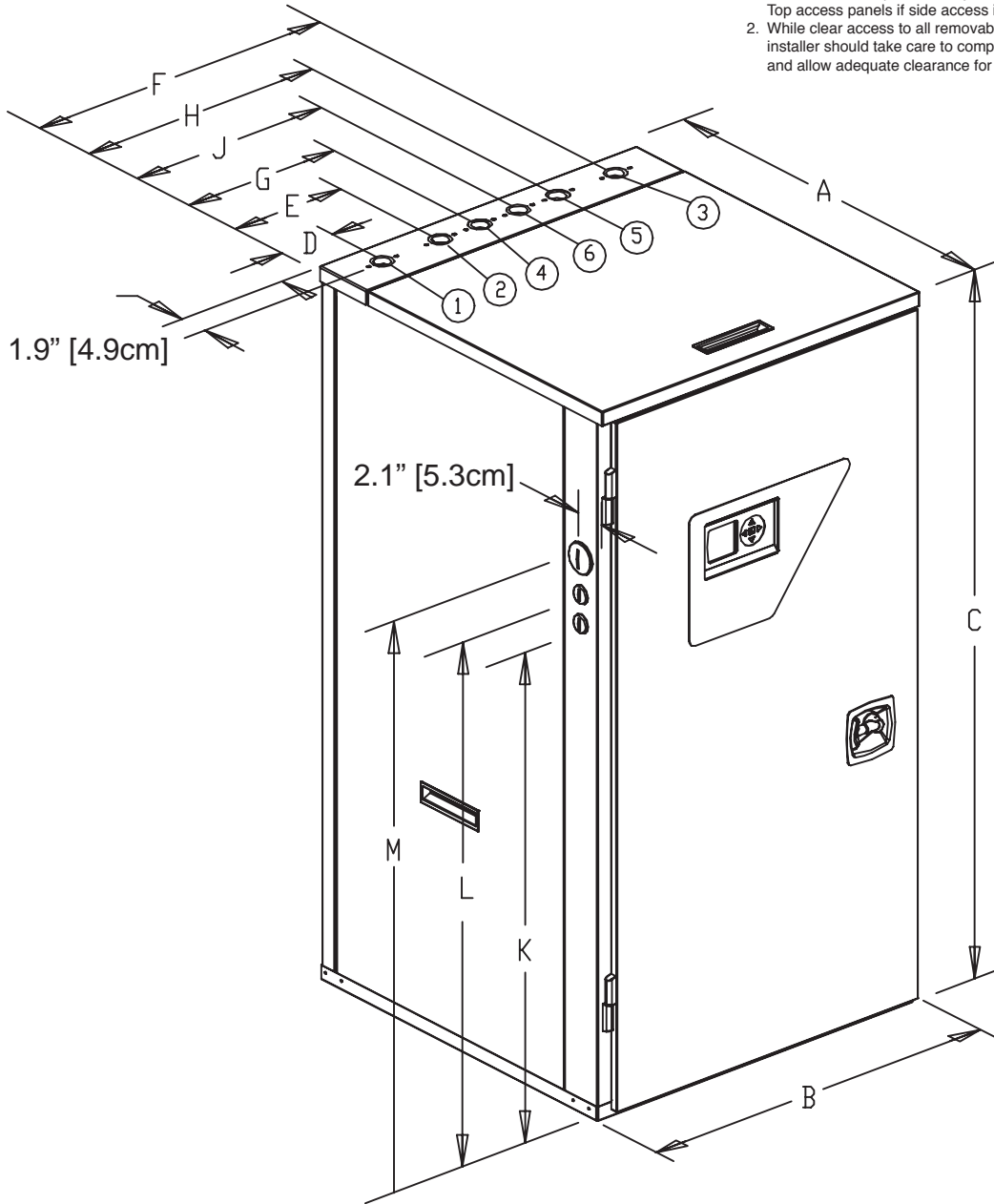

Model	Overall Cabinet			Water Connections						Electric Access Plugs			
	A Depth	B Width	C Height	1	2	3	4	5	6	K Low Voltage	L Low Voltage	M Power Supply	
				D Source (Outdoor) Water In	E Source (Outdoor) Water Out	F Load (Indoor) Water In	G Load (Indoor) Water Out	H DHW Return In	J DHW Water Out				
010	in.	26.8	25.6	48.9	3.4	8.1	22.3	11.3	17.7	14.4	33.6	35.6	38.0
	cm.	68.1	65.1	124.2	8.6	20.6	56.6	28.7	45.0	36.6	85.3	90.4	96.5

INSTALLATION

50YEW Unit Location

These units are not designed for outdoor installation. Locate the unit in an INDOOR area that allows enough space for service personnel to perform typical maintenance or repairs.

The installation of water source heat pump units and all associated components, parts and accessories which make up the installation shall be in accordance with the regulations of ALL authorities having jurisdiction and MUST conform to all applicable codes. It is the responsibility of the Installing Contractor to determine and comply with ALL applicable codes and regulations.

Locate the unit in an indoor area that allows easy removal of access panels, and has enough space for service personnel to perform maintenance or repair. Provide sufficient room to make water and electrical connections. Any access panel screws that would be difficult to remove after the unit is installed should be removed prior to setting the unit. These units are not approved for outdoor installation and, therefore, must be installed inside the structure being conditioned. Do not locate in areas where ambient conditions are not maintained within 40-100°F [4-38°C] and up to 75% relative humidity.

LOAD PLUMBING INSTALLATION

50YEW Unit Load Plumbing

The applications are too varied to describe in this document, however some basic guidelines will be presented. All plumbing should conform to local codes and consider the following:

Wide temperature variation applications such as heating/cooling coils

- Employ piping materials that are rated for the maximum temperature and pressure combination. This excludes PVC for most heating applications.
- Insure load water flow in high temperature heating applications is at least 3 gpm per ton [3.2 l/m per kW] to improve performance and reduce nuisance high pressure faults.
- DO NOT employ plastic to metal threaded joints
- Utilize a pressure tank and air separator vent system to equalize pressure and remove air.

Swimming Pool Hot Tub Applications

- Recommended application includes a brazed plate heat exchanger to isolate pool water from the unit heat exchanger.

Potable Water Applications

- Insure load water flow in high temperature heating applications is at least 3 gpm per ton [3.2 l/m per kW] to improve performance and reduce nuisance high pressure faults.
- A secondary heat exchanger must always be used between the water-to-water heat pump and potable water tank. Either an indirect water heat or brazed plate heat exchanger (with a secondary pump) will isolate the potable water from the heating water.

Load Piping Connections

Load piping connections are designated 'Load Water In and Out' for the radiant heating system piping, and 'DHW Water In and Out' (optional) for connection to the domestic hot water piping. Any unused piping connections on the load side of the 50YEW unit will allow spillage of the load circuit fluid, as the radiant and DHW circuits are connected internally.

If a unit is ordered with the DHW option and is not being connected to a radiant heating system, the 'Load Water In and Out' (radiant heating circuit) connections must be connected to the 'DHW In and Out' piping using tees as shown in Figure 1a. Failure to do so will lead to nuisance high-pressure faults.

Figure 1a: 50YEW DHW Only Piping

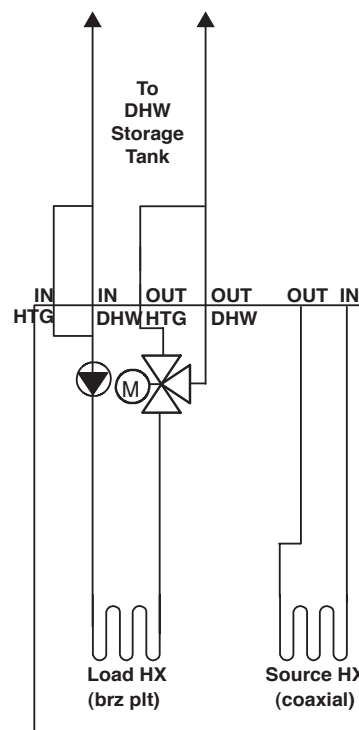

LOAD PLUMBING INSTALLATION

Figure 1b: 50YEW Typical Load Piping

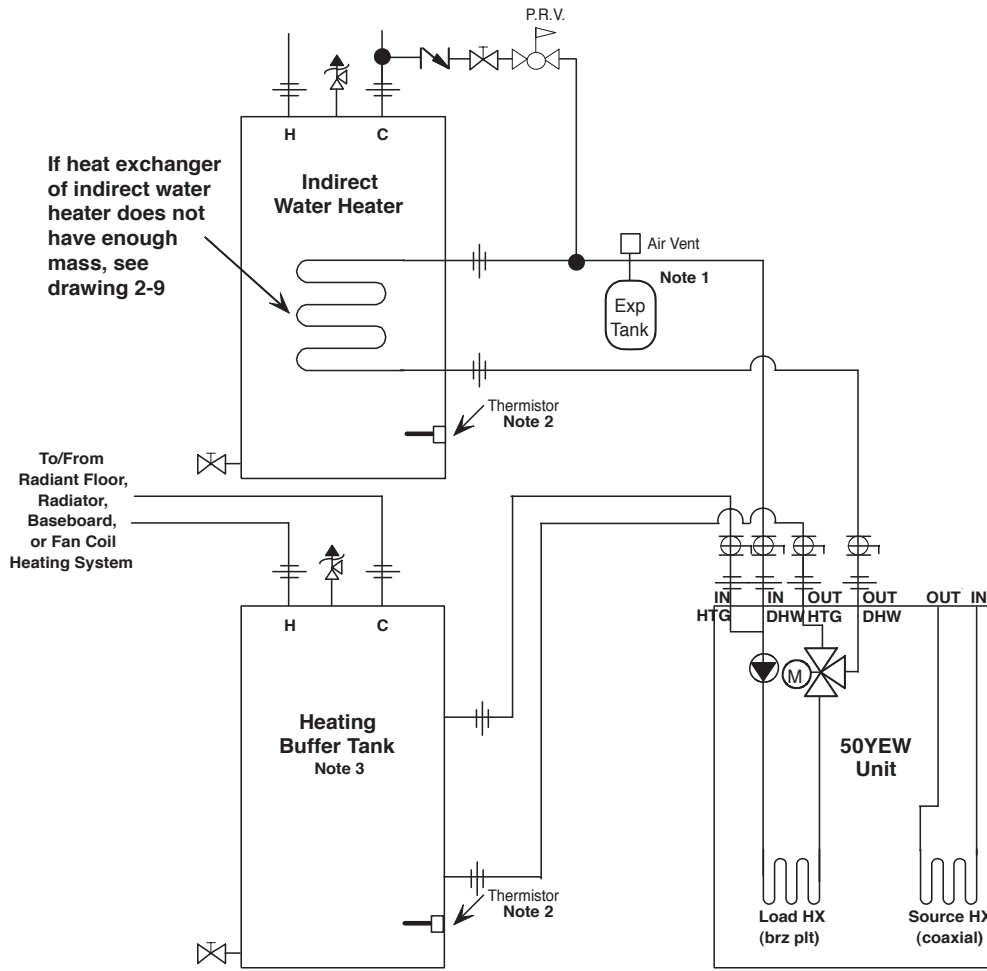

03Oct07

GROUND-WATER HEAT PUMP SYSTEMS

Typical open loop piping is shown in Figure 2. Shut off valves should be included in case of servicing. Boiler drains or other valves should be 'tee'd' into the line to allow acid flushing of just the heat exchanger. Pressure temperature plugs should be used so that flow and temperature can be measured. Piping materials should be limited to PVC SCH80 or copper. **Due to the pressure and temperature extremes, PVC SCH40 is not recommended.** Water quantity should be plentiful and of good quality. Consult Table 2 for water quality guidelines. The unit can be ordered with either a copper or cupro-nickel water heat exchanger. Copper is recommended for closed loop systems and open loop ground water systems that are not high in mineral content or corrosiveness. In conditions anticipating heavy scale formation or in brackish water, a cupro-nickel heat exchanger is recommended. In ground water situations where scaling could be heavy or where biological growth such as iron bacteria will be present, a closed loop system is recommended. Heat exchanger coils may over time lose heat exchange capabilities due to a build up of mineral deposits inside. These can be cleaned only by a qualified service mechanic as acid and special pumping equipment are required.

Desuperheater coils can likewise become scaled and possibly plugged. In areas with extremely hard water, the homeowner should be informed that the heat exchanger may require occasional acid flushing.

Expansion Tank and Pump

Use a closed, bladder-type expansion tank to minimize mineral formation due to air exposure. The expansion tank should be sized to handle at least one minute run time of the pump to prevent premature pump failure using its drawdown capacity rating. The pump should be sized to the home's domestic water load (5-9 gpm [19-34 l/m]) plus the heat pump water load. Discharge water from the unit is not contaminated in any manner and can be disposed of in various ways depending on local building codes; i.e. recharge well, storm sewer, drain field, adjacent stream or pond, etc. Most local codes forbid the use of sanitary sewer for disposal. Consult your local building and zoning department to assure compliance in your area.

Water Control Valve

Note the placement of the water control valve. Always maintain water pressure in the heat exchanger by placing water control valves at the outlet of the unit to prevent mineral precipitation. Pilot operated or Taco slow closing valve's solenoid valves are recommended to reduce water hammer. If water hammer persists, a mini-expansion tank can be mounted on the piping to help absorb the excess hammer shock. Insure that the total 'VA' draw of the valve can be supplied by the unit transformer. For instance the Taco slow closing valve can draw up to 35VA. This can overload smaller 40 or 50 VA transformers depending on the other controls employed. A typical pilot operated

solenoid valve draws approximately 15VA. Note the special wiring diagram of the AVM valve (Figure 9).

Flow Regulation

Flow regulation can be accomplished by two methods. First, most water control valves have a built in flow adjustment. By measuring the pressure drop through the unit heat exchanger, flow rate can be determined and compared to Table 7. Simply adjust the water control valve until the desired flow is achieved. Secondly, a flow control device may be installed. The devices are typically an orifice of plastic material that is designed to allow a specified flow rate. These are mounted on the outlet of the water control valve. On occasion, these valves can produce a velocity noise that can be reduced by applying some back pressure. This is accomplished by slightly closing the leaving isolation valve of the well water setup.

Low Temperature Cutout

The water low temperature cutout setpoint should be activated to avoid freeze damage to the unit. Consult the low temperature cutout section of the controls description for instructions.

▲ CAUTION! ▲

CAUTION! Many units are installed with a factory or field supplied manual or electric shut-off valve. **DAMAGE WILL OCCUR** if shut-off valve is **closed** during unit operation. A high pressure switch must be installed on the heat pump side of any field provided shut-off valves and connected to the heat pump controls in series with the built-in refrigerant circuit high pressure switch to disable compressor operation if water pressure exceeds pressure switch setting. The field installed high pressure switch shall have a cut-out pressure of 235 psig [1620 kPa] and a cut-in pressure of 190 psig [1310 kPa]. This pressure switch can be ordered with a 1/4" internal flare connection as part number 39B0005N01.

▲ CAUTION! ▲

CAUTION! Refrigerant pressure activated water regulating valves should never be used with this equipment.

GROUND-WATER HEAT PUMP SYSTEMS

Figure 2: Typical Open Loop/ Well Application.

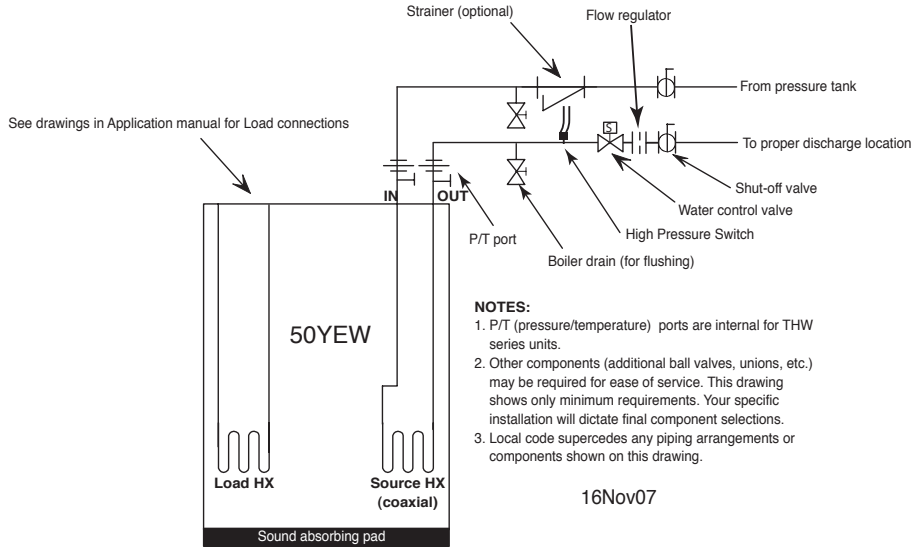

Table 2: Water Quality Standards

Water Quality Parameter	HX Material	Closed Recirculating	Open Loop and Recirculating Well
Scaling Potential - Primary Measurement			
Above the given limits, scaling is likely to occur. Scaling indexes should be calculated using the limits below.			
pH/Calcium Hardness Method	All	-	pH < 7.5 and Ca Hardness <100ppm
Index Limits for Probable Scaling Situations - (Operation outside these limits is not recommended)			
Scaling indexes should be calculated at 150°F [66°C] for direct use and HWG applications, and at 90°F [32°C] for indirect HX use. A monitoring plan should be implemented.			
Ryznar Stability Index	All	-	6.0 - 7.5 If >7.5 minimize steel pipe use.
Langelier Saturation Index	All	-	-0.5 to +0.5 If <-0.5 minimize steel pipe use. Based upon 150°F [66°C] HWG and Direct well, 85°F [29°C] Indirect Well HX
Iron Fouling			
Iron Fe ²⁺ (Ferrous) (Bacterial Iron potential)	All	-	<0.2 ppm (Ferrous) If Fe ²⁺ (ferrous)>0.2 ppm with pH 6 - 8, O ₂ <5 ppm check for iron bacteria
Iron Fouling	All	-	<0.5 ppm of Oxygen Above this level deposition will occur.
Corrosion Prevention			
pH	All	6 - 8.5 Monitor/treat as needed	6 - 8.5 Minimize steel pipe below 7 and no open tanks with pH <8
Hydrogen Sulfide (H ₂ S)	All	-	<0.5 ppm At H ₂ S>0.2 ppm, avoid use of copper and copper nickel piping or HX's. Rotten egg smell appears at 0.5 ppm level. Copper alloy (bronze or brass) cast components are OK to <0.5 ppm.
Ammonia ion as hydroxide, chloride, nitrate and sulfate compounds	All	-	<0.5 ppm
Maximum Chloride Levels	Maximum Allowable at maximum water temperature.		
			50°F (10°C) 75°F (24°C) 100°F (38°C)
	Copper	-	<20ppm NR NR
	CuproNickel	-	<150 ppm NR NR
	304 SS	-	<400 ppm <250 ppm <150 ppm
316 SS	-	<1000 ppm <550 ppm < 375 ppm	
Titanium	-	>1000 ppm >550 ppm >375 ppm	
Erosion and Clogging			
Particulate Size and Erosion	All	<10 ppm of particles and a maximum velocity of 6 fps [1.8 m/s]. Filtered for maximum 800 micron [800mm, 20 mesh] size.	<10 ppm (<1 ppm "sandfree" for reinjection) of particles and a maximum velocity of 6 fps [1.8 m/s]. Filtered for maximum 800 micron [800mm, 20 mesh] size. Any particulate that is not removed can potentially clog components.

Notes:
 • Closed Recirculating system is identified by a closed pressurized piping system.
 • Recirculating open wells should observe the open recirculating design considerations.
 • NR - Application not recommended.
 • "-" No design Maximum.

Rev.: 11/17/06D

GROUND-LOOP HEAT PUMP APPLICATIONS

Piping Installation

The typical closed loop ground source system is shown in Figure 3. All earth loop piping materials should be limited to only polyethylene fusion in inground sections of the loop. Galvanized or steel fitting should not be used at any time due to their tendency to corrode. All plastic to metal threaded fittings should be avoided due to their potential to leak in earth coupled applications and a flanged fitting substituted. P/T plugs should be used so that flow can be measured using the pressure drop of the unit heat exchanger in lieu of other flow measurement means. Earth loop temperatures can range between 25-110°F [-3.9 - 43.3°C]. Upon completion of the ground loop piping, pressure test the loop to assure a leak free system. Horizontal Systems: test individual loops as installed. Test entire system when all loops are assembled. Vertical U-Bends and Pond Loop Systems: test vertical U-bends and pond loop assemblies prior to installation with a hydrostatic test pressure of at least 100 psi [689 kPa].

Flushing the Earth Loop

Once piping is completed between the unit, flow center and the ground loop (Figure 3), final purging and charging of the loop is needed. A flush cart (at least a 1.5 hp [1.1 kW] pump) is needed to achieve adequate flow velocity in the loop to purge air and dirt particles from the loop itself. An antifreeze solution is used in most areas to prevent freezing. All air and debris must be removed from the earth loop piping system before operation. Flush the loop with a high volume of water at a high velocity (2 fps [0.6 m/s] in all piping) both directions. The steps below must be followed for proper flushing. Fill loop with water from a garden hose through flush cart before using flush cart pump to ensure an even fill. Once full, do not allow the water level in the flush cart tank to drop below the pump inlet line or air can be pumped back out to the earth loop. Try to maintain a fluid level in the tank above the return tee so that air can not be continuously mixed back into the fluid. 50 psi [345 kPa] surges can be used to help purge air pockets by simply shutting off the return valve going into the flush cart reservoir. This 'dead heads' the pump to 50 psi [345 kPa]. To dead head the pump until maximum pumping pressure is reached, open the valve back up and a pressure surge will be sent through the loop to help purge air pockets from the piping system. Notice the drop in fluid level in the flush cart tank. **If air is purged from the system, the level will drop only 1-2 [25-50mm] inches in a 10" [254mm] diameter PVC flush tank (about a half gallon) since liquids are incompressible.** If the level drops more than this, flushing should continue since air is still being compressed in the loop fluid. Do this a number of times.

When the fluid level drops less than 1-2" [25-50mm] in a 10" [254mm] diameter tank the flow can be reversed. Finally the dead head test should be checked again for an indication of air in the loop. **This fluid level drop is your only indication of air in the loop.**

Table 3: Approximate Fluid Volume (gal.) per 100' of Pipe

Fluid Volume (gal [liters] per 100' [30 meters) Pipe)		
Pipe	Size	Volume (gal) [liters]
Copper	1"	4.1 [15.3]
	1.25"	6.4 [23.8]
	2.5"	9.2 [34.3]
Rubber Hose	1"	3.9 [14.6]
Polyethylene	3/4" IPS SDR11	2.8 [10.4]
	1" IPS SDR11	4.5 [16.7]
	1.25" IPS SDR11	8.0 [29.8]
	1.5" IPS SDR11	10.9 [40.7]
	2" IPS SDR11	18.0 [67.0]
	1.25" IPS SCH40	8.3 [30.9]
	1.5" IPS SCH40	10.9 [40.7]
	2" IPS SCH40	17.0 [63.4]
Unit Heat Exchanger	Typical	1.0 [3.8]
Flush Cart Tank	10" Dia x 3ft tall [254mm x 91.4cm tall]	10 [37.9]

Table 4: Antifreeze Percentages by Volume

Type	Minimum Temperature for Low Temperature Protection			
	10°F [-12.2°C]	15°F [-9.4°C]	20°F [-6.7°C]	25°F [-3.9°C]
Methanol	25%	21%	16%	10%
100% USP food grade Propylene Glycol	38%	25%	22%	15%
Ethanol*	29%	25%	20%	14%

* Must not be denatured with any petroleum based product

GROUND-LOOP HEAT PUMP APPLICATIONS

Antifreeze may be added before, during, or after the flushing procedure. However, depending upon which time is chosen, antifreeze could be wasted when emptying the flush cart tank. See antifreeze section for more details. Loop static pressure will fluctuate with the seasons. Pressures will be higher in the winter months than during the cooling season. This fluctuation is normal and should be considered when charging the system initially. Run the unit in either heating or cooling for a number of minutes to condition the loop to a homogenous temperature. This is a good time for tool cleanup, piping insulation etc. Then final flush and pressurize the loop to a static pressure of 40-50 psi [275-345 kPa] (winter) 15-20 psi [100-138 kPa] (summer).

After pressurization, be sure to remove the plug in the end of the Grundfos loop pump motor(s) to allow trapped air to be discharged and to insure the motor housing has been flooded. This is not required for Taco circulators. Insure the loop flow center provides adequate flow through the unit by checking pressure drop across the heat exchanger and comparing it to the figures shown in Table 7.

Antifreeze

In areas where minimum entering loop temperatures drop below 40°F [4.4°C] or where piping will be routed through

areas subject to freezing, antifreeze is needed. Alcohols and glycols are commonly used as antifreezes, however your local territory manager should be consulted for the antifreeze best suited to your area. Freeze protection should be maintained to 15°F [-9.4°C] below the lowest expected entering loop temperature. For example, if 30°F [-1.1°C] is the minimum expected entering loop temperature, the leaving loop temperature would be 25-22°F [-3.9 to -5.6°C] and freeze protection should be at 15°F [-9.4°C] (30°F-15°F=15°F). All alcohols should be premixed and pumped from a reservoir outside of the building when possible or introduced under water level to prevent fuming. Initially calculate the total volume of fluid in the piping system using Table 3. Then use the percentage by volume shown in Table 4 for the amount of antifreeze. Antifreeze concentration should be checked from a well mixed sample using a hydrometer to measure specific gravity.

Low Water Temperature Cut-Out Setting

When an antifreeze is selected the low temperature limit setpoint should be switched to the lower setting to avoid nuisance faults. Consult **Low Water Temperature Cut-Out Setting** in the controls section for more information.

Figure 3: Typical Earth Loop Connection.

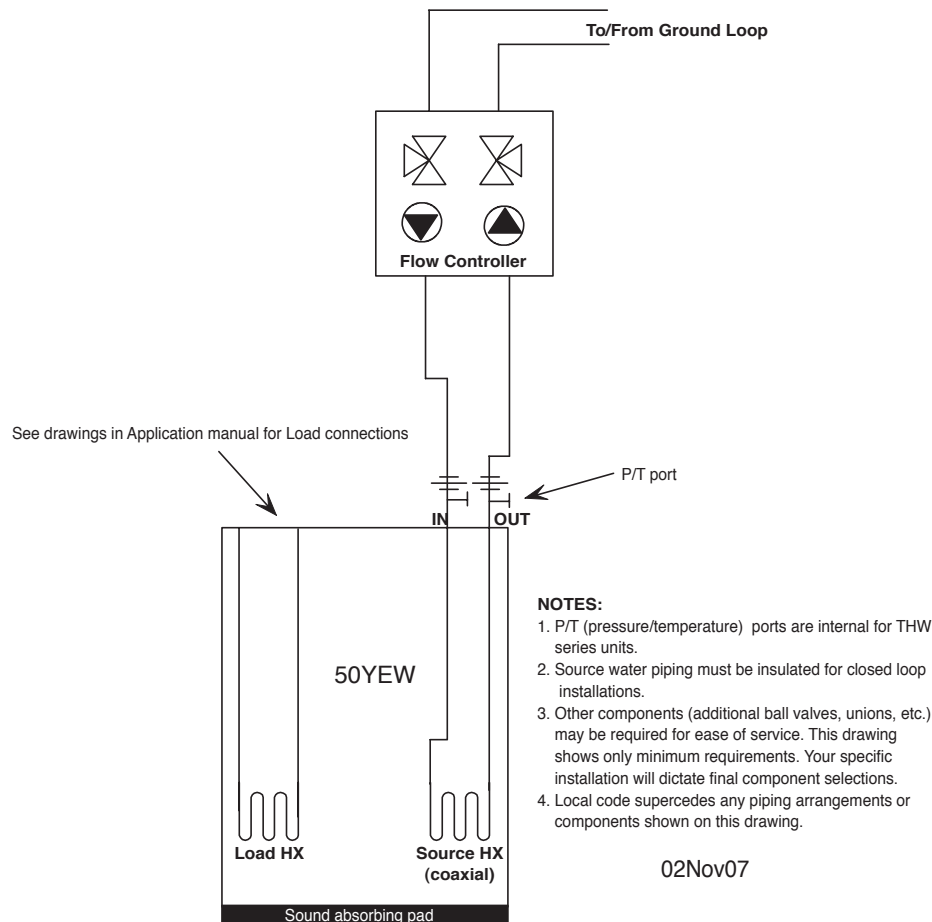

ELECTRICAL - LINE VOLTAGE

⚠ WARNING! ⚠

WARNING! To avoid possible injury or death due to electrical shock, open the power supply disconnect switch and secure it in an open position during installation.

⚠ WARNING! ⚠

WARNING! To avoid possible injury or death due to electrical shock, open the power supply disconnect switch and secure it in an open position during installation.

⚠ CAUTION! ⚠

CAUTION! Use only copper conductors for field installed electrical wiring. Unit terminals are not designed to accept other types of conductors.

50YEW Power Connection

Line voltage connection is made by connecting the incoming line voltage wires to the power block as shown in Figures 5 and 6. Consult Table 5 for correct fuse size.

All field installed wiring, including electrical ground, must comply with the National Electrical Code as well as all applicable local codes.

Refer to the unit wiring diagrams for fuse sizes and a schematic of the field connections which must be made by the installing (or electrical) contractor.

Consult the unit wiring diagram located on the inside of the compressor access panel to ensure proper electrical hookup.

All final electrical connections must be made with a length of flexible conduit to minimize vibration and sound transmission to the building.

General Line Voltage Wiring

Be sure the available power is the same voltage and phase as that shown on the unit serial plate. Line and low voltage wiring must be done in accordance with local codes or the National Electric Code, whichever is applicable.

208 Volt Operation

All 208-240 Volt units are factory wired for 240 Volt. The transformers may be switched to 208V operation as illustrated on the wiring diagram. By switching the Red (208V) and the Orange (240V) at the terminal.

Table 5: Electrical Data

Model	Voltage Code	Voltage	Min/Max Voltage	Compressor			Load Pump FLA	Source Pump (1) FLA	Source Pump (2) FLA	Total Unit FLA	Min Circuit Amps	Max Fuse HACR
				Qty	RLA	LRA						
50YEW010	3	208-230/60/1	197/254	1	20.7	81	-	-	-	20.7	25.9	45
							1.07	-	-	21.8	26.9	45
							1.07	1.07	1.07	23.9	29.1	45

Three Phase units require a neutral wire.

ELECTRICAL - LINE VOLTAGE

Figure 6: 50YEW 60Hz Line and Low Voltage

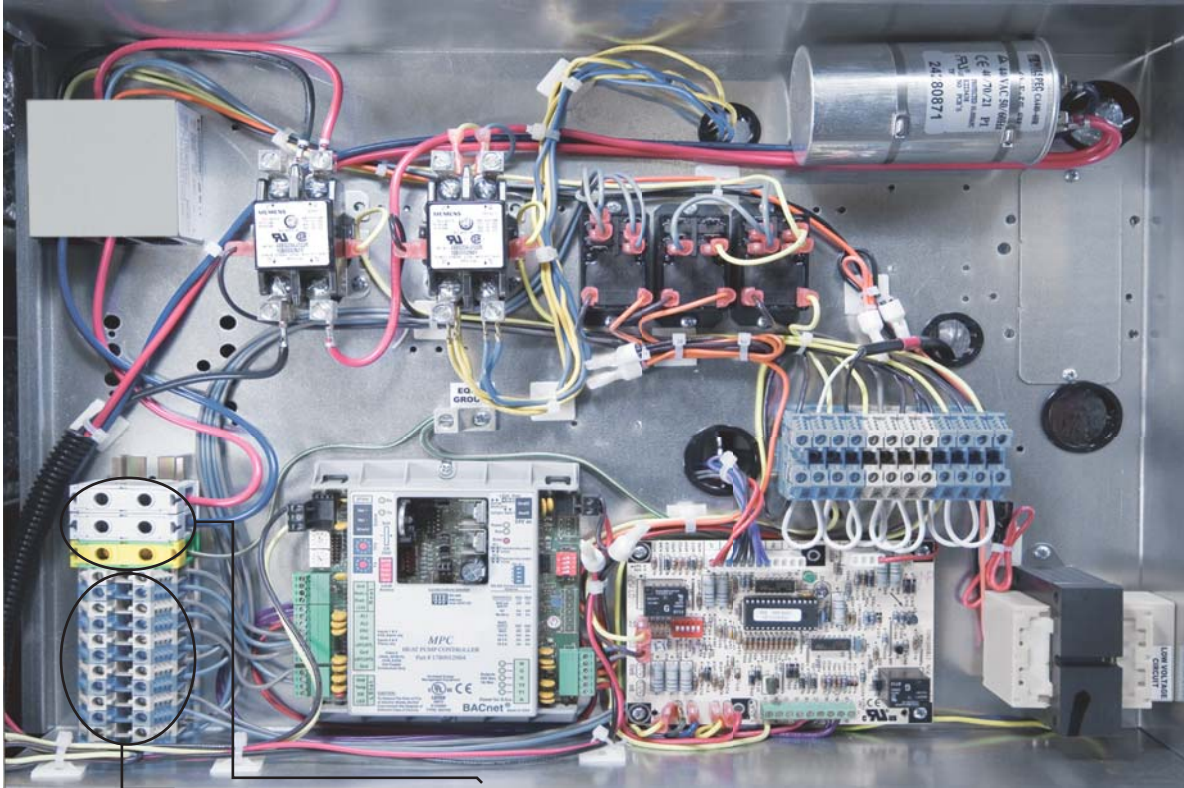

Field Low Voltage Wiring

Field Line Voltage Wiring

ELECTRICAL - LOW VOLTAGE

Low Voltage Connections

The thermistors (sensors) and other low voltage wiring should be connected to the 12 position terminal strip in the 50YEW control box. See figures 5 and 6 for details.

Low Water Temperature Cutout - FP1

The CXM/DXM control allows the field selection of source fluid low temperature cutout points. The factory setting of FP1 is set for water (30°F [-1.1°C]). In cold temperature applications jumper JW3 (FP1- antifreeze 10°F [-12.2°C]) should be clipped as shown in Figure 7 to change the setting to 10°F [-12.2°C], a more suitable temperature when using antifreezes.

Figure 7: Changing FP1-Low Water Temperature Cutout Setpoint

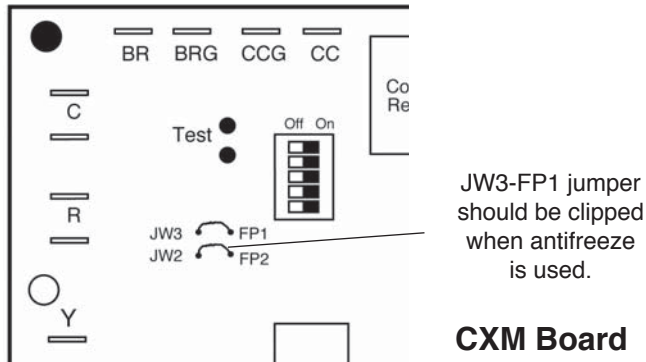

Accessory Connections

A terminal paralleling the compressor contactor coil has been provided on the CXM/DXM control of the 50YEW unit. "A" has been provided to control accessory devices, such as water valves, electronic air cleaners, humidifiers, etc. **Note: This terminal should be used only with 24 Volt signals and not line voltage signals.** This signal operates with the compressor contactor. See Figure 8 or the wiring schematic for details.

Figure 8: Accessory Wiring

Terminal Strip

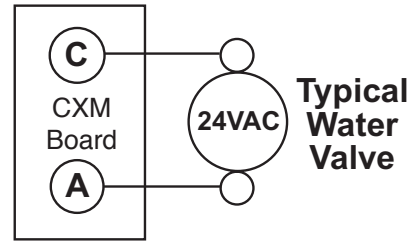

Water Solenoid Valves

Figures 9a and 9b illustrate a typical slow closing water control valve wiring. A slow closing valve may be required to prevent water hammer. When using an AVMB -Taco Slow Closing valves on 50YEW Series equipment Figure 9a wiring should be utilized. The valve takes approximately 60 seconds to open (very little water will flow before 45 seconds) and it activates the compressor only after the valve is completely opened (by closing its end switch). Only relay or triac based electronic thermostats should be used with the AVMB valve. When wired as shown, the valve will operate properly with the

1. The valve will remain open during a unit lockout.
2. The valve will draw approximately 25-35 VA through the "Y" signal of the thermostat.

ELECTRICAL - LOW VOLTAGE

Figure 9a: Well Water AVMB Valve Wiring

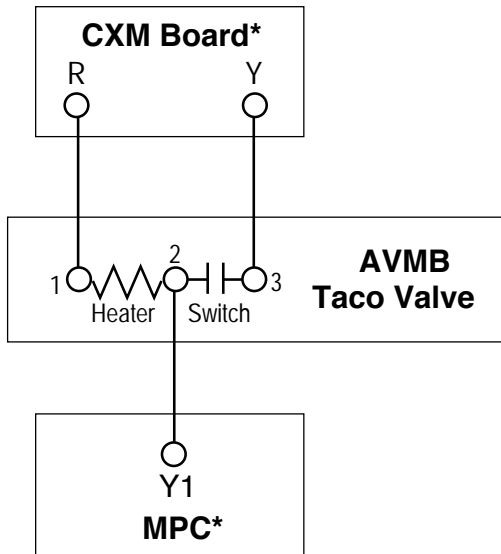

*Valve must be wired in between the CXM and MPC boards. Remove the yellow wire from the CXM board and connect it to terminal 2 on the valve. Add a new wire from terminal 3 to the Y terminal at the CXM board, and a jumper wire from terminal 1 to terminal R at the CXM board as shown above.

Figure 9b: Taco SBV Valve Wiring

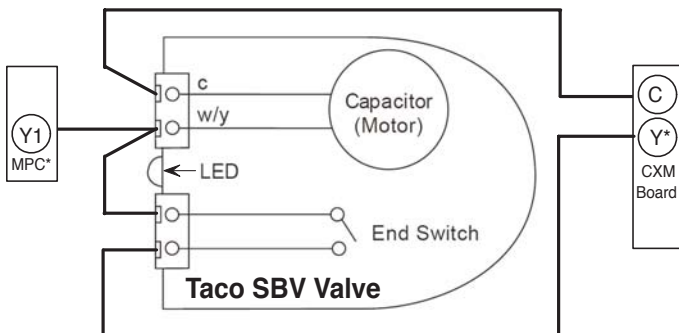

*Valve must be wired in between the CXM and MPC boards. Remove the yellow wire from the CXM board and connect it to the w/y terminal on the valve. Add a new wire from the end switch (bottom connection) to the the Y terminal at the CXM board, and a jumper wire from the w/y terminal to the other side (top connection) of the end switch as shown above.

⚠ CAUTION! ⚠

CAUTION! Many units are installed with a factory or field supplied manual or electric shut-off valve. **DAMAGE WILL OCCUR** if shut-off valve is **closed** during unit operation. A high pressure switch must be installed on the heat pump side of any field provided shut-off valves and connected to the heat pump controls in series with the built-in refrigerant circuit high pressure switch to disable compressor operation if water pressure exceeds pressure switch setting. The field installed high pressure switch shall have a cut-out pressure of 235 psig [1620 kPa] and a cut-in pressure of 190 psig [1310 kPa]. This pressure switch can be ordered with a 1/4" internal flare connection as part number 39B0005N01.

⚠ CAUTION! ⚠

CAUTION! Refrigerant pressure activated water regulating valves should never be used with this equipment.

ELECTRICAL - CONTROLS

Controls

User interface: Figure 10 shows the factory installed and wired panel-mounted user interface for customizing the MPC programming. A large dot-matrix style 2" x 2" [5 x 5 cm] back-lit display is controlled by four arrow keys and a select key. The main screen, as shown in figure 11, displays current outdoor and water temperatures, and allows the user to change settings by selecting one of the menus from the bottom of the screen (see figure 13 50YEW User Interface Menu). A special installer set up mode allows the technician to change some of the default MPC parameters. The installer menu may only be accessed when the unit is placed in the off mode. Holding the up and down buttons at the same time will cause the interface to enter the installer setup mode. See figure 14 (interface installer menu) The user interface includes a time schedule for DHW generation, Fahrenheit/Celsius selection, vacation mode for DHW, and other user preference options.

Figure 10: 50YEW User Interface

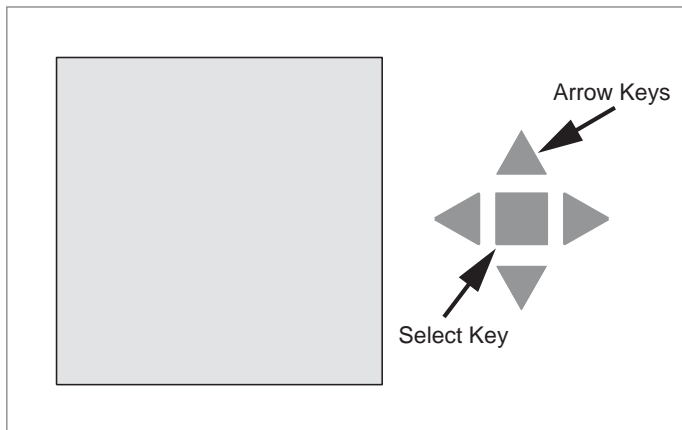
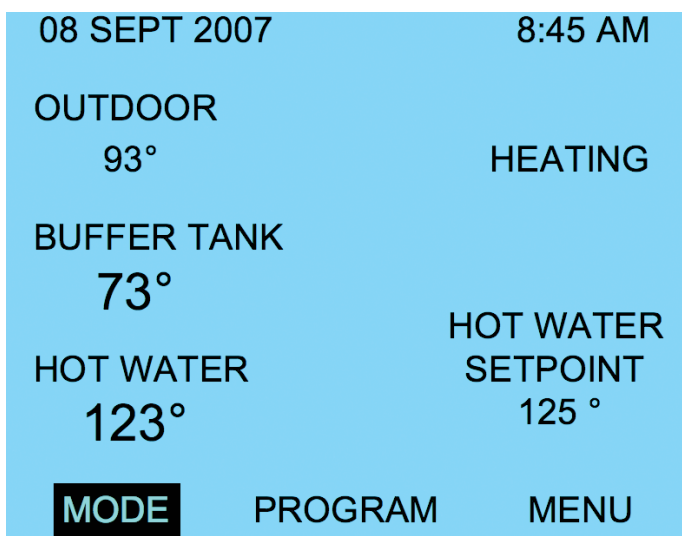

Figure 11: 50YEW User Interface Main Screen



50YEW Series Control Features

The advantage of a programmable controller, as outlined above, is the ability to integrate complex decision-making tasks with the standard heat pump (CXM) controls and communicate with a user interface. Below is a list of standard features that are included in the 50YEW series controls.

⚠ CAUTION! ⚠

CAUTION: Maximum leaving water temperature of the 50YEW series equipment is 145°F [63°C]. For domestic hot water tank temperatures or heating buffer tank temperatures above 130°F [54°C], pump and pipe sizing is critical to insure that the flow rate through the heat pump is sufficient to maintain leaving water temperatures below the maximum temperature, and to provide water flow rates within the ranges shown in the performance section of this manual.

Outdoor temperature reset: The heat pump capacity and water temperature delivery to the heating system must be designed for local weather conditions, usually at the 99.6% outdoor temperature. Therefore, 99.6% of the heating season, the heating load is less than it is at design conditions. As the outdoor temperature decreases, the heat loss of the structure increases, which requires more capacity from the heating system. If the water temperature is reduced as the outdoor air temperature increases (and vice-versa), the heat pump operates at higher COP most of the year. The MPC has a built in algorithm that adjusts the buffer tank temperature based upon outdoor air temperature to maximize efficiency and comfort. Temperature settings may be adjusted at the user interface if factory defaults are not sufficient.

The base setpoint for energizing the compressor in the heating mode is determined by subtracting one-half the heating differential value (HTD) from the buffer tank heating temperature setpoint. The HTD is the differential used for controlling setpoint. For example, if the buffer tank setpoint is 100°F [38°C], and the HTD is 6°F [3°C], the compressor will be energized at 97°F [36°C] and will be turned off at 103°F [39°C]. The HTD is the difference between the compressor "call" (97°F [36°C]) and the "satisfied" (103°F [39°C]) temperature. The buffer tank temperature may then be reduced by the outdoor temperature reset function, depending on the current outdoor air temperature (OAT) value. The valid range for the buffer tank heating setpoint is 70-140°F [21-60°C], with a default value of 100°F [38°C]. The valid range for the heating differential value (HTD) is 4-20°F [2-11°C], adjustable in 2°F [1°C] increments, with a default value of 6°F [3°C].

ELECTRICAL - CONTROLS

There are four outdoor reset variables used for reducing the buffer tank setpoint. The outdoor design temperature (ODT) is the OAT above which setpoint reduction begins. The valid range for ODT is -40°F to 50°F [-40°C to 10°C], with a default value of 0°F [-18°C]. The maximum design buffer tank temperature (MaxBT) is the maximum desired buffer tank setpoint at the outdoor design temperature. The valid range for MaxBT is $80-140^{\circ}\text{F}$ [$27-60^{\circ}\text{C}$], with a default value of 130°F [54°C]. The building balance point temperature (the temperature at which heating is no longer needed) is the OAT at which maximum setpoint (MaxBT) reduction will occur. The valid range for building balance point is $50-70^{\circ}\text{F}$ [$10-21^{\circ}\text{C}$], with a default value of 60°F [16°C]. The minimum design water temperature is

the minimum desired buffer tank setpoint at the building balance point temperature. The valid range for minimum buffer tank temperature is $70^{\circ}\text{F}-120^{\circ}\text{F}$ [$21-49^{\circ}\text{C}$], with a default value of 70°F [21°C]. If an OAT sensor is not detected (or if a thermistor error has occurred), the buffer tank setpoint will not be reduced based on the OAT value (i.e. the controller will use the buffer tank setpoint as described in the previous paragraph).

Figure 12 shows an example outdoor temperature reset curve for a climate that has an outdoor design temperature of -4°F [-20°C]. At design temperature, the radiant floor system needs 126°F [52°C] water. However, when the outdoor temperature is 68°F [20°C], the home needs no heating (building balance point). In between -4°F and 68°F [-20°C and 20°C], the water temperature in the buffer tank is adjusted accordingly. For homes that are well insulated and tightly sealed, the building balance point may be 55°F [13°C] or lower, so the slope of the line changes based upon settings at the user interface. The radiant floor design temperature will also change the slope of the line. If tighter pipe spacing is used, for example, the water temperature at the outdoor design temperature may only be 100°F [38°C]. Again, as the settings are changed at the user interface, the slope of the line will change. As mentioned earlier, the lower the heating water temperature at design conditions, the higher the efficiency (COP) of the heat pump. The combination of a lower design temperature and outdoor temperature reset can result in a significant impact on operating costs.

Table 6: Buffer Tank Interface Inputs

Setting Description	Range	Default
Buffer Tank Set Point	70-140°F [21-60°C]	100°F [38°C]
Buffer Tank Deadband	4-20°F [2-11°C]	6°F [3°C]
Outdoor Design Temp	-40-50°F [-40-10°C]	0°F [-18°C]
Maximum Design Water Temp	80-140°F [27-60°C]	130°F [54°C]
Minimum Design Water Temp	70-120°F [21-49°C]	70°F [21°C]
Building Balance Point Temp	50-70°F [10-21°C]	60°F [16°C]

The maximum design water temperature must be equal the buffer tank setpoint. The buffer tank setpoint will override the maximum design temperature if they are entered with different values.

Figure 12: Example Outdoor Temperature Reset

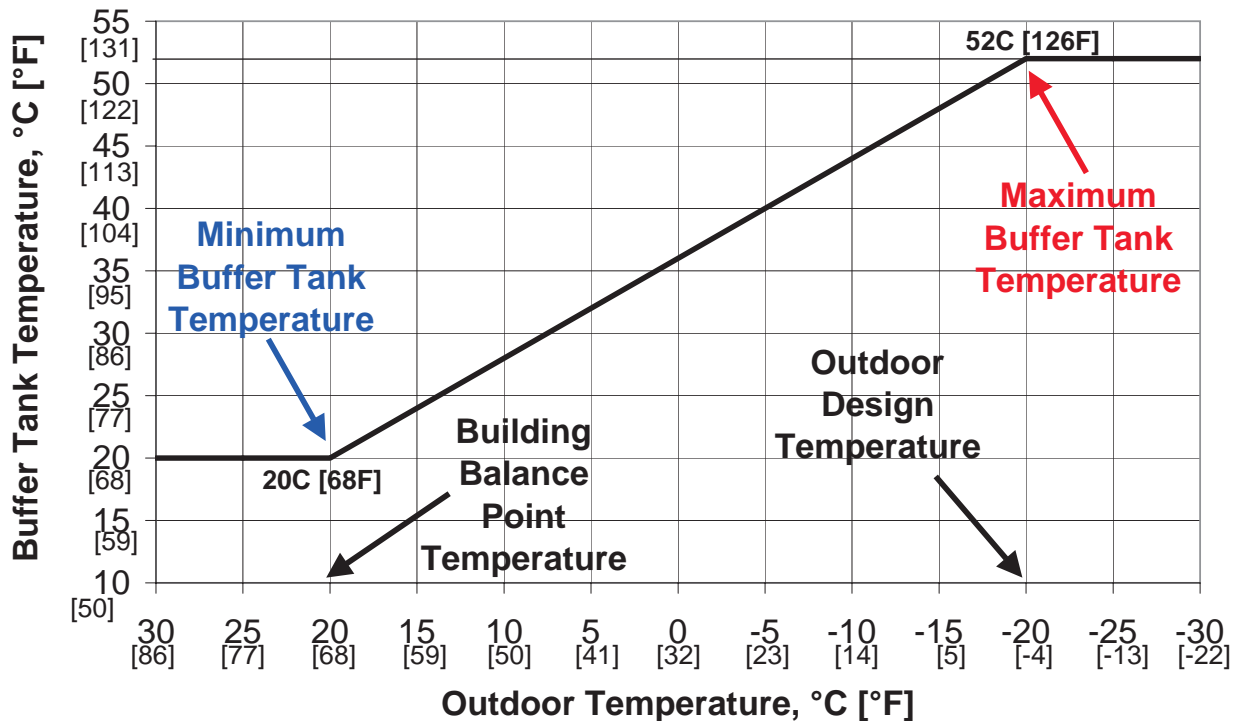

ELECTRICAL - CONTROLS

Warm weather shutdown (WWSD): Radiant floor systems are the most comfortable type of heating available today. However, they do have one disadvantage – quickly switching from heating to cooling is not possible due to the mass heat storage in the slab. For example, in the spring or fall, there could be times where heating is required at night, but cooling is required during the day. With a warm floor, the cooling system has to work much harder to cool the space. WWSD shuts down the water-to-water heat pump at a pre-determined outdoor air temperature (adjustable at the user interface). When a water-to-air heat pump is used for space cooling, this unit can be enabled when WWSD is activate, allowing the water-to-air heat pump to heat via forced air during the shoulder seasons, avoiding the warm slab/cooling dilemma (see cooling enable, below). A normally closed contact is provided in the 50YEW unit to de-energize the heating system controls (e.g. radiant floor control panel) during WWSD. WWSD does not affect DHW heating. In other words, the water-to-water unit can still operate for generating DHW, even if the heating distribution (e.g. radiant floor) system is disabled.

The WWSD activation (i.e. when the WWSD feature is enabled) outdoor air temperature range is 40-100°F [4-38°C] with a default value of 70°F [21°C]. The WWSD deactivation (i.e. when the radiant heating returns to operating mode) temperature range is 35-95°F [2-35°C] with a default value of 65°F [18°C] and a minimum difference between activation and deactivation temperatures of 5°F [3°C]. If the outdoor air temperature (OAT) rises above the activation temperature, the cooling enable signal (see below) is enabled, and the control no longer controls the buffer tank temperature. If the OAT falls below the deactivation temperature, the control resumes monitoring the buffer tank temperature.

Cooling enable: Cooling enable is tied to the WWSD feature. If desired, the water-to-air unit controls can be wired to the 50YEW unit controls, which will allow the water-to-air unit to operate during WWSD, but will disable the water-to-air unit when the 50YEW unit is not in WWSD mode. When a heat pump thermostat is connected to the water-to-air unit, forced air heating may be used for the shoulder seasons, allowing quick heating to cooling changeover. If this feature is used, the consumer will easily be able to tell when WWSD is enabled because the water-to-air unit thermostat will only be active during WWSD. Otherwise, the water-to-air unit thermostat will be disabled, indicating that the consumer should utilize the hydronic heating (e.g. radiant floor) thermostat.

Second stage heating (backup boiler): Optimal heat pump sizing may not include a water-to-water heat pump that can handle 100% of the heating load. When a backup boiler is used to supplement the heating capacity, a 24VAC output from the 50YEW unit can energize the boiler. The boiler control box simply needs a relay that can be used to interface with the 50YEW unit.

DHW priority: By default, DHW heating always takes priority over space heating. Normally, the hot water load will be satisfied quickly, and the unit can then switch back to space heating.

Time schedule: DHW temperatures may be adjusted during occupied/unoccupied times via the user interface to save energy costs.

Vacation mode: DHW generation may be disabled when the user interface is placed in vacation mode. A return date and time may be set to restore normal DHW temperatures.

Emergency DHW generation: If the 50YEW unit is locked out, a 24VAC signal can be sent to a contactor at the water heater to allow the operation of the electric elements and associated thermostat.

Enhanced heat pump lockouts: The CXM board locks out the compressor any time a lockout condition occurs. The MPC reads the lockouts from the CXM, and reports the condition to the user interface. The user interface changes from a blue backlight to a red backlight, indicating a lockout. The actual lockout is reported (e.g. High Pressure) at the interface. In addition to the standard CXM faults, the MPC checks for bad thermistors and high compressor discharge temperature, which are also reported at the user interface.

Pump control: If the optional load and source pump(s) are selected, the control energizes the pumps any time the compressor is operating.

Variable speed floor pump (VSFP) output: Some radiant floor systems utilize a variable speed pump on the floor system, which changes flow based upon the number of zones open or closed. Since the pump has built-in controls, only a power supply is needed. An optional power terminal is available for VSFP applications.

ELECTRICAL - CONTROLS

Figure 13: 50YEW User Interface Menu

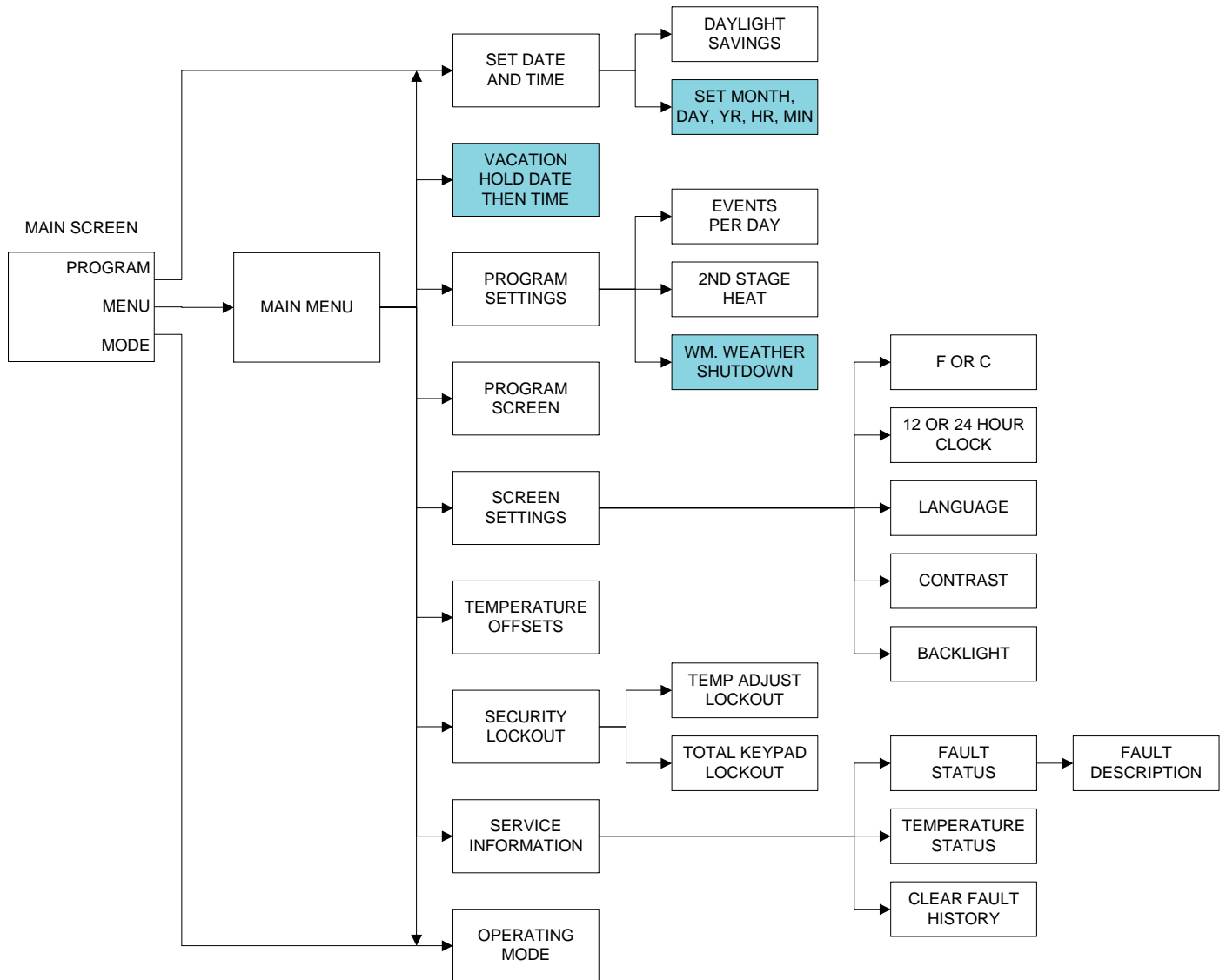

ELECTRICAL - CONTROLS

Figure 14: 50YEW Interface Installer Menu

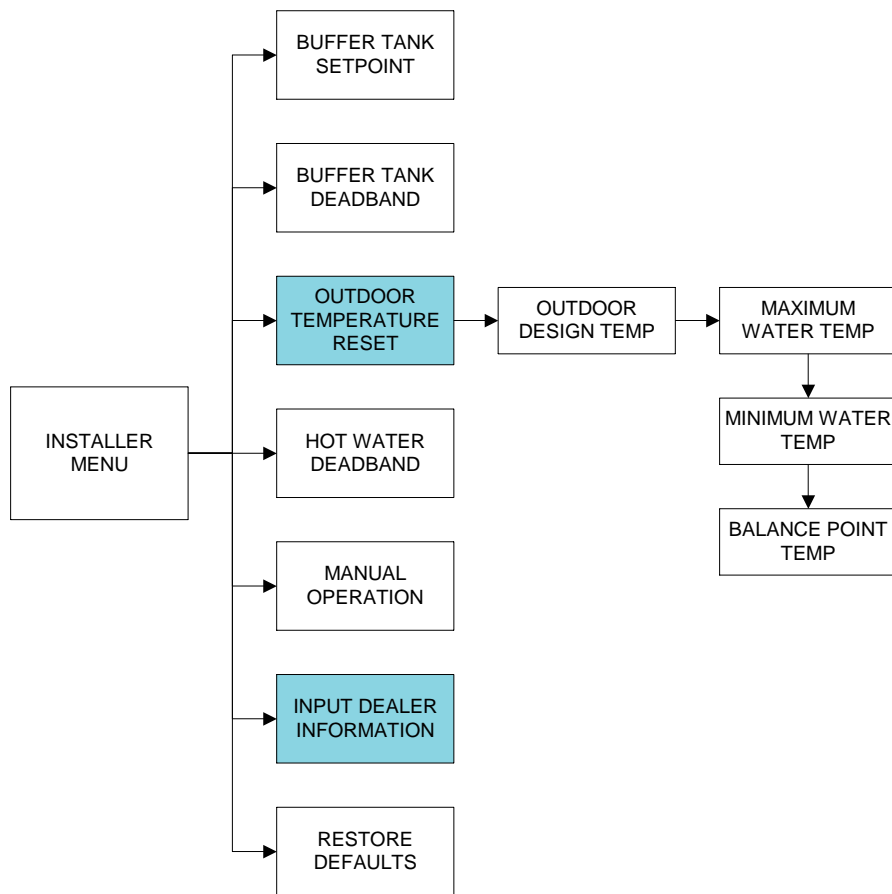

ELECTRICAL - WIRING DIAGRAM MATRIX

Model	Diagram Number	Voltage	Option
50YEW010	96B0108N05	230/60/1	-
50YEW010	96B0108N06	230/60/1	VSFP

TYPICAL WIRING DIAGRAM - 50YEW 230/60/1 UNITS

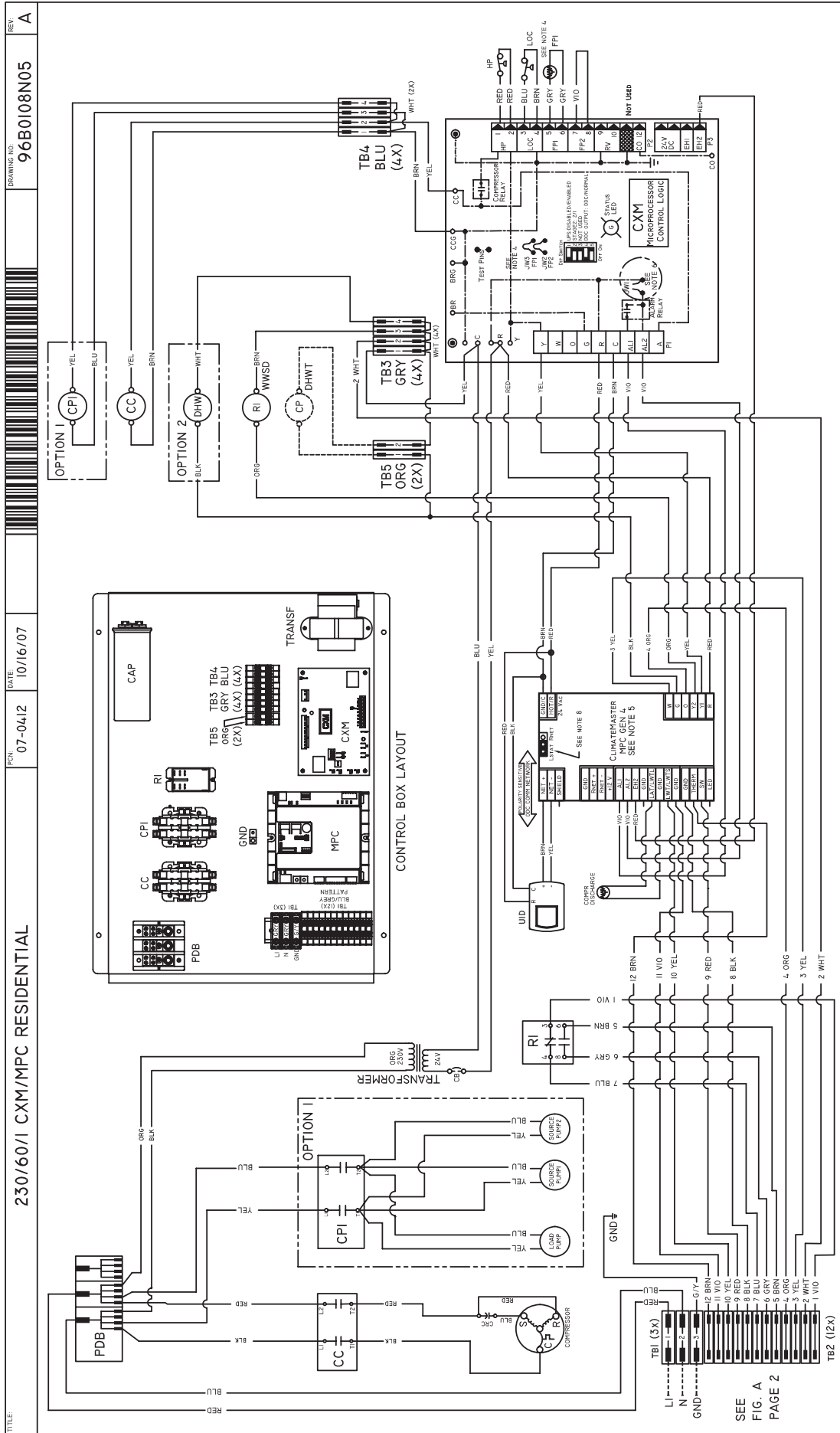

REV: A
DRAWING NO: 96B0108N05



PCN: 07-0412
DATE: 10/16/07

TITLE: 230/60/1 CXM/MPC RESIDENTIAL

TYPICAL WIRING DIAGRAM - 50YEW 230/60/1 UNITS

FILE:	TITLE:	DRAWING NO:	REV:		
230/60/1 CXM/MPC RESIDENTIAL	230/60/1 CXM/MPC RESIDENTIAL	96B0108N05	A		
<p>LEGEND</p> <p>FACTORY LOW VOLTAGE WIRING</p> <p>FIELD LINE VOLTAGE WIRING</p> <p>OPTIONAL WIRING</p> <p>ALARM WIRING</p> <p>CONDENSATE FAN</p> <p>CIRCUIT BREAKER</p> <p>GROUND</p> <p>OPTIONAL</p> <p>COMMON POINT</p>	<p>ALARM RELAY CONTACTS</p> <p>AQUA STAT</p> <p>COMMON</p> <p>COMPRESSOR RUN CAPACITOR</p> <p>COMPRESSOR CONTACTOR</p> <p>COMPRESSOR PUMP</p> <p>DHW TANK AQUASTAT</p> <p>DHW TANK THERMISTOR</p> <p>DISCONNECT SWITCH</p> <p>ELECTRIC HEAT (DHW)</p> <p>ESSENTIAL FLOOR 24VAC INTERRUPT</p> <p>LOW TEMP PROTECTION BAILE FLAT</p> <p>GROUND</p> <p>HIGH PRESSURE SWITCH</p> <p>JUMPER WIRE</p> <p>MPC CONTROLLER</p> <p>MANUAL STARTER</p>	<p>RELAY CONTACTS - N.C.</p> <p>RELAY CONTACTS - N.O.</p> <p>CAPACITOR</p> <p>TEMPERATURE SWITCH</p> <p>LOW PRESSURE SWITCH</p> <p>HIGH PRESSURE SWITCH</p> <p>OVERLOAD</p> <p>COIL</p> <p>LED</p>	<p>NOTES:</p> <p>1. COMPRESSOR THERMALLY PROTECTED INTERNALLY.</p> <p>2. ALL WIRING TO THE UNIT MUST COMPLY WITH CE AND LOCAL CODES.</p> <p>3. 208/230V TRANSFORMER WILL BE CONNECTED FOR 230V OPERATION. FOR 208V OPERATION, THE WIRING WILL BE CONNECTED TO THE 208V SECONDARY WINDING. INSULATE OPEN END OF ORIG LEAD.</p> <p>4. FRI THERMISTOR PROVIDES LOW TEMPERATURE PROTECTION FOR WATER. WHEN USING ANTI-FREEZE SOLUTIONS, CUT JMS JUMPER.</p> <p>5. MANUAL FOR CONTROL WIRING TO THE UNIT. LOW VOLTAGE WIRING MUST BE CLASS "F" AND VOLTAGE RATED EQUAL OR GREATER THAN UNIT SUPPLY VOLTAGE.</p> <p>6. FACTORY COIL (CMT) OR (IDM) JUMPER. ONLY CONTACT WILL BE AVAILABLE BETWEEN ALI AND ALZ.</p> <p>7. TRANSFORMER SECONDARY GROUND VIA C/M/DMX BOARD STANDOFFS & SCREWS TO EXISTING SECONDARY GROUND. LOCATED IN WATER-TO-AIR UNIT.</p> <p>8. USE RELAY WITH TWO N.C. CONTACTS FOR TWO-STAGE UNITS (BREAK 1 Y2).</p>	<p>CMX CONTROLLER FAULT CODES</p> <p>DESCRIPTION OF OPERATION</p> <p>NORMAL MODE</p> <p>ALARM RELAY</p> <p>CMX IS NON-FUNCTIONAL</p> <p>FAULT RETRY</p> <p>OVER/UNDER VOLTAGE SHUTDOWN</p> <p>TEST MODE-NO FAULT IN MEMORY</p> <p>TEST MODE-FRI FAULT IN MEMORY</p> <p>TEST MODE-FRI FAULT IN MEMORY</p> <p>TEST MODE-CP FAULT IN MEMORY</p> <p>TEST MODE-OVER/UNDER SHUTDOWN IN MEMORY</p> <p>TEST MODE-TEMP FAULT IN MEMORY</p> <p>SWAPPED THERMISTOR LOCKOUT</p>	<p>DESCRIPTION</p> <p>OUTDOOR AIR THERMISTOR CONNECTION</p> <p>BUFFER TANK THERMISTOR CONNECTION</p> <p>WATER HEATER TANK THERMISTOR CONNECTION</p> <p>RADIANT FLOOR 24VAC INTERRUPT (TERMINALS 1 & 7) -- WWSD</p> <p>24VAC SIGNAL TO COOLING UNIT</p> <p>24VAC SIGNAL TO COOLING THERMOSTAT</p> <p>24VAC SIGNAL TO ENABLE BACKUP BOILER OR 2ND STAGE HEATING</p> <p>24VAC SIGNAL TO ENABLE OPTIONAL EMERGENCY ELECTRIC WATER HEATER</p> <p>COMMON FLOOR EXTERNAL RELAY COILS</p> <p>RADIANT FLOOR 24VAC INTERRUPT (TERMINALS 1 & 7) -- WWSD</p>

TERMINAL	LABEL	DESCRIPTION
12	O/A	OUTDOOR AIR THERMISTOR CONNECTION
10	B1/OA	BUFFER TANK THERMISTOR CONNECTION
9	B/W	WATER HEATER TANK THERMISTOR CONNECTION
8	D/W	WATER HEATER TANK THERMISTOR CONNECTION
7	F	RADIANT FLOOR 24VAC INTERRUPT (TERMINALS 1 & 7) -- WWSD
6	R/U	24VAC SIGNAL TO COOLING UNIT
5	R/T	24VAC SIGNAL TO COOLING THERMOSTAT
4	W/Z	24VAC SIGNAL TO ENABLE BACKUP BOILER OR 2ND STAGE HEATING
3	E/H	24VAC SIGNAL TO ENABLE OPTIONAL EMERGENCY ELECTRIC WATER HEATER
2	C	COMMON FLOOR EXTERNAL RELAY COILS
1	F	RADIANT FLOOR 24VAC INTERRUPT (TERMINALS 1 & 7) -- WWSD

INPUT#	INPUT NAME (SILK SCREEN)	INPUT FUNCTION (PROGRAM)	ANALOG SIGNAL	DIGITAL SIGNAL
1	ALI & ALZ	LOCKOUT ALARM	NO	YES
2	EHZ/GND	PULSE CODE SIGNAL	NO	YES
3	LAT/LWT/L & GND	CMR DISCHARGE TEMP	YES	NO
4	LWT/LWTS & GND	BUFFER TANK TEMP SENSOR	YES	NO
5	GND & THERM	OAT	YES	NO
6	GND & SW	DHWS	YES	NO

OUTPUT#	OUTPUT NAME (SILK SCREEN)	OUTPUT NAME (PROGRAM)
1	Y1	COMPRESSOR/S&L PUMPS
2	Y2	WWSD
3	O	2ND STAGE HEATING
4	G	3-WAY VALVE (DHW)
5	W	EMERGENCY DHW

SEE APPLICATION MANUAL FOR FIELD WIRING

TYPICAL WIRING DIAGRAM - 50YEW 230/60/1 UNITS WITH VSFP

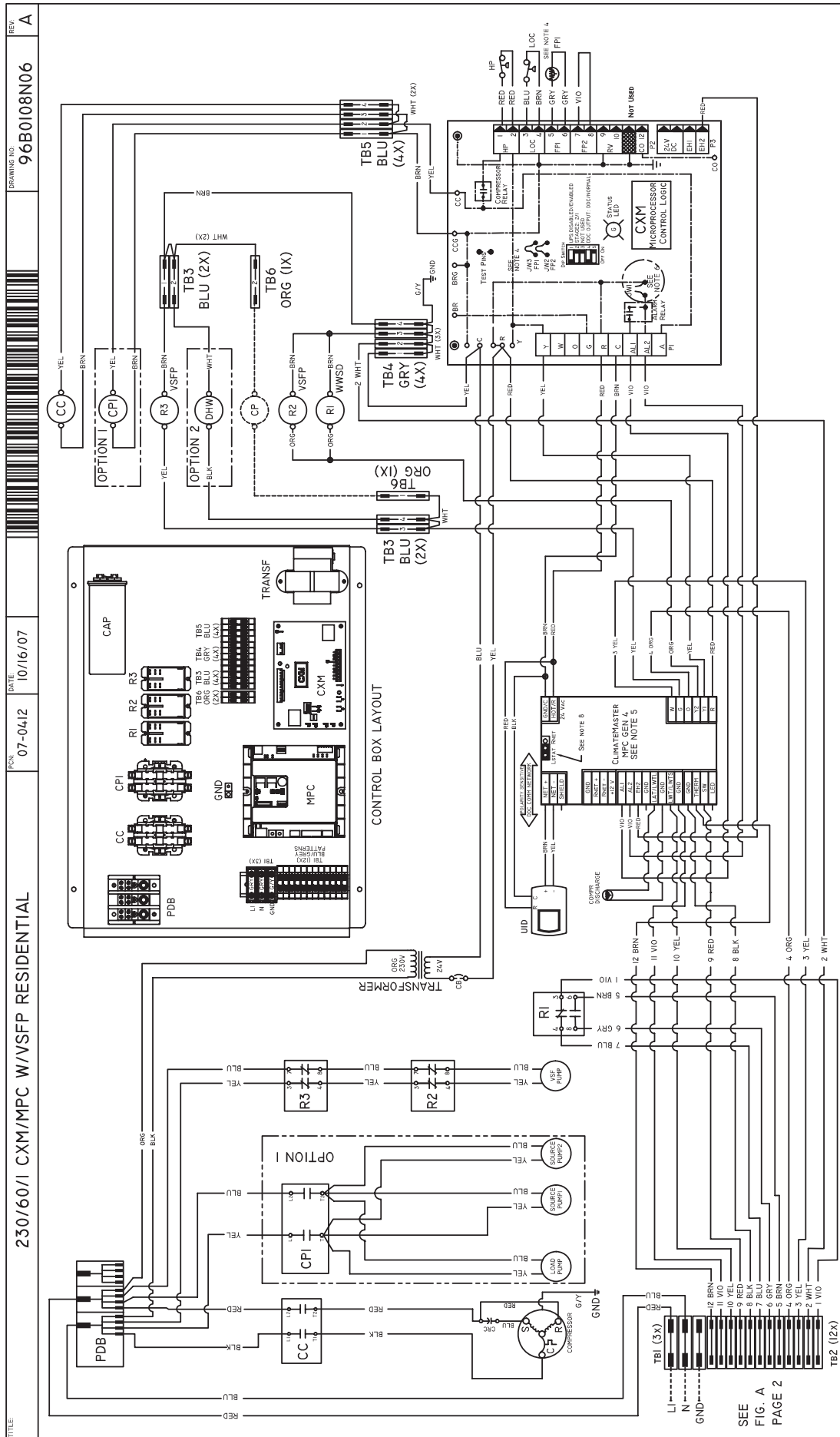

REV. A
 DRAWING NO. 96B0108N06
 DATE 10/16/07
 PCN 07-0412
 TITLE 230/60/1 CXM/MPC W/VSFP RESIDENTIAL

SEE FIG. A
 PAGE 2

TYPICAL WIRING DIAGRAM - 50YEW 230/60/1 UNITS WITH VSFP

TITLE: 230/60/1 CXM/MPC W/VSFP RESIDENTIAL	PCN: 07-0412	DATE: 10/16/07	DRAWING NO: 96B0108N06	REV: A
NOTES: 1. COMPRESSOR THERMALLY PROTECTED INTERNALLY. 2. ALL WIRING TO THE UNIT MUST COMPLY WITH CE AND LOCAL CODES. 3. 208/230V TRANSFORMER WILL BE CONNECTED FOR 230V OPERATION. FOR 208V OPERATION, THE TRANSFORMER MUST BE REWOUND OR A 208V TRANSFORMER MUST BE INSTALLED OPEN END OF ORG LEAD. AT "L1" AND ATTACH RED LEAD TO "L1". 4. FRI THERMISTOR PROVIDES LOW TEMPERATURE PROTECTION FOR WATER. 5. MANUAL FOR CONTROL WIRING TO THE UNIT. LOW VOLTAGE WIRING MUST BE CLASSIFIED AND VOLTAGE RATED EQUAL OR GREATER THAN UNIT SUPPLY VOLTAGE. 6. FACTORY CUT (W/C) OR JUMP (D/W) JUMPER. DRY CONTACT. 7. CONTROL BOX. (GROUND AVAILABLE FROM TOP TWO STAGEOFFS AS SHOWN.) 8. FIELD INSTALLED RELAY WITH N.C. CONTACTS. LOCATED IN WATER-TO-AIR UNIT. USE RELAY WITH TWO N.C. CONTACTS FOR TWO-STAGE UNITS (BREAK Y1 Y2).				
LEGEND: FACTORY LOW VOLTAGE WIRING FIELD LOW VOLTAGE WIRING FIELD LINE VOLTAGE WIRING PRINTED CIRCUIT TRACE THERMISTOR CONDENSATE PAN CIRCUIT BREAKER GROUND OPTIONAL COMMON POINT				
ALARM RELAY CONTACTS ALTA ALARM START BT/0A RELAY CONTACTS - N.C. C COMMON CRC COMPRESSOR RUN CAPACITOR CC COMPRESSOR CONTACTOR CP CONTACTOR PUMP DHV DHW TANK AQUASTAT DHW DOMESTIC HOT WATER TANK DS DISCONNECT SWITCH DTS DISCHARGE TEMP SWITCH EH ELECTRIC HEAT (OHV) FRI FRI THERMISTOR (WATER GROUP) GND GROUND HP HIGH PRESSURE SWITCH JPS JUMPER LOC LOCAL CHARGE PRESSURE SWITCH MPC MPC CONTROLLER MS MANUAL STARTER				
OA OUTSIDE AIR PDB POWER DISTRIBUTION BLOCK R RELAY RT 24VAC COOLING THERMISTAT*** RU 24VAC FROM WATER-TO-AIR UNIT*** SS SOFT STARTER (TORQUE LIMITER) TB TERMINAL BLOCK TRMS TRANSFORMER VSFP VARIABLE SPEED FLOOR PUMP WSP WARM WEATHER SHUT DOWN WZ 2ND STAGE HEATING**				
CMX CONTROLLER FAULT CODES DESCRIPTION OF OPERATION LED ALARM RELAY NORMAL MODE ON OPEN NORMAL MODE W/ UPS WARNING ON OPEN CMX IS NON-FUNCTIONAL OFF OPEN LOCKOUT FAST FLASH CLOSED OVER/UNDER VOLTAGE SHUTDOWN SLOW FLASH OPEN (CLOSED AFTER 15 MIN) TEST MODE-NO FAULT IN MEMORY FLASHING CODE 1 CYCLING CODE 1 TEST MODE-UP FAULT IN MEMORY FLASHING CODE 3 CYCLING CODE 3 TEST MODE-FRI FAULT IN MEMORY FLASHING CODE 4 CYCLING CODE 4 TEST MODE-CD FAULT IN MEMORY FLASHING CODE 5 CYCLING CODE 5 TEST MODE-CD ZVAC IN MEMORY FLASHING CODE 6 CYCLING CODE 6 TEST MODE-OVER/UNDER VOLTAGE FLASHING CODE 7 CYCLING CODE 7 TEST MODE-UPS IN MEMORY FLASHING CODE 8 CYCLING CODE 8 SWAPPED FPM/FPZ LOCKOUT FLASHING CODE 9 CYCLING CODE 9				

LOW VOLTAGE TERMINAL STRIP CONNECTION IDENTIFICATION

TERMINAL	LABEL	DESCRIPTION
12	OA	OUTDOOR AIR THERMISTOR CONNECTION
11	BT/OA	BUFFER TANK/OUTDOOR AIR TEMPERATURE THERMISTOR (SHARED) CONNECTION
10	BT	BUFFER TANK THERMISTOR CONNECTION
9	DH	WATER HEATER TANK THERMISTOR CONNECTION
8	DH	WATER HEATER TANK THERMISTOR CONNECTION
7	F	RADIANT FLOOR ZVAC INTERRUPT (TERMINALS 1 & 7) -- IWSD
6	RU	ZVAC SIGNAL TO COOLING UNIT
5	RT	ZVAC SIGNAL TO COOLING THERMOSTAT
4	W2	ZVAC SIGNAL TO ENABLE BACKUP BOILER OR 2ND STAGE HEATING
3	EH	ZVAC SIGNAL TO ENABLE OPTIONAL EMERGENCY ELECTRIC WATER HEATER
2	C	COMMON FOR EXTERNAL RELAY COILS
1	F	RADIANT FLOOR ZVAC INTERRUPT (TERMINALS 1 & 7) -- IWSD

INPUT#	INPUT NAME (SILK SCREEN)	INPUT FUNCTION (PROGRAM)	ANALOG SIGNAL	DIGITAL SIGNAL
1	AL1 & AL2	LOCKOUT ALARM	NO	YES
2	EHZ/GND	PULSE CODE SIGNAL	NO	YES
3	LAT/LWTL & GND	COMP DISCHARGE TEMP	YES	NO
4	LWTL/WTS & GND	BUFFER TANK TEMP SENSOR	YES	NO
5	GND & THERM	OAT	YES	NO
6	GND & SW	DHWS	YES	NO

OUTPUT#	OUTPUT NAME (SILK SCREEN)	OUTPUT NAME (PROGRAM)
1	X1	COMPRESSOR/SBL PUMPS
2	X2	WZSD
3	O	2ND STAGE HEATING
4	G	3-WAY VALVE (OHV)
5	W	EMERGENCY DHW

SEE APPLICATION MANUAL FOR FIELD WIRING

UNIT STARTING & OPERATING CONDITIONS

Operating Limits

Environment – This unit is designed for indoor installation only.

Power Supply – A voltage variation of +/- 10% of nameplate utilization voltage is acceptable.

Starting Conditions

50YEW Units – Units start and operate in an ambient of 45°F [7.2°C] with entering Load Water at 50°F [10°C], entering Source Water at 30°F [-1.1°C] and both Load and Source Water at the stated flow rates of 3 gpm per ton for initial winter start-up.

Notes:

1. These are not normal or continuous operating conditions. It is assumed that winter start-up is to bring the building space up to occupancy temperatures.
2. Voltage utilization range complies with ARI Standard 110.

Determination of operating limits is dependent primarily upon three factors: 1) entering load temperature. 2) entering source temperature and 3) ambient temperature. When any one of these factors is at minimum or maximum levels, the other two factors should be at normal levels to ensure proper unit operation.

Extreme variations in temperature and humidity and corrosive water will adversely affect unit performance, reliability, and service life.

Table 7: Operating Limits

Source Side Water Limits	Heating
Minimum Entering Water	20°F [-6.6°C]
Normal Entering Water	60°F [15.6°C]
Maximum Entering Water	90°F [32.2°C]
Load Side Water Limits	
Minimum Entering Water	60°F [15.6°C]
Normal Entering Water	100°F [37.8°C]
Maximum Entering Water	140°F [60.0°C]

UNIT & SYSTEM CHECKOUT

⚠ WARNING! ⚠

WARNING! Verify ALL water controls are open and allow water flow prior to engaging the compressor. Freezing of the coax or water lines can permanently damage the heat pump.

⚠ WARNING! ⚠

WARNING! To avoid equipment damage, DO NOT leave system filled in a building without heat during the winter unless anti-freeze is added to system water. Condenser coils never fully drain by themselves and will freeze unless winterized with antifreeze.

BEFORE POWERING SYSTEM, please check the following:

UNIT CHECKOUT

- ❑ **Balancing/Shutoff Valves:** Ensure all isolation valves are open, water control valves wired and open or coax may freeze and burst.
- ❑ **Line Voltage and Wiring:** Ensure Voltage is within an acceptable range for the unit and wiring and fuses/breakers are properly sized. Low voltage wiring is complete.
- ❑ **Unit Control Transformer:** Ensure transformer has properly selected control voltage tap. 208-230V units are factory wired for 230V operation unless specified otherwise.
- ❑ **Entering Water:** Ensure entering water temperatures are within operating limits of Table 7.
- ❑ **Low Water Temperature Cutout:** Verify low water temperature cut-out on CXM/DXM is properly set.
- ❑ **Water Flow Balancing:** Verify inlet and outlet water temperatures on both Load and source are recorded for each heat pump upon startup. This check can eliminate nuisance trip outs and high velocity water flows that can erode heat exchangers.
- ❑ **Unit Controls:** Verify CXM or DXM field selection options are proper and complete.

SYSTEM CHECKOUT

- ❑ **System Water Temperature:** Check load and source water temperature for proper range and also verify heating and cooling setpoints for proper operation.
- ❑ **System pH:** System water pH is 7.5 - 8.5. Proper pH promotes longevity of hoses and fittings.
- ❑ **System Flushing:** Water used in the system must be potable quality initially and clean of dirt, piping slag, and strong chemical cleaning agents. Verify all air is purged from the system. Air in the system can cause poor operation or system corrosion.
- ❑ **Cooling Tower/Boiler:** Check equipment for proper setpoints and operation.
- ❑ **Low Water Temperature Cutout:** Verify low water temperature cut-out controls are provided for the outdoor portion of the loop or operating problems will occur.
- ❑ **Miscellaneous:** Note any questionable aspects of the installation.

Figure 15: Test Mode Pins

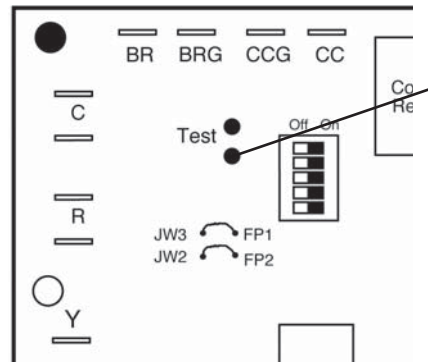

Short test pins together to enter Test Mode and speed-up timing and delays for 20 minutes.

CXM Board

UNIT START-UP PROCEDURE

⚠ WARNING! ⚠

WARNING! When the disconnect switch is closed, high voltage is present in some areas of the electrical panel. Exercise caution when working with energized equipment.

1. Adjust all valves to their full open position. Turn on the line power to all heat pump units.
2. Operate each heat pump in the heating cycle. Verify heat exchanger flow rates based upon table 7 and temperature drop/rise based upon unit performance tables.
3. Establish a permanent operating record by logging the unit operating conditions at initial start-up for each unit.
4. If a unit fails to operate, conduct the following checks:
 - a. Check the voltage and current. They should comply with the electrical specifications described on the unit nameplate.

- b. Look for wiring errors. Check for loose terminal screws where wire connections have been made on both the line and low-voltage terminal boards.
- c. Check the supply and return piping. They must be properly connected to the inlet and outlet connections on the unit.
- d. If the checks described above fail to reveal the problem and the unit still will not operate, contact a trained service technician to ensure proper diagnosis and repair of the equipment.

Note: Units have a five minute time delay in the control circuit that can be bypassed on the CXM PCB.

CXM/DXM Safety Control Reset

Lockout - In Lockout mode, the Status LED will begin fast flashing. The compressor relay is turned off immediately. Lockout mode can be soft reset via the "Y" input or can be hard reset via the disconnect. The last fault causing the lockout will be stored in memory and can be viewed by going into test mode.

Fault Retry - In Fault Retry mode, the Status LED begins slow flashing to signal that the control is trying to recover from a fault input. The CXM control will stage off the outputs and then "try again" to satisfy the thermostat "Y" input call. Once the input calls are satisfied, the control will continue on as if no fault occurred. If 3 consecutive faults occur without satisfying the "Y" input call, then the control will go to Lockout mode. The last fault causing the lockout will be stored in memory and can be viewed by going into test mode.

⚠ WARNING! ⚠

WARNING! Verify ALL water controls are open and allow water flow prior to engaging the compressor. Freezing of the coax or water lines can permanently damage the heat pump.

Table 8: Heat Exchanger Water Pressure Drop

Model	GPM [l/m]	Pressure Drop psi [kPa]		
		30°F [-1°C]	50°F [10°C]	70°F [21°C]
Source/Outdoor Coax				
010	6.6 [25.0]	0.60 [4.13]	0.48 [3.31]	0.37 [2.55]
	8.3 [31.5]	0.85 [5.68]	0.73 [4.90]	0.60 [4.03]

Model	GPM [l/m]	Pressure Drop psi [kPa]			
		70°F [21°C]	90°F [32°C]	110°F [43°C]	130°F [54°C]
Load/Indoor Coax					
010	5.4 [20.5]	0.61 [4.20]	0.50 [3.45]	0.39 [2.69]	0.32 [2.21]
	7.3 [27.7]	1.13 [7.79]	0.97 [6.68]	0.82 [5.65]	0.70 [4.82]

Multiply psi by 2.31 to obtain feet of head
 Multiply kPa by 10 to obtain mBar

Consult the CXM/DXM AOM for complete descriptions.

PREVENTIVE MAINTENANCE

Water Coil Maintenance –

(Direct Ground Water Applications Only)

If the installation is performed in an area with a known high mineral content (125 P.P.M. or greater) in the water, it is best to establish with the owner a periodic maintenance schedule so the coil can be checked regularly. Consult the well water applications section of this manual for a more detailed water coil material selection. Should periodic coil cleaning be necessary, use standard coil cleaning procedures which are compatible with either the heat exchanger material or copper water lines. Generally, the more water flowing through the unit the less chance for scaling.

Water Coil Maintenance –

(All Other Water Loop Applications)

Generally water coil maintenance is not needed however, if the installation is located in a system with a known high dirt or debris content, it is best to establish with the owner a periodic maintenance schedule so the coil can be checked regularly. These dirty installations are a result of the deterioration of iron or galvanized piping or components in the system or open cooling towers requiring heavy chemical treatment and mineral buildup through water use. Should periodic coil cleaning be necessary, use standard coil cleaning procedures which are compatible with both the heat exchanger material and copper water lines. Generally, the more water flowing through the unit, the less chance for scaling, however excessive flow rates can produce water (or debris) velocities that can erode the heat exchanger wall and ultimately produce leaks.

Compressor

Conduct annual amperage checks to ensure amp draw is no more than 10% greater than that indicated by serial plate data.

Cabinet

Do not allow water to stay in contact with the cabinet for long periods of time to prevent corrosion of the cabinet sheet metal. Generally equipment cabinets are set up from the floor a few inches for prevention. The cabinet can be cleaned using a mild detergent.

Refrigerant System

To maintain sealed circuit integrity, do not install service gauges unless unit operation appears abnormal. Reference the operating chart for pressure and temperatures. Verify that water flow rates are at proper levels before servicing the refrigerant circuit.

WARRANTY

CARRIER CORPORATION LIMITED EXPRESS WARRANTY/LIMITATION OF REMEDIES AND LIABILITY FOR RESIDENTIAL GEOTHERMAL PRODUCTS



It is expressly understood that unless a statement is specifically identified as a warranty, statements made by Carrier Corporation, a Delaware corporation, ("Carrier") or its representatives, relating to Carrier's products, whether oral, written or contained in any sales literature, catalog or agreement, are not express warranties and do not form a part of the basis of the bargain, but are merely Carrier's opinion or commendation of Carrier's products.
EXCEPT AS SPECIFICALLY SET FORTH HEREIN, THERE IS NO EXPRESS WARRANTY AS TO ANY OF CARRIER'S PRODUCTS. CARRIER MAKES NO WARRANTY AGAINST LATENT DEFECTS. CARRIER MAKES NO WARRANTY OF MERCHANTABILITY OF THE GOODS OR OF THE FITNESS OF THE GOODS FOR ANY PARTICULAR PURPOSE.

GRANT OF LIMITED EXPRESS WARRANTY

Carrier warrants its residential geothermal products, purchased and retained in the United States of America and Canada, to be free from defects in material and workmanship under normal use and maintenance as follows: (1) 50YD, 50YE, 50YC and 38WQS heat pump units built or sold by Carrier ("Carrier Geothermal Units") for five (5) years from the Warranty Inception Date (as defined below); (2) Auxiliary electric heaters and geothermal pumping modules built or sold by Carrier, when installed with Carrier Geothermal Units, for five (5) years from the Warranty Inception Date (as defined below); (3) Sealed refrigerant circuit components of Carrier Geothermal Units (which components only include the compressor, refrigerant to air/water heat exchangers, reversing valve body and refrigerant metering device) for ten (10) years from the Warranty Inception Date (as defined below). The "Warranty Inception Date" shall be the date of original unit installation, or six (6) months from date of unit shipment from Carrier, whichever comes first.

To make a claim under this warranty, parts must be returned to Carrier in Oklahoma City, Oklahoma, freight prepaid, no later than ninety (90) days after the date of the failure of the part; if Carrier determines the part to be defective and within Carrier's Limited Express Warranty, Carrier shall, when such part has been either replaced or repaired, return such to a factory recognized distributor, dealer or service organization, F.O.B. Carrier, Oklahoma City, Oklahoma, freight prepaid. The warranty on any part repaired or replaced under warranty expires at the end of the original warranty period.

This warranty does not cover and does not apply to: (1) Air filters, fuses, refrigerant, fluids, oil; (2) Products relocated after initial installation; (3) Any portion or component of any system that is not supplied by Carrier, regardless of the cause of the failure of such portion or component; (4) Products on which the unit identification tags or labels have been removed or defaced; (5) Products on which payment to Carrier, or to the owner's seller, is in default; (6) Products subjected to improper or inadequate installation, maintenance, repair, wiring or voltage conditions; (7) Products subjected to accident, misuse, negligence, abuse, fire, flood, lightning, unauthorized alteration, misapplication, contamination or corrosive air or liquid supply, operation at abnormal air or liquid temperatures or flow rates, or opening of the refrigerant circuit by unqualified personnel; (8) Mold, fungus or bacteria damages; (9) Corrosion or abrasion of the product; (10) Products supplied by others; (11) Products which have been operated in a manner contrary to Carrier's printed instructions; (12) Products which have insufficient performance as a result of improper system design or improper application, installation, or use of Carrier's products; or (13) Electricity or fuel costs, or any increases or unrealized savings in same, for any reason whatsoever.

Carrier is not responsible for: (1) The costs of any fluids, refrigerant or system components supplied by others, or associated labor to repair or replace the same, which is incurred as a result of a defective part covered by Carrier's Limited Express Warranty; (2) The costs of labor, refrigerant, materials or service incurred in diagnosis and removal of the defective part, or in obtaining and replacing the new or repaired part; (3) Transportation costs of the defective part from the installation site to Carrier, or of the return of that part if not covered by Carrier's Limited Express Warranty; or (4) The costs of normal maintenance.

This Limited Express Warranty applies to Carrier Residential Geothermal products manufactured on or after June 9, 2003 (Carrier Geothermal Units with serial numbers beginning with 2403 or later), and is not retroactive to any products produced prior to June 9, 2003 (Carrier Geothermal Units with serial numbers beginning with 2303 and earlier).

Limitation: This Limited Express Warranty is given in lieu of all other warranties. If, notwithstanding the disclaimers contained herein, it is determined that other warranties exist, any such express warranty, including without limitation any express warranties or any implied warranties of fitness for particular purpose and merchantability, shall be limited to the duration of the Limited Express Warranty.

LIMITATION OF REMEDIES

In the event of a breach of the Limited Express Warranty, Carrier will only be obligated at Carrier's option to repair the failed part or unit, or to furnish a new or rebuilt part or unit in exchange for the part or unit which has failed. If after written notice to Carrier's factory in Oklahoma City, Oklahoma of each defect, malfunction or other failure, and a reasonable number of attempts by Carrier to correct the defect, malfunction or other failure, and the remedy fails of its essential purpose, Carrier shall refund the purchase price paid to Carrier in exchange for the return of the sold goods(s). Said refund shall be the maximum liability of Carrier. **THIS REMEDY IS THE SOLE AND EXCLUSIVE REMEDY OF THE BUYER OR PURCHASER AGAINST CARRIER FOR BREACH OF CONTRACT, FOR THE BREACH OF ANY WARRANTY OR FOR CARRIER'S NEGLIGENCE OR IN STRICT LIABILITY.**

LIMITATION OF LIABILITY

Carrier shall have no liability for any damages if Carrier's performance is delayed for any reason or is prevented by any event such as, but not limited to: any war, civil unrest, government restrictions or restraints, strikes, or work stoppages, fire, flood, accident, shortages of transportation, fuel, material, or labor, acts of God or any other reason beyond the sole control of Carrier. **CARRIER EXPRESSLY DISCLAIMS AND EXCLUDES ANY LIABILITY FOR CONSEQUENTIAL OR INCIDENTAL DAMAGE IN CONTRACT, FOR BREACH OF ANY EXPRESS OR IMPLIED WARRANTY, OR IN TORT, WHETHER FOR CARRIER'S NEGLIGENCE OR AS STRICT LIABILITY.**

OBTAINING WARRANTY PERFORMANCE

Normally, the dealer or service organization who installed the products will provide warranty performance for the owner. Should the installer be unavailable, contact any Carrier recognized distributor, dealer or service organization. If assistance is required in obtaining warranty performance, write or call:

Carrier Corporation • Customer Service • 7300 SW 44th Street • Oklahoma City, Oklahoma 73179 • (405) 745-2920

NOTE: Some states or Canadian provinces do not allow limitations on how long an implied warranty lasts, or the limitation or exclusions of consequential or incidental damages, so the foregoing exclusions and limitations may not apply to you. This warranty gives you specific legal rights, and you may also have other rights which vary from state to state and from Canadian province to Canadian province.

Please refer to the Carrier Installation, Operation and Maintenance Manual for operating and maintenance instructions.

Rev: 04/06
Part No.: CA185

NOTES

IOM Revision Log:

Date	Page #	Description
31 Jan, 2008	17	Added Buffer Tank Interface Input Table
29 Nov, 2007	All	First Published



97B0064N01

7300 S.W. 44th Street
 Oklahoma City, OK 73179
 Phone: 405-745-2920
 Fax: 405-745-6620

The manufacturer works continually to improve its products. As a result, the design and specifications of each product at the time for order may be changed without notice and may not be as described herein. Please contact the Manufacturer's Customer Service Department at 1-405-745-2920 for specific information on the current design and specifications. Statements and other information contained herein are not express warranties and do not form the basis of any bargain between the parties, but are merely the manufacturer's opinion or commendation of its products.

The management system governing the manufacture of these products is ISO 9001:2000 certified.