

Installation Instructions

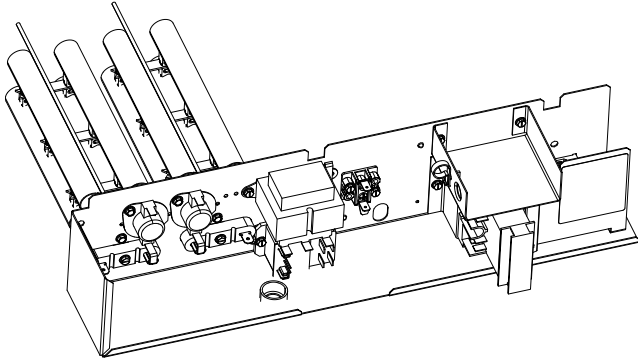

A09221

Fig. 1 - 5, 7-1/2 and 11-kW Electric Heater Package (KFEFH)

NOTE: Read the entire instruction manual before starting the installation.

SAFETY CONSIDERATIONS

Improper installation, adjustment, alteration, service, maintenance, or use can cause explosion, fire, electrical shock or other conditions which may cause death, personal injury or property damage. Consult a qualified installer, service agency, or your distributor or branch for information or assistance. The qualified installer or agency must use factory-authorized kits or accessories when modifying this product. Refer to the individual instructions packaged with the kits or accessories when installing.

Follow all safety codes. Wear safety glasses, protective clothing and work gloves. Use quenching cloths for brazing operations. Have fire extinguisher available. Read these instructions thoroughly and follow all warnings or cautions attached to the unit. Consult local building codes and the current editions of the National Electrical Codes (NEC) NFPA 70.

In Canada, refer to the current editions of the Canadian Electrical Code CSA C22.1.

Recognize safety information. This is the safety-alert symbol . When you see this symbol on the unit and in instructions or manuals, be alert to the potential for personal injury.

Understand the signal words **DANGER**, **WARNING** and **CAUTION**. These words are used with the safety-alert symbol. **DANGER** identifies the most serious hazards which **will** result in severe personal injury or death. **WARNING** signifies hazards which **could** result in personal injury or death. **CAUTION** is used to identify unsafe practices, which **may** result in minor personal injury or product and property damage. **NOTE** is used to highlight suggestions which **will** result in enhanced installation, reliability, or operation.

WARNING

ELECTRICAL SHOCK HAZARD

Failure to follow this warning could result in personal injury or death.

Before installing, modifying or servicing system, always turn off main power to system. There may be more than one disconnect switch. Lock out and tag switch with a suitable warning label.

CAUTION

CUT HAZARD

Failure to follow this caution may result in personal injury.

Sheet metal parts may have sharp edges or burrs. Use care and wear appropriate protective clothing and gloves when handling parts.

INTRODUCTION

These instructions cover the installation of field-installed electric heater packages in model FF1ENP019, 025, 031 & 037 fan coil units. The X-13 motor contains a 90 second blower-off delay for increased Seasonal Energy Efficiency Rating (SEER).

Use these instructions in conjunction with the installation instructions packaged with the unit being installed.

DESCRIPTION AND USAGE

Electric heater packages are available in capacities ranging from 5-through 11-kW. The factory-shipped heater package (Fig. 1.) contains a completely assembled and wired heater with controls and mounting screws.

NOTE: Before proceeding with the installation of heater packages, check the electrical power supply to see that it corresponds with the rating plate on the unit. Also ensure service provided by the utility is sufficient to handle the additional load generated by the heaters.

All field wiring must be in accordance with the NEC and any local codes or ordinances that may apply.

See Table 1 for heater package part numbers, wire size, overcurrent protection sizes, and fan-coil or packaged unit sizes. All field-installed heater packages are factory wired for 230-v transformer operation. When 208-v transformer operation is desired, move the black primary lead from the 230-v terminal to the 208-v terminal.

Table 1 – Electric Heater and Cooling Control Data

PART NO.	UNIT SIZE	VOLTAGE	NOM kW @ 240-V	HEATER AMPS	HEATER CAPACITY (BTUH)	WIRE RATING (°C)	MIN WIRE SIZE*	MIN AMPACITY	MAX CIRCUIT PROTECTION
KFEEH0101D05	019 025 031 037	208/230	5.0	18.1/19.8	12799/15700	75	10/10	27.8/29.9	30/30
KFEEH0201D75	019 025 031 037	208/230	7.5	27.1/30.0	19215/23515	75	8/8	39.0/42.6	40/50
KFEEH0301D11	025 031 037	208/230	11.0	39.8/43.8	25597/31331	75	6/6	54.9/59.9	60/60

* Use copper wire only. If other than wire specified is used, size can be determined from unit total amps given in above table and applicable table of National Electrical Code (NEC). Wire size must not create a voltage drop between service panel and unit in excess of 2 percent of unit rated voltage.

INSTALLATION

⚠ WARNING

ELECTRICAL SHOCK HAZARD

Failure to follow this warning could result in personal injury or death.

Before installing, modifying or servicing system, always turn off main power to system. There may be more than one disconnect switch. Lock out and tag switch with a suitable warning label. Turn off the accessory heater power switch (if applicable).

⚠ WARNING

ELECTRICAL SHOCK HAZARD

Failure to follow this warning could result in personal injury or death.

The unit cabinet must have an uninterrupted, unbroken electrical ground. This ground may consist of an electrical wire connected to the unit ground screw in the control compartment, or conduit approved for electrical ground when installed in accordance with NEC, NFPA 70 National Fire Protection Association (latest edition) (in Canada, Canadian Electrical Code CSA C22.1) and local electrical codes.

NOTE: Use UL-listed conduit and conduit connector for connecting supply wire(s) to unit to obtain proper grounding. If conduit connection uses reducing washers, a separate ground wire must be used. Grounding may also be accomplished by using grounding lugs provided in control box.

INSTALL HEATER PACKAGE

1. Remove blower access panel. See Fig. 2.
2. Insert heater into opening, engaging element support bars into holes in back of blower housing, and attach with provided screws. See Fig. 2.
3. Connect the motor Molex plug, gray wire and violet wire coming out of the bottom of the heater package to the X-13 (Genteq) motor. See wiring label for proper speed tap selection.

4. Route thermostat leads through small knockout in top of unit. Use plastic grommet provided with heater package to protect leads where they pass through casing.
5. Make low-voltage splice connections in low-voltage control box. (See FF1 E Installation Instructions.)
6. Route unit power supply through knockout in top of unit and connect to line side of disconnect. Connect ground wire to ground lug. See wiring label to make connections.
7. Remove disconnect pullout.
8. Replace access panel.
9. Insert disconnect pullout through hole in access panel.

NOTE: To comply with UL and cUL requirements, place a check in the appropriate box on the fan coil or packaged unit rating plate to indicate the heater model number installed.

NOTE: Top panel not shown for clarity

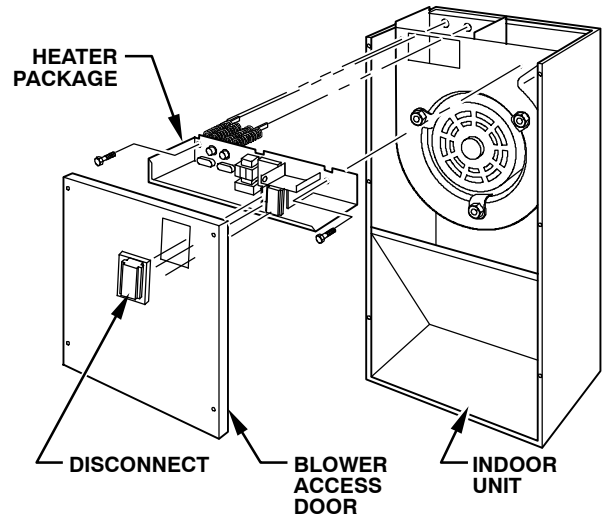

Fig. 2 - Installing Heater Package

A98334

START-UP

Refer to instructions shipped with the indoor unit and related outdoor unit.

Turn on unit and heater power. Set thermostat to “call for heat”. Check operation of heaters. Adjust fan speed as described in unit Installation Instructions as required.