

Installation Instructions

Outdoor Air Temperature Sensor

TSTATXXSEN01-B

NOTE: Read the entire instruction manual before starting the installation.

This symbol → indicates a change since the last issue.

SAFETY CONSIDERATIONS

Read and follow manufacturer instructions carefully. Follow all local electrical codes during installation. All wiring must conform to local and national electrical codes. Improper wiring or installation may damage thermostat sensor. It is important to recognize safety information. This is the safety-alert symbol . When you see this symbol on the equipment and in instructions or manuals, be alert to the potential for personal injury. Understand the signal words DANGER, WARNING, and CAUTION. These words are used with the safety-alert symbol. DANGER identifies the most serious hazards which will result in severe personal injury or death. WARNING signifies hazards which could result in personal injury or death. CAUTION is used to identify unsafe practices which would result in minor personal injury or product and property damage. **NOTE** is used to highlight suggestions which will result in enhanced installation, reliability, or operation.

INTRODUCTION

The Outdoor Air Temperature Sensor is 10K based thermistor, which can be used as an accessory for select model thermostats and zoning systems. This sensor provides outdoor air temperature information for the control system, as well as an indication of outdoor temperature for the homeowner.

The TSTATXXSEN01-B sensor is completely interchangeable with the older style Part No. TSTATXXSEN01. This sensor is improved for easier installation and wiring hook-up.

→ The new Infinity/Evolution systems may require an OAT sensor when a non-communicating outdoor unit is installed. See Procedure 4 — Special Applications Information for more detail.

INSTALLATION

There are 3 approved mounting locations for this sensor. Each location has certain advantages as well as disadvantages. Read each procedure discussed below carefully, then determine the best location for each given application.

PROCEDURE 1—MOUNTING SENSOR TO THE OUTSIDE WALL

The traditional mounting location has been on an outside wall. The only recommended wall for mounting is the north side of the building. The effects of the sun warming the other 3 walls (i.e. east, south, and west) can produce unacceptable temperature errors under the right conditions. If the north wall is used (as recommended), the mounting height can be from near ground level, all the way up into the eave. It is always best to mount the sensor at least 2- to 3-ft above grade level. The sensor should be mounted inside an ordinary or weatherproof outlet box. (See Fig. 1.)

Advantages: This is the most accurate way of reading outdoor temperature.

Disadvantages: This application requires dedicated wire between the sensor location and the indoor termination point.

IF THIS PROCEDURE IS SELECTED:

Select the exact mounting location and route a 2-conductor interconnecting wire (through the building) between the indoor termination point and the outdoor sensor. For zoning systems, this will be terminals OAT and OATC at the Equipment Controller. For corporate thermostats and/or the Thermidistat Control™, the termination point will be terminals S1 and S2 at that device. It is acceptable to splice wires to complete this connection. However, allow sufficient extra wire for excess on each end to complete the connection. Solid thermostat or stranded, 22 AWG (or heavier wire) may be used. Use the supplied wire nuts to attach the sensor to the interconnecting wire. The wire nut connection should be located within the outlet box or within the inside wall (check your local codes). (See Fig. 1, 2, and 3.)

1. Drill a suitable hole in the building wall at the selected location.
2. Remove rear knockout from electric box, route wire through box, and attach to wall. Inset sensor in outlet box and make connections with supplied wire nuts. .

NOTE: Sensor polarity is not important, avoid sensor from touching inside edge of outlet box

3. Seal wire entrance through the wall.
4. Attach cover to box.

NOTE: Any moisture entering box will not harm sensor.

5. Connect other end as shown in Fig. 2 or 3.

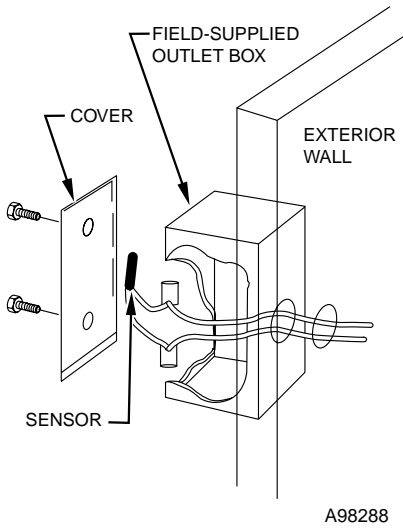

Fig. 1—Mounting Sensor to Outside Wall

A98288



Fig. 2—Thermostat or Thermidistat Control—Direct Connection

A98213

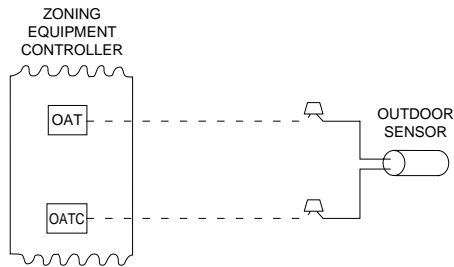

Fig. 3—Zoning System—Direct Connection

A98215

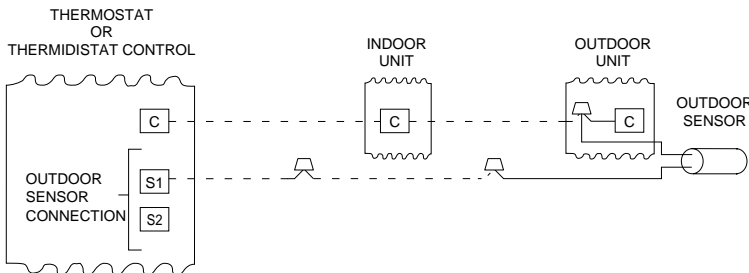

Fig. 4 — Thermostat or Thermidistat Control - Outdoor Unit Connection

A98214

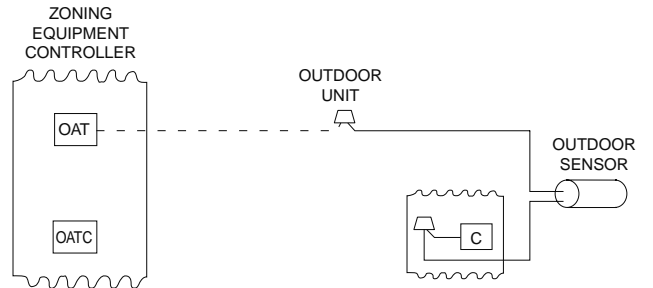

Fig. 5 — Zoning System - Outdoor Unit Connection

A01396

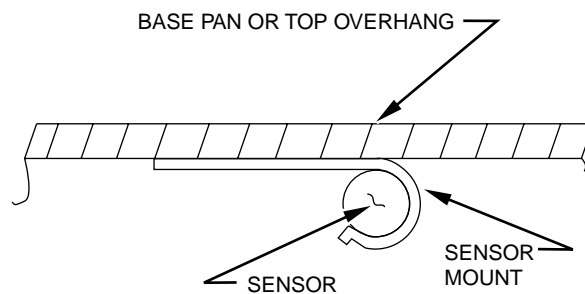

Fig. 6 — Sensor Mounting

A98289

PROCEDURE 2—MOUNTING SENSOR UNDER THE OUTDOOR UNIT

Locating the sensor under the outdoor unit may simplify both wiring and mounting. There is the likelihood that an unused thermostat wire may exist between the indoor and outdoor unit. Use this wire to carry the temperature sensor signal from the outdoor to the indoor unit. However, another single wire must still be used between the indoor unit and the indoor termination point. (See Fig. 4 and 5.)

NOTE: The "C" connection between the indoor unit control, and the outdoor unit provides the ground path for the sensor signal. No wire is needed on S2 connection back to the thermostat, Thermidistat Control, or OATC (zoning system).

Advantages: Convenient mounting and wiring of outdoor air temperature sensor.

Disadvantages: a) The sun may have some effect when unit is not running. b) Defrost cycle (if heat pump) can introduce a small temperature error while defrosting. c) Snow and ice buildup under the outdoor unit may introduce error. d) Landscaping around outdoor unit may affect temperature reading.

IF THIS PROCEDURE IS SELECTED

The sensor should be mounted under the northeast corner of the outdoor unit. Use the supplied sensor mounting clip. (See Fig. 6.) This has an adhesive pad to mount the sensor under the unit in a desirable location. Make sure the mounting surface is clean and dry. When applying, remove protective paper to expose pad surface and hold in place for 5 to 10 seconds ensuring good contact. However before doing all this, first check and make sure at least 1 unused wire is available in the control cable between the indoor and outdoor units. If one is available, no additional wire will be needed between indoor and outdoor units.

1. Remove door from outdoor unit and locate drain pan slot nearest the northwest corner of the unit. Depending on the amount of clearance under the unit, it may be easier to insert the sensor wires through the slot from the outside, or to slip the sensor itself through the slot from the inside. Select the easier of the two and route the sensor wires through the drain slot. After the sensor is located, snap it into the mounting clip. Wipe clean from under the base pan any loose dirt that may be on the mounting surface. Peel backing protective paper and firmly press sensor, holding it in place for a few seconds, to the underside of the base pan near the drain slot.
2. Route the sensor wires inside the unit to near the 24-vac connection terminals. Connect 1 sensor wire to the spare wire in the control cable using a supplied wire nut. Connect the other sensor wire to the "C" junction. (See Fig. 4 and 5.) At the indoor unit, a single wire must connect from the spare wire to terminal OAT (zoning system) or terminal S1 (thermostats and/or Thermidistat Control).

PROCEDURE 3—MOUNTING SENSOR UNDER THE TOP OVERHANG OF OUTDOOR UNIT

Locating the sensor under the top overhang of the outdoor unit could simplify both wiring and mounting. The sensor may also be mounted under the top overhang above the service ports. The wiring for this method will be the same as for mounting the sensor under the unit. (See Fig. 4 or 5.)

Advantages: a) Convenient mounting and wiring of outdoor air sensor. b) Avoids effects of ice and snow. c) Easiest to mount and wire.

Disadvantages: There may be significant heating effect from the sun while unit is off.

IF THIS PROCEDURE IS SELECTED:

1. Determine sensor location under overhang and wiring route to connection point. Snap sensor into mounting clip. (See Fig. 6.) Wipe from under the top any loose dirt that may be on the mounting surface. Peel backing from mounting clip and press to underside of top overhang, holding firmly for a few seconds.
2. Route sensor wires into control box wiring area and connect as instructed for Procedure 2 above. The wiring for this method will be the same as for mounting the sensor under the unit. (See Fig. 4 and 5.)

TESTING COMPLETED WIRING

When properly connected, the sensor will display outdoor temperature when the UP and DOWN buttons on the thermostat/Thermidistat Control/User Interface are pressed together. If the connection is wrong or the sensor is not reading, the display will indicate "--" (2 dashes) instead of outdoor temperature. Use this to test a new installation.

To further troubleshoot, use a digital volt meter and measure voltage across the sensor. This should be between 2- and 3-vdc at mid-range outdoor temperatures (i.e. 60-75 degrees F). This same measurement should also be read at S1 and S2 (thermostat and/or Thermidistat Control) or OAT and OATC (zoning system).

The terminal voltages will be about 5-vdc with the sensor disconnected. The sensor itself can be checked by measuring its resistance (with sensor disconnected). Values are given in Table 1.

→ SPECIAL APPLICATION INFORMATION

PROCEDURE 4—OUTDOOR AIR TEMPERATURE SENSOR APPLIED WITH NEW COMMUNICATING CONTROL SYSTEM

NOTE: When using a conventional (or non-communicating) outdoor unit with the new Infinity / Evolution Systems, an Outdoor Temperature Sensor may be required. See Infinity / Evolution Installation Instructions to determine need.

If required, connect OAT sensor directly to HK42FZ022 furnace board / HK38EA002 fan coil board at OAT terminal block location. See Fig. 7 and Fig. 8.

NOTE: DO NOT connect OAT sensor at User Interface terminal block S1 & S2. This is reserved for remote room sensor only.

Table 1—Temperature/Ohm Relationship (Degrees F/ Ω)

TEMP F°	OHMS	TEMP F°	OHMS	TEMP F°	OHMS	TEMP F°	OHMS
0	85,378	33	31,738	66	13,138	99	5,961
1	82,710	34	30,855	67	12,811	100	5,827
2	80,135	35	30,000	68	12,493	101	5,697
3	77,649	36	29,171	69	12,184	102	5,570
4	75,249	37	28,367	70	11,883	103	5,446
5	72,931	38	27,589	71	11,591	104	5,326
6	70,693	39	26,834	72	11,307	105	5,208
7	68,531	40	26,103	73	11,031	106	5,094
8	66,442	41	25,394	74	10,762	107	4,982
9	64,475	42	24,706	75	10,501	108	4,873
10	62,475	43	24,039	76	10,247	109	4,767
11	60,592	44	23,393	77	10,000	110	4,663
12	58,771	45	22,766	78	9,760	111	4,562
13	57,012	46	22,158	79	9,526	112	4,464
14	55,311	47	21,568	80	9,298	113	4,368
15	53,667	48	20,996	81	9,077	114	4,274
16	52,077	49	20,441	82	8,862	115	4,183
17	50,540	50	19,902	83	8,651	116	4,094
18	49,054	51	19,379	84	8,448	117	4,007
19	47,616	52	18,872	85	8,250	118	3,922
20	46,225	53	18,379	86	8,056	119	3,839
21	44,880	54	17,902	87	7,868	120	3,758
22	43,578	55	17,438	88	7,685	121	3,679
23	42,318	56	16,987	89	7,507	122	3,602
24	41,099	57	16,550	90	7,333	123	3,527
25	39,920	58	16,125	91	7,164	124	3,453
26	38,778	59	15,713	92	7,000	125	3,382
27	37,672	60	15,312	93	6,839	126	3,312
28	36,602	61	14,923	94	6,683	127	3,243
29	35,566	62	14,545	95	6,531	128	3,177
30	34,563	63	14,178	96	6,383	129	3,112
31	33,591	64	13,822	97	6,238	130	3,048
32	32,650	65	13,475	98	6,098		

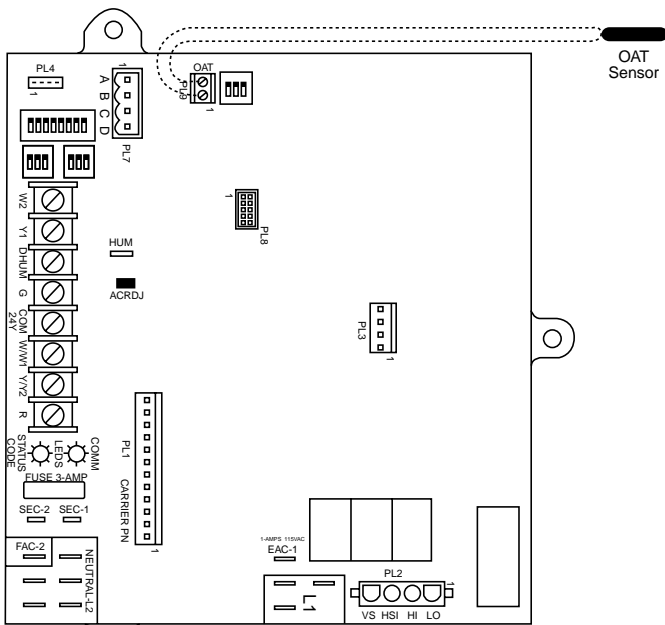

→ **Fig. 7 — HK42FZ022 Furnace Board w/OAT Connected**

A03230

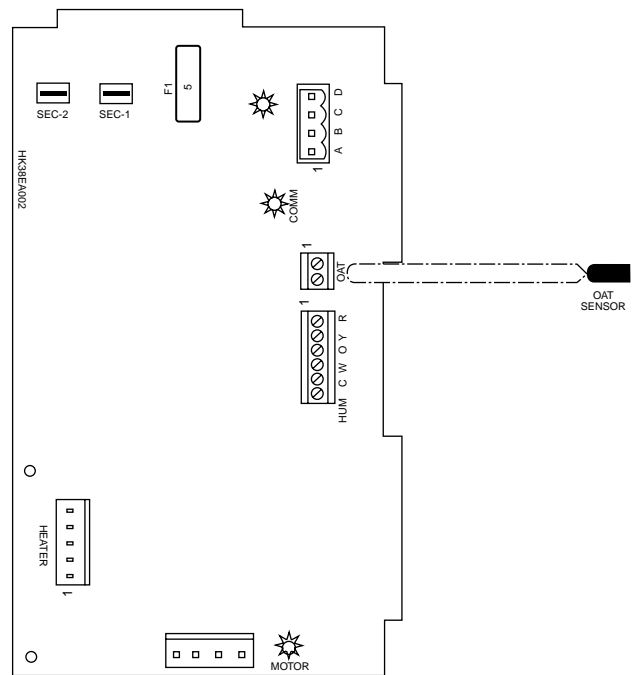

→ **Fig. 8 — HK38EA002 Fan Coil Board w/OAT Connected**

A04044