

**TOSHIBA**

*Carrier*

AIR CONDITIONER (MULTI TYPE)

## Installation Manual



EB99808701-1

### Indoor Unit

Model name: \_\_\_\_\_

Floor Console Exposed Type

**MML-AP0074H2UL**

**MML-AP0094H2UL**

**MML-AP0124H2UL**

**MML-AP0154H2UL**

**MML-AP0184H2UL**

**MML-AP0244H2UL**

For commercial use  
Pour usage commercial

Installation Manual 1 English

Manuel d'installation 17 Français

Please read this Installation Manual carefully before installing the Air Conditioner.

- This Manual describes the installation method of the indoor unit.
- For installation of the outdoor unit, follow the Installation Manual attached to the outdoor unit.

**ADOPTION OF NEW REFRIGERANT**

This Air Conditioner uses R410A an environmentally friendly refrigerant.

**Contents**

1 Precautions for safety ..... 1

2 Accessory parts ..... 2

3 Selection of installation place ..... 3

4 Installation ..... 4

5 Drain piping ..... 5

6 Refrigerant piping ..... 6

7 Electrical connection ..... 7

8 Applicable controls ..... 10

9 How to change the discharge port ..... 11

10 Test run ..... 12

11 Maintenance ..... 13

12 Troubleshooting ..... 13

**1 Precautions for safety**

Installing, starting up, and servicing air-conditioning equipment can be hazardous due to system pressures, electrical components, and equipment location (roofs, elevated structures, etc.).

Only trained, qualified installers and service mechanics should install, start-up, and service this equipment. Untrained personnel can perform basic maintenance functions such as cleaning heat exchanger. All other operations should be performed by trained service personnel.

Before working on the equipment, observe precautions in the literature and on tags, stickers, and labels attached to the equipment.

Follow all safety codes. Wear safety glasses and work gloves. Keep quenching cloth and fire extinguisher nearby during brazing. Use care in handling, rigging, and setting bulky equipment.

Read these instructions thoroughly and follow all warnings or cautions included in literature and attached to the unit. Consult local building codes and National Electrical Code (NEC) for special requirements. Recognize safety information. This is the safety-alert symbol . When you see this symbol on the unit and in instructions or manuals, be alert to the potential for personal injury. Understand these signal words: DANGER, WARNING, and CAUTION. These words are used with the safety-alert symbol.

DANGER identifies the most serious hazards which will result in severe personal injury or death. WARNING signifies hazards which could result in personal injury or death. CAUTION is used to identify unsafe practices which may result in minor personal injury or product and property damage. NOTE is used to highlight suggestions which will result in enhanced installation, reliability, or operation.

The manufacturer shall not assume any liability for the damage caused by not observing the description of this manual.

 **WARNING**



- **Only a qualified installer or service person is allowed to do installation work.**  
Inappropriate installation may result in water leakage, electric shock or fire.
- **Do not use any refrigerant different from the one specified for complement or replacement.**  
**Otherwise, abnormally high pressure may be generated in the refrigeration cycle, which may result in a failure or explosion of the product or an injury to your body.**
- **Connect ground wire. (grounding work)**  
Incomplete grounding may cause an electric shock.  
Do not connect ground wires to gas pipes, water pipes, lightning rods or ground wires for telephone wires.
- **Turn off all the circuit breaker before attempting any electrical work.**  
Failure to do so may cause electric shock.
- **Install the refrigerant pipe securely during the installation work before operating the air conditioner.**  
If the air conditioner is operated with the valve open and without the refrigerant pipe, the compressor sucks air and the refrigeration cycle is over pressurized, which may cause a burst or injury.
- **When moving the air conditioner for the installation into another place, do not enter any gaseous matter other than the specified refrigerant into the refrigeration cycle.**  
If air or any other gas is mixed in the refrigerant, the gas pressure in the refrigeration cycle becomes abnormally high and it resultingly causes pipe burst and injuries on persons.
- **Perform installation work properly according to the Installation Manual.**  
Inappropriate installation may result in water leakage, electric shock or fire.
- **When the air conditioner is installed in a small room, provide appropriate measures to ensure that the concentration of refrigerant leakage occur in the room does not exceed the critical level.**
- **Install the air conditioner securely in a location where the base can sustain the weight adequately.**
- **Perform the specified installation work to guard against an earthquake.**  
If the air conditioner is not installed appropriately, accidents may occur due to the falling unit.
- **If refrigerant gas has leaked during the installation work, ventilate the room immediately.**  
If the leaked refrigerant gas comes in contact with fire, noxious gas may generate.
- **After the installation work, confirm that refrigerant gas does not leak.**  
If refrigerant gas leaks into the room and flows near a fire source, such as a cooking range, noxious gas might generate.
- **Electrical work must be performed by a qualified electrician in accordance with the Installation Manual. Use an exclusive power supply for the air conditioner at the rated voltage.**  
An insufficient power supply capacity or inappropriate installation may cause fire.
- **Use the specified wires for wiring connect the terminals. Securely fix them to prevent external forces applied to the terminals from affecting the terminals.**
- **Conform to the regulations of the local electric company when wiring the power supply.**

- For the refrigerant recovery work (collection of refrigerant from the pipe to the compressor), stop the compressor before disconnecting the refrigerant pipe.  
If the refrigerant pipe is disconnected while the compressor is working with the valve open, the compressor sucks air and the refrigeration cycle is over pressurized, which may cause a burst or injury.
- Before carrying out the installation, maintenance, repair or removal work, set the circuit breaker to the OFF position.  
Otherwise, electric shocks may result.
- Do not touch the aluminum fin of the unit. You may injure yourself if you do so. If the fin must be touched for some reason, first put on protective gloves and safety work clothing, and then proceed.
- Install the air conditioner securely in a location where the base can sustain the weight adequately. If the strength is not enough, the unit may fall down resulting in injury.
- Install a circuit breaker that meets the specifications in the installation manual and the stipulations in the local regulations and laws.
- Install the circuit breaker where it can be easily accessed by the agent.
- Under no circumstances the power wire must not be extended. Connection trouble in the places where the wire is extended may give rise to smoking and/or a fire.
- Upon completion of the installation work, tell the user where the circuit breaker is located. If the user does not know where the circuit breaker is, he or she will not be able to turn it off in the event that trouble has occurred in the air conditioner.

### CAUTION

- This air conditioner adopts the new HFC refrigerant (R410A) which does not destroy ozone layer.
- The characteristics of R410A refrigerant are; easy to absorb water, oxidizing membrane or oil, and its pressure is approx. 1.6 times higher than that of refrigerant R22. Accompanied with the new refrigerant, refrigerating oil has also been changed. Therefore, during installation work, be sure that water, dust, former refrigerant, or refrigerating oil does not enter the refrigerating cycle.
- To prevent charging an incorrect refrigerant and refrigerating oil, the sizes of connecting sections of charging port of the main unit and installation tools are changed from those for the conventional refrigerant.
- Exclusive new tools are required for the new refrigerant (R410A).
- For connecting pipes, use new and clean piping designed for R410A, and make sure that water or dust does not enter.
- Tighten the flare nut with a torque wrench in the specified manner.  
Excessive tightening of the flare nut may cause a crack in the flare nut after a long period, which may result in refrigerant leakage.
- Wear heavy gloves during the installation work to avoid injury.

## 2 Accessory parts

Part name	Q'ty	Shape	Usage
Installation Manual	1	This manual	(Hand over to customers)
Heat insulating pipe	2		For heat insulation of pipe connecting section
Bushing	1		For protection of edge at control wire taking-in port

## 3 Selection of installation place

### Avoid installing in the following places.

Select a location for the indoor unit where the cool or warm air will circulate evenly.

Avoid installation in the following locations.

- Saline area (coastal area).
- Locations with acidic or alkaline atmospheres (such as areas with hot springs, factories where chemicals or pharmaceuticals are made and places where the exhaust air from combustion appliances will be sucked into the unit).  
Doing so may cause the heat exchanger (its aluminum fins and copper pipes) and other parts to become corroded.
- Locations with atmospheres consisting of mist of cutting oil or other types of machine oil.  
Doing so may cause the heat exchanger to become corroded, mists caused by the blockage of the heat exchanger to be generated, the plastic parts to be damaged, the heat insulators to peel off, and other such problems to result.
- Locations where vapors from food oils are formed (such as kitchens where food oils are used).  
Blocked filters may cause the air conditioner's performance to deteriorate, condensation to form, the plastic parts to be damaged, and other such problems to result.
- Locations near obstructions such as ventilation openings or lighting fixtures where the flow of the blown air will be disrupted (a disruption of the air flow may cause the air conditioner's performance to deteriorate or the unit to shut down).
- Locations where an in-house power generator is used for the power supply.  
The power line frequency and voltage may fluctuate, and the air conditioner may not work properly as a result.
- On truck cranes, ships or other moving conveyances.
- The air conditioner must not be used for special applications (such as for storing food, plants, precision instruments or art works).  
(The quality of the items stored may be degraded.)
- Locations where high frequencies are generated (by inverter equipment, in-house power generators, medical equipment or communication equipment).  
(Malfunctioning or control trouble in the air conditioner or noise may adversely affect the equipment's operation.)
- Locations where there is anything under the unit installed that would be compromised by wetness.  
(If the drain has become blocked or when the humidity is over 80%, condensation from the indoor unit will drip, possibly causing damage to anything underneath.)
- In the case of the wireless type of system, rooms with the inverter type of fluorescent lighting or locations exposed to direct sunlight.  
(The signals from the wireless remote control may not be sensed.)
- Locations where organic solvents are being used.
- The air conditioner cannot be used for liquefied carbonic acid cooling or in chemical plants.
- Location near doors or windows where the air conditioner may come into contact with high-temperature, high-humidity outdoor air.  
(Condensation may occur as a result.)
- Locations where special sprays are used frequently.

### ■ Installation space

Unit: in (mm)

Reserve sufficient space required for installation or service work.

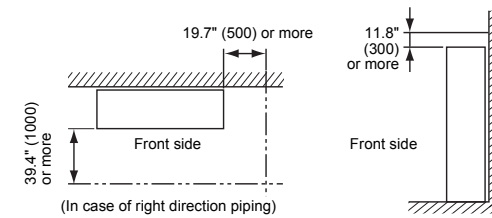

### ■ Filter cleaning sign term setting

The lighting term setup of the filter sign (Notification of filter cleaning) of the remote control can be changed according to the condition of installation.

For setup method, refer to "Filter sign setting" in the Applicable controls of this Manual.

# 4 Installation

## ⚠ CAUTION

- Strictly comply with the following rules to prevent damage of the indoor units and human injury.
- Do not put a heavy article on the indoor unit or let a person get on it. (Even units are packaged)
  - Carry in the indoor unit as it is packaged if possible. If it is necessary to carry the indoor unit unpacked, then use buffering cloth or other material so as to not damage the unit.
  - To move the indoor unit, hold the bottom face of the unit only. Do not apply force to the other parts (refrigerant pipe, drain pan, foamed parts, resin parts or other parts).
  - Have two or more people carry the package, and do not bundle it with plastic band at positions other than specified.

Install an indoor unit as described below.

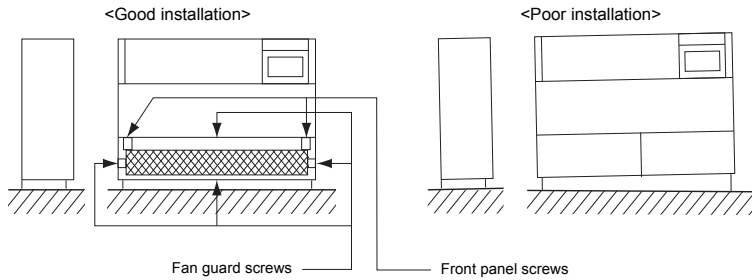

- 1 Remove the air intake grille (4 hooks at top and bottom each)
- 2 Remove the fan guard (4 screws) for piping work.
- 3 Remove the front panel (2 screws) for wiring work

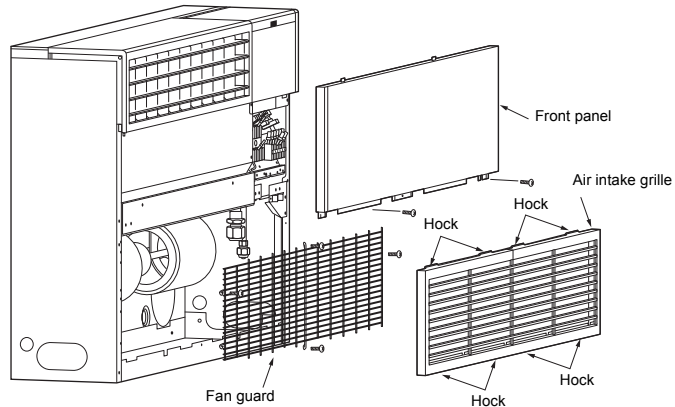

- 4 Start piping and wiring works.
- 5 Keep the front space of the indoor unit as wide as possible. A wide space is required for maintenance and service works as then it is useful for distributing cool / hot air in the room resulting in increase of cooling / heating effect.
- 6 Install the indoor unit horizontally or slanting a little rightward viewed from the front side.

## ■ External dimensions

Unit: in (mm)

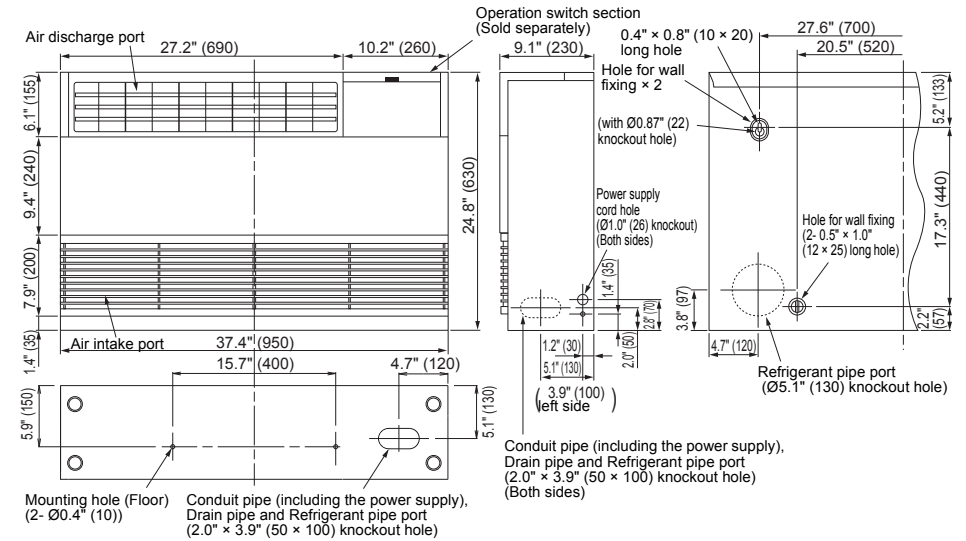

Mounting hole (Floor) (2- $\varnothing 0.4$ " (10))  
Conduit pipe (including the power supply),  
Drain pipe and Refrigerant pipe port  
(2.0" x 3.9" (50 x 100) knockout hole)

Conduit pipe (including the power supply),  
Drain pipe and Refrigerant pipe port  
(2.0" x 3.9" (50 x 100) knockout hole)  
(Both sides)

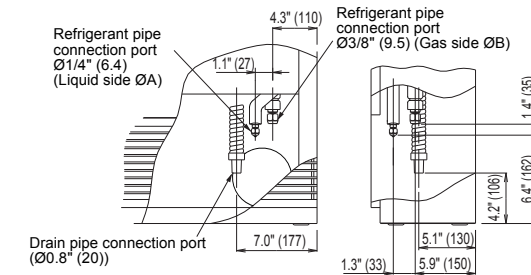

Piping positional drawing

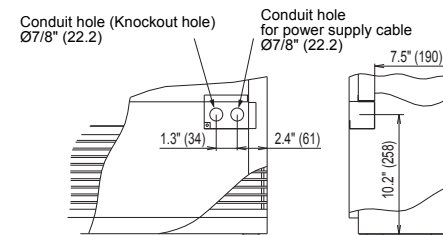

Conduit hole positional drawing

### Dimensions

Model	A	B
AP007, AP009, AP012 type	$\varnothing 1/4$ " (6.4)	$\varnothing 3/8$ " (9.5)
AP015, AP018 type	$\varnothing 1/4$ " (6.4)	$\varnothing 1/2$ " (12.7)
AP024 type	$\varnothing 3/8$ " (9.5)	$\varnothing 5/8$ " (15.9)

## ■ Fixing the indoor unit to wall

Fix the indoor unit to the wall as described below.

- 1 Fix four 0.3" (M8) anchor bolts to the wall, as shown in the following figure.
- 2 Attach the bolts carefully to the upper two anchor bolts, as shown in the following figure.
- 3 Open the knockout hole at rear side of the indoor unit with a screwdriver.
- 4 Hang the indoor unit to the anchor bolts.
- 5 Tighten the nuts to the two lower anchor bolts.

Unit: in (mm)

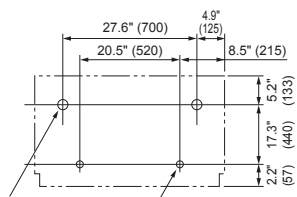

Mount the upper two nuts as shown in the figure below. Tighten the lower two nuts after the unit has been mounted.

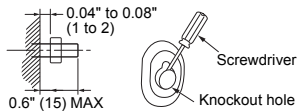

## ■ Fixing the indoor unit to floor

To fix the indoor unit to the floor, pass two anchor bolts attached on the floor through a hole of the bottom plate of the indoor unit. Tighten and fix it with the nuts.

Unit: in (mm)

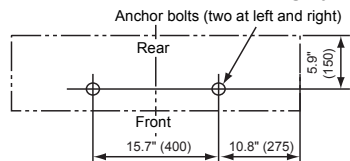

## ■ Installation of remote control (Sold separately)

For installation of the wired remote control, follow the Installation Manual attached with the remote control.

- Pull out the remote control cord together with the refrigerant pipe or drain pipe. Pass the remote control cord through upper side of the refrigerant pipe and drain pipe.
- Do not leave the remote control at a place exposed to direct sunlight and near a stove.

## ■ Wireless remote control

The sensor of indoor unit with wireless remote control can receive a signal from a distance within approx. 23' (7 m). Based on this, determine a place where the remote control can be operated and the installation place.

- Operate the remote control, confirm that the indoor unit receives a signal, and then install it.
- Keep it 3.3' (1 m) or more from devices such as television, stereo etc. (Disturbance of image or noise may generate.)
- To prevent malfunction, select a place away from fluorescent light or direct sunlight.
- Two indoor units with wireless type remote control can be installed in the same room.

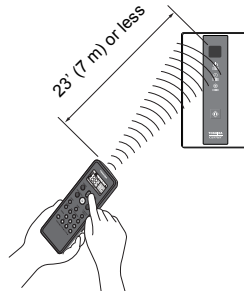

# 5 Drain piping

### ⚠ CAUTION

- Following the Installation Manual, perform the drain piping work so that water is properly drained. Apply a heat insulation so as not to cause a dew condensation. Inappropriate piping work may result in water leakage in the room and wet furniture.
- After opening the knockout hole, deburr the edge. Burrs adhered to opening of the knockout hole may cause an injury by touching it.
- Provide the indoor drain piping with proper heat insulation.
- Provide the area where the pipe connects to the indoor unit with proper heat insulation. Improper heat insulation will cause condensation to form.
- The drain pipe must be sloping downward (at an angle of 1/100 or more), and do not run the pipe up and down (arched shape) or allow it to form traps. Doing so may cause abnormal sounds.
- Restrict the length of the traversing drain pipe to 65.6' (20 m) or less. For a long pipe, provide support brackets at intervals of 4'11" to 6'7" (1.5 to 2 m) to prevent flapping.
- Install the collective piping as shown in the following figure.
- Do not provide any air vents. Otherwise, the drain water will spout, causing water to leak.
- Do not allow any force to be applied to the connection area with the drain pipe.

## ■ Pipe material, size and insulator

The following materials for piping work and insulating process are procured locally.

Pipe material	Hard vinyl chloride pipe, pipe elbow (Nominal inner diameter Ø0.8" (20 mm))
Insulator	Foamed polyethylene foam, thickness: 0.4" (10mm) or more

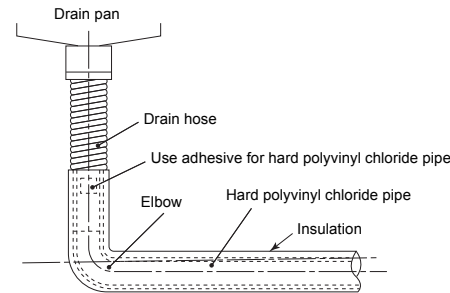

## ■ Piping method

The drain pipe and the refrigerant pipe can be connected to left, right, rear or bottom side arbitrarily depending on the installation location.

Select a set knockout hole referring to the following figure.

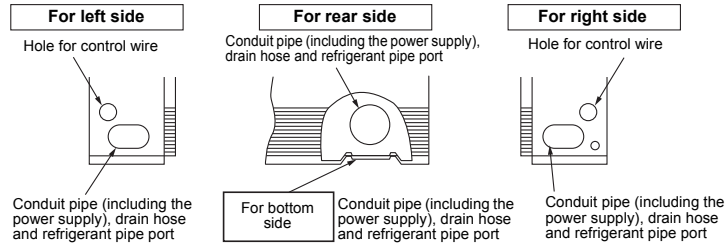

## ■ Connecting drain pipe

Insert the drain hose into the connector until the hose can go no farther.

### REQUIREMENT

- Connect the hard vinyl chloride pipes by using adhesive agents for vinyl chloride so that water does not leak.
- It takes some time to dry and indurate the adhesive agent. (Refer to the manual of adhesive agent.) Do not apply any extra force on the connecting section until the adhesive agent is dried.

## ■ Check the draining

- In the test run, check that water drain is properly performed and that water does not leak from the connecting part of the pipes. Check draining also when installed in heating period.
- Remove the cover from the bottom side of the heat exchanger. Pour water to the drain pan. Confirm that water drains well and does not leak from the drain hose connecting part.
- Once the drain is confirmed, attach back the cover in the way it was.

### CAUTION

#### Water must be poured slowly.

If water is swiftly poured, water may spatter across the inside of the indoor unit. It may cause malfunction of the unit.

# 6 Refrigerant piping

### CAUTION

When the refrigerant pipe is long, provide support brackets at intervals of 8'2" to 9'10" (2.5 to 3 m) to clamp the refrigerant pipe. Otherwise, abnormal sound may be generated.  
Use the flare nut attached with the indoor unit or R410A flare nut.

## ■ Permissible piping length and height difference

They vary depending on the outdoor unit. For details, refer to the Installation Manual attached to the outdoor unit.

## ■ Pipe size

Unit: in (mm)

Model MML-	Pipe size	
	Gas side	Liquid side
AP007 to AP012	3/8" (9.5)	1/4" (6.4)
AP015, AP018	1/2" (12.7)	1/4" (6.4)
AP024	5/8" (15.9)	3/8" (9.5)

## ■ Connecting refrigerant piping

### Flaring

#### 1 Cut the pipe with a pipe cutter.

Remove burrs completely. (Remaining burrs may cause gas leakage.)

#### 2 Insert a flare nut into the pipe, and flare the pipe.

Use the flare nut provided with the unit or the one used for the R410A refrigerant. The flaring dimensions for R410A are different from the ones used for the conventional R22 refrigerant. A new flare tool manufactured for use with the R410A refrigerant is recommended, but the conventional tool can still be used if the projection margin of the copper pipe is adjusted to be as shown in the following table.

### Projection margin in flaring: B

Unit: in (mm)

Outer dia. of copper pipe	R410A tool used	Conventional tool used
1/4" to 5/8" (6.4 to 15.9)	0 to 0.02" (0 to 0.5)	0.04" to 0.06" (1.0 to 1.5)

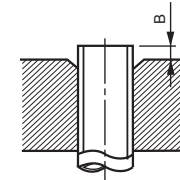

### Flaring diameter size: A

Unit: in (mm)

Outer dia. of copper pipe	A <sup>+0</sup> / <sub>-0.02"</sub> (0.4)
1/4" (6.4)	0.36" (9.1)
3/8" (9.5)	0.52" (13.2)
1/2" (12.7)	0.65" (16.6)
5/8" (15.9)	0.78" (19.7)

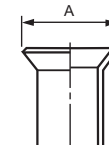

\* In case of flaring for R410A with the conventional flare tool, pull it out approx. 0.02" (0.5 mm) more than that for R22 to adjust to the specified flare size. The copper pipe gauge is useful for adjusting projection margin size.

- The sealed gas was sealed at the atmospheric pressure so when the flare nut is removed, there will be no "whooshing" sound: This is normal and is not indicative of trouble.
- Use two spanners to connect the indoor unit pipe.

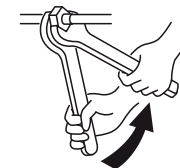

Work using two spanners

- Use the tightening torque levels as listed in the following table.

Outer dia. of connecting pipe (in (mm))	Tightening torque (ft•lbs (N•m))
1/4" (6.4)	10 to 13 (14 to 18)
3/8" (9.5)	24 to 31 (33 to 42)
1/2" (12.7)	37 to 46 (50 to 62)
5/8" (15.9)	46 to 57 (63 to 77)

- Tightening torque of flare pipe connections. Pressure of R410A is higher than that of R22. (Approx. 1.6 times) Therefore, using a torque wrench, tighten the flare pipe connecting sections which connect the indoor and outdoor units of the specified tightening torque. Incorrect connections may cause not only a gas leak, but also a trouble of the refrigeration cycle.

**CAUTION**

Tightening with an excessive torque may crack the nut depending on installation conditions.

**Airtight test / air purge, etc.**

For air tightness test, adding refrigerant, refer to the Installation Manual attached to the outdoor unit.

**CAUTION**

Do not supply power to the indoor unit until the airtight test and vacuuming are completed. (If the indoor unit is powered on, the pulse motor valve is fully closed, which extends the time for vacuuming.)

**Open the valve fully**

Open the valve of the outdoor unit fully.

**Heat insulation process**

Apply heat insulation for the pipes separately at liquid side and gas side.

- For the heat insulation to the pipes at gas side, use the material with heat-resisting temperature 248 °F (120 °C) or higher.
- To use the attached heat insulation pipe, apply the heat insulation to the pipe connecting section of the indoor unit securely without gap.

**REQUIREMENT**

Insulate the refrigerant pipe in the indoor unit securely up to the point shown in the following figure.

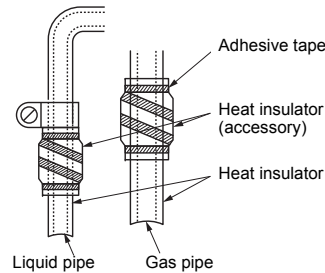

# 7 Electrical connection

**WARNING**

- Use predefined wire and connect them certainly. Keep the connecting terminal free from external force.**  
Improper wire connection or clamping may result in exothermic, fire or malfunction.
- Connect ground wire. (grounding work)**  
Incomplete grounding cause an electric shock. Do not connect ground wires to gas pipes, water pipes, lightning rods or ground wires for telephone wires.
- Install appliance in accordance with national wiring regulations.**  
Capacity shortage of circuit breaker or incomplete installation may cause an electric shock or a fire.

**CAUTION**

- Consult local building codes, NEC (National Electrical Code) or CEC (Canadian Electrical Code) for special requirements.
- If incorrect / incomplete wiring is carried out, it will cause an electrical fire or smoke.
- If circuit breaker is not installed, an electric shock may be caused.
- Use the cord clamps attached to the product.
- Do not damage or scratch the conductive core and inner insulator of power and control wires when peeling them.
- Use the power cord and control wire of specified thickness, type, and protective devices required.
- Do not connect 208 / 230 V power to the terminal blocks (U1, U2, A, B etc.) for control wiring. (Otherwise, the system will fail.)
- Perform the electric wiring so that it does not come to contact with the high-temperature part of the pipe. The coating may melt resulting in an accident.
- Do not turn on the circuit breaker of the indoor unit until vacuuming of the refrigerant pipes is completed.

**REQUIREMENT**

- For power supply wiring, strictly conform to the Local Regulation in each country.
- Run the refrigerant piping line and control wiring line in the same line.

**Power supply wire and control wires specifications**

Power supply wire and control wires are locally procured. For the power supply specifications, follow the table below. If the capacity is too low, overheat or seizure may occur.

**Indoor unit power supply**

For the power supply of the indoor unit, prepare the exclusive power supply separated from that of the outdoor unit.

**Power supply**

Power supply	208 / 230-1-60
--------------	----------------

**Control wiring, Central control wiring**

- 2-core with non-polarity wires are used for the control wiring between indoor unit and outdoor unit and Central control wiring.
- To prevent noise trouble, use 2-core shielded wire.
- The length of the communication line means the total length of the control wire length between indoor and outdoor units added with the central control wire length.



## Power supply wire

Recommended wire diameter and wire length for power supply wire.

Power supply wiring	Wire size: 2 × AWG12 Ground 1 × AWG12 or thicker	Up to 164'1" (50 m)
---------------------	---	---------------------

## ▼ Electric characteristics

MCA : Minimum Circuit Amps  
MOCP : Maximum Overcurrent Protection (Amps)

Model	Power Supply	Voltage Range (V)		MCA (A)	MOCP (A)
		Min	Max		
MML-AP0074H2UL	208 / 230 V-1-60 Hz	187	253	0.4	15
MML-AP0094H2UL				0.4	15
MML-AP0124H2UL				0.6	15
MML-AP0154H2UL				0.6	15
MML-AP0184H2UL				0.7	15
MML-AP0244H2UL				0.7	15

## Control wire

Control wiring between indoor units, and outdoor unit (2-core shielded wire)	Wire size	(Up to 3280'10" (1000 m)) AWG16 (Up to 6561'8" (2000 m)) AWG14
--	-----------	---

## Remote control wiring

2-core with non-polarity wire is used for wiring of the remote control wiring and group remote controls wiring.

Remote control wiring, remote control inter-unit wiring	Wire size: AWG20	
Total wire length of remote control wiring and remote control inter-unit wiring = L + L1 + L2 + ... Ln	In case of wired type only	Up to 1640'5" (500 m)
	In case of wireless type included	Up to 1312'4" (400 m)
Total wire length of remote control inter-unit wiring = L1 + L2 + ... Ln		Up to 656'2" (200 m)

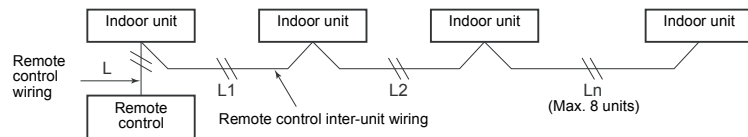

## NOTE

- Use copper supply wire.
- Use UL wire rated 600 V for the power supply.
- Use UL wire rated 300 V for the remote control wires and control wires.

## ⚠ CAUTION

Do not put the remote control wires and power supply wires (AC208 / 230 V) in the same conduit. Doing so may cause trouble in the control system due to noise or other factors.

## ■ Wiring between indoor and outdoor units

### NOTE

An outdoor unit connected with control wiring between indoor and outdoor units wire becomes automatically the header outdoor unit.

### ▼ Wiring example

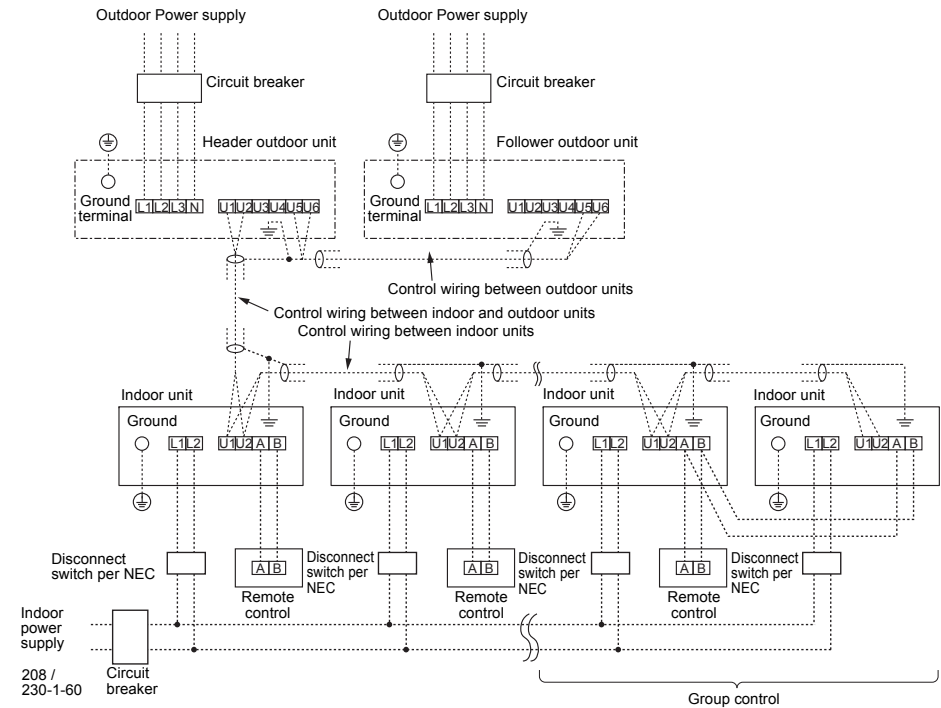

## ■ Wire connection

### REQUIREMENT

- Connect the wires matching the terminal numbers. Incorrect connection can cause problems.
- Pass the wires through the bushing of wire connection holes of the indoor unit.
- Keep a margin (Approx. 3.9" (100 mm)) on a wire to hang down the electrical control box for servicing or other purpose.
- The low-voltage circuit is provided for the remote control. (Do not connect it to high-voltage circuit)
- Run the power supply wire through a conduit pipe up to the conduit mounting plate in the indoor unit. (It is recommended to use a flexible conduit pipe.)
- Draw in the wire from the pipe hole (Knockout hole).
- Provide adequate length to the wire and fix it with cord clamp as shown in the figure.

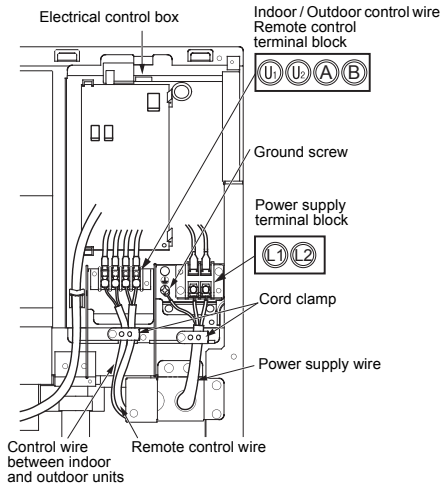

Unit: in (mm)

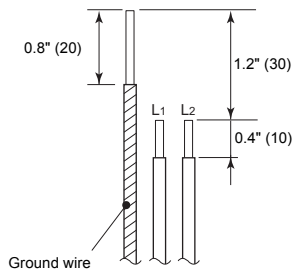

## ⚠ CAUTION

Firmly tighten the screws of the terminal block.

Keep the wire length as shown in figure below when it is connected to the terminal block.

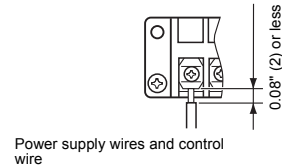

## ■ Remote control wiring

Strip off approx. 0.4" (9 mm) the wire to be connected.

### ▼ Wiring diagram

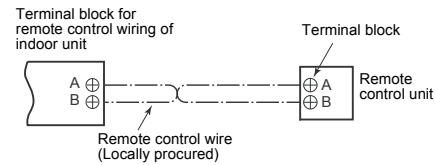

## ■ Address setup

Set up the addresses as per the Installation Manual supplied with the outdoor unit.

## ■ Installation procedure for Single port type Flow Selector unit

**1** Remove the two fixing screws inside of the discharge port.

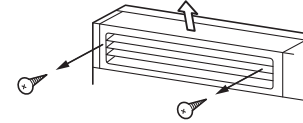

**2** Insert your hand into the discharge port, push up the back side a little, and then remove the discharge port from the hooks at rear side.

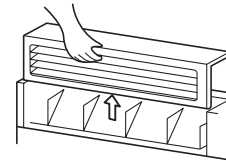

**3** Remove the 3 screws that fix the switch box.

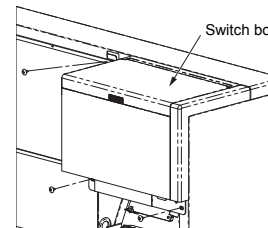

**4** Slightly lift up the front of the switch box and remove it by pushing toward the top while keeping it tilted.

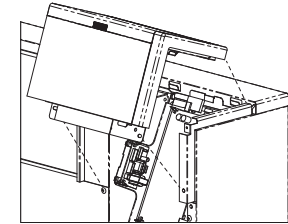

**5** Connect the Power supply and communication lead wire of the Single port type Flow Selector unit to CN081.

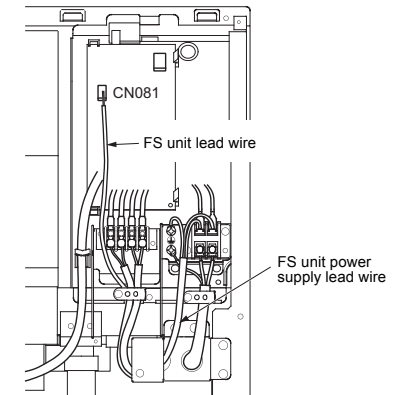

# 8 Applicable controls

## REQUIREMENT

When the air conditioner is used for the first time, it will take some time after the power has been turned on before the remote control becomes available for operations: This is normal and is not indicative of any problems.

- Concerning the automatic addresses (The automatic addresses are set up by performing operations on the outdoor interface circuit board.)

While the automatic addresses are being set up, no remote control operations can be performed. Setup takes up to 10 minutes (usually about 5 minutes).

- When the power is turned on after automatic address setup it takes up to 10 minutes (usually about 3 minutes) for the outdoor unit to start operating after the power has been turned on.

Before the air conditioner is shipped from the factory, all units are set to [STANDARD] (factory default). If necessary, change the indoor unit settings.

The settings are changed by operating the wired remote control.

- \* The settings cannot be changed by using only a wireless remote control, simple remote control or group control remote control by itself so install a wired remote control separately as well.

## Basic procedure for changing settings

Change the settings while the air conditioner is not working. **(Stop the air conditioner before changing the settings.)**

### CAUTION

Set only the CODE No. shown in the following table: Do NOT set any other CODE No.

If a CODE No. not listed is set, it may not be possible to operate the air conditioner or other troubles with the product may result.

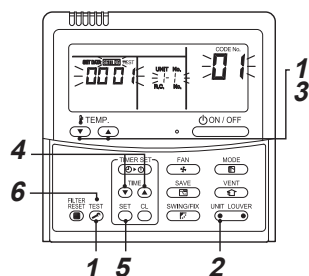

- 1 Push and hold **TEST** button and “TEMP.” button simultaneously for at least 4 seconds. After a while, the display flashes as shown in the figure. Confirm that the CODE No. is [01].

If the CODE No. is not [01], push **TEST** button to clear the display content, and repeat the procedure from the beginning. (No operation of the **TEST** remote control is accepted for a while after button is pushed.)

(While air conditioners are operated under the group control, “ALL” is displayed first. When **UNIT LOUVER** is pushed, the indoor unit number displayed following “ALL” is the header unit.)

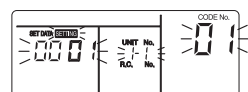

(\* Display content varies with the indoor unit model.)

- 2 Each time **UNIT LOUVER** button is pushed, indoor unit numbers in the control group change cyclically. Select the indoor unit to change settings for.

The fan of the selected unit runs and the louvers start swinging. The indoor unit for change settings can be confirmed.

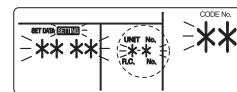

- 3 Specify CODE No. [\*\*] with “TEMP.” / buttons.

- 4 Select SET DATA [\*\*\*\*] with “TIME” / buttons.

- 5 Push **SET** button. When the display changes from flashing to lit, the setup is completed.

- To change settings of another indoor unit, repeat from Procedure 2.
- To change other settings of the selected indoor unit, repeat from Procedure 3.

Use **SET** button to clear the settings. To make settings after **SET** button was pushed, repeat from Procedure 2.

- 6 When settings have been completed, push **TEST** button to determine the settings.

When **TEST** button is pushed, **SETTING** flashes and then the display content disappears and the air conditioner enters the normal stop mode.

(While **SETTING** is flashing, no operation of the remote control is accepted.)

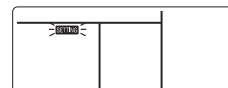

## Filter sign setting

According to the installation condition, the filter sign term (Notification of filter cleaning) can be changed. Follow to the basic operation procedure (1 → 2 → 3 → 4 → 5 → 6).

- For the CODE No. in Procedure 3, specify [01].
- For the [SET DATA] in Procedure 4, select the SET DATA of filter sign term from the following table.

SET DATA	Filter sign term
0000	None
0001	150 H (Factory default)
0002	2500 H
0003	5000 H
0004	10000 H

## To secure better effect of heating

When it is difficult to obtain satisfactory heating due to installation place of the indoor unit or structure of the room, the detection temperature of heating can be raised. Also use a circulator or other machinery to circulate heat air near the ceiling.

Follow to the basic operation procedure (1 → 2 → 3 → 4 → 5 → 6).

- For the CODE No. in Procedure 3, specify [06].
- For the set data in Procedure 4, select the SET DATA of shift value of detection temperature to be set up from the following table.

SET DATA	Detection temperature shift value
0000	No shift (Factory default)
0001	+1.8 °F (+1 °C)
0002	+3.6 °F (+2 °C)
0003	+5.4 °F (+3 °C)
0004	+7.2 °F (+4 °C)
0005	+9.0 °F (+5 °C)
0006	+10.8 °F (+6 °C)

## ■ Remote control sensor

The temperature sensor of the indoor unit senses room temperature usually. Set the remote control sensor to sense the temperature around the remote control.

Select items following the basic operation procedure (1 → 2 → 3 → 4 → 5 → 6).

- Specify [32] for the CODE No. in Procedure 3.
- Select the following data for the SET DATA in Procedure 4.

SET DATA	0000	0001
Remote control sensor	Not used (Factory default)	Used

When  flashes, the remote control sensor is defective.

Select the SET DATA [0000] (not used) or replace the remote control.

## ■ Group control

In a group control, a remote control can control up to maximum 8 units.

- The wired remote control only can control a group control. The wireless remote control is unavailable for this control.
- For wiring procedure and wires of the individual line (Identical refrigerant line) system, refer to "Electrical Connection" in this Manual.
- Wiring between indoor units in a group is performed in the following procedure.
- Connect the indoor units by connecting the remote control wires from the remote control terminal blocks (A, B) of the indoor unit connected with a remote control to the remote control terminal blocks (A, B) of the other indoor unit. (Non-polarity)
- For address setup, refer to the Installation Manual attached to the outdoor unit.

# 9 How to change the discharge port

The air discharging direction of the indoor unit has been set to forward direction as factory default.

However it is possible to change to upward direction.

Change the discharging direction according to conditions of the room or requirement by the customers.

### In cooling operation

In cooling operation, use the air conditioner with upward direction of air discharge so that cold air is spread over the whole room.



### In heating operation

In heating operation, use the air conditioner with downward direction of air discharge so that hot air reaches at the foot.



- 1 Remove the two fixing screws inside of the discharge port.

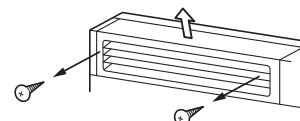

- 2 Insert your hand into the discharge port, push up the back side a little, and then remove the discharge port from the hooks at rear side.

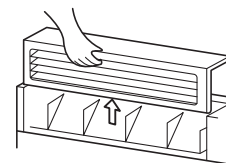

- 3 Lift up the discharge port upward and remove it.

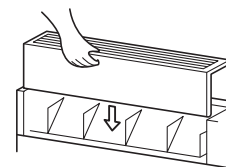

- 4 Upend the discharge port and mount it to the indoor unit. To mount the discharge port, hook the four hooks (two at rear and bottom side each).

- 5 Fix the discharge port with the removed fixing screws securely.

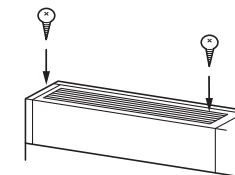

### CAUTION

Do not drop the fixing screws to the inside of the unit.

# 10 Test run

## ■ Before test run

- Before turning on the power supply, carry out the following procedure.
  - 1) By using 500 V-megger, check that resistance of 1 MΩ or more exists between the terminal block L to N and the ground.  
If resistance of less than 1 MΩ is detected, do not run the unit.
  - 2) Check the valve of the outdoor unit being opened fully.
- To protect the compressor at activation time, leave power-ON for 12 hours or more before operating.
- Do not press the electromagnetic contactor to forcibly perform a test run. (This is very dangerous in case the protective device does not work.)
- Before starting a test run, set addresses by following the Installation Manual supplied with the outdoor unit.

## ■ Execute a test run

- When a fan operation is to be performed for an individual indoor unit, turn off the power, short CN72 on the circuit board, and then turn the power back on. (First set the operating mode to “fan,” and then operate.) When the test run has been performed using this method, do NOT forget to release the shorting of CN72 after the test run is completed.

Operate the unit with the wired remote control as usual. For the procedure of the operation, refer to the attached to the outdoor unit Owner's Manual.

A forced test run can be executed in the following procedure even if the operation stops by turning the thermostat - OFF.

In order to prevent a serial operation, the forced test run is released after 60 minutes have passed and returns to the usual operation.

### ⚠ CAUTION

Do not use the forced test run for cases other than the test run because it applies an excessive load to the devices.

## Wired remote control

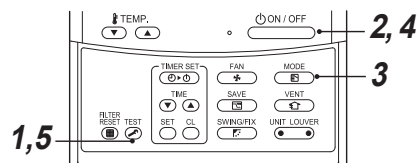

- 1 Push **TEST** button for 4 seconds or more. [TEST] is displayed on the display part and the selection of mode in the test mode is permitted.

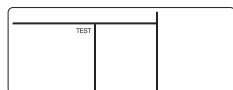

- 2 Push **ON/OFF** button.

- 3 Select the operation mode with **MODE** button, [**Cool**] or [**Heat**].
  - Do not run the air conditioner in a mode other than [**Cool**] or [**Heat**].
  - The temperature controlling function does not work during test run.
  - The detection of error is performed as usual.

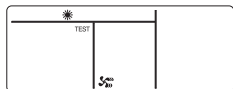

- 4 After the test run, push **ON/OFF** button to stop a test run. (Display part is same as procedure 1.)

- 5 Push **TEST** button to cancel (release from) the test run mode. ([TEST] disappears on the display and the status returns to a normal.)

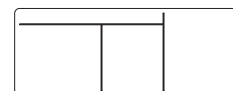

## Wireless remote control

(TCB-AX32-UL)

- 1 When **TEMPORARY** button is pushed for 10 seconds or more, “Pi!” sound is heard and the operation changes to a forced cooling operation. After approx. 3 minutes, a cooling operation starts forcibly. Check cool air starts blowing. If the operation does not start, check wiring again.
- 2 To stop a test operation, push **TEMPORARY** button once again (Approx. 1 second).
  - Check wiring / piping of the indoor and outdoor units in forced cooling operation.

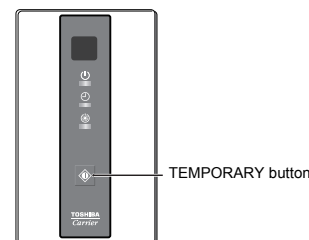

# 11 Maintenance

## <Daily maintenance>

### ▼ Cleaning of air filter

If  is displayed on the remote control, maintain the air filter.

- 1 Push the  button to stop the operation, then turn off the circuit breaker.

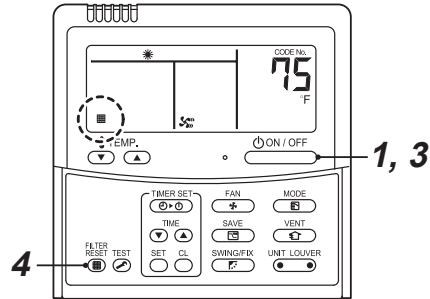

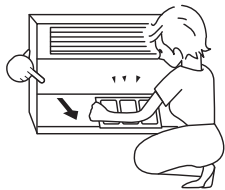

- 2 Take out the air filter.

- Push down the upper part of the air intake grille slightly, and then pull it toward you to remove it.
- Take out the air filter inside the air intake grille.



- Cleaning with water or vacuum cleaner
- If dirt is heavy, clean the air filter by tepid water with neutral detergent or water.
- After cleaning with water, dry the air filter sufficiently in a shade place.
- Mount the air filter.

- 3 Turn on the circuit breaker, then push the  button on the remote control to start the operation.

- 4 After cleaning, push .  display disappears.

### ⚠ CAUTION

- Do not start the air conditioner while leaving air filter removed.
- Push the filter reset button. ( indication will be turn off.)

# 12 Troubleshooting

## ■ Confirmation and check

When an error occurs in the air conditioner, an error code and indoor UNIT No. appear on the display part of the remote control.  
The error code is only displayed during the operation.  
If the display disappears, operate the air conditioner according to the following "Confirmation of error log" for confirmation.

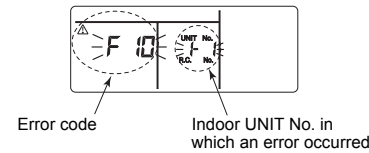

## ■ Confirmation of error log

When an error occurs on the air conditioner, the error log can be confirmed with the following procedure.  
(The error log is stored in memory up to 4 errors.)  
The log can be confirmed from both operating status and stop status.

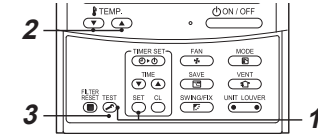

- 1 When  and  buttons are pushed simultaneously for 4 seconds or more, the following display appears.

If  is displayed, the mode enters in the error log mode.

- [01: Order of error log] is displayed in CODE No.
- [Error code] is displayed in CHECK.
- [Indoor unit address in which an error occurred] is displayed in Unit No..

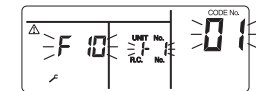

- 2 Every pushing of  button used to set temperature, the error log stored in memory is displayed in order.

The numbers in CODE No. indicate CODE No.  
[01] (latest) → [04] (oldest).

### REQUIREMENT

Do not push  button because all the error log of the indoor unit will be deleted.

- 3 After confirmation, push  button to return to the usual display.

## ■ Check codes and parts to be checked

### Check method

On the remote control (Wired remote control, Central control remote control) and the interface P.C. board of the outdoor unit (I/F), a check display LCD (Remote control) or 7-segment display (on the outdoor interface P.C. board) to display the operation is provided. Therefore the operation status can be known. With this self-diagnosis function, a trouble or position with error of the air conditioner can be found as shown in the table below.

### Check code list

The following list shows each check code. Find the check contents from the list according to part to be checked.

- To check from indoor remote control: See "Wired remote control display" in the list.
- To check from outdoor unit: See "Outdoor 7-segment display" in the list.
- To check from indoor unit with a wireless remote control: See "Sensor block display of receiving unit" in the list.

IPDU : Intelligent Power Drive Unit  
 ○ : Lighting, ◻ : Flashing, ● : Goes off  
 ALT : Flashing is alternately when there are two flashing LED.  
 SIM : Simultaneous flashing when there are two flashing LED.

Check code		Wireless remote control				Check code name	Judging device
Wired remote control display	Outdoor 7-segment display	Sensor block display of receiving unit					
	Auxiliary code	Operation	Timer	Ready	Flash		
E01	—	—	◻	●	●	Communication error between indoor and remote control (Detected at remote control side)	Remote control
E02	—	—	◻	●	●	Remote control transmission error	Remote control
E03	—	—	◻	●	●	Communication error between indoor and remote control (Detected at indoor side)	Indoor
E04	—	—	●	●	◻	Communication circuit error between indoor / outdoor (Detected at indoor side)	Indoor
E06	E06	No. of indoor units in which sensor has been normally received	●	●	◻	Decrease of No. of indoor units	I/F
—	E07	—	●	●	◻	Communication circuit error between indoor / outdoor (Detected at outdoor side)	I/F
E08	E08	Duplicated indoor addresses	◻	●	●	Duplicated indoor addresses	Indoor / I/F
E09	—	—	◻	●	●	Duplicated header remote controls	Remote control
E10	—	—	◻	●	●	Communication error between indoor MCU	Indoor
E12	E12	01: Indoor / Outdoor communication 02: Communication between outdoor units	◻	●	●	Automatic address start error	I/F
E15	E15	—	●	●	◻	Indoor is nothing during automatic addressing	I/F
E16	E16	00: Capacity over 01 ~:No. of connected units	●	●	◻	Capacity over / No. of connected indoor units Combined capacity of indoor units exceeds 120% of combined capacity of outdoor units.	I/F
E18	—	—	◻	●	●	Communication error between indoor units	Indoor
E19	E19	00: Header is nothing 02: Two or more header units	●	●	◻	Outdoor header units quantity error	I/F
E20	E20	01: Outdoor of other line connected 02: Indoor of other line connected	●	●	◻	Other line connected during automatic address	I/F
E23	E23	—	●	●	◻	Sending error in communication between outdoor units	I/F
E25	E25	—	●	●	◻	Duplicated follower outdoor addresses	I/F
E26	E26	No. of outdoor units which received signal normally	●	●	◻	Decrease of No. of connected outdoor units	I/F
E28	E28	Detected outdoor unit number	●	●	◻	Follower outdoor unit error	I/F

Check code		Wireless remote control				Check code name	Judging device																																																																																												
Wired remote control display	Outdoor 7-segment display	Sensor block display of receiving unit																																																																																																	
	Auxiliary code	Operation	Timer	Ready	Flash																																																																																														
E31	E31	<table border="1"> <tr> <td></td> <td colspan="3">A3-IPDU</td> <td rowspan="2">Fan IPDU</td> </tr> <tr> <td></td> <td>1</td> <td>2</td> <td>3</td> </tr> <tr> <td>01</td> <td>○</td> <td></td> <td></td> <td></td> </tr> <tr> <td>02</td> <td></td> <td>○</td> <td></td> <td></td> </tr> <tr> <td>03</td> <td>○</td> <td>○</td> <td></td> <td></td> </tr> <tr> <td>04</td> <td></td> <td></td> <td>○</td> <td></td> </tr> <tr> <td>05</td> <td>○</td> <td></td> <td>○</td> <td></td> </tr> <tr> <td>06</td> <td></td> <td>○</td> <td>○</td> <td></td> </tr> <tr> <td>07</td> <td>○</td> <td>○</td> <td>○</td> <td></td> </tr> <tr> <td>08</td> <td></td> <td></td> <td></td> <td>○</td> </tr> <tr> <td>09</td> <td>○</td> <td></td> <td></td> <td>○</td> </tr> <tr> <td>0A</td> <td></td> <td>○</td> <td></td> <td>○</td> </tr> <tr> <td>0B</td> <td>○</td> <td>○</td> <td></td> <td>○</td> </tr> <tr> <td>0C</td> <td></td> <td></td> <td>○</td> <td>○</td> </tr> <tr> <td>0D</td> <td>○</td> <td></td> <td>○</td> <td>○</td> </tr> <tr> <td>0E</td> <td></td> <td>○</td> <td>○</td> <td>○</td> </tr> <tr> <td>0F</td> <td>○</td> <td>○</td> <td>○</td> <td>○</td> </tr> <tr> <td colspan="5">○ : IPDU error</td> </tr> </table>					A3-IPDU			Fan IPDU		1	2	3	01	○				02		○			03	○	○			04			○		05	○		○		06		○	○		07	○	○	○		08				○	09	○			○	0A		○		○	0B	○	○		○	0C			○	○	0D	○		○	○	0E		○	○	○	0F	○	○	○	○	○ : IPDU error					●	●	◻	IPDU communication error	I/F
			A3-IPDU			Fan IPDU																																																																																													
			1	2	3																																																																																														
		01	○																																																																																																
		02		○																																																																																															
		03	○	○																																																																																															
		04			○																																																																																														
		05	○		○																																																																																														
		06		○	○																																																																																														
		07	○	○	○																																																																																														
		08				○																																																																																													
		09	○			○																																																																																													
		0A		○		○																																																																																													
		0B	○	○		○																																																																																													
		0C			○	○																																																																																													
		0D	○		○	○																																																																																													
0E		○	○	○																																																																																															
0F	○	○	○	○																																																																																															
○ : IPDU error																																																																																																			
F01	—	—	◻	◻	●	ALT	Indoor TCJ sensor error	Indoor																																																																																											
F02	—	—	◻	◻	●	ALT	Indoor TC2 sensor error	Indoor																																																																																											
F03	—	—	◻	◻	●	ALT	Indoor TC1 sensor error	Indoor																																																																																											
F04	F04	—	◻	◻	○	ALT	TD1 sensor error	I/F																																																																																											
F05	F05	—	◻	◻	○	ALT	TD2 sensor error	I/F																																																																																											
F06	F06	TE1 sensor TE2 sensor	◻	◻	○	ALT	TE1 sensor error TE2 sensor error	I/F																																																																																											
F07	F07	—	◻	◻	○	ALT	TL sensor error	I/F																																																																																											
F08	F08	—	◻	◻	○	ALT	TO sensor error	I/F																																																																																											
F10	—	—	◻	◻	●	ALT	Indoor TA sensor error	Indoor																																																																																											
F12	F12	—	◻	◻	○	ALT	TS1 sensor error	I/F																																																																																											
F13	F13	01: Comp. 1 side 02: Comp. 2 side 03: Comp. 3 side	◻	◻	○	ALT	TH sensor error	IPDU																																																																																											
F15	F15	—	◻	◻	○	ALT	Outdoor temp. sensor miswiring (TE1, TL)	I/F																																																																																											
F16	F16	—	◻	◻	○	ALT	Outdoor pressure sensor miswiring (Pd, Ps)	I/F																																																																																											
F22	F22	—	◻	◻	○	ALT	TD3 error	I/F																																																																																											
F23	F23	—	◻	◻	○	ALT	Ps sensor error	I/F																																																																																											
F24	F24	—	◻	◻	○	ALT	Pd sensor error	I/F																																																																																											
F29	—	—	◻	◻	●	SIM	Indoor other error	Indoor																																																																																											
F31	F31	—	◻	◻	○	SIM	Indoor EEPROM error	I/F																																																																																											
H01	H01	01: Comp. 1 side 02: Comp. 2 side 03: Comp. 3 side	●	◻	●		Compressor break down	IPDU																																																																																											
H02	H02	01: Comp. 1 side 02: Comp. 2 side 03: Comp. 3 side	●	◻	●		Compressor trouble (lock)	IPDU																																																																																											
H03	H03	01: Comp. 1 side 02: Comp. 2 side 03: Comp. 3 side	●	◻	●		Current detect circuit system error	IPDU																																																																																											
H05	H05	—	●	◻	●		TD1 miswiring	I/F																																																																																											
H06	H06	—	●	◻	●		Low pressure protective operation	I/F																																																																																											
H07	H07	—	●	◻	●		Oil level down detective protection	I/F																																																																																											
H08	H08	01: TK1 sensor error 02: TK2 sensor error 03: TK3 sensor error 04: TK4 sensor error	●	◻	●		Oil level detective temp sensor error	I/F																																																																																											
H15	H15	—	●	◻	●		TD2 miswiring	I/F																																																																																											

Check code		Wireless remote control				Check code name	Judging device																																																																								
Wired remote control display	Outdoor 7-segment display	Sensor block display of receiving unit																																																																													
	Auxiliary code	Operation	Timer	Ready	Flash																																																																										
H16	H16	01: TK1 oil circuit system error 02: TK2 oil circuit system error 03: TK3 oil circuit system error 04: TK4 oil circuit system error	●	○	●		Oil level detective circuit error	I/F																																																																							
H25	H25	—	●	○	●		TD3 miswiring	I/F																																																																							
L03	—	—	○	●	○	SIM	Indoor center unit duplicated	Indoor																																																																							
L04	L04	—	○	○	○	SIM	Outdoor line address duplicated	I/F																																																																							
L05	—	—	○	●	○	SIM	Duplicated indoor units with priority (Displayed in indoor unit with priority)	I/F																																																																							
L06	L06	No. of indoor units with priority	○	●	○	SIM	Duplicated indoor units with priority (Displayed in unit other than indoor unit with priority)	I/F																																																																							
L07	—	—	○	●	○	SIM	Group line in individual indoor unit	Indoor																																																																							
L08	L08	—	○	●	○	SIM	Indoor group / Address unset	Indoor, I/F																																																																							
L09	—	—	○	●	○	SIM	Indoor capacity unset	Indoor																																																																							
L10	L10	—	○	○	○	SIM	Outdoor capacity unset	I/F																																																																							
L17	L17	—	○	○	○	SIM	Outdoor unit model unmatched error	I/F																																																																							
L20	—	—	○	○	○	SIM	Duplicated central control addresses	Indoor																																																																							
L28	L28	—	○	○	○	SIM	Over No. of connected outdoor units	I/F																																																																							
L29	L29	<table border="1"> <thead> <tr> <th colspan="3">A3-IPDU</th> <th rowspan="2">Fan IPDU</th> </tr> <tr> <th>1</th> <th>2</th> <th>3</th> </tr> </thead> <tbody> <tr><td>01</td><td>○</td><td></td><td></td></tr> <tr><td>02</td><td></td><td>○</td><td></td></tr> <tr><td>03</td><td>○</td><td>○</td><td></td></tr> <tr><td>04</td><td></td><td></td><td>○</td></tr> <tr><td>05</td><td>○</td><td></td><td>○</td></tr> <tr><td>06</td><td></td><td>○</td><td>○</td></tr> <tr><td>07</td><td>○</td><td>○</td><td>○</td></tr> <tr><td>08</td><td></td><td></td><td>○</td></tr> <tr><td>09</td><td>○</td><td></td><td>○</td></tr> <tr><td>0A</td><td>○</td><td>○</td><td>○</td></tr> <tr><td>0B</td><td>○</td><td>○</td><td>○</td></tr> <tr><td>0C</td><td></td><td></td><td>○</td></tr> <tr><td>0D</td><td>○</td><td></td><td>○</td></tr> <tr><td>0E</td><td></td><td>○</td><td>○</td></tr> <tr><td>0F</td><td>○</td><td>○</td><td>○</td></tr> <tr><td colspan="4">○ : IPDU error</td></tr> </tbody> </table>	A3-IPDU			Fan IPDU	1	2	3	01	○			02		○		03	○	○		04			○	05	○		○	06		○	○	07	○	○	○	08			○	09	○		○	0A	○	○	○	0B	○	○	○	0C			○	0D	○		○	0E		○	○	0F	○	○	○	○ : IPDU error				○	●	○	SIM	No. of IPDU error	I/F
A3-IPDU			Fan IPDU																																																																												
1	2	3																																																																													
01	○																																																																														
02		○																																																																													
03	○	○																																																																													
04			○																																																																												
05	○		○																																																																												
06		○	○																																																																												
07	○	○	○																																																																												
08			○																																																																												
09	○		○																																																																												
0A	○	○	○																																																																												
0B	○	○	○																																																																												
0C			○																																																																												
0D	○		○																																																																												
0E		○	○																																																																												
0F	○	○	○																																																																												
○ : IPDU error																																																																															
L30	L30	Detected indoor address	○	○	○	SIM	Indoor outside interlock	Indoor																																																																							
—	L31	—	—	—	—		Extended I/C error	I/F																																																																							
P01	—	—	●	○	○	ALT	Indoor fan motor error	Indoor																																																																							
P03	P03	—	○	●	○	ALT	Discharge temp. TD1 error	I/F																																																																							
P04	P04	01: Comp. 1 side 02: Comp. 2 side 03: Comp. 3 side	○	●	○	ALT	High-pressure SW system operation	IPDU																																																																							
P05	P05	00: Detected phase loss 01: Comp. 1 side 02: Comp. 2 side 03: Comp. 3 side	○	●	○	ALT	Phase loss error / interruption of power supply Inverter DC voltage (Vdc) error	I/F																																																																							
P07	P07	01: Comp. 1 side 02: Comp. 2 side 03: Comp. 3 side	○	●	○	ALT	Heat sink overheat error	IPDU, I/F																																																																							
P10	P10	Detected indoor address	●	○	○	ALT	Indoor overflow error	Indoor																																																																							
P12	—	—	●	○	○	ALT	Indoor fan motor error or duct setting miss	Indoor																																																																							
P13	P13	—	●	○	○	ALT	Outdoor liquid back detection error	I/F																																																																							
P15	P15	01: TS condition 02: TD condition	○	●	○	ALT	Gas leak detection	I/F																																																																							
P17	P17	—	○	●	○	ALT	Discharge temp. TD2 error	I/F																																																																							

Check code		Wireless remote control				Check code name	Judging device	
Wired remote control display	Outdoor 7-segment display	Sensor block display of receiving unit						
	Auxiliary code	Operation	Timer	Ready	Flash			
P18	P18	—	○	●	○	ALT	Discharge temp. TD3 error	I/F
P19	P19	Detected outdoor unit number	○	●	○	ALT	4-way valve inverse error	I/F
P20	P20	—	○	●	○	ALT	High-pressure protective operation	I/F
P22	P22	0*: IGBT circuit 1*: Location detection circuit error 3*: Motor lock-up error 4*: Motor current was detected. C*: Abnormal temperature was detected by the TH sensor. D*: TH sensor error E*: Inverter DC voltage error (outdoor unit fan)  Caution) Although letters 0 to F appear at locations indicated by "*", please ignore them.	○	●	○	ALT	Outdoor fan IPDU error	IPDU
P26	P26	01: Comp. 1 side 02: Comp. 2 side 03: Comp. 3 side	○	●	○	ALT	G-TR short protection error	IPDU
P29	P29	01: Comp. 1 side 02: Comp. 2 side 03: Comp. 3 side	○	●	○	ALT	Comp position detective circuit system error	IPDU
P31	P31	—	○	●	○	ALT	Other indoor unit error (Group follower unit error)	Indoor

**Error detected by TCC-LINK central control device**

Check code		Wireless remote control				Check code name	Judging device
Wired remote control display	Outdoor 7-segment display	Sensor block display of receiving unit					
	Auxiliary code	Operation	Timer	Ready	Flash		
C05	—	—	—	—	—	Sending error in TCC-LINK central control device	TCC-LINK
C06	—	—	—	—	—	Receiving error in TCC-LINK central control device	TCC-LINK
C12	—	—	—	—	—	Batch alarm of general-purpose equipment control interface	General-purpose equipment I/F
P30	—	Differs according to error contents of unit with occurrence of alarm	(L20 is displayed)			Group control branching unit error Duplicated central control addresses	TCC-LINK

TCC-LINK : TOSHIBA Carrier Communication Link.



# Warnings on refrigerant leakage

## Check of Concentration Limit

The room in which the air conditioner is to be installed requires a design that in the event of refrigerant gas leaking out, its concentration will not exceed a set limit.

The refrigerant R410A which is used in the air conditioner is safe, without the toxicity or combustibility of ammonia, and is not restricted by laws to be imposed which protect the ozone layer. However, since it contains more than air, it poses the risk of suffocation if its concentration should rise excessively. Suffocation from leakage of R410A is almost non-existent. With the recent increase in the number of high concentration buildings, however, the installation of multi air conditioner systems is on the increase because of the need for effective use of floor space, individual control, energy conservation by curtailing heat and carrying power etc.

Most importantly, the multi air conditioner system is able to replenish a large amount of refrigerant compared with conventional individual air conditioners. If a single unit of the multi conditioner system is to be installed in a small room, select a suitable model and installation procedure so that if the refrigerant accidentally leaks out, its concentration does not reach the limit (and in the event of an emergency, measures can be made before injury can occur).

In a room where the concentration may exceed the limit, create an opening with adjacent rooms, or install mechanical ventilation combined with a gas leak detection device. The concentration is as given below.

$$\frac{\text{Total amount of refrigerant (lbs (kg))}}{\text{Min. volume of the indoor unit installed room (ft}^3 \text{ (m}^3\text{))}} \leq \text{Concentration limit (lbs/ft}^3 \text{ (kg/m}^3\text{))}$$

The concentration limit of R410A which is used in multi air conditioners is 0.019 lbs/ft<sup>3</sup> (0.3 kg/m<sup>3</sup>).

### NOTE 1 :

If there are 2 or more refrigerating systems in a single refrigerating device, the amounts of refrigerant should be as charged in each independent device.

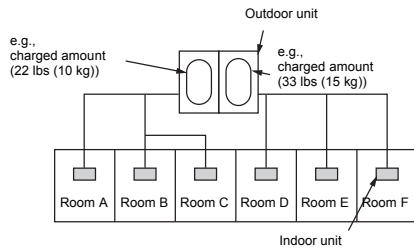

For the amount of charge in this example:

The possible amount of leaked refrigerant gas in rooms A, B and C is 22 lbs (10 kg).

The possible amount of leaked refrigerant gas in rooms D, E and F is 33 lbs (15 kg).

## Important

### NOTE 2 :

The standards for minimum room volume are as follows.

- (1) No partition (shaded portion)

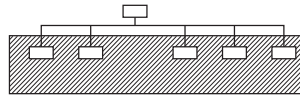

- (2) When there is an effective opening with the adjacent room for ventilation of leaking refrigerant gas (opening without a door, or an opening 0.15% or larger than the respective floor spaces at the top or bottom of the door).

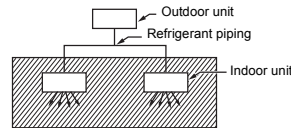

- (3) If an indoor unit is installed in each partitioned room and the refrigerant piping is interconnected, the smallest room of course becomes the object. But when a mechanical ventilation is installed interlocked with a gas leakage detector in the smallest room where the density limit is exceeded, the volume of the next smallest room becomes the object.

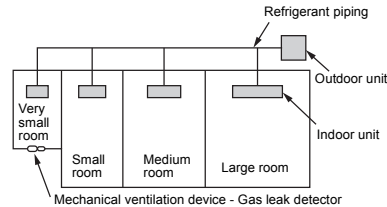

### NOTE 3 :

The minimum indoor floor area compared with the amount of refrigerant is roughly as follows:

(When the ceiling is 8.9 ft (2.7 m) high)

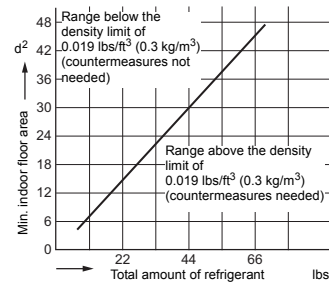

## Confirmation of Indoor Unit Setup

Prior to delivery to the customer, check the address and setup of the indoor unit, which has been installed in this time and fill the check sheet (Table below). Data of four units can be entered in this check sheet. Copy this sheet according to the No. of the indoor units. If the installed system is a group control system, use this sheet by entering each line system into each installation manual attached to the other indoor units.

### REQUIREMENT

This check sheet is required for maintenance after installation. Fill this sheet and then pass this Installation Manual to the customers.

### Indoor unit setup check sheet

Indoor unit			Indoor unit			Indoor unit			Indoor unit		
Room name			Room name			Room name			Room name		
Model			Model			Model			Model		
Check indoor unit address. (For check method, refer to Applicable controls in this manual.) * In case of a single system, it is unnecessary to enter the indoor address. (CODE No.: Line [12], Indoor [13], Group [14], Central control [03] )											
Line	Indoor	Group	Line	Indoor	Group	Line	Indoor	Group	Line	Indoor	Group
Central control address			Central control address			Central control address			Central control address		
Various setup			Various setup			Various setup			Various setup		
Have you changed lighting time of filter sign? If not, fill check mark [x] in [NO CHANGE], and fill check mark [x] in [ITEM] if changed, respectively. (For check method, refer to Applicable controls in this manual.)											
Filter sign lighting time (CODE No. [01])			Filter sign lighting time (CODE No. [01])			Filter sign lighting time (CODE No. [01])			Filter sign lighting time (CODE No. [01])		
<input type="checkbox"/> NO CHANGE <input type="checkbox"/> NONE [0000] <input type="checkbox"/> 150H [0001] <input type="checkbox"/> 2500H [0002] <input type="checkbox"/> 5000H [0003] <input type="checkbox"/> 10000H [0004]			<input type="checkbox"/> NO CHANGE <input type="checkbox"/> NONE [0000] <input type="checkbox"/> 150H [0001] <input type="checkbox"/> 2500H [0002] <input type="checkbox"/> 5000H [0003] <input type="checkbox"/> 10000H [0004]			<input type="checkbox"/> NO CHANGE <input type="checkbox"/> NONE [0000] <input type="checkbox"/> 150H [0001] <input type="checkbox"/> 2500H [0002] <input type="checkbox"/> 5000H [0003] <input type="checkbox"/> 10000H [0004]			<input type="checkbox"/> NO CHANGE <input type="checkbox"/> NONE [0000] <input type="checkbox"/> 150H [0001] <input type="checkbox"/> 2500H [0002] <input type="checkbox"/> 5000H [0003] <input type="checkbox"/> 10000H [0004]		
Have you changed detected temp. shift value? If not, fill check mark [x] in [NO CHANGE], and fill check mark [x] in [ITEM] if changed, respectively. (For check method, refer to Applicable control in this manual.)											
Detected temp. shift value setup (CODE No. [06])			Detected temp. shift value setup (CODE No. [06])			Detected temp. shift value setup (CODE No. [06])			Detected temp. shift value setup (CODE No. [06])		
<input type="checkbox"/> NO CHANGE <input type="checkbox"/> NO SHIFT [0000] <input type="checkbox"/> +1°C 1.8°F [0001] <input type="checkbox"/> +2°C 3.6°F [0002] <input type="checkbox"/> +3°C 5.4°F [0003] <input type="checkbox"/> +4°C 7.2°F [0004] <input type="checkbox"/> +5°C 9.0°F [0005] <input type="checkbox"/> +6°C 10.8°F [0006]			<input type="checkbox"/> NO CHANGE <input type="checkbox"/> NO SHIFT [0000] <input type="checkbox"/> +1°C 1.8°F [0001] <input type="checkbox"/> +2°C 3.6°F [0002] <input type="checkbox"/> +3°C 5.4°F [0003] <input type="checkbox"/> +4°C 7.2°F [0004] <input type="checkbox"/> +5°C 9.0°F [0005] <input type="checkbox"/> +6°C 10.8°F [0006]			<input type="checkbox"/> NO CHANGE <input type="checkbox"/> NO SHIFT [0000] <input type="checkbox"/> +1°C 1.8°F [0001] <input type="checkbox"/> +2°C 3.6°F [0002] <input type="checkbox"/> +3°C 5.4°F [0003] <input type="checkbox"/> +4°C 7.2°F [0004] <input type="checkbox"/> +5°C 9.0°F [0005] <input type="checkbox"/> +6°C 10.8°F [0006]			<input type="checkbox"/> NO CHANGE <input type="checkbox"/> NO SHIFT [0000] <input type="checkbox"/> +1°C 1.8°F [0001] <input type="checkbox"/> +2°C 3.6°F [0002] <input type="checkbox"/> +3°C 5.4°F [0003] <input type="checkbox"/> +4°C 7.2°F [0004] <input type="checkbox"/> +5°C 9.0°F [0005] <input type="checkbox"/> +6°C 10.8°F [0006]		
Incorporation of parts sold separately			Incorporation of parts sold separately			Incorporation of parts sold separately			Incorporation of parts sold separately		
Have you incorporated the following parts sold separately? If incorporated, fill check mark [x] in each [ITEM]. (When incorporating, the setup change is necessary in some cases. For setup change method, refer to Installation Manual attached to each part sold separately.)											
<input type="checkbox"/> Others ( ) <input type="checkbox"/> Others ( )			<input type="checkbox"/> Others ( ) <input type="checkbox"/> Others ( )			<input type="checkbox"/> Others ( ) <input type="checkbox"/> Others ( )			<input type="checkbox"/> Others ( ) <input type="checkbox"/> Others ( )		