

# Installation, Start-up, and Operating Instructions

## TABLE OF CONTENTS

	Page
SAFETY CONSIDERATIONS .....	1
INTRODUCTION .....	2
INSTALLATION CONSIDERATIONS .....	2
COMPONENT DESCRIPTIONS .....	3
UNIT INSTALLATION .....	3
WALL CONTROL .....	5
ELECTRICAL CONNECTIONS .....	6
ACCESSORIES .....	7
BALANCING ERV .....	7
CONTROL BOARD OPERATION .....	9
CARE AND MAINTENANCE .....	9
TROUBLESHOOTING .....	10
OPERATING THE ERV WITH INFINITY CONTROL ....	11
WIRING DIAGRAM .....	12

**NOTE:** Read the entire instruction manual before starting the installation.

This symbol → indicates a change since the last issue.

## SAFETY CONSIDERATIONS

Installation and servicing of this equipment can be hazardous due to mechanical and electrical components. Only trained and qualified personnel should install, repair, or service this equipment.

Untrained personnel can perform basic maintenance functions such as cleaning and replacing air filters. All other operations must be performed by trained service personnel. When working on this equipment, observe precautions in the literature, on tags, and on labels attached to or shipped with the unit and other safety precautions that may apply.

Follow all safety codes. Installation must be in compliance with local and national building codes. Wear safety glasses, protective clothing, and work gloves. Have fire extinguisher available. Read these instructions thoroughly and follow all warnings or cautions included in literature and attached to the unit.

Recognize safety information. This is the safety-alert symbol . When you see this symbol on the unit and in instructions or manuals, be alert to the potential for personal injury. Understand these signal words; DANGER, WARNING, and CAUTION. These words are used with the safety-alert symbol. DANGER identifies the most serious hazards which **will** result in severe personal injury or death. WARNING signifies hazards which **could** result in personal injury or death. CAUTION is used to identify unsafe practices which **may** result in minor personal injury or product and property damage. NOTE is used to highlight suggestions which **will** result in enhanced installation, reliability, or operation.

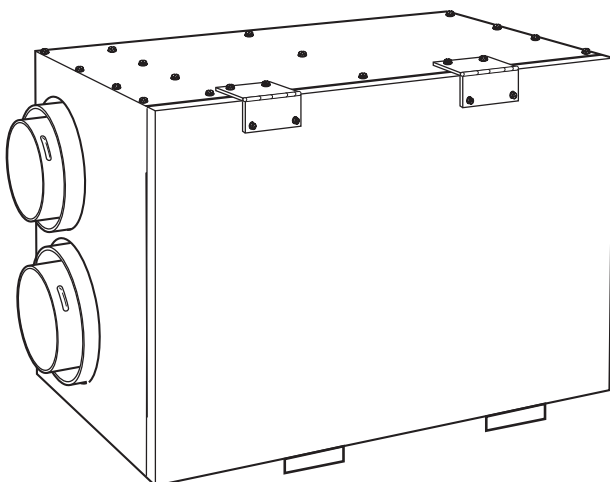

**Fig. 1 - ERVCLHU Energy Recovery Ventilator**

A00092

## INTRODUCTION

The ERVCCLHU Energy Recovery Ventilator is used to exchange indoor stale air with outside fresh air. The unit is equipped with a special energy recovery core which transfers both sensible and latent heat between the fresh incoming air. The cross-flow design core allows entering and leaving air streams to transfer heat energy without mixing (see Fig. 13).

The ERVCCLHU is available in 2 sizes with airflow ranges of 64-152 CFM, and 117-214 CFM. The design of this unit is horizontal. Special attention should be given to duct application, balancing the ERV, and locating unit for easy access and routine maintenance.

## INSTALLATION CONSIDERATIONS

### Step 1—Inspect Equipment

Move carton to final installation location. Remove ERVCCLHU from carton taking care not to damage unit. Remove all packaging and inspect unit for damage. Remove parts bag from inside unit. File claim with shipping company if shipment is damaged or incomplete. Check to make sure ERV unit matches Fig. 2.

### Step 2—Select Location

The ERV **should be located in a conditioned space** and in close proximity to a fused power source. It should be easily accessible for routine maintenance.

If ERV is installed independent of a forced-air system, unit should be located near the center of the air distribution system. If ERV is installed in conjunction with a forced-air system, unit should be located next to (or close to) the indoor equipment.

ERV

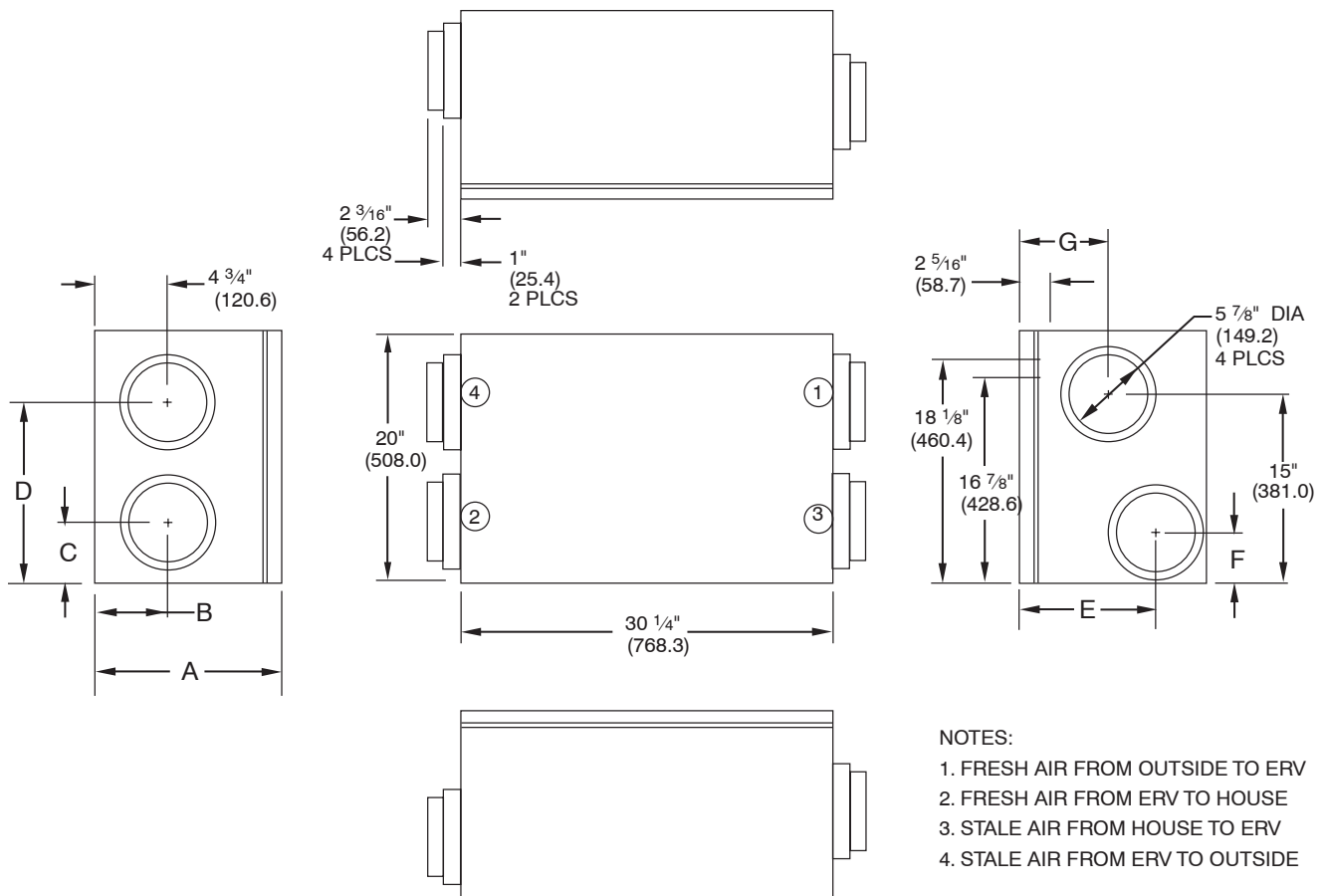

A00093

MODEL NO.	A		B		C		D		E		F		G	
	in.	mm	in.	mm	in.	mm	in.	mm	in.	mm	in.	mm	in.	mm
ERVCCLHU1150	15-1/8	384.2	4-1/16	104	5-5/8	143.3	14-1/2	368.9	10-3/8	288.9	4-3/8	111.3	7-3/4	196.9
ERVCCLHU1200	19	483	5-13/16	147.7	5-1/16	128.6	14-1/2	368.9	11-3/16	283.9	4-3/8	111.3	10-1/16	255.6

Fig. 2 - ERVCCLHU Dimensional Drawing

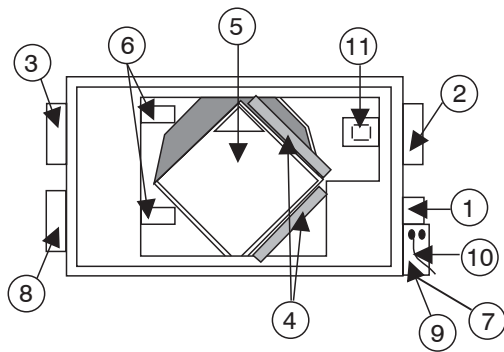

A00113

**Fig. 3 - ERVCLHU Cross-Flow**

## COMPONENT DESCRIPTION

The following listed items are components of ERVCLHU (see Fig. 3).

1. Stale air return from building connected to return-air duct system.
2. Fresh-air intake connected to outdoor air inlet hood.
3. Exhaust-air connected to outdoor air exhaust hood.
4. Mechanical filters trap dust contained in the air.
5. Energy recovery core is a cross-flow type. It transfers sensible and latent energy between the 2 air streams.
6. Blowers bring in fresh-air from outside and exhaust stale-air to outside.
7. Electronic control circuit ensures proper unit operation.
8. Fresh-air supply connected to return-air duct.
9. Terminal connector block for wiring wall and timer controls.
10. Electrical cord connects to standard 115v outlet.
11. Damper motor.

## UNIT INSTALLATION

### ⚠ CAUTION

#### UNIT DAMAGE HAZARD

Failure to follow this caution may result in equipment damage or improper operation.

Do not install ERV in a corrosive or contaminated atmosphere.

#### Step 1—Mount Unit

The ERV can be suspended from floor joists using chains and 4 springs. Attach metal hanging bracket to all 4 sides of cabinet (see Fig. 4). The unit may be installed on a shelf if an isolation pad is provided to dampen vibration. Unit should always be installed as level as possible.

#### Step 2—Independent System Application

In the absence of a forced-air system and a typical duct system layout, the ERV can be applied as an independent or stand alone unit. To ensure comfort, this type of application involves running both fresh-air and return-air registers (or stale-air pickup registers) throughout the home.

Fresh-air registers are normally located in bedrooms, dining rooms, living rooms, and basements. It is recommended that registers be

placed 6 to 12 in. from the ceiling on an interior wall and airflow directed toward the ceiling. If registers are floor installed, airflow should be directed toward the wall.

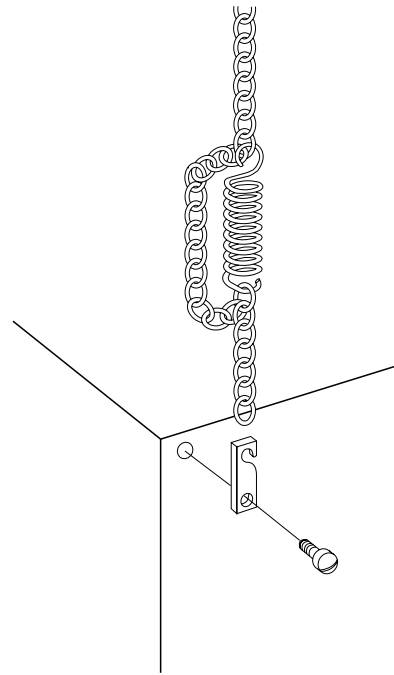

A92269

**Fig. 4 - Chain Spring Installation**

### ⚠ WARNING

#### CARBON MONOXIDE POISONING HAZARD

Failure to follow this warning could result in personal injury or death.

Do not install return-air registers (or stale-air pickup registers) in same room as gas furnace or water heater.

Return-air (or stale-air pickup registers) are normally located to draw from kitchens, bathrooms, basements, or other rooms where stale-air can exist.

Proper size and type of registers must be used to minimize pressure drop. The velocity of airflow through register should not be above 400 ft/minute.

Maximum length of duct for the system should be designed according to the highest speed of the unit. Refer to specifications listed in unit Product Data Digest for ventilation capacities.

#### Step 3—Forced-Air Application

Most ERV applications will be installed in conjunction with new or existing forced-air systems. To operate properly, the fresh-air supply and stale-air return from ERV connect directly to return-air duct system. This is how the ERV distributes fresh air and removes stale air from inside of building (see Fig. 5). For these installations, furnace or fan coil blower must be interlocked and operate continuously whenever ERV is energized.

**NOTE:** The fresh air from ERV is introduced into return-air duct at a point no less than 6 ft upstream of furnace or fan coil. This connection should be direct (see Fig. 5). This is to allow incoming fresh-air to mix before entering indoor equipment.

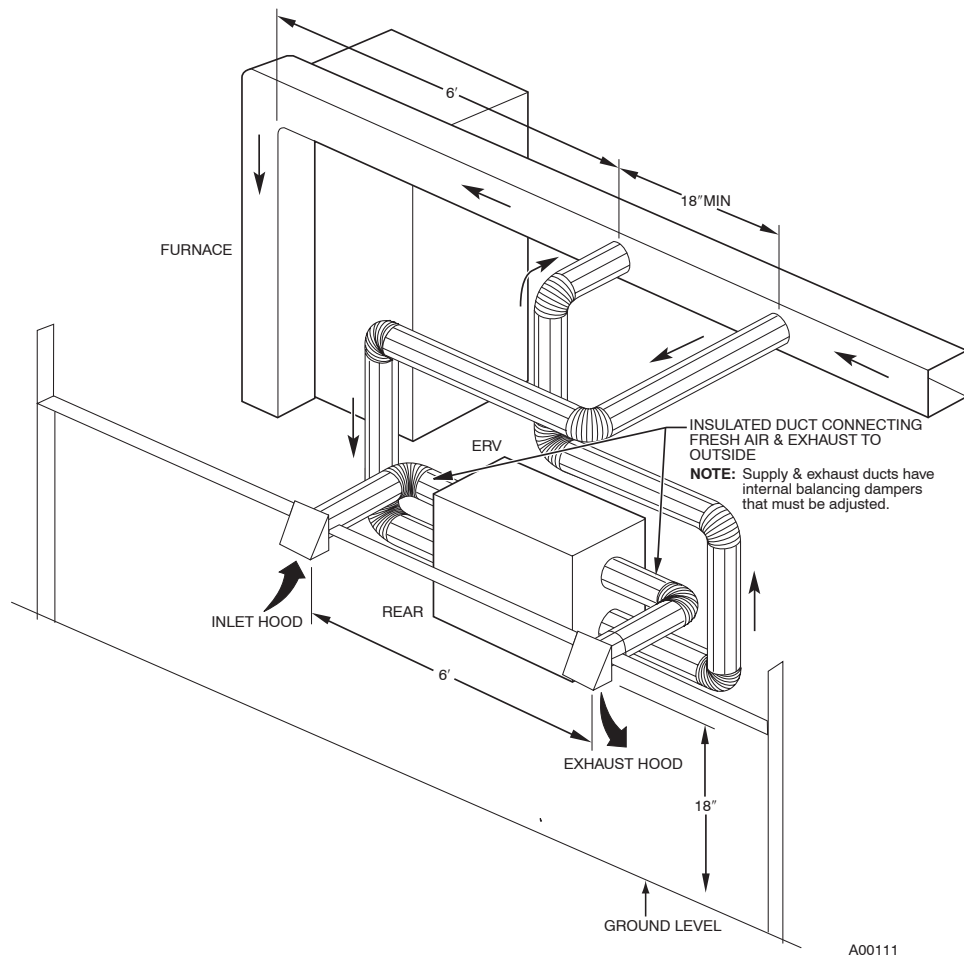

Fig. 5 - Exhaust Ventilation

A00111

Step 4— Connect Ducts to ERV

**⚠ CAUTION**

**PROPERTY DAMAGE HAZARD**

Failure to follow this caution may result in minor property damage from sweating duct or loss of unit efficiency and capacity. ERV should be installed in a conditioned space with insulated flex duct for supply and exhaust air to the outdoor ambient.

**Insulated flexible duct is required on both fresh-air inlet and exhaust-air outlet ducts connecting to exterior wall.** When using insulated flexible duct, the vapor barrier of the flexible ducts must be taped very tightly to prevent condensation problems. To reduce pressure drop, stretch the flex duct and support it in a proper manner to avoid reduced airflow.

When connecting the ERV to a return-air duct system, insulated flexible duct can be used. However, when metal or rigid ducts are applied use approximately 18 in. of flexible duct at ERV ports for fresh-air supply and stale-air return. When using metal duct from fresh-air supply to system duct work, the metal duct should be insulated (see Fig. 6). This can act as a silencer when connecting ducts to return-air duct system. This should eliminate transmission of noise or vibration from unit to main duct system. In addition, there are four 30 in. duct ties provided to help fasten flexible duct to port on ERV.

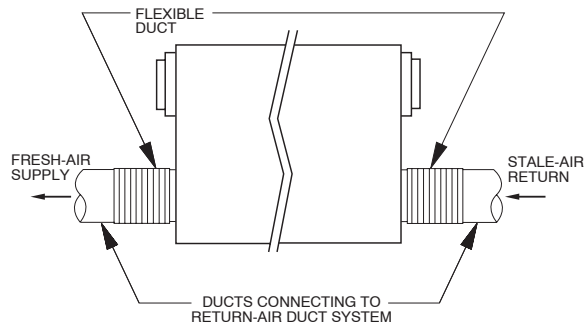

Fig. 6 - Flexible Duct Fit-Up

A98382

Step 5—Locate and Install Exterior Hoods

**IMPORTANT:** To prevent condensation problems, insulated flexible ducts are required on both fresh-air inlet and exhaust-air outlet ducts connecting between ERV and exterior wall.

Fresh-air intake and stale-air exhaust must be separated by at least 6 ft. Fresh-air intake must be positioned at least 10 ft from nearest dryer vent, furnace exhaust, driveway, gas meter, or oil fill pipe. Fresh-air intake must be positioned as far as possible from garbage containers and potential chemical fumes. When possible, it is advised to locate the intake and exhaust hoods on same side of house or building. The intake and exhaust hoods should never be located on interior corners or in dead air pockets (see Fig. 5). Both intake and

exhaust hoods must be 18 in. from ground and at least 12 in. above anticipated snow level.

After selecting proper hood locations, make appropriate size hole through exterior wall, pass flexible duct through hole and insert hood tube into duct. Tape duct vapor barrier tightly around hood tube and insert assembly back into wall and fasten securely.

**Step 6—Condensate Drain**

To connect condensate drain, proceed as follows:

1. Insert sleeved grommets into bottom of unit using the gasket washer and nut (see Fig. 7).
2. Cut two sections of plastic tubing, about 12” long and attach them to each drain.
3. Join the two short sections of plastic tubing to the “T” connector and the main tube as shown.
4. Make a loop in the tubing below the “T” connector to create a trap to prevent sewer gases from entering the ventilation system (see Fig. 7).
5. Connect unit drain to building’s main drain. Provide slight slope from unit for run-off.

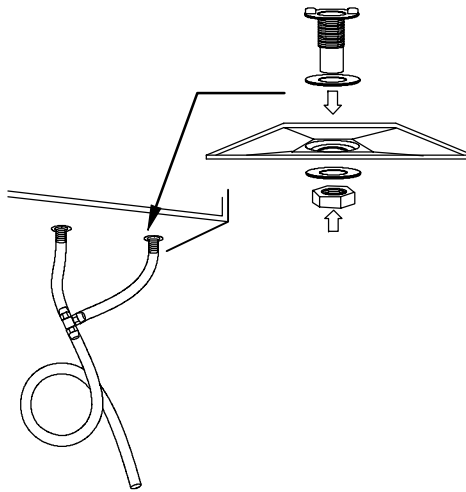

A99268

**Fig. 7 - Condensate Drain With Loop Trap**

**WALL CONTROL**

**Location**

The ERV wall control is unique to this unit. The ERV will not operate without it. This control senses humidity not temperature. It must be located in an area where it will continually monitor fresh air circulating within the home. Install ERV wall control as close as possible to main system thermostat and follow same guidelines as installing a thermostat (locate approximately 5 ft above floor, mount on an inside partitioning wall, etc.).

**Wiring**

Remove top cover assembly from wall control and pass thermostat wire through hole located on back of control before attaching to wall. Connect Y, R, G, and B (yellow, red, green, and black) between wall control and ERV connector following color code (see Fig. 8 and 9). Replace top cover assembly. In Fig 9, item A shows a correctly inserted wire, item B shows an incorrectly inserted wire.

**NOTE:** ERV wall control and circuit board operate on 12vdc.

**Operation**

The ERV wall control has 4 basic modes of operation, OFF, LOW, HIGH, and INTERMITTENT. Be sure that all modes of operation are fully functional. See Table 1 indicating standard control operation.

1. With switch OFF, ERV is inoperative and the LED is out.
2. With switch on LOW, ERV continuously exchanges air with outside. If control is satisfied, blower will run in low speed, otherwise, blower will run on HIGH speed. The LED is illuminated all the time.
3. INTERMITTENT-If relative humidity level inside of building is higher than setpoint, then no air exchange will occur and ERV shuts off. If relative humidity level inside building is lower than setpoint, then air exchange occurs at high speed, and shuts down ERV when humidity level reaches setpoint. This mode is ideal for maintaining proper humidity level when continuous mode cannot. To ensure highest degree of humidity control in cooling season, intermittent mode should not be used.

**Humidity Selection**

The humidity selector is a built-in control designed to properly control the level of humidity in the house during the summer months. This acts like a limit switch. See Table 2 to select maximum humidity level. If the house becomes too dry in winter months, put wall control in INTERMITTENT mode and turn down humidity selector to provide ventilation less frequently.

**OneTouch Control**

The OneTouch control may be used as the primary wall control for the ERV. This control will step through the modes of operation with consecutive presses of the button. The LED indicates which mode is currently selected; Off, Intermittent, Low, or High. There is no humidity sensor on the OneTouch, and it will not provide direct humidity control.

**Latent Control**

**NOTE:** To ensure highest degree of humidity control in cooling season, the INTERMITTENT mode should be used. See Table 1 and reference LOW and INTERMITTENT control operation listed above.

**Table 1—Basic Control**

MODE	OPERATION	DAMPER POSITION	FAN SPEED
Off	Off	Closed to outside	Off
Low	Air exchange with outside	Open to outside	Low
Intermittent	Air exchange with outside	Open to outside	Low
High	Air exchange with outside	Open to outside	High

ERV

Table 2—Recommended Humidity Levels

OUTSIDE TEMPERATURE		DOUBLE-PANE WINDOWS	TRIPLE-PANE WINDOWS
50° F	10° C	55 percent	65 percent
32° F	0° C	45 percent	55 percent
14° F	-10° C	35 percent	45 percent
-4° F	-20° C	30 percent	45 percent
-22° F	-30° C	25 percent	35 percent

ERV

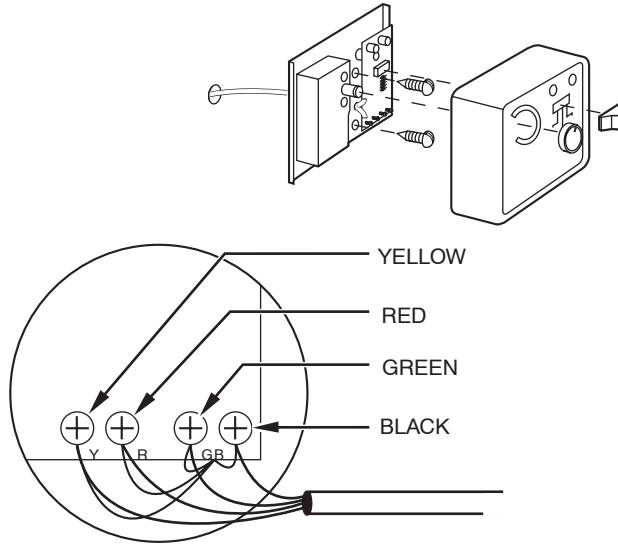

Fig. 8 - Typical Wall Control

A00112

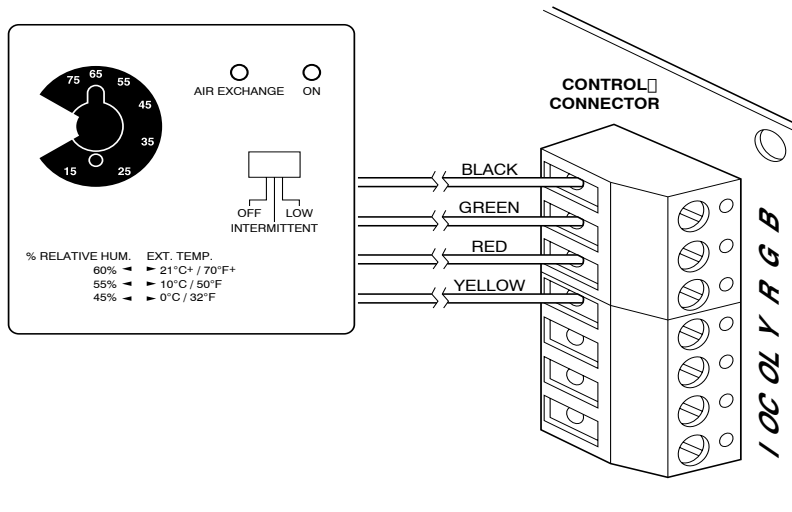

Fig. 9 - Control Connector

A98384

**ELECTRICAL CONNECTIONS**

**⚠ WARNING**

**ELECTRICAL SHOCK HAZARD**

Failure to follow this warning could result in personal injury or death.

Before installing or servicing system, always turn off main power to system. There may be more than 1 disconnect switch.

**115vac Wiring**

The ERV operates on 115vac. It comes with a power cord attached to unit and ready to plug into a fused outlet. Unit must be grounded for proper operation.

All electrical connections must comply with National and Local Electrical Codes, or other ordinances that might apply.

**12vdc Wiring**

The ERV circuit board, wall control, and accessories operate on 12vdc. See Wall Control section, item Wiring and Fig. 8 and 9 for more information.

The ERV comes with an integrated interlock. The interlock can be wired to the system blower to ensure that the blower is running when

there is a call for ventilation. See the wiring diagram for proper wiring of the interlock circuit.

## ACCESSORIES

### 20 Minute Timer

A push button timer can be used to override the wall control and put the ERV into high speed for 20 minutes. Connect switches in parallel and connect leads to ERV terminals I, OC, and OL (see Fig. 11). Push button locations are ideal in special activity areas, such as bathrooms or kitchens, where high-speed exhaust operation is needed for a short period of time.

**NOTE:** The 20 minute timer will not function properly unless ERV wall control is applied and working correctly. Timing function is internal to electronic circuit board, it is activated by a momentary contact between OC and OL. The I connection is to illuminate the push button. The maximum number of push button timers that can be applied is 5.

### 60 Minute Adjustable Timer

A 60 minute adjustable timer can also be used to override wall control and put ERV into high-speed operation for a select amount of time. Connect timer in parallel with push button timers, or to ERV terminals OC and OL (see Fig. 11).

The 60 minute timer will provide a minimum of 10 minutes, and a maximum of 60 minutes of ventilation at high speed.

## BALANCING ERV

Balancing intake and exhaust airflow is very important for proper system operation and optimum performance when applying an ERV. Unit balancing prevents positive and/or negative pressure within the home. Balancing the ERV is done by applying temporary flow collars and adjusting the balancing dampers to the fresh air intake and stale air exhaust ducts (see Fig. 11).

Airflow is temporarily determined by connecting a magnehelic gage to the temporary flow collars (see Fig. 12). Both flow collars and magnehelic gage are included in the accessory start-up balancing kit.

If supply-air from outside is greater than exhaust-air from the house, an imbalance can result over-pressurizing the home. If exhaust-air is greater than supply-air, combustion appliances may backdraft, bringing exhaust fumes into the house. A balanced condition will ensure optimum performance, provide satisfied customers, and avoid expensive callbacks.

Before proceeding with balancing, all windows, doors, and fireplace flues should be tightly closed. No exhaust systems such as

range top exhausts, dryer exhaust, fume hoods, bath or roof fans should be in operation. The forced-air furnace (if used for circulation) should be operating in continuous fan mode for normal operating speed.

### Balancing Dampers

Balancing dampers (sometimes called butterfly dampers) are located in fresh-air intake and stale-air exhaust of the ERV. (See Fig. 11.) Some field modification may be required to ensure proper installation of balancing dampers while located in flexible duct. Insulating over these dampers is strongly recommended after balancing is complete to prevent condensation problems.

### Flow Collar

Flow Collars are temporary and should be installed as close to the ERV as possible, and in the straightest sections of the duct to ensure accuracy (see Fig. 11). If only one flow collar is available, install collar in the fresh-air duct and record airflow. If two flow collars are available, it will be much easier to read airflow and properly adjust dampers to balance unit.

With wall control at maximum speed (high-speed operation) and furnace or fan coil on continuous fan, connect hoses to flow collar to a magnehelic gage (see Fig. 12). When balancing the ERV make sure all doors and windows are closed. All exhaust fans, cooking ranges, and dryers are turned off and the furnace or fan coil blower is on. The gate must be leveled and zeroed before use to read accurately. If needle falls below zero, reverse hose connections.

Measure exhaust air first. It is typically the lowest pressure due to the nature of the system and duct work. Next measure fresh air. If fresh air reading is higher than exhaust reading, adjust damper until reading is same. If reading is lower, return to exhaust damper and adjust to obtain same reading. The label on flow collar can be used to convert static pressure to airflow.

Once ERV is balanced and dampers are adjusted to equalize airflow, use tape or drive screw to prevent damper blades from moving. Remove flow collars and secure ducts. This procedure should be repeated to ensure unit is balanced properly.

**NOTE:** The flow collar directional arrow (on flow collar) must be oriented in the airflow direction of the unit.

**NOTE:** Some field modification may be required to ensure proper temporary installation of flow collar during balancing when insulated flexible duct is used.

**NOTE:** For airflow pattern see Fig. 13.

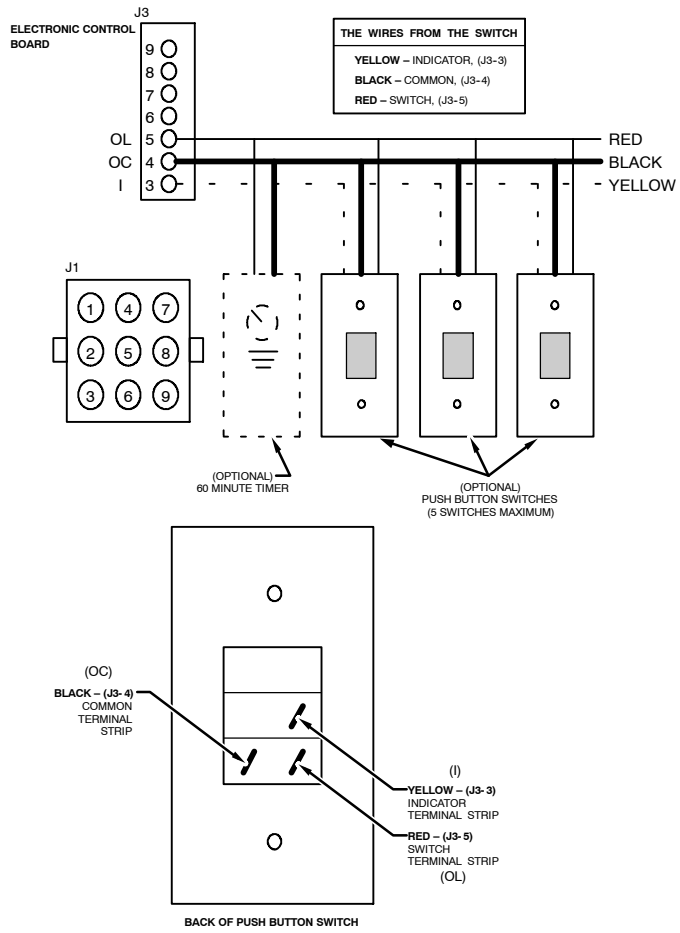

Fig. 10 - Push Button Timer Wiring Layout

A98386

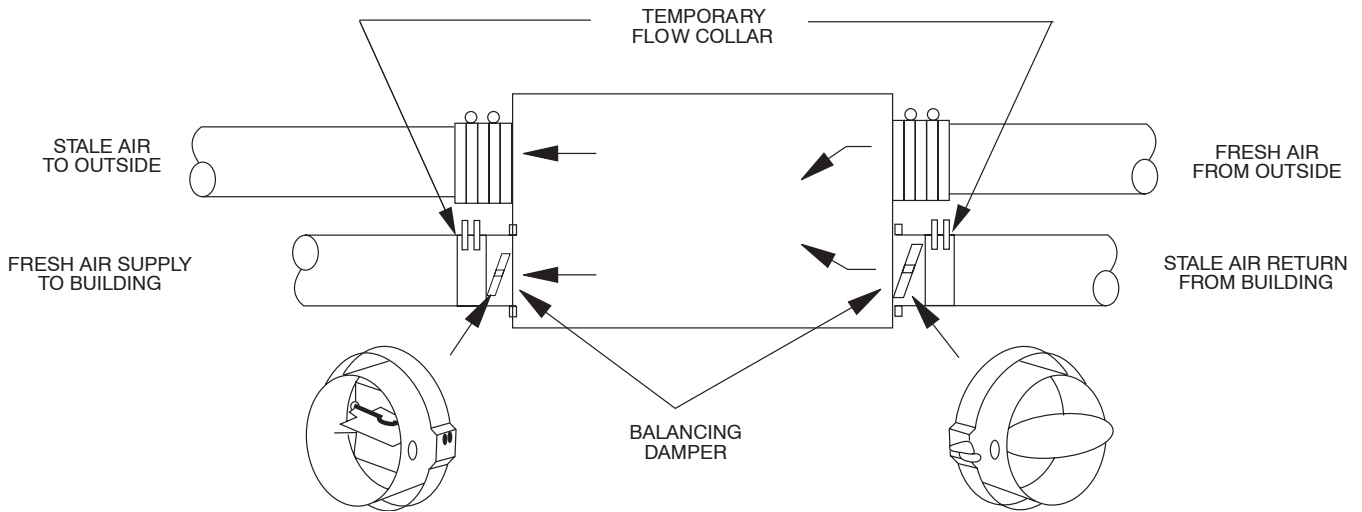

Fig. 11 - Balancing ERVCLHU

A05043



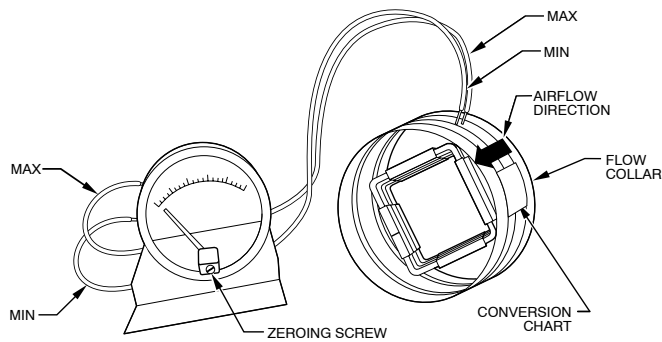

Fig. 12 - Magnehelic Gage

A98400

## CONTROL BOARD OPERATION

### Board Function

To ensure proper operation of ERV, configuration jumpers are located on electronic control board and must match configuration setup shown in Fig. 14 under Jumper Table. Jumpers are factory set and do not require any changes unless control board is replaced. If control board is replaced, or unusual start-up operation is encountered, check jumpers to make sure they are located properly.

### Outdoor Ambient Below 23° F (-5° C)

The ERV continually monitors outside air temperature. If outside air is at or below 23° F (-5° C), ERV will cycle between air exchange and defrost.

The ERV measure the incoming air temperature and will cycle unit in and out of defrost, depending on outdoor ambient. The intake damper will close and circulate indoor air through the core for 6 to 10 minutes. This time depends on jumper location. Refer to Table 7 for defrost cycle.

### OFF and INTERMITTENT/OFF Mode

When ERV is Off, K1 relay is open (see Fig. 14).

### High-Speed Air Exchange

When high-speed air exchange occurs, K1 relay closes and K2 (12vdc relay) is energized. This opens low-speed contacts, and closes high-speed contacts. Then, 115vac is applied between orange and gray wires on Molex® plug (pins 1 and 6) and blower motor runs in high-speed operation. Also, 115vac is applied across pins 5 and 7, this energizes interlock relay (see Fig. 14).

### Low-Speed Air Exchange

When low-speed air exchange occurs, K1 relay closes and K2 (12vdc relay) is de-energized. This keeps low-speed contacts closed and high-speed contacts open. Then, 115vac is applied between red and gray wires on Molex plug (pins 1 and 4) and blower motor runs in low-speed operation. Also, 115vac is applied across pins 5 and 7, energizing interlock relay (see Fig. 14).

## ⚠ WARNING

### ELECTRICAL SHOCK HAZARD

Failure to follow this warning could result in personal injury or death.

Before installing or servicing system, always turn off main power to system. There may be more than 1 disconnect switch.

## ⚠ CAUTION

### CUT HAZARD

Failure to follow this caution may result in personal injury.

Sheet metal parts may have sharp edges or burrs. Use care and wear appropriate protective clothing and gloves when handling parts.

## CARE AND MAINTENANCE

### Door

ERV door can be removed by unlatching brief case style latches, then lifting door up and sliding it sideways (see Fig. 15). Door must be in place and secured shut for proper operation.

### Filter

Filters in ERV are washable and should be cleaned every 3 months. Use a vacuum cleaner to remove heaviest portion of accumulated dust, then wash in lukewarm water. Allow filter to completely dry before reinstalling. A dirty air filter will cause excessive strain on blower motor. Never operate unit without a filter (see Fig. 15).

In addition, regularly check and clean screens on exterior intake and exhaust hoods when necessary.

## ⚠ CAUTION

### UNIT COMPONENT DAMAGE HAZARD

Failure to follow this caution may result in unit component damage.

DO NOT clean filters in a dishwasher and DO NOT dry them with a heating appliance or permanent damage will result.

### Blower Motor and Wheel

ERV blower motors are factory lubricated for life. Lubricating bearings is not recommended. However, inspect and clean any accumulated dirt and grease from blower motor and wheel annually.

### Cleaning the Core

ERV is equipped with a special energy recovery core which is made out of paper and allows transfer of sensible and latent energy. The core should always be only vacuumed every 3 months to remove dust and dirt that could prevent transfer of energy (see Fig. 17).

**NOTE:** The core should only be serviced when outdoor temperature is between 60°F and 75°F and it is dry.

ERV

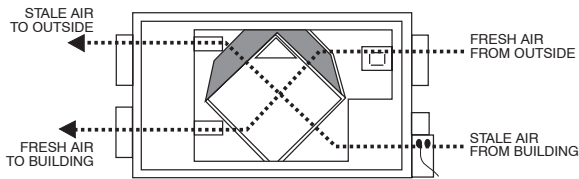

Fig. 13 - ERV Airflow During Air Exchange

## CAUTION

### UNIT COMPONENT DAMAGE HAZARD

Failure to follow this caution may result in equipment damage or improper operation.

DO NOT use water to clean core or damage will result. In addition, before servicing or removing the core inspect the edges to see if they appear soft (or slightly expanded). This can be normal and due to moisture in the air. DO NOT handle or service core until it is dry or air passages can become damaged and/or closed.

ERV

## TROUBLESHOOTING

## WARNING

### ELECTRICAL SHOCK HAZARD

Failure to follow this warning could result in personal injury or death.

Before installing or servicing system, always turn off main power to system. There may be more than 1 disconnect switch.

## CAUTION

### CUT HAZARD

Failure to follow this caution may result in personal injury.

Sheet metal parts may have sharp edges or burrs. Use care and wear appropriate protective clothing and gloves when handling parts.

**NOTE:** Reference Table 3 Troubleshooting Chart

This can be a quick guide in resolving unit problems. It is also recommended to review and understand Wall Control Board Operation and Care and Maintenance sections before continuing. There are 3 main parts to focus on when troubleshooting ERV unit:

1. Wall Control
2. Electronic control board
3. Blower motor

### Step 1—Wall Control

Use Table 1 to determine if wall control is operating correctly. Use Fig. 9 to check control wire connections.

**NOTE:** The electronic control board and wall control operate on 12vdc.

### Step 2—Control Board

Electronic control board must have wall control attached before unit will function properly. Also, configuration jumpers located on control board must match configuration setup show in Fig. 14 under Jumper Table. In addition, outside air thermistor must be connected to control board for it to operate properly. See Table 4, Temperature - vs - Ohm Chart, for valid temperature range.

### Step 3—Blower Motor

The ERV blower motor operates on 115vac, with 2-speed operation.

The easiest way to check blower speed operation is to use the wall control and initiate a low-speed blower and high-speed blower operation using intermittent mode (see Table 1).

**NOTE:** If, after using the following test, you still hear relays clicking upon charge, carefully check wiring, blower capacitor, and blowers.

Alternate procedure to check blower speed:

#### Blower Speed Test

##### HIGH SPEED

1. Disconnect ERV from 115vac.
2. Unplug wall control wires at control module terminal block inside ERV.
3. Plug ERV back to 115vac.
4. Attach a wire across J3-8 and J3-9 (B and G) on control module terminal block.
5. Push in door switch, this will initiate a high-speed exchange.

##### LOW SPEED

1. Unplug ERV from 115vac.
2. Disconnect wall control wires at control module terminal block inside ERV.
3. Plug ERV back to 115vac.
4. Connect a 3.0 K ohm resistor between B and G on control module terminal block.
5. Push in door switch, this will initiate a low-speed exchange.

### Step 4—Blower Speed Selection

Three-speed blowers are factory connected to electronic control board on HIGH- and LOW-speed taps of blowers. Installer can easily change low-speed tap to medium-speed tap so electronic control will select between high and medium speed. Connections can be changed at motor location (see Table 5 and 6).

To change low speed to medium speed, proceed as follows:

1. Unplug unit from 115vac.
2. Remove filters and core from ERV.
3. Locate and remove wing nut on left side of unit.
4. Slide blower assembly to the right until wire connections are visible.
5. Locate red wire and blue wire coming from blower assembly.
6. Unplug red wire from quick connect.
7. Unplug protecting cap quick connection from blue wire and put on red wire coming from blower. The cap is a safety insulator.
8. Connect red wire of main harness to blue wire.
9. Replace wires, blower assembly, filters, and core.

### Step 5—Outdoor Air Thermistor

When unit is not responding to wall control, check outdoor air thermistor.

1. Remove thermistor wire from control board.

2. Take ohm reading across thermistor.
3. Refer to Table 4 for temperature/ohm relationship.

## OPERATING THE ERV WITH THE INFINITY CONTROL

The ERV may be controlled using the Infinity system control. The ERV may be connected using either a NIM or a 4-Zone Damper Module. See the appropriate instructions if using the NIM or 4-Zone Damper Module for connection instructions.

Blower interlock relay is not needed for use with the Infinity system control. The Infinity system control will simultaneously control the ERV and the indoor blower.

Push Button Timers may be used and are connected to the ERV as shown in Fig. 11. However, the Infinity system should be set to continuous fan to ensure that the fresh air is circulated in the home.

In a Zoned System, at least one zone should be set to continuous fan.

The ventilator has four settings in heating mode and three settings in cooling mode.

### Heating:

**AUTO** - the ventilator selects the speed based on indoor humidity and outdoor temp. It may cycle on/off every 30 minutes depending on humidity and outside temp.

**LOW** - low speed all of the time.

**HIGH** - high speed all of the time.

**DEHUM** - will only turn on if humidity is 3% over the set point. The speed is determined by indoor humidity and outdoor temp.

### Cooling:

**AUTO** - the ventilator selects the speed based on indoor humidity and outdoor temp. It may cycle on/off every 30 minutes depending on humidity and outside temp.

**LOW** - low speed all of the time.

**HIGH** - high speed all of the time.

If the fan speed is set to Auto and the ventilator wants to run, the fan speed will run at High continuous speed. Otherwise, the fan will stay at the chosen continuous fan speed.

**ERV**

**Table 3—Troubleshooting Chart**

SYMPTOMS	CAUSES	SOLUTIONS
<b>Air too humid</b>	Continuous exchange mode used in small houses	Use Intermittent Mode Check humidity level settings
<b>Unit not responding to wall control</b>	Defrost condition is in effect Outdoor temperature is below 23°F	Unit will operate when not in defrost mode. Defrost cycle is based on outdoor ambient (see Table 10)
	Broken control wire	Test wall control Check connections Check thermistor
<b>Unit stops momentarily</b>	Electrical supply interrupted	Check units circuit breaker
<b>Air from distribution register too cold</b>	Improper calibration of air flow	Check calibration of flow rates
<b>Unit makes annoying noise</b>	Ventilation wheel out of adjustment	Remove the motor and screw wheel on properly
<b>Noise level too high at distribution registers when in high speed</b>	Air duct system too short	Install a duct silencer

**Table 4—Defrost Cycle**

Outside Temperature		ERV Defrost Cycles	
Celsius (°C)	Fahrenheit (°F)	Defrosting (min.)	Operation time (min.) between each defrost cycle
-5 to -27	23 to -17	9	23
-27 and less	-17 and less	10	22

**Table 5—System Wiring Colors and Connections**

CONTROL MODULE		WALL CONTROL WIRE	WALL CONTROL	
Terminal Block No.	Terminal Block Identification	Color	Terminal No.	Terminal Identification
<b>J3-9</b>	B	Black	J1-4	B
<b>J3-8</b>	G	Green	J1-3	G
<b>J3-7</b>	R	Red	J1-2	R
<b>J3-6</b>	Y	Yellow	J1-4	Y

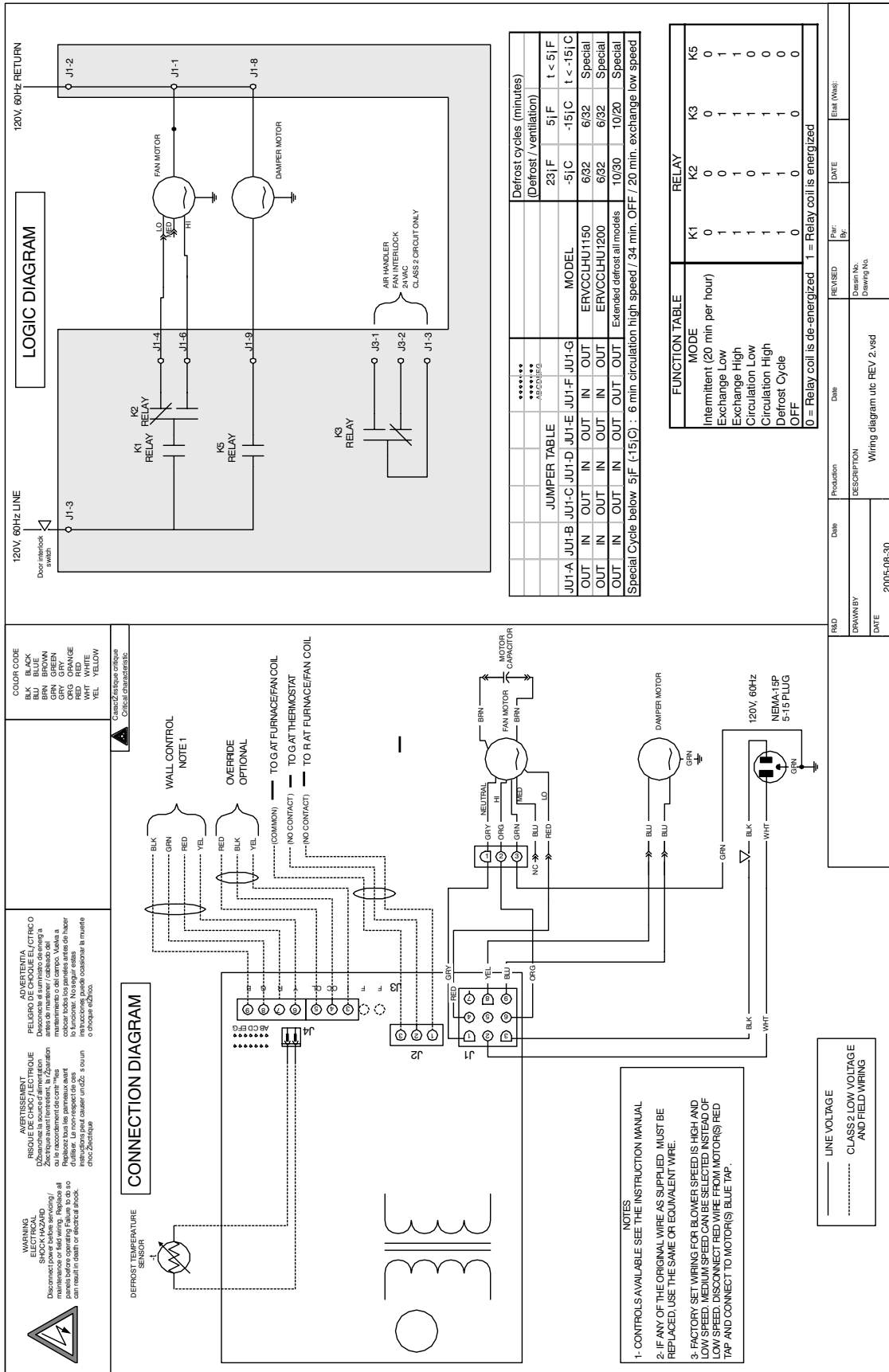

**Fig. 14 - ERV Wiring Diagram**

A06117



**Table 6—Temperature/Ohm Relationship**

Temp. (degrees F)	Ohms
30	34,480
32	32,680
34	30,760
36	29,220
38	27,470
40	26,020
42	24,680
44	23,320
46	22,070
48	20,910
50	19,830
52	18,820
54	17,870
56	16,920
58	16,160
60	15,260
62	14,530
64	13,790
66	13,090
68	12,480
70	11,860
72	11,270
74	10,750
76	10,250
78	9,750
80	9,300
82	8,840
84	8,432
86	8,042
88	7,668
90	7,310
92	6,993
94	6,661
96	6,368
98	6,085
100	5,811
102	5,571
104	5,313
106	5,088
108	4,869
110	4,660
112	4,450
114	4,268
116	4,019
118	3,918
120	3,750

**Table 7—Factory Set Blower Connection  
HIGH or LOW Speed**

Control Module	Main Electrical Harness Cable	Blower Wire	Speed
J1-6	Orange	Orange	High
No Connection	No Connection	Blue + Cap	Medium
J1-4	Red	Red	Low

**Table 8—Modify Blower Connection  
HIGH or MEDIUM Speed**

Control Module	Main Electrical Harness Cable	Blower Wire	Speed
J1-6	Orange	Orange	High
J1-4	Red	Blue	Medium
No Connection	No Connection	Red + Cap	Low

**Table 9—Temperature and Voltage**

Outside Temp °F	Standard Defrost (as shipped)	Extended Defrost (Jumper JU1-F Removed)
Above 23°F	No Defrost	No Defrost
23°F to 5°F	6 Minute Defrost/60 Minute Exchange	10 Minute Defrost/30 Minute Exchange
4°F to -17°F	6 Minute Defrost/32 Minute Exchange	10 Minute Defrost/20 Minute Exchange
Below -18°F	6 Minute Defrost/20 Minute Exchange	10 Minute Defrost/15 Minute Exchange

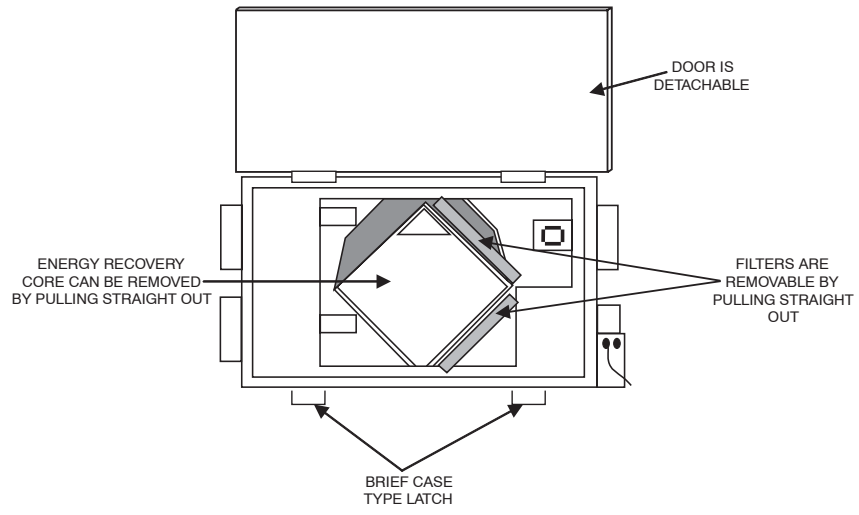

**Fig. 15 - Energy Recover Ventilator**

A99300