

GT-G & GT-S SPLIT (50YCS) & (38WQS) SERIES

SINGLE-STAGE
INDOOR AND OUTDOOR SPLIT SYSTEMS
SIZES 018 - 060 [5.3 - 17.6 kW]

Table of Contents

Design Features - Indoor Units	3
Design Features - Outdoor Units	5
Unit Model Key	9
ARI Performance Certification	10
ARI/ISO/ASHRAE 13256-1 Performance	11
Reference Calculations & Legend	12
Performance Correction Factors.....	12
Performance Data.....	13
Performance Data Selection Notes.....	20
Dimensions.....	21
Physical Data	22
Electrical	23
Electrical Wiring Diagram	24
Equipment Selection.....	26
Engineering Guide Specs.....	28
Accessories & Options.....	30
Warranty Information.....	30
Revision Log.....	31

GT-GS Indoor Split Features

Application Flexibility

- Eight Capacities 018, 024, 030, 036, 042, 048, and 060.
- Voltage availability in 208-230/60/1.
- Stackable cabinets.
- Extended range operation (20-120°F EWT) and flow rates as low as 1.5 gpm per ton.
- Circuit breaker protected loop and hot water generator pumps.
- Field selectable low temperature cut-out selection setting for well or loop.
- Corner located electrical box for wiring access from two sides.
- Compressor mounting springs "matched" to each compressor for maximum quietness.
- Narrow cabinet for movement through doorways.
- Precharged refrigerant circuit with backseating service valves for quick installation.

Operating Efficiencies

- ARI/ASHRAE/ISO 13256-1 ratings for heating COP's, cooling EER's and low water flow rates.
- Operating and temperature range allow shorter loops.
- Optional hot water generator with internal pump generates hot water at considerable savings.
- Rugged, super quiet, and highly efficient scroll compressors.
- Oversized coaxial tube water to refrigerant heat exchangers operate at low liquid pressure drop.
- Convoluted copper (and optional cupronickel) water tube functions efficiently at low-flow rates and provides freeze-damage resistance.

Service Advantages

- Removable panels-3 for compressor.
- Brass swivel-type water and HWG connections for quick connection and elimination of wrenches or sealants during installation.
- Solid state digital compressor module provides reliable lockout, diagnostic, and time delay functions.
- High side loss-of-charge sensing reduces nuisance low pressure faults.
- LED Fault and status indication with memory for easy diagnostics.
- Designed for front-access service in tight applications.
- High and low pressure service ports in the refrigerant circuit.
- Refrigerant sensing freeze protection for more accurate low temperature cut-out.

Factory Quality

- All units are built on our Integrated Process Control Assembly System (IPCS). The IPCS is a unique state of the art manufacturing system that is designed to assure quality of the highest standards of any manufacturer in the water-source industry. Our IPCS system:
 - Verifies that the correct components are being assembled.
 - Automatically performs special leak tests on all joints.
 - Conducts pressure tests.
 - Performs highly detailed run test unparalleled in the HVAC industry.
 - Automatically disables packaging for a "failed" unit.

- Creates computer database for future service analysis and diagnostics from run test results.
- Heavy gauge galvanized steel cabinets are epoxy powder coated for durable and long-lasting finish.
- All refrigerant brazing is done in a nitrogen atmosphere.
- All units are deep evacuated to less than 100 microns prior to refrigerant charging.
- All joints are both helium and halogen leak tested to insure annual leak rate of less than 1/4 ounce.
- Coaxial heat exchanger, refrigerant suction lines and all water lines are fully insulated to eliminate condensation problems in low temperature applications.
- Noise Reduction features include: double isolation mounted compressors, compressor springs, insulated compressor compartment, and interior cabinet insulation using 1/2" coated glass fiber.
- Safety features include: high pressure and loss of charge to protect the compressor; condensate overflow protection; low water temperature limit sensors to safeguard the coaxial heat exchanger and air coil; hot water high limit and low compressor discharge temperature switch provided to shut down the hot water generator when conditions dictate. Fault lockout enables emergency heat and prevents compressor operation until thermostat or circuit breaker has been reset.

Options & Accessories

- Optional hot water generator with internally mounted pump.
- Optional cupronickel coaxial heat exchanger.
- Wide thermostat selection.
- Closed loop flow controller.
- Hose kits.

GT-GS Indoor Split Features

- 1 Copeland™ High Efficiency Scroll Compressor
- 2 Oversized Water Coil
- 3 Fully Insulated Water and Refrigerant Lines
- 4 Optional Factory Installed Hot Water Generator with Internal Pump
- 5 Backseating Brass Service Valves with Service Port
- 6 Brass Swivel Water Connections
- 7 Advanced Digital Controls
- 8 Exclusive Double Spring And Grommet Compressor Isolation For Ultra Quiet Operation
- 9 Three Easy, Lift-out Service Access Panels

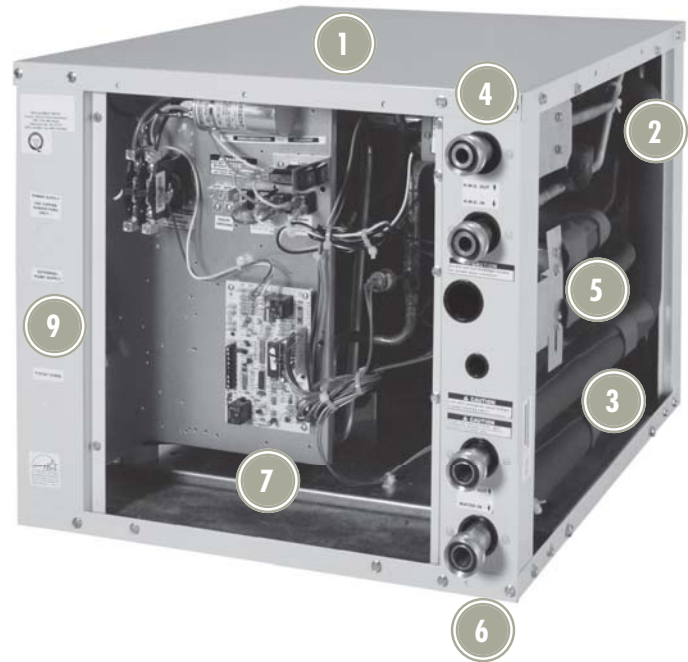

GT-S Outdoor Split Overview

The GT-S Outdoor Split

Carrier Geothermal introduced the industry to the first ever "outdoor" geothermal split system with internal pumping for residential applications. We are giving the consumer choices for unit location! The unit may be installed inside or outside, thereby satisfying the requirements of almost any home. When installed outside, the unit may be placed on an existing pad and easily connected to existing electric service. And with this installation option, the fluid loop remains outside avoiding extensive installation inside the home. The GT-S Outdoor Split is geothermal without the hassle.

Why?

Our GT-S Outdoor Split is taking traditional geothermal technology a step further by offering a unique split system design suitable for any home. Home owners can now enjoy all the savings of a geothermal system with lower installation costs and less hassle. More importantly, the GT-S Outdoor Split is opening up the previously illusive retrofit market. The GT-S Outdoor Split is a competitive product designed to shift traditional air source homeowners to the benefits of water source geothermal technology.

From the utility perspective, the GT-S Outdoor Split just about perfectly embodies what the utility industry has been searching for in geothermal: Lower first cost, simple and easy to service, fits traditional dealer practices and broad market appeal especially for retrofit, etc. The GT-S Outdoor Split can pull geothermal out of its high end niche into more of a mainstream segment.

The Outdoor Split Concept

The GT-S Outdoor Split provides a unique solution to many of the problems associated with single-package geothermal units. In addition, it substantially reduces overall installed costs and perhaps more importantly, opens up the largely untapped retrofit market (which, for conventional equipment, is over 3 times larger than the new construction market).

In new construction, the GT-S Outdoor Split offers many benefits over packaged geothermal units: The fluid loop is kept outside, which keeps large diameter piping, flammable antifreezes and flushing carts (a large, messy service tool) out of the home. The outdoor compressor means noise and most service activity will remain outside. The indoor air handlers are quiet, require less space and allow less costly ductwork (they don't have to be side return with canvas collars and plenum lining). Also, a GT-S Outdoor Split can utilize a gas furnace as the blower and supplemental heat (dual fuel or add-on) which removes a major consumer barrier in that geothermal has traditionally forced the homeowner to make an all-electric home decision. An add-on application also allows the option of sizing the geothermal component to the cooling load, rather than heating, which may further reduce first costs. The GT-S Outdoor Split should be able to tap a larger new construction segment than geothermal currently captures, even when marketed through existing geothermal dealers.

In the replacement market, the GT-S Outdoor Split greatly expands the range of suitable geothermal applications. Current geothermal retrofits have required a complete change out of all existing equipment, elaborate ductwork modifications, complex routing of interior loop fluid lines including below grade foundation penetrations, upgraded electrical service and unit feeders (110v furnace being changed to 240v heat pump with electric backup), and more. This assumes that a geothermal package unit can even be adapted to fit into the existing space. This process is expensive and disruptive to the owner (they typically don't want to change radically from what they have); hence the lack of geothermal retrofits existing. In contrast, the GT-S Outdoor Split can be installed outside on the same line set and electric service supplying the existing air conditioner or heat pump condensing unit. The loop stays outside. Only the indoor coil might need to be changed on an existing furnace, or possibly the air handler on an older heat pump. The purchase timing could be driven by a first-time central cooling addition; the upgrade replacement of an aging or broken air conditioner; heat pump or furnace; an HVAC change necessitated by a renovation; or an efficiency upgrade driven by a utility marketing program.

The GT-S Outdoor Split does not need to be located outside. It can be placed in garages, carports, basements, crawl spaces, etc. This may be important to some homeowners who may be very concerned about outdoor aesthetics. They also can utilize ground water if placed in an appropriate indoor location. Noise is not a problem as the GT-S Outdoor Split is extremely quiet (the box is sealed and insulated). The GT-S Outdoor Split also has excellent heating and latent cooling capacities compared with competitive high efficiency geothermal units. In many cases a GT-S Outdoor Split produces the heating output of one size larger competitor unit. And the Paradigm is likely to be the highest EER per dollar cost unit available in the geothermal industry today.

The goal for the GT-S Outdoor Split Series is based upon application flexibility, efficiency, reliability and a solid state microprocessor compressor control, producing a reliable, simple product both easy to service and install. Its efficiency and application flexibility make it the "Paradigm" of geothermal heat pumps.

GT-S Outdoor Split Overview

Typical Outdoor / Air Handler Installation

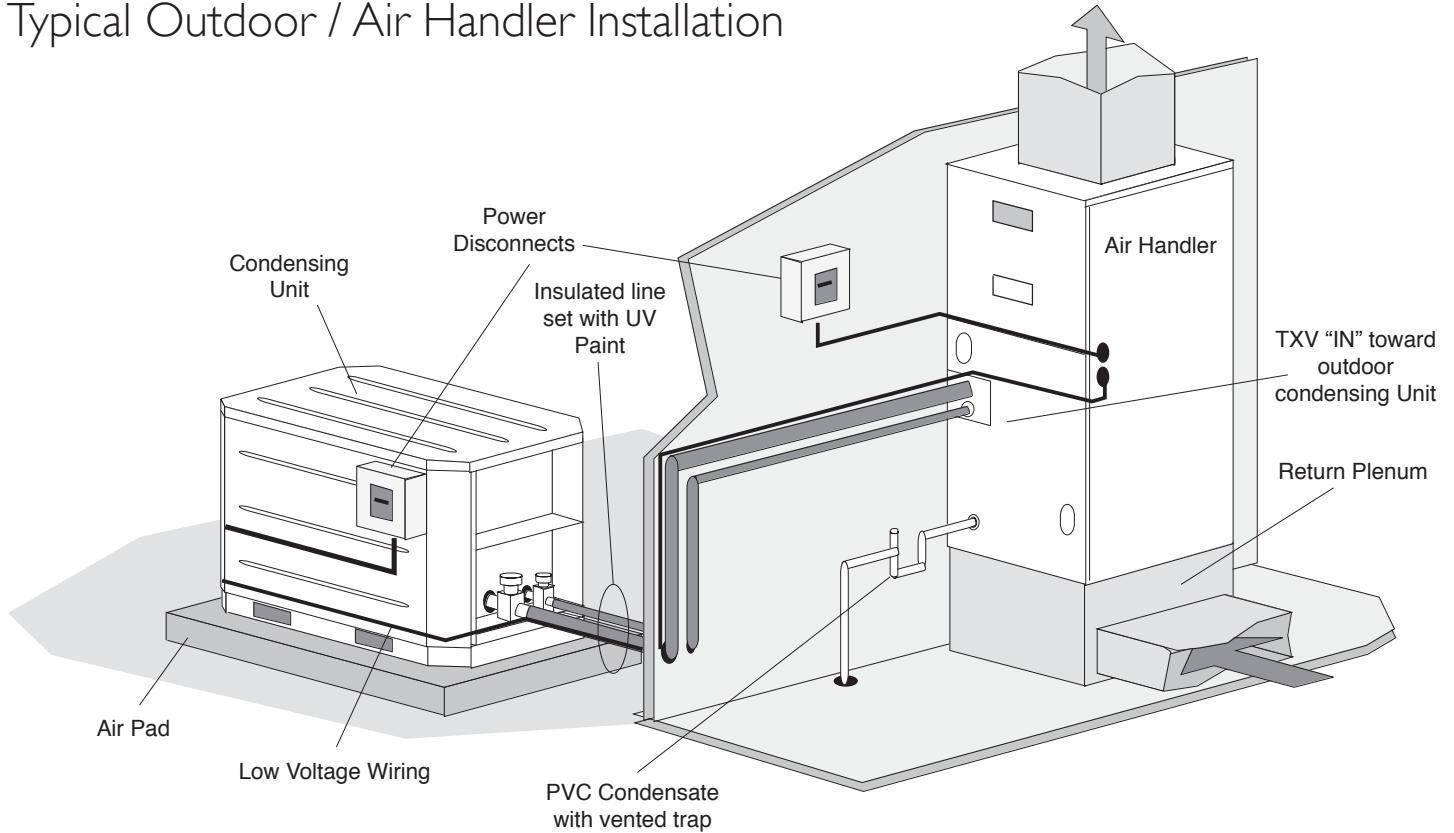

Typical Outdoor / Add-on Coil Installation

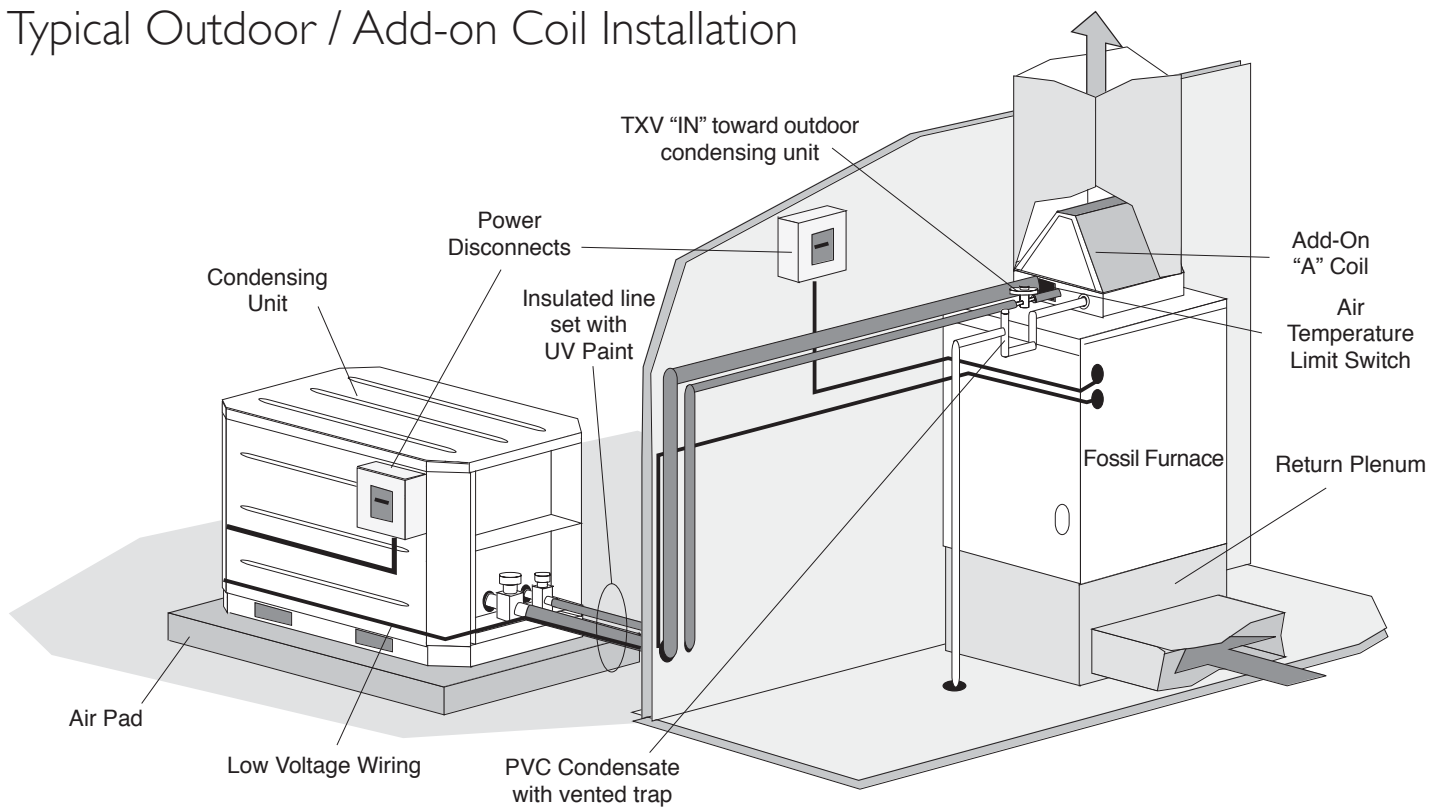

GT-S Outdoor Split Features

Application Flexibility

- Eight Capacities 018, 024, 030, 036, 042, 048, and 060.
- Voltage availability in 208-230/60/1.
- Stackable cabinets.
- Extended range operation (20-120°F EWT) and flow rates as low as 2.25 gpm per ton (geothermal closed loop operation).
- Circuit breaker protected loop and hot water generator pumps.
- Field selectable low temperature cut-out selection setting for geothermal closed loop operation.
- Easily accessible electrical box for wiring.
- Weather-resistant cabinet.
- Internally-mounted (field installed) Flow Controller
- Precharged refrigerant circuit with backseating service valves for quick installation.

Operating Efficiencies

- ARI/ASHRAE/ISO 13256-I ratings for heating COP's, cooling EER's and low water flow rates.
- Operating and temperature range allow shorter loops.
- Optional remoted-mounted hot water generator with internal pump generates hot water at considerable savings.
- Rugged, super quiet, and highly efficient scroll compressors (rotary for size 018).
- Oversized coaxial tube water to refrigerant heat exchangers operate at low liquid pressure drop.
- Convolute copper (and optional cupronickel) water tube functions efficiently at low-flow rates and provides freeze-damage resistance.

Service Advantages

- Removable side and top panels for easy access to water/ refrigerant circuits.
- Low ambient temperature switch activates loop pump in extreme temperatures.
- Solid state digital compressor module provides reliable lockout, diagnostic, and time delay functions.
- High side loss-of-charge sensing reduces nuisance low pressure faults.
- LED Fault and status indication with memory for easy diagnostics.
- High and low pressure service ports in the refrigerant circuit.
- Refrigerant sensing freeze protection for more accurate low temperature cut-out.

Factory Quality

- All units are built on our Integrated Process Control Assembly System (IPCS). The IPCS is a unique state of the art manufacturing system that is designed to assure quality of the highest standards of any manufacturer in the water-source industry. Our IPCS system:
 - Verifies that the correct components are being assembled.
 - Automatically performs special leak tests on all joints.
 - Conducts pressure tests.
 - Performs highly detailed run test unparalleled in the HVAC industry.
 - Automatically disables packaging for a "failed" unit.
 - Creates computer database for future service analysis and diagnostics from run test results.

- Heavy gauge galvanized steel cabinets are epoxy powder coated for durable and long-lasting finish.
- All refrigerant brazing is done in a nitrogen atmosphere.
- All units are deep evacuated to less than 100 microns prior to refrigerant charging.
- All joints are both helium and halogen leak tested to insure annual leak rate of less than 1/4 ounce.
- Coaxial heat exchanger, refrigerant suction lines and all water lines are fully insulated to eliminate condensation problems in low temperature applications.
- Noise Reduction features include: double isolation mounted compressors, compressor springs, insulated compressor compartment, and interior cabinet insulation using 1/2" coated glass fiber.
- Safety features include: high pressure and loss of charge to protect the compressor; condensate overflow protection; low water temperature limit sensors to safeguard the coaxial heat exchanger and air coil; hot water high limit and low compressor discharge temperature switch provided to shut down the hot water generator when conditions dictate. Fault lockout enables emergency heat and prevents compressor operation until thermostat or circuit breaker has been reset.

Options & Accessories

- Optional remote-mounted hot water generator with internally mounted pump.
- Optional cupronickel coaxial heat exchanger.
- Wide thermostat selection.
- Closed loop flow controller.

GT-S Outdoor Split Features

- 1 Copeland™ High Efficiency Scroll Compressor or High Efficiency Rotary (38WQS18)
- 2 Oversized Water Coil
- 3 Fully Insulated Water and Refrigerant Lines
- 4 Powder Coat Painted Weather Resistant Cabinet
- 5 Backseating Brass Service Valves with Service Port
- 6 Brass Water Connections
- 7 Advanced Digital Controls
- 8 Integrated Carrying Handles for Easy Placement on the Jobsite
- 9 Multiple Easy Access Service Panels



GT-GS Indoor Split (50YCS) Series

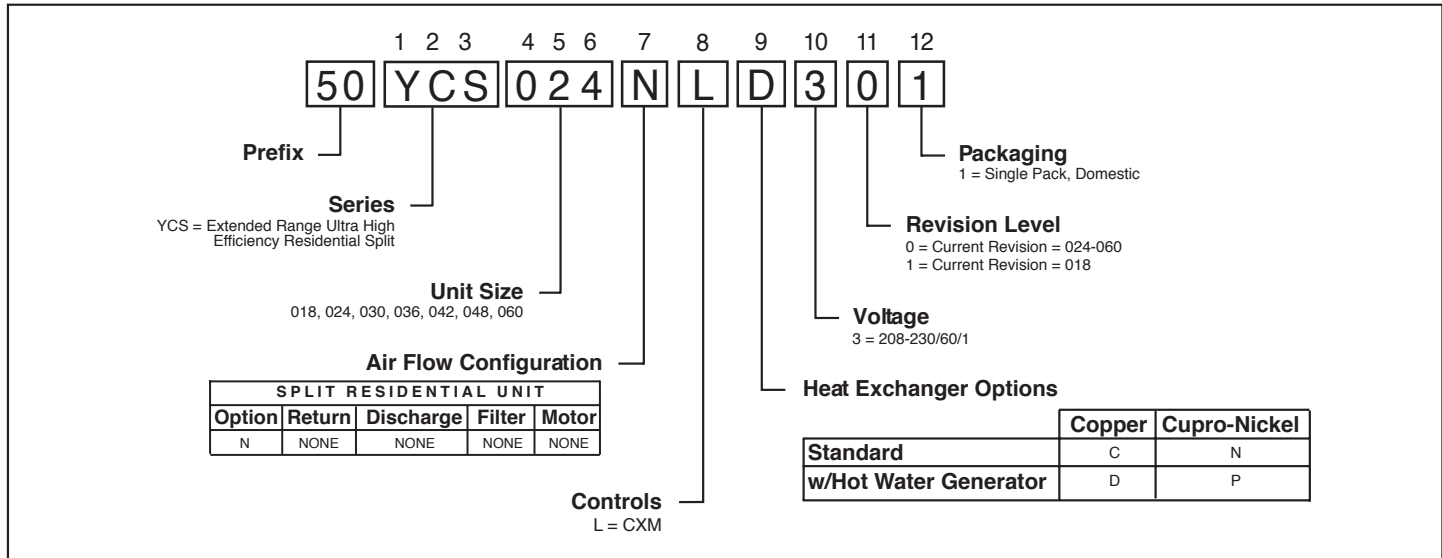

GT-S Outdoor Split (38WQS) Series

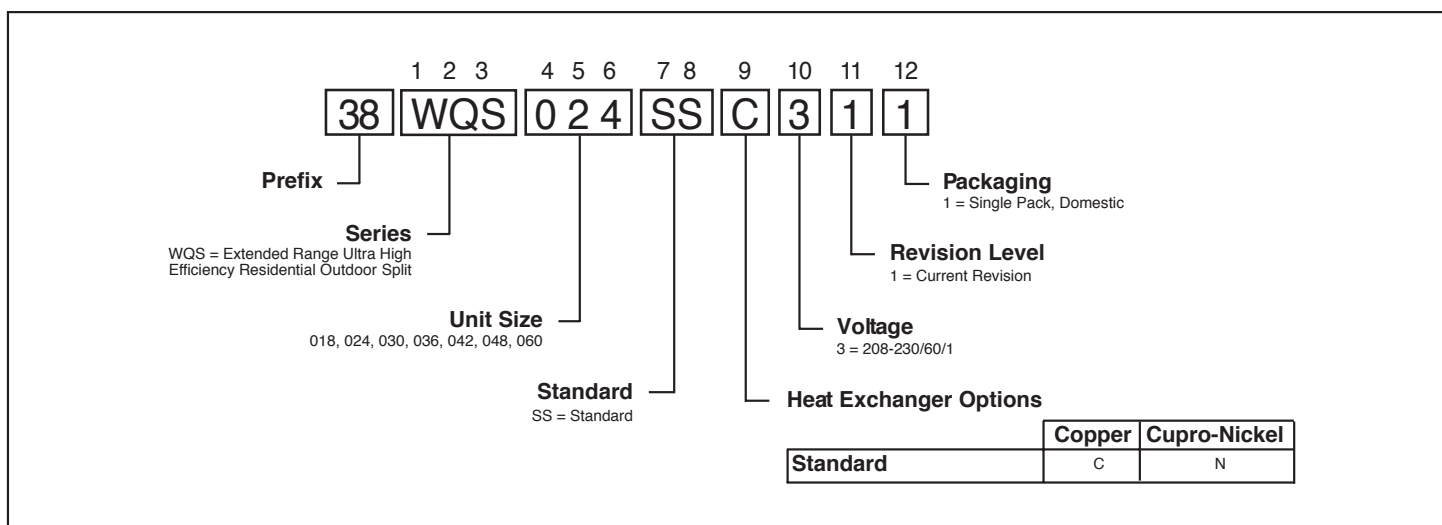

About ARI/ISO/ASHRAE 13256-1

About ARI/ISO/ASHRAE 13256-1

ARI/ASHRAE/ISO 13256-1 (Air-Conditioning and Refrigeration Institute / American Society of Heating, Refrigerating and Air Conditioning Engineers / International Standards Organization) is a certification standard for water-source heat pumps used in the following applications:

- WLHP (Water Loop Heat Pump – Boiler/Tower)
- GWHP (Ground Water Heat Pump – Open Loop)
- GLHP (Ground Loop Heat Pump – Geothermal)

The directory at <http://www.aridirectory.org/ari/wbahp.php> is constantly being updated and immediately available on the Internet. All ratings are submitted by the manufacturer for certification, and must be approved by ARI. Therefore, there is a significant difference between ARI "certified" and ARI "rated." Thirty percent of a manufacturer's basic models must be tested each year. ARI selects models at random from stock for testing on the basis of its evaluation of a participant's certification data.

Units that fail one or more certified test (90% of declared performance or lower) may be declared defective. If the initial failure is a performance test, the manufacturer must obsolete all units within the same basic model group or elect to have a second sample tested. If the second unit fails a performance test, it must be obsoleted, together with all units within the same basic model group. Carrier Geothermal takes certification seriously. We were recently awarded a certificate for consecutive years of no ARI failures.

Temperatures used in ARI certification standards are S.I. (Système International – metric) based. For example, typical catalog data for cooling is shown at 80°F DB / 67°F WB [26.7°C DB / 19.4°C] entering air temperature, but the ARI standard for cooling is 80.6°F DB / 66.2°F WB [27°C DB / 19°C], since it is based upon whole numbers in degrees Celsius. Water and air temperatures for the standard are shown below.

Test Condition Comparison Table

	WLHP	GWHP	GLHP
Cooling			
Entering Air Temperature - DB/WB °F [°C]	80.6/66.2 [27/19]	80.6/66.2 [27/19]	80.6/66.2 [27/19]
Entering Water Temperature - °F [°C]	86 [30]	59 [15]	77 [25]
Fluid Flow Rate	*	*	*
Heating			
Entering Air Temperature - DB/WB °F [°C]	68 [20]	68 [20]	68 [20]
Entering Water Temperature - °F [°C]	68 [20]	50 [10]	32 [0]
Fluid Flow Rate	*	*	*

*Flow rate is specified by the manufacturer

Data certified by ARI include heating/cooling capacities, EER (Energy Efficiency Ratio – Btuh per Watt) and COP (Btuh per Btuh) at the various conditions shown above. Pump power correction is calculated to adjust efficiencies for pumping Watts. Within each model, only one water flow rate is specified for all three groups, and pumping Watts are calculated using the formula below. This additional power is added onto the existing power consumption.

- Pump power correction = $(\text{gpm} \times 0.0631) \times (\text{Press Drop} \times 2990) / 300$

Fan power is corrected to zero external static pressure using the equation below. The nominal airflow is rated at a specific external static pressure. This effectively reduces the power consumption of the unit and increases cooling capacity but decreases heating capacity.

- Fan Power Correction = $(\text{cfm} \times 0.472) \times (\text{esp} \times 249) / 300$

Capacities and efficiencies are calculated using the following equations:

- ISO Cooling Capacity = Cooling Capacity (Btuh) + [Fan Power Correction (Watts) × 3.412]
- ISO EER Efficiency (Btuh/W) = $\text{ISO Cooling Capacity (Btuh)} / [\text{Power Input (Watts)} - \text{Fan Power Correction (Watts)} + \text{Pump Power Correction (Watts)}]$
- ISO Heating Capacity = Heating Capacity (Btuh) – [Fan Power Correction (Watts) × 3.412]
- ISO COP Efficiency (Btuh/Btuh) = $\text{ISO Heating Capacity (Btuh)} \times 3.412 / [\text{Power Input (Watts)} - \text{Fan Power Correction (Watts)} + \text{Pump Power Correction (Watts)}]$

ARI/ISO/ASHRAE/ANSI 13256-1 Performance

ASHRAE/ARI/ISO 13256-1. English (IP) Units

Model	Water Loop Heat Pump				Ground Water Heat Pump				Ground Loop Heat Pump			
	Cooling 86°F		Heating 68°F		Cooling 59°F		Heating 50°F		Cooling 77°F		Heating 32°F	
	Capacity Btuh	EER Btuh/W	Capacity Btuh	COP	Capacity Btuh	EER Btuh/W	Capacity Btuh	COP	Capacity Btuh	EER Btuh/W	Capacity Btuh	COP
018	16,600	14.4	20,300	4.8	18,500	22.1	15,500	4.0	17,800	16.2	12,800	3.5
024	23,500	14.5	29,300	4.7	25,700	20.6	22,800	3.9	25,200	16.6	18,600	3.5
030	28,000	14.7	34,000	4.7	30,200	20.8	26,400	3.9	29,800	16.4	21,500	3.5
036	32,800	14.5	39,200	4.4	34,900	20.1	31,900	3.9	34,700	15.9	25,900	3.3
042	39,800	14.1	48,300	4.7	44,100	19.7	37,800	3.9	42,000	15.5	31,700	3.6
048	44,500	14.2	52,500	4.8	47,500	19.3	42,000	3.9	47,400	15.9	35,800	3.6
060	55,100	13.0	72,700	4.6	57,800	17.2	57,100	3.7	57,600	14.2	47,200	3.5

Cooling capacities based upon 80.6°F DB, 66.2°F WB entering air temperature.

Heating capacities based upon 68°F DB, 59°F WB entering air temperature.

All ratings based upon 208V operation.

ASHRAE/ARI/ISO 13256-1. Metric (SI) Units

Model	Water Loop Heat Pump				Ground Water Heat Pump				Ground Loop Heat Pump			
	Cooling 30°C		Heating 20°C		Cooling 15°C		Heating 10°C		Cooling 25°C		Heating 0°C	
	Capacity Watts	EER W/W	Capacity Watts	COP	Capacity Watts	EER W/W	Capacity Watts	COP	Capacity Watts	EER W/W	Capacity Watts	COP
018	4,865	4.2	5,950	4.8	5,422	6.5	4,543	4.0	5,217	4.7	3,751	3.5
024	6,887	4.2	8,587	4.7	7,532	6.0	6,682	3.9	7,386	4.9	5,451	3.5
030	8,206	4.3	9,965	4.7	8,851	6.1	7,737	3.9	8,734	4.8	6,301	3.5
036	9,613	4.2	11,489	4.4	10,229	5.9	9,349	3.9	10,170	4.7	7,591	3.3
042	11,665	4.1	14,156	4.7	12,925	5.8	11,079	3.9	12,309	4.5	9,291	3.6
048	13,042	4.2	15,387	4.8	13,921	5.7	12,309	3.9	13,892	4.7	10,492	3.6
060	16,149	3.8	21,307	4.6	16,940	5.0	16,735	3.7	16,882	4.2	13,834	3.5

Cooling capacities based upon 80.6°F DB, 66.2°F WB entering air temperature.

Heating capacities based upon 68°F DB, 59°F WB entering air temperature.

All ratings based upon 208V operation.

Reference Calculations, Legend & Performance Correction Factors

Heating		Cooling	
$LWT = EWT - \frac{HE}{GPM \times 500}$	$LAT = EAT + \frac{HC}{CFM \times 1.08}$	$LWT = EWT + \frac{HR}{GPM \times 500}$	$LAT (DB) = EAT (DB) - \frac{SC}{CFM \times 1.08}$
		$LC = TC - SC$	$S/T = \frac{SC}{TC}$

CFM = airflow, cubic feet/minute	HE = total heat of extraction, Mbtuh
EWT = entering water temperature, °F	HWC = Hot Water Generator (desuperheater) capacity, Mbtuh
GPM = water flow in US gallons/minute	WPD = Water coil pressure drop (psi & ft hd)
EAT = entering air temperature, Fahrenheit (dry bulb/wet bulb)	EER = Energy Efficiency Ratio = BTU output/Watt input
HC = air heating capacity, Mbtuh	COP = Coefficient of Performance = BTU output/BTU input
TC = total cooling capacity, Mbtuh	LWT = leaving water temperature, °F
SC = sensible cooling capacity, Mbtuh	LAT = leaving air temperature, °F
KW = total power unit input, KiloWatts	LC = latent cooling capacity, Mbtuh
HR = total heat of rejection, Mbtuh	S/T = sensible to total cooling ratio

Performance Correction Factors

Heating Corrections			
Entering Air DB, °F	Heating Capacity	Power	Heat of Extraction
60	1.019	0.896	1.054
65	1.010	0.948	1.028
68	1.004	0.980	1.011
70	1.000	1.000	1.000
75	0.997	1.059	0.979
80	0.993	1.118	0.957

Cooling Corrections										
Entering Air WB, °F	Total Cooling Capacity	Sensible Cooling Capacity Multiplier - Entering DB °F							Power	Heat of Rejection
		70	75	80	80.6	85	90	95		
60	0.881	0.943	1.067	1.192	1.240	*	*	*	0.983	0.899
65	0.940	0.797	0.952	1.106	1.125	1.261	*	*	0.991	0.949
66.2	0.976	0.693	0.868	1.043	1.063	1.217	*	*	0.997	0.980
67	1.000	0.624	0.812	1.000	1.023	1.188	1.343	1.352	1.000	1.000
70	1.012		0.697	0.820	0.835	0.944	1.067	1.257	1.002	1.010
75	1.024			0.637	0.658	0.817	0.983	1.159	1.005	1.019

* Sensible capacity equals total capacity (no latent capacity) at conditions shown as "**".

ARI/ISO/ASHRAE 13256-1 uses entering air conditions of Cooling - 80.6°F DB/ 66.2°F WB and Heating - 68°F DB/59° WB

Performance Data — 50YCS018 / 38WQS18 With GAH018

475 CFM Nominal (Rated) Airflow Cooling, 600 CFM Nominal (Rated) Airflow Heating

Performance capacities shown in thousands of Btuh

EWT °F	GPM	WPD		Cooling - EAT 80/67°F							Heating - EAT 70°F					
		PSI	FT	Airflow CFM	TC	SC	kW	HR	EER	HWC	HC	kW	HE	LAT	COP	HWC
20	4.5	1.8	4.2	Operation not recommended							11.6	1.13	7.8	92.6	3.01	1.5
	4.5	1.8	4.2	Operation not recommended							11.7	1.08	8.0	88.1	3.18	1.3
30	2.2	0.5	1.2	475	22.5	13.9	0.57	24.4	39.4	0.6	11.8	1.05	8.2	92.9	3.28	1.7
	2.2	0.5	1.2	600	23.6	16.0	0.59	25.6	40.0	0.5	12.1	1.04	8.5	88.6	3.41	1.5
	3.5	1.1	2.6	475	21.9	13.7	0.53	23.7	41.0	0.6	12.5	1.12	8.7	94.3	3.28	1.8
	3.5	1.1	2.6	600	23.0	15.6	0.55	24.9	41.5	0.5	12.7	1.08	9.0	89.6	3.43	1.5
	4.5	1.8	4.1	475	21.3	13.5	0.50	23.0	42.7	0.6	13.2	1.18	9.2	95.7	3.28	1.9
	4.5	1.8	4.1	600	22.4	15.3	0.52	24.2	43.2	0.5	13.3	1.13	9.5	90.6	3.45	1.6
40	2.2	0.5	1.1	475	21.5	13.5	0.71	23.9	30.3	1.1	13.9	1.13	10.0	97.0	3.61	2.0
	2.2	0.5	1.1	600	22.6	15.5	0.74	25.1	30.7	1.0	14.2	1.11	10.4	91.9	3.76	1.8
	3.5	1.1	2.5	475	21.0	13.3	0.67	23.3	31.5	1.0	14.6	1.17	10.6	98.4	3.64	2.1
	3.5	1.1	2.5	600	22.1	15.2	0.69	24.4	31.9	1.0	14.7	1.13	10.8	92.7	3.80	1.8
	4.5	1.7	3.9	475	20.5	13.1	0.62	22.6	32.8	0.9	15.3	1.22	11.1	99.8	3.68	2.2
	4.5	1.7	3.9	600	21.6	14.9	0.65	23.8	33.2	0.9	15.2	1.16	11.2	93.4	3.84	1.9
50	2.2	0.5	1.1	475	20.5	13.1	0.85	23.4	24.1	1.6	16.0	1.20	11.9	101.1	3.90	2.4
	2.2	0.5	1.1	600	21.5	15.1	0.88	24.5	24.5	1.5	16.3	1.18	12.3	95.2	4.06	2.0
	3.5	1.1	2.5	475	20.1	13.0	0.80	22.8	25.1	1.4	16.7	1.23	12.5	102.5	3.98	2.4
	3.5	1.1	2.5	600	21.1	14.8	0.83	23.9	25.4	1.4	16.7	1.18	12.6	95.7	4.14	2.1
	4.5	1.7	3.8	475	19.7	12.8	0.75	22.2	26.2	1.2	17.3	1.25	13.1	103.8	4.06	2.5
	4.5	1.7	3.8	600	20.7	14.5	0.78	23.3	26.5	1.3	17.0	1.18	13.0	96.2	4.22	2.2
60	2.2	0.5	1.0	475	19.5	12.7	0.98	22.8	19.9	2.0	18.2	1.28	13.8	105.4	4.18	2.7
	2.2	0.5	1.0	600	20.4	14.6	1.01	23.8	20.3	2.0	18.5	1.25	14.2	98.5	4.33	2.3
	3.5	1.0	2.4	475	19.4	12.7	0.92	22.5	21.0	1.8	18.8	1.28	14.4	106.6	4.30	2.8
	3.5	1.0	2.4	600	20.3	14.4	0.95	23.5	21.4	1.8	19.1	1.24	14.9	99.5	4.51	2.4
	4.5	1.6	3.7	475	19.2	12.6	0.87	22.2	22.2	1.6	19.4	1.29	15.0	107.8	4.41	2.8
	4.5	1.6	3.7	600	20.2	14.1	0.89	23.2	22.6	1.7	19.7	1.23	15.5	100.4	4.69	2.5
70	2.2	0.4	1.0	475	18.5	12.4	1.11	22.2	16.7	2.4	20.4	1.35	15.8	109.8	4.43	3.0
	2.2	0.4	1.0	600	19.2	14.2	1.13	23.0	17.0	2.4	20.6	1.33	16.1	101.9	4.56	2.6
	3.5	1.0	2.3	475	18.6	12.4	1.04	22.2	17.8	2.2	20.9	1.34	16.4	110.8	4.59	3.1
	3.5	1.0	2.3	600	19.4	14.0	1.07	23.1	18.2	2.2	21.5	1.30	17.1	103.2	4.84	2.7
	4.5	1.5	3.6	475	18.8	12.4	0.98	22.1	19.1	2.0	21.5	1.33	17.0	111.9	4.75	3.2
	4.5	1.5	3.6	600	19.6	13.8	1.01	23.1	19.5	2.1	22.4	1.28	18.1	104.6	5.13	2.8
80	2.2	0.4	1.0	475	17.5	12.0	1.26	21.8	14.0	2.7	22.5	1.42	17.7	113.9	4.63	3.3
	2.2	0.4	1.0	600	18.2	13.7	1.28	22.6	14.2	2.8	22.8	1.40	18.0	105.2	4.78	2.9
	3.5	1.0	2.2	475	17.7	12.0	1.19	21.7	14.9	2.5	22.8	1.39	18.1	114.5	4.80	3.5
	3.5	1.0	2.2	600	18.4	13.5	1.21	22.6	15.2	2.6	23.5	1.36	18.8	106.2	5.07	3.0
	4.5	1.5	3.5	475	17.8	12.0	1.12	21.6	16.0	2.4	23.1	1.36	18.5	115.1	4.98	3.6
	4.5	1.5	3.5	600	18.6	13.3	1.14	22.5	16.3	2.4	24.2	1.32	19.7	107.3	5.38	3.1
90	2.2	0.4	0.9	475	16.6	11.6	1.41	21.4	11.8	3.1	24.6	1.50	19.5	118.0	4.82	3.7
	2.2	0.4	0.9	600	17.2	13.3	1.44	22.1	12.0	3.2	24.9	1.47	19.9	108.5	4.97	3.1
	3.5	0.9	2.1	475	16.7	11.6	1.33	21.2	12.6	2.9	24.7	1.45	19.8	118.2	5.00	3.8
	3.5	0.9	2.1	600	17.4	13.1	1.36	22.1	12.8	3.0	25.4	1.41	20.6	109.2	5.28	3.3
	4.5	1.4	3.3	475	16.8	11.6	1.25	21.1	13.5	2.7	24.8	1.40	20.0	118.4	5.20	4.0
	4.5	1.4	3.3	600	17.6	12.9	1.28	22.0	13.8	2.8	25.9	1.35	21.3	110.0	5.62	3.4
100	2.2	0.4	0.9	475	15.5	11.1	1.54	20.8	10.1	3.5	Operation not recommended					
	2.2	0.4	0.9	600	16.1	12.8	1.58	21.5	10.2	3.6						
	3.5	0.9	2.1	475	15.7	11.1	1.46	20.6	10.7	3.3						
	3.5	0.9	2.1	600	16.3	12.6	1.49	21.4	10.9	3.4						
	4.5	1.4	3.2	475	15.8	11.1	1.37	20.5	11.5	3.1						
	4.5	1.4	3.2	600	16.5	12.4	1.41	21.3	11.8	3.2						
110	2.2	0.4	0.9	475	14.5	10.7	1.68	20.2	8.6	3.9	Operation not recommended					
	2.2	0.4	0.9	600	15.1	12.3	1.72	20.9	8.8	4.1						
	3.5	0.9	2.0	475	14.6	10.7	1.59	20.0	9.2	3.7						
	3.5	0.9	2.0	600	15.3	12.1	1.63	20.8	9.4	3.8						
	4.5	1.3	3.1	475	14.7	10.7	1.49	19.8	9.9	3.5						
	4.5	1.3	3.1	600	15.4	11.9	1.53	20.7	10.1	3.6						

Interpolation is permissible; extrapolation is not.

All entering air conditions are 80°F DB and 67°F WB in cooling, and 70°F DB in heating.

ARI/ISO certified conditions are 80.6°F DB and 66.2°F WB in cooling and 68°F DB in heating.

Table does not reflect fan or pump power corrections for ARI/ISO conditions.

All performance is based upon the lower voltage of dual voltage rated units.

Operation below 40°F EWT is based upon a 15% antifreeze solution.

Operation below 60°F EWT requires optional insulated water/refrigerant circuit (standard on residential models).

See performance correction tables for operating conditions other than those listed above.

For operation in the shaded areas, please see the Performance Data Selection Notes on Page 20.

GT-GS & GT-S (50YCS) & (38WQS) Series

Performance Data — 50YCS024 / 38WQS24 With GAH024

650 CFM Nominal (Rated) Airflow Cooling, 800 CFM Nominal (Rated) Airflow Heating

Performance capacities shown in thousands of Btuh

EWT °F	GPM	WPD		Cooling - EAT 80/67°F							Heating - EAT 70°F					
		PSI	FT	Airflow CFM	TC	SC	kW	HR	EER	HWC	HC	kW	HE	LAT	COP	HWC
20	6.0	1.7	3.9	Operation not recommended							16	1.62	10.5	92.8	2.89	2.1
	6.0	1.7	3.9	Operation not recommended							16.2	1.59	10.8	88.7	2.99	1.8
30	3.0	0.4	0.9	650	29.4	19.3	0.92	32.6	32.1	0.9	18.9	1.69	13.2	97.0	3.29	2.4
	3.0	0.4	0.9	800	31.0	21.2	0.94	34.2	33.0	0.8	19.2	1.62	13.7	92.3	3.48	2.0
	4.5	0.9	2.1	650	30.0	19.6	0.89	33.0	33.8	1.0	19.1	1.69	13.4	97.2	3.32	2.5
	4.5	0.9	2.1	800	31.0	21.2	0.91	34.1	34.3	0.8	19.4	1.64	13.8	92.4	3.47	2.1
	6.0	1.6	3.8	650	30.6	19.9	0.86	33.5	35.6	1.0	19.3	1.69	13.5	97.5	3.35	2.6
	6.0	1.6	3.8	800	31.1	21.2	0.87	34.1	35.6	0.8	19.5	1.65	13.9	92.6	3.47	2.2
40	3.0	0.4	0.9	650	28.7	18.7	1.10	32.4	26.2	1.6	21.5	1.75	15.6	100.7	3.60	2.8
	3.0	0.4	0.9	800	30.2	20.6	1.12	34.0	26.9	1.4	21.9	1.69	16.1	95.3	3.80	2.4
	4.5	0.9	2.1	650	29.2	19.0	1.06	32.8	27.6	1.5	21.9	1.77	15.9	101.2	3.63	2.9
	4.5	0.9	2.1	800	30.2	20.6	1.08	33.9	28.0	1.4	22.2	1.70	16.3	95.6	3.81	2.5
	6.0	1.6	3.7	650	29.7	19.3	1.02	33.1	29.1	1.3	22.3	1.78	16.2	101.8	3.67	3.0
	6.0	1.6	3.7	800	30.2	20.6	1.04	33.8	29.2	1.3	22.5	1.72	16.6	96.0	3.82	2.6
50	3.0	0.4	0.9	650	27.9	18.2	1.28	32.3	21.9	2.2	24.1	1.82	17.9	104.4	3.88	3.2
	3.0	0.4	0.9	800	29.4	20.0	1.31	33.8	22.5	2.1	24.5	1.75	18.5	98.3	4.10	2.8
	4.5	0.9	2.0	650	28.4	18.4	1.23	32.5	23.1	2.0	24.7	1.85	18.4	105.2	3.92	3.3
	4.5	0.9	2.0	800	29.3	20.0	1.25	33.6	23.4	2.0	24.9	1.77	18.9	98.9	4.13	2.9
	6.0	1.6	3.6	650	28.8	18.7	1.18	32.8	24.4	1.7	25.3	1.87	18.9	106.1	3.96	3.4
	6.0	1.6	3.6	800	29.3	20.0	1.20	33.4	24.4	1.8	25.4	1.79	19.3	99.4	4.16	3.0
60	3.0	0.4	0.9	650	27.0	18.0	1.42	31.9	19.0	2.7	26.6	1.90	20.1	107.9	4.09	3.6
	3.0	0.4	0.9	800	28.4	19.6	1.46	33.4	19.5	2.7	27.1	1.82	20.9	101.4	4.38	3.2
	4.5	0.8	1.9	650	27.2	18.1	1.36	31.9	20.0	2.4	27.5	1.93	20.9	109.1	4.16	3.8
	4.5	0.8	1.9	800	28.2	19.6	1.39	32.9	20.3	2.5	27.9	1.84	21.6	102.3	4.43	3.3
	6.0	1.5	3.5	650	27.4	18.3	1.30	31.9	21.2	2.2	28.4	1.96	21.7	110.4	4.23	3.9
	6.0	1.5	3.5	800	28.0	19.7	1.32	32.5	21.2	2.3	28.7	1.87	22.3	103.2	4.49	3.4
70	3.0	0.4	0.8	650	26.1	17.8	1.57	31.5	16.7	3.2	29.0	1.98	22.3	111.3	4.29	4.1
	3.0	0.4	0.8	800	27.5	19.3	1.61	33.0	17.1	3.2	29.7	1.88	23.3	104.4	4.63	3.5
	4.5	0.8	1.9	650	26.1	17.9	1.49	31.2	17.5	2.9	30.2	2.02	23.3	113.0	4.38	4.2
	4.5	0.8	1.9	800	27.0	19.3	1.53	32.3	17.7	3.0	30.8	1.92	24.3	105.7	4.72	3.7
	6.0	1.5	3.4	650	26.1	18.0	1.41	30.9	18.4	2.7	31.4	2.06	24.4	114.7	4.47	4.3
	6.0	1.5	3.4	800	26.6	19.4	1.44	31.5	18.4	2.8	32.0	1.95	25.3	107.0	4.80	3.8
80	3.0	0.3	0.8	650	25.4	17.1	1.77	31.5	14.4	3.6	31.6	2.05	24.6	115.0	4.51	4.5
	3.0	0.3	0.8	800	26.8	18.5	1.81	32.9	14.8	3.7	32.4	1.95	25.7	107.4	4.87	3.9
	4.5	0.8	1.8	650	25.4	17.2	1.68	31.1	15.1	3.4	32.9	2.09	25.8	116.9	4.60	4.7
	4.5	0.8	1.8	800	26.3	18.6	1.72	32.2	15.3	3.5	33.6	1.99	26.8	108.9	4.96	4.0
	6.0	1.4	3.2	650	25.4	17.2	1.59	30.8	16.0	3.1	34.3	2.14	27.0	118.8	4.69	4.8
	6.0	1.4	3.2	800	25.9	18.6	1.62	31.4	15.9	3.2	34.9	2.03	28.0	110.4	5.04	4.2
90	3.0	0.3	0.8	650	24.7	16.4	1.96	31.4	12.6	4.1	34.2	2.12	26.9	118.6	4.72	5.0
	3.0	0.3	0.8	800	26.0	17.7	2.01	32.9	12.9	4.3	35.0	2.01	28.1	110.5	5.10	4.2
	4.5	0.8	1.7	650	24.7	16.4	1.86	31.1	13.3	3.9	35.6	2.17	28.2	120.8	4.81	5.2
	4.5	0.8	1.7	800	25.6	17.8	1.91	32.1	13.4	4.0	36.4	2.06	29.4	112.1	5.18	4.4
	6.0	1.4	3.1	650	24.7	16.5	1.77	30.7	14.0	3.6	37.1	2.22	29.5	122.9	4.89	5.4
	6.0	1.4	3.1	800	25.2	17.9	1.80	31.3	14.0	3.7	37.8	2.11	30.6	113.8	5.25	4.6
100	3.0	0.3	0.7	650	23.4	15.9	2.20	30.9	10.6	4.6	Operation not recommended					
	3.0	0.3	0.7	800	24.6	17.2	2.26	32.3	10.9	4.8						
	4.5	0.7	1.7	650	23.3	16.0	2.09	30.5	11.2	4.4						
	4.5	0.7	1.7	800	24.2	17.3	2.14	31.5	11.3	4.5						
	6.0	1.3	3.0	650	23.3	16.0	1.98	30.1	11.8	4.1						
	6.0	1.3	3.0	800	23.8	17.3	2.02	30.7	11.8	4.2						
110	3.0	0.3	0.7	650	22.0	15.4	2.44	30.3	9.0	5.1	Operation not recommended					
	3.0	0.3	0.7	800	23.2	16.7	2.50	31.7	9.3	5.3						
	4.5	0.7	1.6	650	22.0	15.5	2.32	29.9	9.5	4.8						
	4.5	0.7	1.6	800	22.8	16.7	2.37	30.9	9.6	5.0						
	6.0	1.3	2.9	650	21.9	15.5	2.20	29.4	10.0	4.6						
	6.0	1.3	2.9	800	22.4	16.8	2.24	30.0	10.0	4.7						

Interpolation is permissible; extrapolation is not.
 All entering air conditions are 80°F DB and 67°F WB in cooling, and 70°F DB in heating.
 ARI/ISO certified conditions are 80.6°F DB and 66.2°F WB in cooling and 68°F DB in heating.
 Table does not reflect fan or pump power corrections for ARI/ISO conditions.
 All performance is based upon the lower voltage of dual voltage rated units.
 Operation below 40°F EWT is based upon a 15% antifreeze solution.
 Operation below 60°F EWT requires optional insulated water/refrigerant circuit (standard on residential models).
 See performance correction tables for operating conditions other than those listed above.
 For operation in the shaded areas, please see the Performance Data Selection Notes on Page 20.

Performance Data — 50YCS030 / 38WQS30 With GAH030

800 CFM Nominal (Rated) Airflow Cooling, 1000 CFM Nominal (Rated) Airflow Heating

Performance capacities shown in thousands of Btuh

EWT °F	GPM	WPD		Cooling - EAT 80/67°F							Heating - EAT 70°F					
		PSI	FT	Airflow CFM	TC	SC	kW	HR	EER	HWC	HC	kW	HE	LAT	COP	HWC
20	7.5	2.7	6.2	Operation not recommended							18.4	1.92	11.9	91.3	2.82	2.6
	7.5	2.7	6.2	Operation not recommended							18.6	1.88	12.2	87.2	2.91	2.2
30	3.7	0.6	1.4	800	34.5	22.6	1.09	38.2	31.6	1.1	20.6	1.97	13.9	93.8	3.06	2.9
	3.7	0.6	1.4	1000	36.0	25.2	1.04	39.5	34.4	0.9	20.7	1.92	14.1	89.1	3.15	2.5
	5.5	1.4	3.2	800	34.6	22.4	1.07	38.3	32.4	1.1	21.5	1.96	14.8	94.9	3.20	3.0
	5.5	1.4	3.2	1000	36.0	24.7	1.09	39.7	33.1	1.0	21.6	1.92	15.1	90.0	3.30	2.6
	7.5	2.6	6.0	800	34.8	22.2	1.05	38.4	33.2	1.2	22.4	1.96	15.7	95.9	3.35	3.2
	7.5	2.6	6.0	1000	36.1	24.1	1.14	40.0	31.8	1.0	22.6	1.92	16.1	90.9	3.45	2.7
40	3.7	0.6	1.4	800	33.5	22.3	1.31	37.9	25.5	1.9	24.0	2.03	17.1	97.8	3.48	3.4
	3.7	0.6	1.4	1000	34.9	25.0	1.25	39.2	27.8	1.8	24.1	1.98	17.4	92.4	3.58	3.0
	5.5	1.3	3.1	800	33.6	22.2	1.26	37.9	26.7	1.8	24.9	2.04	18.0	98.9	3.58	3.6
	5.5	1.3	3.1	1000	34.9	24.4	1.28	39.3	27.3	1.7	24.9	1.98	18.2	93.1	3.68	3.1
	7.5	2.5	5.8	800	33.7	22.1	1.20	37.8	28.0	1.6	25.8	2.06	18.8	99.9	3.68	3.7
	7.5	2.5	5.8	1000	35.0	23.9	1.31	39.5	26.8	1.6	25.7	1.99	18.9	93.8	3.78	3.2
50	3.7	0.6	1.3	800	32.4	22.1	1.53	37.7	21.2	2.7	27.5	2.08	20.4	101.8	3.87	4.0
	3.7	0.6	1.3	1000	33.8	24.7	1.47	38.8	23.1	2.6	27.6	2.03	20.7	95.6	3.99	3.4
	5.5	1.3	3.0	800	32.6	22.0	1.45	37.5	22.5	2.4	28.4	2.12	21.2	102.8	3.93	4.1
	5.5	1.3	3.0	1000	33.9	24.2	1.47	38.9	23.0	2.4	28.2	2.05	21.2	96.1	4.04	3.6
	7.5	2.4	5.6	800	32.7	21.9	1.36	37.3	24.0	2.1	29.3	2.16	21.9	103.9	3.98	4.2
	7.5	2.4	5.6	1000	33.9	23.8	1.48	39.0	23.0	2.2	28.8	2.06	21.8	96.6	4.09	3.7
60	3.7	0.6	1.3	800	31.2	21.4	1.66	36.9	18.8	3.3	31.0	2.17	23.6	105.8	4.19	4.5
	3.7	0.6	1.3	1000	32.7	23.8	1.67	38.3	19.6	3.3	31.1	2.09	24.0	98.8	4.37	3.9
	5.5	1.3	2.9	800	31.2	21.1	1.59	36.7	19.7	3.0	31.8	2.21	24.3	106.8	4.22	4.6
	5.5	1.3	2.9	1000	32.7	23.5	1.62	38.3	20.2	3.0	32.0	2.11	24.8	99.6	4.45	4.1
	7.5	2.4	5.4	800	31.2	20.8	1.52	36.4	20.6	2.7	32.7	2.25	25.0	107.9	4.25	4.8
	7.5	2.4	5.4	1000	32.8	23.1	1.58	38.2	20.7	2.8	32.9	2.13	25.6	100.4	4.52	4.2
70	3.7	0.5	1.3	800	30.0	20.7	1.79	36.2	16.8	3.9	34.4	2.25	26.8	109.9	4.48	5.0
	3.7	0.5	1.3	1000	31.5	23.0	1.87	37.9	16.9	3.9	34.6	2.14	27.3	102.0	4.73	4.4
	5.5	1.2	2.8	800	29.9	20.2	1.73	35.8	17.3	3.6	35.3	2.30	27.4	110.8	4.50	5.2
	5.5	1.2	2.8	1000	31.6	22.8	1.78	37.7	17.8	3.7	35.8	2.17	28.4	103.1	4.83	4.5
	7.5	2.3	5.3	800	29.7	19.7	1.67	35.5	17.8	3.3	36.1	2.35	28.1	111.8	4.51	5.3
	7.5	2.3	5.3	1000	31.7	22.5	1.69	37.5	18.8	3.4	37.0	2.20	29.5	104.2	4.92	4.7
80	3.7	0.5	1.2	800	29.0	20.7	2.00	35.9	14.5	4.5	37.9	2.31	30.0	113.9	4.81	5.6
	3.7	0.5	1.2	1000	30.5	23.0	2.08	37.6	14.7	4.6	38.0	2.20	30.5	105.2	5.08	4.8
	5.5	1.2	2.7	800	28.9	20.2	1.93	35.5	15.0	4.2	38.6	2.37	30.5	114.7	4.77	5.8
	5.5	1.2	2.7	1000	30.6	22.7	1.98	37.3	15.4	4.3	39.1	2.24	31.5	106.2	5.12	5.0
	7.5	2.2	5.1	800	28.7	19.7	1.87	35.1	15.4	3.9	39.3	2.44	31.0	115.5	4.73	6.0
	7.5	2.2	5.1	1000	30.6	22.5	1.89	37.1	16.3	4.0	40.2	2.28	32.4	107.2	5.17	5.2
90	3.7	0.5	1.2	800	28.0	20.7	2.20	35.5	12.7	5.1	41.4	2.37	33.3	117.9	5.12	6.2
	3.7	0.5	1.2	1000	29.4	23.0	2.30	37.3	12.8	5.3	41.5	2.25	33.8	108.4	5.41	5.2
	5.5	1.1	2.6	800	27.9	20.2	2.13	35.2	13.1	4.8	41.9	2.44	33.6	118.5	5.03	6.4
	5.5	1.1	2.6	1000	29.5	22.7	2.19	37.0	13.5	4.9	42.5	2.31	34.6	109.3	5.40	5.5
	7.5	2.1	4.9	800	27.7	19.7	2.06	34.8	13.5	4.5	42.5	2.52	33.9	119.2	4.94	6.7
	7.5	2.1	4.9	1000	29.6	22.5	2.08	36.7	14.2	4.6	43.5	2.36	35.4	110.3	5.4	5.7
100	3.7	0.5	1.1	800	26.4	19.6	2.39	34.6	11.0	5.8	Operation not recommended					
	3.7	0.5	1.1	1000	27.7	21.8	2.49	36.2	11.1	6.0						
	5.5	1.1	2.5	800	26.3	19.2	2.32	34.2	11.4	5.4						
	5.5	1.1	2.5	1000	27.8	21.6	2.38	35.9	11.7	5.6						
	7.5	2.0	4.7	800	26.2	18.7	2.24	33.8	11.7	5.1						
	7.5	2.0	4.7	1000	27.9	21.3	2.26	35.6	12.3	5.2						
110	3.7	0.5	1.1	800	24.8	18.6	2.58	33.6	9.6	6.4	Operation not recommended					
	3.7	0.5	1.1	1000	26.0	20.6	2.69	35.2	9.7	6.7						
	5.5	1.1	2.4	800	24.7	18.1	2.50	33.2	9.9	6.0						
	5.5	1.1	2.4	1000	26.1	20.4	2.57	34.9	10.2	6.2						
	7.5	2.0	4.5	800	24.6	17.7	2.42	32.8	10.2	5.7						
	7.5	2.0	4.5	1000	26.2	20.2	2.44	34.5	10.7	5.8						

Interpolation is permissible; extrapolation is not.

All entering air conditions are 80°F DB and 67°F WB in cooling, and 70°F DB in heating.

ARI/ISO certified conditions are 80.6°F DB and 66.2°F WB in cooling and 68°F DB in heating.

Table does not reflect fan or pump power corrections for ARI/ISO conditions.

All performance is based upon the lower voltage of dual voltage rated units.

Operation below 40°F EWT is based upon a 15% antifreeze solution.

Operation below 60°F EWT requires optional insulated water/refrigerant circuit (standard on residential models).

See performance correction tables for operating conditions other than those listed above.

For operation in the shaded areas, please see the Performance Data Selection Notes on Page 20.

GT-GS & GT-S (50YCS) & (38WQS) Series

Performance Data — 50YCS036 / 38WQS36 With GAH036

975 CFM Nominal (Rated) Airflow Cooling, 1200 CFM Nominal (Rated) Airflow Heating

Performance capacities shown in thousands of Btuh

EWT °F	GPM	WPD		Cooling - EAT 80/67°F							Heating - EAT 70°F					
		PSI	FT	Airflow CFM	TC	SC	kW	HR	EER	HWC	HC	kW	HE	LAT	COP	HWC
20	9.0	4.9	11.2	Operation not recommended							23.1	2.15	15.7	91.9	3.14	3.2
	9.0	4.9	11.2								22.9	2.23	15.3	87.7	3.01	2.7
30	4.5	1.6	3.7	975	41.8	27.1	1.32	46.3	31.6	1.2	25.6	2.38	17.5	94.3	3.14	3.6
	4.5	1.6	3.7	1200	42.2	29.1	1.38	46.9	30.5	1.1	25.9	2.30	18.1	90.0	3.30	3.0
	7.0	3.2	7.3	975	41.7	27.3	1.27	46.1	32.9	1.3	26.2	2.31	18.3	94.9	3.32	3.7
	7.0	3.2	7.3	1200	42.0	29.4	1.33	46.5	31.7	1.1	26.3	2.31	18.4	90.3	3.33	3.2
	9.0	4.7	10.9	975	41.6	27.5	1.22	45.8	34.2	1.3	26.8	2.24	19.2	95.5	3.51	3.9
	9.0	4.7	10.9	1200	41.9	29.8	1.27	46.2	32.9	1.2	26.6	2.32	18.7	90.5	3.36	3.3
40	4.5	1.5	3.5	975	40.4	26.5	1.53	45.6	26.5	2.2	29.2	2.46	20.8	97.7	3.48	4.2
	4.5	1.5	3.5	1200	40.7	28.5	1.60	46.1	25.5	2.1	29.6	2.37	21.5	92.8	3.65	3.6
	7.0	3.1	7.1	975	40.4	26.7	1.47	45.4	27.5	2.1	29.8	2.42	21.6	98.3	3.61	4.4
	7.0	3.1	7.1	1200	40.6	28.8	1.54	45.9	26.4	2.0	29.9	2.39	21.8	93.1	3.67	3.7
	9.0	4.6	10.6	975	40.4	26.9	1.41	45.2	28.5	1.9	30.4	2.38	22.3	98.9	3.75	4.5
	9.0	4.6	10.6	1200	40.6	29.0	1.48	45.6	27.5	1.9	30.3	2.41	22.1	93.4	3.69	3.9
50	4.5	1.5	3.4	975	38.9	26.0	1.73	44.8	22.5	3.2	32.8	2.53	24.2	101.1	3.80	4.8
	4.5	1.5	3.4	1200	39.2	27.9	1.81	45.4	21.7	3.1	33.2	2.44	24.9	95.6	3.99	4.2
	7.0	3.0	6.9	975	39.0	26.1	1.67	44.7	23.4	2.8	33.4	2.53	24.8	101.7	3.88	5.0
	7.0	3.0	6.9	1200	39.3	28.1	1.75	45.2	22.5	2.8	33.6	2.47	25.2	95.9	3.99	4.3
	9.0	4.4	10.2	975	39.1	26.2	1.61	44.6	24.3	2.4	34.1	2.52	25.5	102.3	3.96	5.2
	9.0	4.4	10.2	1200	39.3	28.3	1.68	45.0	23.4	2.6	34.0	2.49	25.5	96.2	4.00	4.5
60	4.5	1.4	3.3	975	36.9	25.7	1.90	43.3	19.4	3.9	36.2	2.65	27.2	104.4	4.01	5.5
	4.5	1.4	3.3	1200	37.4	28.2	1.98	44.1	18.9	3.9	36.9	2.54	28.2	98.4	4.25	4.7
	7.0	2.9	6.7	975	37.3	25.9	1.84	43.6	20.3	3.6	36.9	2.65	27.9	105.1	4.08	5.6
	7.0	2.9	6.7	1200	37.8	28.2	1.91	44.3	19.8	3.6	37.5	2.57	28.7	98.9	4.28	4.9
	9.0	4.3	9.9	975	37.7	26.2	1.78	43.8	21.2	3.2	37.7	2.66	28.6	105.8	4.15	5.8
	9.0	4.3	9.9	1200	38.2	28.3	1.85	44.5	20.7	3.3	38.2	2.59	29.3	99.4	4.32	5.1
70	4.5	1.4	3.2	975	34.8	25.4	2.07	41.9	16.8	4.7	39.6	2.76	30.2	107.6	4.20	6.1
	4.5	1.4	3.2	1200	35.5	28.4	2.15	42.8	16.5	4.7	40.5	2.64	31.5	101.3	4.49	5.3
	7.0	2.8	6.5	975	35.6	25.8	2.01	42.4	17.7	4.3	40.5	2.78	31.0	108.4	4.26	6.3
	7.0	2.8	6.5	1200	36.3	28.3	2.08	43.4	17.5	4.4	41.4	2.67	32.3	101.9	4.55	5.5
	9.0	4.1	9.6	975	36.3	26.2	1.96	43.0	18.6	3.9	41.3	2.80	31.7	109.2	4.32	6.5
	9.0	4.1	9.6	1200	37.1	28.2	2.01	44.0	18.5	4.1	42.3	2.69	33.1	102.6	4.61	5.7
80	4.5	1.3	3.1	975	33.5	24.5	2.30	41.4	14.6	5.4	43.2	2.86	33.4	111.0	4.42	6.8
	4.5	1.3	3.1	1200	34.2	27.4	2.39	42.3	14.3	5.5	44.2	2.74	34.8	104.1	4.72	5.8
	7.0	2.7	6.2	975	34.3	24.9	2.23	41.9	15.4	5.0	44.0	2.88	34.2	111.8	4.47	7.0
	7.0	2.7	6.2	1200	35.0	27.3	2.31	42.9	15.2	5.1	45.0	2.76	35.6	104.7	4.78	6.1
	9.0	4.0	9.3	975	35.0	25.2	2.17	42.4	16.1	4.6	44.8	2.90	34.9	112.6	4.53	7.3
	9.0	4.0	9.3	1200	35.8	27.2	2.23	43.4	16.0	4.8	45.9	2.79	36.4	105.4	4.83	6.3
90	4.5	1.3	3.0	975	32.3	23.6	2.52	40.9	12.8	6.1	46.7	2.97	36.6	114.4	4.61	7.5
	4.5	1.3	3.0	1200	32.9	26.4	2.62	41.9	12.6	6.3	47.8	2.84	38.1	106.9	4.93	6.3
	7.0	2.6	6.0	975	33.0	24.0	2.45	41.4	13.4	5.7	47.5	2.98	37.4	115.1	4.67	7.8
	7.0	2.6	6.0	1200	33.7	26.3	2.54	42.3	13.3	5.9	48.7	2.86	38.9	107.5	4.98	6.6
	9.0	3.9	8.9	975	33.7	24.3	2.38	41.8	14.1	5.4	48.3	3.00	38.1	115.9	4.72	8.1
	9.0	3.9	8.9	1200	34.4	26.2	2.45	42.8	14.0	5.5	49.5	2.88	39.7	108.2	5.04	6.9
100	4.5	1.3	2.9	975	30.3	23.7	2.83	39.9	10.7	6.9	Operation not recommended					
	4.5	1.3	2.9	1200	30.9	26.5	2.94	40.9	10.5	7.2						
	7.0	2.5	5.8	975	30.9	24.1	2.75	40.3	11.2	6.5						
	7.0	2.5	5.8	1200	31.6	26.4	2.85	41.3	11.1	6.7						
	9.0	3.7	8.6	975	31.6	24.4	2.67	40.7	11.8	6.1						
	9.0	3.7	8.6	1200	32.3	26.3	2.75	41.6	11.7	6.2						
110	4.5	1.2	2.8	975	28.2	23.9	3.14	38.9	9.0	7.7	Operation not recommended					
	4.5	1.2	2.8	1200	28.8	26.7	3.26	39.9	8.8	8.0						
	7.0	2.4	5.6	975	28.9	24.2	3.05	39.3	9.5	7.2						
	7.0	2.4	5.6	1200	29.5	26.6	3.16	40.2	9.3	7.5						
	9.0	3.6	8.3	975	29.5	24.6	2.97	39.6	9.9	6.8						
	9.0	3.6	8.3	1200	30.1	26.5	3.05	40.5	9.9	7.0						

Interpolation is permissible; extrapolation is not.
 All entering air conditions are 80°F DB and 67°F WB in cooling, and 70°F DB in heating.
 ARI/ISO certified conditions are 80.6°F DB and 66.2°F WB in cooling and 68°F DB in heating.
 Table does not reflect fan or pump power corrections for ARI/ISO conditions.
 All performance is based upon the lower voltage of dual voltage rated units.
 Operation below 40°F EWT is based upon a 15% antifreeze solution.
 Operation below 60°F EWT requires optional insulated water/refrigerant circuit (standard on residential models).
 See performance correction tables for operating conditions other than those listed above.
 For operation in the shaded areas, please see the Performance Data Selection Notes on Page 20.

Performance Data — 50YCS042 / 38WQS42 With GAH042

1150 CFM Nominal (Rated) Airflow Cooling, 1400 CFM Nominal (Rated) Airflow Heating

Performance capacities shown in thousands of Btuh

EWT °F	GPM	WPD		Cooling - EAT 80/67°F							Heating - EAT 70°F					
		PSI	FT	Airflow CFM	TC	SC	kW	HR	EER	HWC	HC	kW	HE	LAT	COP	HWC
20	10.5	6.2	14.3	Operation not recommended							26.5	2.62	17.5	91.3	2.96	3.6
	10.5	6.2	14.3								27.2	2.60	18.4	88.0	3.07	3.1
30	5.2	2.0	4.6	1150	50.5	33.1	1.67	56.2	30.3	1.6	31.3	2.71	22.0	95.2	3.38	4.1
	5.2	2.0	4.6	1400	52.4	36.4	1.73	58.3	30.3	1.3	31.3	2.65	22.3	90.7	3.46	3.5
	9.0	4.7	10.9	1150	49.9	32.6	1.62	55.4	30.9	1.6	31.4	2.71	22.2	95.3	3.40	4.3
	9.0	4.7	10.9	1400	52.5	36.6	1.68	58.2	31.3	1.4	31.9	2.67	22.8	91.1	3.51	3.6
	10.5	6.0	13.9	1150	49.3	32.2	1.57	54.6	31.4	1.7	31.6	2.71	22.4	95.4	3.42	4.4
	10.5	6.0	13.9	1400	52.6	36.9	1.63	58.2	32.4	1.5	32.5	2.68	23.3	91.5	3.55	3.8
40	5.2	1.9	4.5	1150	48.6	32.2	1.94	55.2	25.1	2.7	35.8	2.80	26.3	98.9	3.75	4.8
	5.2	1.9	4.5	1400	50.4	35.4	2.01	57.2	25.1	2.5	35.9	2.73	26.6	93.7	3.85	4.2
	9.0	4.6	10.6	1150	48.0	31.7	1.87	54.4	25.6	2.5	36.1	2.81	26.5	99.1	3.76	5.0
	9.0	4.6	10.6	1400	50.5	35.6	1.94	57.1	26.0	2.4	36.9	2.77	27.4	94.4	3.90	4.3
	10.5	5.8	13.5	1150	47.3	31.3	1.81	53.5	26.1	2.3	36.3	2.82	26.7	99.3	3.77	5.2
	10.5	5.8	13.5	1400	50.5	35.9	1.88	57.0	26.9	2.3	37.8	2.80	28.3	95.0	3.96	4.5
50	5.2	1.9	4.3	1150	46.7	31.3	2.21	54.2	21.1	3.8	40.4	2.88	30.6	102.5	4.11	5.6
	5.2	1.9	4.3	1400	48.4	34.3	2.29	56.2	21.1	3.6	40.4	2.82	30.8	96.7	4.21	4.8
	9.0	4.4	10.2	1150	46.0	30.8	2.13	53.3	21.6	3.4	40.7	2.91	30.8	102.8	4.10	5.8
	9.0	4.4	10.2	1400	48.4	34.6	2.21	56.0	21.9	3.4	41.8	2.87	32.0	97.7	4.27	5.0
	10.5	5.6	13.0	1150	45.4	30.4	2.05	52.4	22.1	2.9	41.1	2.94	31.1	103.1	4.10	6.0
	10.5	5.6	13.0	1400	48.5	34.9	2.13	55.8	22.8	3.1	43.2	2.92	33.2	98.6	4.34	5.2
60	5.2	1.8	4.2	1150	45.3	31.0	2.44	53.6	18.6	4.6	44.5	2.98	34.3	105.8	4.37	6.3
	5.2	1.8	4.2	1400	46.9	33.3	2.52	55.5	18.6	4.6	45.0	2.90	35.1	99.7	4.55	5.5
	9.0	4.3	9.9	1150	45.4	30.4	2.36	53.4	19.3	4.2	45.2	3.02	34.9	106.4	4.38	6.5
	9.0	4.3	9.9	1400	47.0	33.7	2.42	55.2	19.4	4.2	46.4	2.94	36.3	100.7	4.61	5.7
	10.5	5.5	12.6	1150	45.5	29.9	2.27	53.2	20.0	3.8	45.9	3.06	35.4	106.9	4.40	6.7
	10.5	5.5	12.6	1400	47.0	34.1	2.31	54.9	20.3	3.9	47.8	2.99	37.6	101.6	4.68	5.9
70	5.2	1.8	4.0	1150	43.9	30.8	2.67	53v	16.4	5.5	48.6	3.08	38.1	109.1	4.62	7.0
	5.2	1.8	4.0	1400	45.5	32.3	2.75	54.8	16.5	5.5	49.5	2.98	39.4	102.8	4.87	6.2
	9.0	4.1	9.6	1150	44.7	30.0	2.58	53.5	17.3	5.0	49.6	3.13	38.9	109.9	4.65	7.3
	9.0	4.1	9.6	1400	45.5	32.7	2.63	54.4	17.3	5.1	50.9	3.02	40.6	103.7	4.94	6.4
	10.5	5.3	12.2	1150	45.5	29.3	2.49	54.0	18.2	4.6	50.6	3.17	39.8	110.8	4.67	7.5
	10.5	5.3	12.2	1400	45.5	33.2	2.50	54.0	18.2	4.8	52.3	3.07	41.9	104.6	5.00	6.6
80	5.2	1.7	3.9	1150	41.7	29.8	2.97	51.8	14.0	6.3	53.0	3.16	42.2	112.7	4.91	7.9
	5.2	1.7	3.9	1400	43.2	31.2	3.06	53.6	14.1	6.4	54.1	3.06	43.6	105.8	5.17	6.7
	9.0	4.0	9.3	1150	42.5	29.1	2.87	52.3	14.8	5.8	54.3	3.23	43.2	113.7	4.92	8.1
	9.0	4.0	9.3	1400	43.2	31.7	2.92	53.2	14.8	6.0	55.7	3.13	45.1	106.9	5.22	7.0
	10.5	5.1	11.8	1150	43.2	28.4	2.77	52.7	15.6	5.4	55.5	3.30	44.2	114.7	4.93	8.4
	10.5	5.1	11.8	1400	43.2	32.2	2.78	52.7	15.6	5.6	57.4	3.19	46.5	108.0	5.27	7.3
90	5.2	1.6	3.8	1150	39.5	28.8	3.27	50.7	12.1	7.1	57.5	3.25	46.4	116.3	5.19	8.7
	5.2	1.6	3.8	1400	40.9	30.2	3.37	52.4	12.1	7.4	58.6	3.15	47.9	108.8	5.46	7.3
	9.0	3.9	8.9	1150	40.2	28.1	3.16	51.0	12.7	6.7	58.9	3.34	47.5	117.5	5.17	9.0
	9.0	3.9	8.9	1400	40.9	30.7	3.21	51.9	12.7	6.9	60.5	3.23	49.5	110.0	5.49	7.7
	10.5	4.9	11.4	1150	41.0	27.4	3.05	51.4	13.4	6.3	60.4	3.43	48.7	118.6	5.16	9.4
	10.5	4.9	11.4	1400	40.9	31.1	3.06	51.4	13.4	6.4	62.5	3.31	51.2	111.3	5.53	8.0
100	5.2	1.6	3.6	1150	37.5	28.2	3.65	50.0	10.3	8.0	Operation not recommended					
	5.2	1.6	3.6	1400	38.9	29.6	3.76	51.7	10.3	8.3						
	9.0	3.7	8.6	1150	38.2	27.6	3.53	50.3	10.8	7.5						
	9.0	3.7	8.6	1400	38.9	30.0	3.59	51.1	10.8	7.8						
	10.5	4.7	11.0	1150	38.9	26.9	3.41	50.6	11.4	7.1						
	10.5	4.7	11.0	1400	38.9	30.5	3.42	50.6	11.4	7.2						
110	5.2	1.5	3.5	1150	35.6	27.6	4.04	49.4	8.8	8.9	Operation not recommended					
	5.2	1.5	3.5	1400	36.8	29.0	4.16	51.0	8.8	9.2						
	9.0	3.6	8.3	1150	36.2	27.0	3.91	49.6	9.3	8.4						
	9.0	3.6	8.3	1400	36.8	29.4	3.97	50.4	9.3	8.6						
	10.5	4.6	10.5	1150	36.9	26.3	3.77	49.7	9.8	7.9						
	10.5	4.6	10.5	1400	36.9	29.9	3.78	49.8	9.8	8.1						

Interpolation is permissible; extrapolation is not.

All entering air conditions are 80°F DB and 67°F WB in cooling, and 70°F DB in heating.

ARI/ISO certified conditions are 80.6°F DB and 66.2°F WB in cooling and 68°F DB in heating.

Table does not reflect fan or pump power corrections for ARI/ISO conditions.

All performance is based upon the lower voltage of dual voltage rated units.

Operation below 40°F EWT is based upon a 15% antifreeze solution.

Operation below 60°F EWT requires optional insulated water/refrigerant circuit (standard on residential models).

See performance correction tables for operating conditions other than those listed above.

For operation in the shaded areas, please see the Performance Data Selection Notes on Page 20.

GT-GS & GT-S (50YCS) & (38WQS) Series

Performance Data — 50YCS048 / 38WQS48 With GAH048

1300 CFM Nominal (Rated) Airflow Cooling, 1600 CFM Nominal (Rated) Airflow Heating

Performance capacities shown in thousands of Btuh

EWT °F	GPM	WPD		Cooling - EAT 80/67°F							Heating - EAT 70°F					
		PSI	FT	Airflow CFM	TC	SC	kW	HR	EER	HWC	HC	kW	HE	LAT	COP	HWC
20	12.0	7.6	17.6	Operation not recommended							30.1	3.01	19.8	91.4	2.93	4.2
	12.0	7.6	17.6								31.4	2.95	21.3	88.2	3.12	3.6
30	6.0	2.5	5.8	1300	54.9	35.5	1.91	61.4	28.7	1.7	34.2	2.99	24.0	94.3	3.35	4.8
	6.0	2.5	5.8	1600	56.7	38.9	2.00	63.5	28.3	1.4	36.7	2.98	26.5	91.2	3.61	4.0
	9.0	4.7	10.9	1300	54.9	35.7	1.84	61.1	29.9	1.7	34.8	3.04	24.4	94.8	3.35	5.0
	9.0	4.7	10.9	1600	56.5	38.7	1.93	63.1	29.4	1.5	36.8	3.01	26.5	91.3	3.58	4.2
	12.0	7.4	17.1	1300	54.8	35.9	1.76	60.9	31.1	1.8	35.4	3.10	24.8	95.2	3.35	5.1
	12.0	7.4	17.1	1600	56.4	38.5	1.85	62.7	30.5	1.6	36.9	3.04	26.5	91.4	3.56	4.4
40	6.0	2.4	5.6	1300	53.4	34.9	2.19	60.9	24.4	3.0	37.9	3.07	27.4	97.0	3.61	5.6
	6.0	2.4	5.6	1600	55.1	38.2	2.30	63.0	24.0	2.8	40.7	3.07	30.2	93.6	3.89	4.8
	9.0	4.6	10.6	1300	53.3	35.1	2.11	60.5	25.3	2.8	39.1	3.13	28.4	97.8	3.66	5.8
	9.0	4.6	10.6	1600	54.9	38.0	2.21	62.4	24.9	2.6	41.3	3.09	30.7	93.9	3.92	5.0
	12.0	7.2	16.6	1300	53.2	35.2	2.03	60.1	26.3	2.6	40.3	3.19	29.4	98.7	3.71	6.0
	12.0	7.2	16.6	1600	54.7	37.8	2.12	61.9	25.8	2.5	41.9	3.11	31.3	94.2	3.95	5.2
50	6.0	2.3	5.4	1300	51.9	34.2	2.47	60.3	21.0	4.3	41.6	3.16	30.8	99.6	3.86	6.4
	6.0	2.3	5.4	1600	53.6	37.5	2.59	62.4	20.7	4.1	44.7	3.15	33.9	95.9	4.15	5.6
	9.0	4.4	10.2	1300	51.7	34.4	2.38	59.9	21.8	3.8	43.4	3.21	32.4	100.9	3.95	6.7
	9.0	4.4	10.2	1600	53.3	37.3	2.49	61.8	21.4	3.8	45.8	3.16	35.0	96.5	4.24	5.8
	12.0	7.0	16.1	1300	51.6	34.6	2.29	59.4	22.6	3.3	45.2	3.27	34.0	102.2	4.05	6.9
	12.0	7.0	16.1	1600	53.0	37.1	2.40	61.2	22.1	3.5	46.8	3.17	36.0	97.1	4.33	6.0
60	6.0	2.3	5.2	1300	50.1	33.6	2.71	59.4	18.5	5.3	46.9	3.26	35.8	103.4	4.21	7.3
	6.0	2.3	5.2	1600	52.7	37.2	2.83	62.4	18.6	5.2	48.7	3.24	37.6	98.2	4.40	6.3
	9.0	4.3	9.9	1300	50.1	33.6	2.62	59.1	19.2	4.8	48.5	3.31	37.2	104.5	4.29	7.5
	9.0	4.3	9.9	1600	52.4	37.0	2.73	61.7	19.2	4.8	50.3	3.25	39.2	99.1	4.53	6.6
	12.0	6.7	15.6	1300	50.1	33.6	2.52	58.8	19.9	4.3	50.1	3.36	38.6	105.7	4.37	7.7
	12.0	6.7	15.6	1600	52.0	36.9	2.62	60.9	19.8	4.5	52.0	3.27	40.8	100.1	4.66	6.8
70	6.0	2.2	5.1	1300	48.4	32.9	2.96	58.5	16.4	6.3	52.2	3.36	40.7	107.2	4.55	8.1
	6.0	2.2	5.1	1600	51.9	36.9	3.07	62.4	16.9	6.3	52.6	3.32	41.3	100.5	4.64	7.1
	9.0	4.1	9.6	1300	48.5	32.8	2.86	58.3	17.0	5.8	53.6	3.40	42.0	108.1	4.62	8.4
	9.0	4.1	9.6	1600	51.4	36.8	2.96	61.5	17.4	5.9	54.9	3.35	43.5	101.8	4.81	7.3
	12.0	6.5	15.1	1300	48.7	32.7	2.76	58.1	17.7	5.3	54.9	3.44	43.2	109.1	4.68	8.6
	12.0	6.5	15.1	1600	50.9	36.6	2.85	60.6	17.9	5.5	57.1	3.37	45.6	103.0	4.97	7.6
80	6.0	2.1	4.9	1300	46.6	32.1	3.26	57.7	14.3	7.2	56.1	3.45	44.3	110.0	4.77	9.0
	6.0	2.1	4.9	1600	50.0	36.0	3.39	61.5	14.7	7.4	56.6	3.41	45.0	102.8	4.87	7.8
	9.0	4.0	9.3	1300	46.7	32.0	3.15	57.5	14.8	6.7	57.2	3.48	45.4	110.8	4.82	9.4
	9.0	4.0	9.3	1600	49.5	35.8	3.26	60.6	15.2	6.9	58.6	3.43	47.0	103.9	5.01	8.1
	12.0	6.3	14.6	1300	46.9	31.9	3.04	57.2	15.4	6.3	58.4	3.52	46.4	111.6	4.86	9.7
	12.0	6.3	14.6	1600	49.0	35.7	3.14	59.7	15.6	6.4	60.7	3.44	48.9	105.1	5.16	8.4
90	6.0	2.0	4.7	1300	44.8	31.3	3.57	57.0	12.6	8.2	60.1	3.53	48.0	112.8	4.98	10.0
	6.0	2.0	4.7	1600	48.0	35.0	3.71	60.7	13.0	8.5	60.6	3.49	48.7	105.1	5.08	8.4
	9.0	3.9	8.9	1300	44.9	31.2	3.45	56.7	13.0	7.7	60.9	3.56	48.8	113.4	5.01	10.4
	9.0	3.9	8.9	1600	47.6	34.9	3.57	59.7	13.3	8.0	62.4	3.51	50.4	106.1	5.21	8.8
	12.0	6.1	14.0	1300	45.1	31.1	3.33	56.4	13.6	7.2	61.8	3.60	49.5	114.0	5.04	10.8
	12.0	6.1	14.0	1600	47.1	34.8	3.43	58.8	13.7	7.4	64.2	3.52	52.2	107.2	5.35	9.2
100	6.0	2.0	4.5	1300	43.1	30.9	3.99	56.7	10.8	9.3	Operation not recommended					
	6.0	2.0	4.5	1600	46.3	34.6	4.14	60.4	11.2	9.6						
	9.0	3.7	8.6	1300	43.3	30.8	3.85	56.4	11.2	8.7						
	9.0	3.7	8.6	1600	45.8	34.5	3.99	59.4	11.5	9.0						
	12.0	5.9	13.5	1300	43.4	30.7	3.72	56.1	11.7	8.2						
	12.0	5.9	13.5	1600	45.4	34.4	3.84	58.4	11.8	8.4						
110	6.0	1.9	4.4	1300	41.5	30.6	4.41	56.5	9.4	10.3	Operation not recommended					
	6.0	1.9	4.4	1600	44.5	34.2	4.58	60.1	9.7	10.7						
	9.0	3.6	8.3	1300	41.6	30.5	4.26	56.1	9.8	9.7						
	9.0	3.6	8.3	1600	44.1	34.1	4.41	59.1	10.0	10						
	12.0	5.6	13.0	1300	41.7	30.4	4.11	55.8	10.2	9.2						
	12.0	5.6	13.0	1600	43.6	34.0	4.24	58.1	10.3	9.4						

Interpolation is permissible; extrapolation is not.

All entering air conditions are 80°F DB and 67°F WB in cooling, and 70°F DB in heating.

ARI/ISO certified conditions are 80.6°F DB and 66.2°F WB in cooling and 68°F DB in heating.

Table does not reflect fan or pump power corrections for ARI/ISO conditions.

All performance is based upon the lower voltage of dual voltage rated units.

Operation below 40°F EWT is based upon a 15% antifreeze solution.

Operation below 60°F EWT requires optional insulated water/refrigerant circuit (standard on residential models).

See performance correction tables for operating conditions other than those listed above.

For operation in the shaded areas, please see the Performance Data Selection Notes on Page 20.

Performance Data — 50YCS060 / 38WQS60 With GAH060

1650 CFM Nominal (Rated) Airflow Cooling, 2000 CFM Nominal (Rated) Airflow Heating

Performance capacities shown in thousands of Btuh

EWT °F	GPM	WPD		Cooling - EAT 80/67°F							Heating - EAT 70°F					
		PSI	FT	Airflow CFM	TC	SC	kW	HR	EER	HWC	HC	kW	HE	LAT	COP	HWC
20	15.0	5.1	11.8	Operation not recommended							41.1	4.04	27.3	93.0	2.98	5.3
	15.0	5.1	11.8	Operation not recommended							41.5	3.99	27.9	89.2	3.05	4.5
30	7.5	1.6	3.6	1650	67.5	44.2	2.64	76.5	25.5	2.2	43.1	4.09	29.2	94.2	3.09	6.0
	7.5	1.6	3.6	2000	69.1	47.2	2.73	78.5	25.3	1.8	43.8	4.05	30.0	90.3	3.17	5.0
	11.3	3.1	7.1	1650	67.6	43.9	2.58	76.4	26.2	2.3	45.5	4.13	31.4	95.5	3.23	6.2
	11.3	3.1	7.1	2000	68.8	46.7	2.68	77.9	25.7	1.9	46.1	4.09	32.2	91.4	3.30	5.3
	15.0	4.9	11.4	1650	67.6	43.6	2.52	76.2	26.9	2.3	47.9	4.18	33.6	96.9	3.36	6.4
	15.0	4.9	11.4	2000	68.4	46.1	2.63	77.4	26.0	2.0	48.5	4.13	34.4	92.4	3.44	5.5
40	7.5	1.5	3.5	1650	65.3	43.5	3.05	75.7	21.4	3.8	50.4	4.29	35.8	98.3	3.45	7.0
	7.5	1.5	3.5	2000	66.8	46.5	3.15	77.6	21.2	3.5	51.3	4.25	36.8	93.7	3.54	6.0
	11.3	3.0	6.9	1650	65.4	43.3	2.96	75.5	22.1	3.5	53.0	4.35	38.2	99.8	3.57	7.3
	11.3	3.0	6.9	2000	66.5	46.0	3.07	77.0	21.7	3.4	53.3	4.28	38.7	94.7	3.65	6.2
	15.0	4.8	11.1	1650	65.5	43.0	2.86	75.2	22.9	3.2	55.7	4.42	40.6	101.3	3.69	7.5
	15.0	4.8	11.1	2000	66.3	45.5	2.99	76.5	22.1	3.2	55.3	4.32	40.6	95.6	3.75	6.5
50	7.5	1.5	3.4	1650	63.1	42.9	3.46	74.9	18.2	5.4	57.7	4.48	42.4	102.4	3.77	8.0
	7.5	1.5	3.4	2000	64.6	45.8	3.58	76.8	18.1	5.2	58.7	4.44	43.5	97.2	3.87	7.0
	11.3	2.9	6.7	1650	63.2	42.6	3.34	74.6	18.9	4.8	60.6	4.57	45.0	104.0	3.88	8.3
	11.3	2.9	6.7	2000	64.3	45.3	3.47	76.1	18.6	4.8	60.4	4.48	45.2	98.0	3.96	7.2
	15.0	4.6	10.7	1650	63.3	42.4	3.21	74.2	19.7	4.1	63.5	4.66	47.6	105.6	3.99	8.6
	15.0	4.6	10.7	2000	64.1	44.8	3.36	75.5	19.1	4.4	62.2	4.51	46.8	98.8	4.04	7.5
60	7.5	1.4	3.3	1650	61.6	41.9	3.78	74.6	16.3	6.6	64.9	4.68	48.9	106.4	4.06	9.1
	7.5	1.4	3.3	2000	63.1	45.4	3.90	76.4	16.2	6.5	66.1	4.64	50.3	100.6	4.17	7.9
	11.3	2.8	6.5	1650	61.9	41.7	3.61	74.2	17.1	6.0	68.1	4.79	51.7	108.2	4.16	9.4
	11.3	2.8	6.5	2000	63.2	45.0	3.74	75.9	16.9	6.1	68.5	4.67	52.6	101.7	4.30	8.2
	15.0	4.5	10.4	1650	62.1	41.4	3.45	73.9	18.0	5.4	71.3	4.90	54.5	110.0	4.26	9.7
	15.0	4.5	10.4	2000	63.2	44.6	3.58	75.4	17.7	5.6	71.0	4.71	54.9	102.9	4.42	8.5
70	7.5	1.4	3.2	1650	60.2	41.0	4.11	74.2	14.7	7.8	72.2	4.88	55.5	110.5	4.33	10.1
	7.5	1.4	3.2	2000	61.7	45.0	4.23	76.1	14.6	7.9	73.5	4.83	57.0	104.0	4.45	8.9
	11.3	2.7	6.3	1650	60.6	40.7	3.89	73.9	15.6	7.2	75.6	5.01	58.5	112.4	4.42	10.4
	11.3	2.7	6.3	2000	62.0	44.7	4.02	75.7	15.4	7.3	76.6	4.87	60.0	105.5	4.61	9.2
	15.0	4.3	10.0	1650	61.0	40.4	3.68	73.5	16.6	6.6	79.0	5.15	61.5	114.4	4.50	10.8
	15.0	4.3	10.0	2000	62.4	44.3	3.80	75.4	16.4	6.8	79.7	4.90	63.0	106.9	4.77	9.5
80	7.5	1.3	3.1	1650	57.6	40.2	4.56	73.2	12.6	9.0	79.4	5.08	62.1	114.6	4.58	11.3
	7.5	1.3	3.1	2000	59.0	44.2	4.70	75.0	12.5	9.2	80.9	5.03	63.7	107.5	4.71	9.7
	11.3	2.6	6.1	1650	58.0	40.0	4.32	72.7	13.4	8.4	82.7	5.20	64.9	116.4	4.66	11.7
	11.3	2.6	6.1	2000	59.3	43.8	4.46	74.5	13.3	8.6	83.8	5.05	66.6	108.8	4.86	10.1
	15.0	4.2	9.7	1650	58.3	39.7	4.09	72.3	14.3	7.8	86.0	5.33	67.8	118.2	4.73	12.1
	15.0	4.2	9.7	2000	59.7	43.5	4.22	74.1	14.1	8.0	86.7	5.07	69.4	110.1	5.01	10.5
90	7.5	1.3	3.0	1650	55.0	39.5	5.02	72.1	11.0	10.2	86.7	5.28	68.7	118.7	4.81	12.5
	7.5	1.3	3.0	2000	56.3	43.4	5.17	73.9	10.9	10.6	88.3	5.23	70.5	110.9	4.95	10.5
	11.3	2.5	5.9	1650	55.3	39.2	4.76	71.5	11.6	9.6	89.8	5.39	71.4	120.4	4.88	13.0
	11.3	2.5	5.9	2000	56.6	43.0	4.90	73.3	11.5	9.9	91.0	5.24	73.1	112.1	5.09	11.0
	15.0	4.1	9.4	1650	55.6	39.0	4.49	71.0	12.4	9.0	92.9	5.51	74.1	122.1	4.94	13.5
	15.0	4.1	9.4	2000	56.9	42.7	4.64	72.8	12.3	9.2	93.7	5.25	75.8	113.4	5.23	11.5
100	7.5	1.2	2.9	1650	53.3	39.1	5.56	72.3	9.6	11.5	Operation not recommended					
	7.5	1.2	2.9	2000	54.6	42.9	5.72	74.1	9.5	11.9	Operation not recommended					
	11.3	2.4	5.6	1650	53.7	38.8	5.27	71.6	10.2	10.8	Operation not recommended					
	11.3	2.4	5.6	2000	54.9	42.6	5.43	73.5	10.1	11.2	Operation not recommended					
	15.0	3.9	9.0	1650	54.0	38.5	4.98	71.0	10.8	10.2	Operation not recommended					
	15.0	3.9	9.0	2000	55.3	42.2	5.14	72.8	10.7	10.4	Operation not recommended					
110	7.5	1.2	2.8	1650	51.7	38.6	6.10	72.5	8.5	12.8	Operation not recommended					
	7.5	1.2	2.8	2000	52.9	42.5	6.28	74.4	8.4	13.3	Operation not recommended					
	11.3	2.4	5.4	1650	52.0	38.4	5.78	71.8	9.0	12.1	Operation not recommended					
	11.3	2.4	5.4	2000	53.3	42.1	5.96	73.6	8.9	12.5	Operation not recommended					
	15.0	3.8	8.7	1650	52.4	38.1	5.46	71.0	9.6	11.4	Operation not recommended					
	15.0	3.8	8.7	2000	53.6	41.8	5.64	72.8	9.5	11.6	Operation not recommended					

Interpolation is permissible; extrapolation is not.

All entering air conditions are 80°F DB and 67°F WB in cooling, and 70°F DB in heating.

ARI/ISO certified conditions are 80.6°F DB and 66.2°F WB in cooling and 68°F DB in heating.

Table does not reflect fan or pump power corrections for ARI/ISO conditions.

All performance is based upon the lower voltage of dual voltage rated units.

Operation below 40°F EWT is based upon a 15% antifreeze solution.

Operation below 60°F EWT requires optional insulated water/refrigerant circuit (standard on residential models).

See performance correction tables for operating conditions other than those listed above.

For operation in the shaded areas, please see the Performance Data Selection Notes on Page 20.

Performance Data Selection Notes

For operation in the shaded area when water is used in lieu of an anti-freeze solution, the LWT (Leaving Water Temperature) must be calculated. Flow must be maintained to a level such that the LWT is maintained above 40°F [4.4°C] when the JW3 jumper is not clipped (see example below). This is due to the potential of the refrigerant temperature being as low as 32°F [0°C] with 40°F [4.4°C] LWT, which may lead to a nuisance cutout due to the activation of the Low Temperature Protection. JW3 should never be clipped for standard range equipment or systems without antifreeze.

Example:

At 50°F EWT (Entering Water Temperature) and 1.5 gpm/ton, a 3 ton unit has a HE of 22,500 Btuh. To calculate LWT, rearrange the formula for HE as follows:

HE = TD x GPM x 500, where HE = Heat of Extraction (Btuh); TD = temperature difference (EWT - LWT) and GPM = U.S. Gallons per Minute.

$$TD = HE / (GPM \times 500)$$

$$TD = 22,500 / (4.5 \times 500)$$

$$TD = 10^\circ F$$

$$LWT = EWT - TD$$

$$LWT = 50 - 10 = 40^\circ F$$

In this example, as long as the EWT does not fall below 50°F, the system will operate as designed. For EWTs below 50°F, higher flow rates will be required (open loop systems, for example, require at least 2 gpm/ton when EWT is below 50°F).

Performance capacities shown in thousands of Btuh

Heating - EAT 70°F						
HWC	HC	kW	HE	LAT	COP	HWC
	16	1.62	10.5	92.8	2.89	2.1
	16.2	1.59	10.8	88.7	2.99	1.8
0.9	18.9	1.69	13.2	97.0	3.29	2.4
0.8	19.2	1.62	13.7	92.3	3.48	2.0
1.0	19.1	1.69	13.4	97.2	3.32	2.5
0.8	19.4	1.64	13.8	92.4	3.47	2.1
1.0	19.3	1.69	13.5	97.5	3.35	2.6
0.8	19.5	1.65	13.9	92.6	3.47	2.2
1.6	21.5	1.75	15.6	100.7	3.60	2.8
1.4	21.9	1.69	16.1	95.3	3.80	2.4
1.5	21.9	1.77	15.9	101.2	3.63	2.9
1.4	22.2	1.70	16.3	95.6	3.81	2.5
1.3	22.3	1.78	16.2	101.8	3.67	3.0
1.3	22.5	1.72	16.6	96.0	3.82	2.6
2.2	24.1	1.82	17.9	104.4	3.88	3.2
2.1	24.5	1.75	18.5	98.3	4.10	2.8
2.0	24.7	1.85	18.4	105.2	3.92	3.3
2.0	24.9	1.77	18.9	98.9	4.13	2.9
1.7	25.3	1.87	18.9	106.1	3.96	3.4
	25.4	1.79	19.3	99.4	4.16	3.0
	26.6	1.90	20.1	107.9	4.09	3.6
	27.1	1.82	20.9	101.4	4.38	3.2
		1.93	20.9	109.1	4.16	3.7
		1.94	21.6	102.3	4.41	3.3
			21.7	111.7	4.16	3.8

GT-GS Indoor Split (50YCS) Series

Model	018	024	030	036	042	048	060
Compressor [1 Each]	Scroll						
Factory Charge R22 (oz) [kg]	70 [1.98]	74 [2.09]	108 [3.06]	117 [3.32]	122 [3.46]	130 [3.69]	136 [3.86]
Water Connection Size							
IPT (in)	1	1	1	1	1	1	1
HWG Connection Size							
IPT (in)	1	1	1	1	1	1	1
Line Set Connection Size							
Suction Line Sweat Connection (in.)	3/4	7/8	7/8	7/8	7/8	7/8	1-1/8
Liquid Line Sweat Connection (in.)	3/8	3/8	3/8	3/8	3/8	3/8	1/2
Weight - Operating, (lbs) [kg]	165 [75]	203 [92]	205 [93]	217 [98]	221 [100]	229 [104]	235 [107]
Weight - Packaged, (lbs) [kg]	180 [82]	218 [99]	220 [100]	232 [105]	236 [107]	244 [111]	250 [113]

All units have spring compressor mountings, TXV expansion devices, and 1/2" [12.2mm] & 3/4" [19.1mm] electrical knockouts.

GT-S Outdoor Split (38WQS) Series

Model	018	024	030	036	042	048	060
Compressor [1 Each]	Rotary	Scroll					
Factory Charge R22 (oz) [kg]	70 [1.98]	74 [2.10]	86 [2.52]	101 [2.86]	122 [3.46]	130 [3.69]	136 [3.86]
Water Connection Size							
EPT (in)	1-1/4						
Line Set Connection Size							
Suction Line Sweat Connection (in.)	3/4	3/4	7/8	7/8	7/8	7/8	1-1/8
Liquid Line Sweat Connection (in.)	3/8	3/8	3/8	3/8	3/8	3/8	1/2
Weight - Operating, (lbs) [kg]	165 [75]	203 [92]	205 [93]	217 [98]	221 [100]	229 [104]	235 [107]
Weight - Packaged, (lbs) [kg]	180 [82]	218 [99]	220 [100]	232 [105]	236 [107]	244 [111]	250 [113]

All units have spring compressor mountings, TXV expansion devices, weather resistant cabinet, and 1/2" [12.2mm] & 3/4" [19.1mm] electrical knockouts. Hot Water Generator with factory installed hot gas service ports.

Dimensions — GT-GS & GT-S Series

Indoor Split (50YCS) Series

Model		Overall Cabinet			Water Connections						Refrigerant Connection				Electrical Knockouts		
		A Width	B Height	C Depth	1 Water In/Out	2 HWG In/Out	D Water In	E Water Out	F HWG In	G HWG Out	3 Suction	4 Liquid	H	I	J	K	L
					Swivel												
018 -024	in	22.4	19.3	25.6	1"	1"	2.4	5.4	13.9	16.9	3/4"	3/8"	8.1	11.1	5.7	9.7	12.2
	cm	56.9	49.0	65.0			6.1	13.7	35.3	42.9			20.6	28.3	14.5	24.6	31.0
030 -036	in	22.4	19.3	25.6	1"	1"	2.4	5.4	13.9	16.9	7/8"	3/8"	8.1	11.1	5.7	9.7	12.2
	cm	56.9	49.0	65.0			6.1	13.7	35.3	42.9			20.6	28.3	14.5	24.6	31.0
042 -048	in	25.4	21.3	30.6	1"	1"	2.4	5.4	15.9	18.9	7/8"	3/8"	9.1	12.1	8.1	11.7	14.2
	cm	64.5	54.1	77.7			6.1	13.7	40.4	48.0			23.2	30.8	20.6	29.7	36.1
060	in	25.4	21.3	30.6	1"	1"	2.4	5.4	15.9	18.9	1-1/8"	1/2"	9.1	12.1	8.1	11.7	14.2
	cm	64.5	54.1	77.7			6.1	13.7	40.4	48.0			23.2	30.8	20.6	29.7	36.1

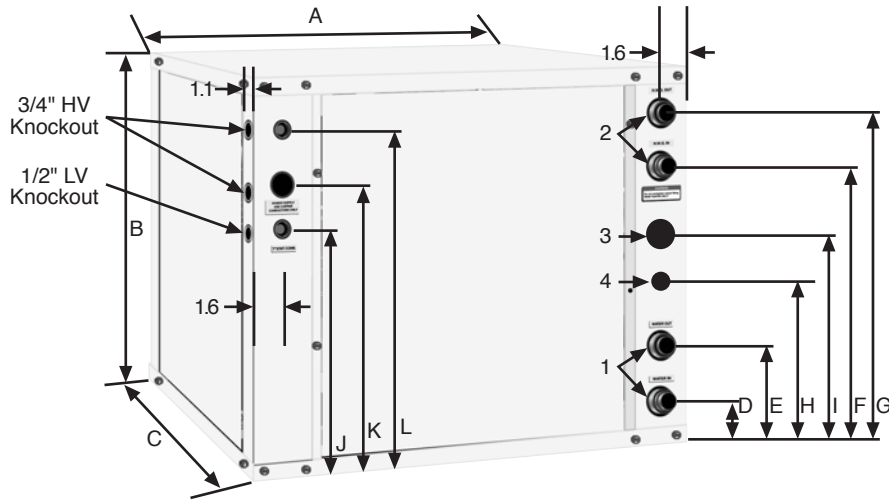

Outdoor Split (38WQS) Series

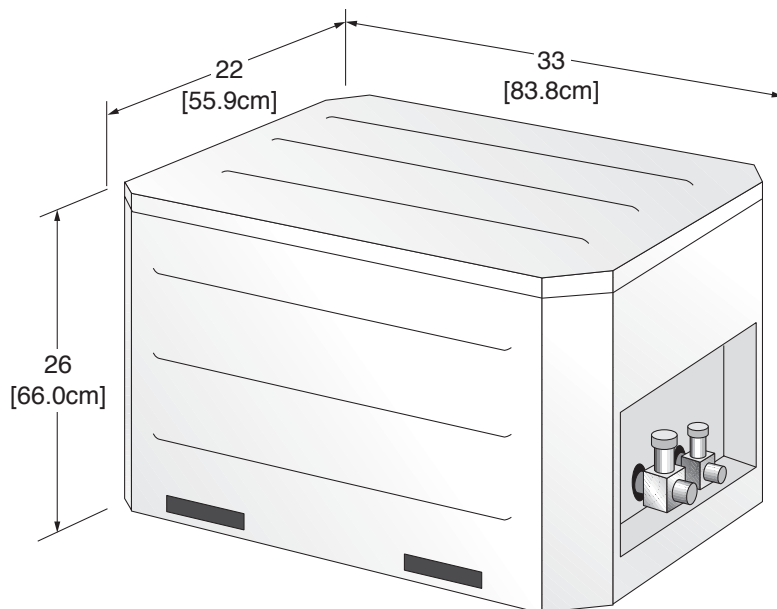

GT-GS Indoor Split (50YCS) Series Electrical Data

Model	Compressor			HWG Pump FLA	External Pump FLA	Total Unit FLA	Min Circuit Amps	Max Fuse/HACR	Min AWG	Max Wire Ft (m)
	RLA	LRA	Qty							
018	8.6	40.3	1	0.40	4.0	13.0	15.2	20	12	76 (23.3)
024	10.3	56.0	1	0.40	4.0	14.7	17.3	25	10	107 (32.7)
030	12.2	67.0	1	0.40	4.0	16.6	19.7	30	10	94 (28.7)
036	13.5	73.0	1	0.40	4.0	17.9	21.3	35	10	87 (26.5)
042	16.5	95.0	1	0.40	4.0	20.9	25.0	40	10	74 (22.6)
048	18.3	109.0	1	0.40	4.0	22.7	27.3	45	10	67 (20.7)
060	25.0	148.0	1	0.40	4.0	29.4	35.7	60	8	82 (25.2)

Rated Voltage of 208/230/60/1
HACR circuit breaker in USA only

Wire length based on one way measurement with 2% voltage drop

Min/Max Voltage of 197/254
All fuses Class RK-5

Wire size based on 60°C copper conductor and Minimum Circuit Ampacity.

GT-S Outdoor (38WQS) Series Electrical Data

Model	Compressor				HWG Pump FLA	Ext Loop Pump FLA	Total Unit FLA	Min Circuit Amps	Max Fuse/HACR	Min AWG	Max Wire Ft (m)
	RLA	LRA	Qty	Crank-case							
018	7.1	38.0	1	N/A	0.40	4.0	11.5	13.3	20	12	87 (26.6)
024	10.3	56.0	1	0.17	0.40	4.0	14.9	17.4	25	10	106 (32.5)
030	12.2	67.0	1	0.17	0.40	4.0	16.8	19.8	30	10	93 (28.6)
036	13.5	73.0	1	0.17	0.40	4.0	18.1	21.4	30	10	86 (26.4)
042	16.5	95.0	1	0.17	0.40	4.0	21.1	25.2	40	10	73 (22.4)
048	18.3	109.0	1	0.17	0.40	4.0	22.9	27.4	45	10	67 (20.6)
060	25.0	148.0	1	0.29	0.40	4.0	29.7	35.9	60	8	82 (25.1)

Rated Voltage of 208-230/60/1
HACR circuit breaker in USA only

Wire length based on one way measurement with 2% voltage drop

Min/Max Voltage of 197/254
All fuses Class RK-5

Wire size based on 60°C copper conductor and Minimum Circuit Ampacity.

GT-GS Indoor Split Electrical Wiring Diagram - 96B0001N02

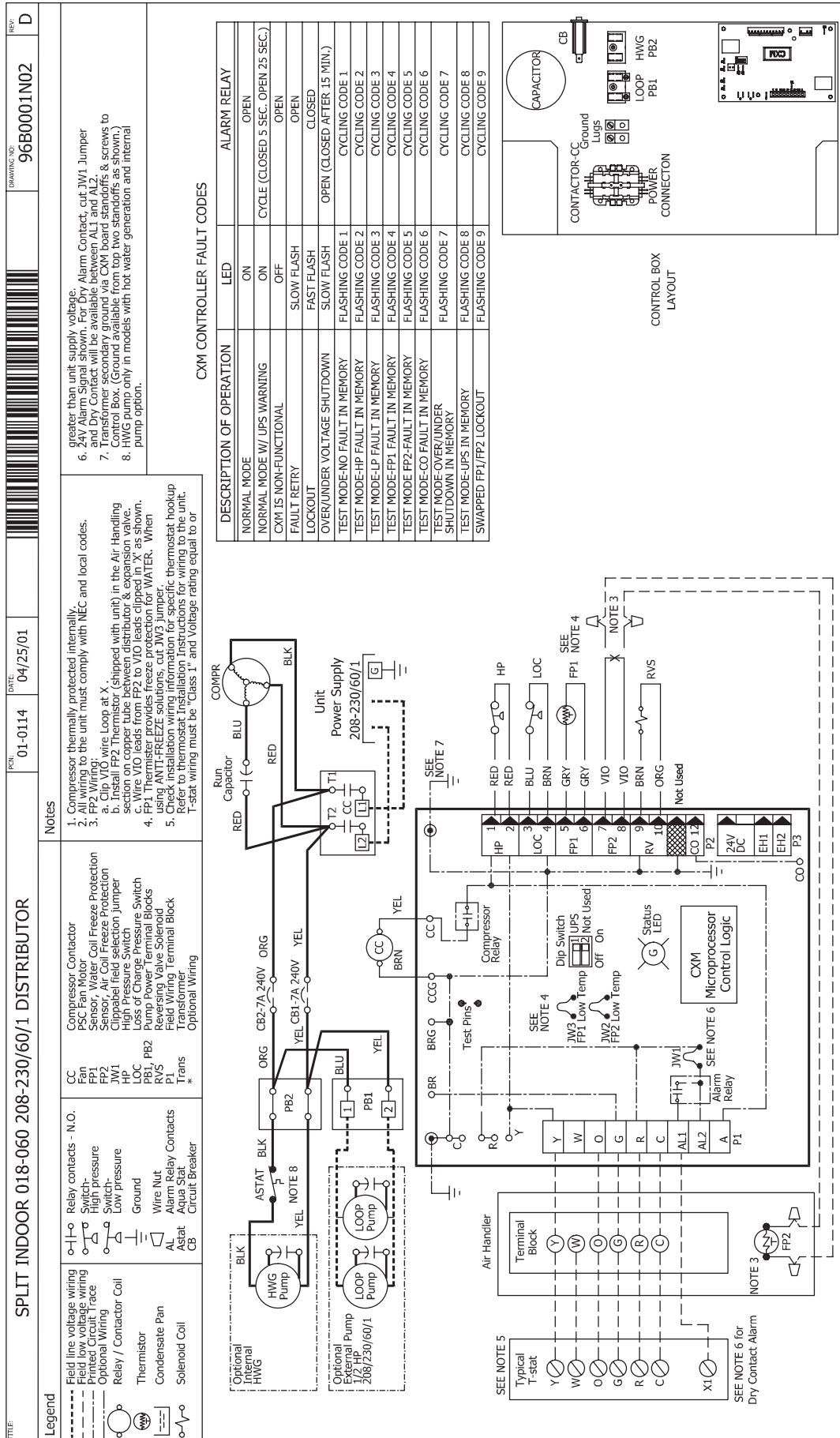

CXM CONTROLLER FAULT CODES

DESCRIPTION OF OPERATION	LED	ALARM RELAY
NORMAL MODE	ON	OPEN
NORMAL MODE W/ UPS WARNING	ON	CYCLE (CLOSED 5 SEC. OPEN 25 SEC.)
CXM IS NON-FUNCTIONAL	OFF	OPEN
FAULT RETRY	SLOW FLASH	CLOSED
OVER/UNDER VOLTAGE SHUTDOWN	FAST FLASH	OPEN (CLOSED AFTER 15 MIN.)
TEST MODE-NO FAULT IN MEMORY	SLOW FLASH	CYCLING CODE 1
TEST MODE-HP FAULT IN MEMORY	FLASHING CODE 2	CYCLING CODE 2
TEST MODE-LP FAULT IN MEMORY	FLASHING CODE 3	CYCLING CODE 3
TEST MODE-FP1 FAULT IN MEMORY	FLASHING CODE 4	CYCLING CODE 4
TEST MODE-FP2 FAULT IN MEMORY	FLASHING CODE 5	CYCLING CODE 5
TEST MODE-CO FAULT IN MEMORY	FLASHING CODE 6	CYCLING CODE 6
TEST MODE-OVER/UNDER SHUTDOWN IN MEMORY	FLASHING CODE 7	CYCLING CODE 7
TEST MODE-UPS IN MEMORY	FLASHING CODE 8	CYCLING CODE 8
SWAPPED FP1/FP2 LOCKOUT	FLASHING CODE 9	CYCLING CODE 9

CONTROL BOX LAYOUT

SEE NOTE 5

Typical T-stat

Y

W

O

G

R

C

X1

SEE NOTE 6 for Dry Contact Alarm

GT-S Outdoor Split Electrical Wiring Diagram - 69828103

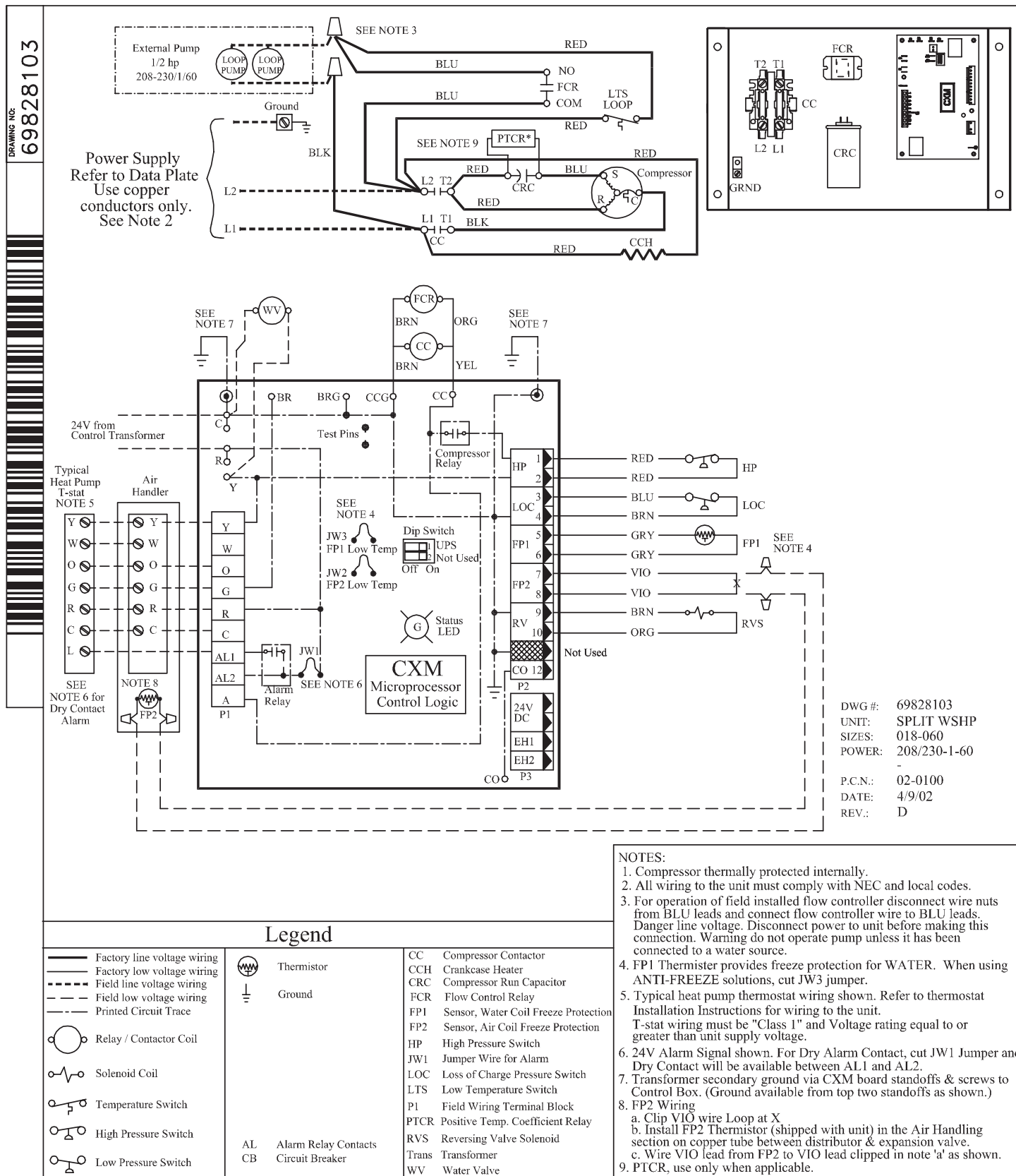

Equipment Selection

The installation of geothermal heat pump units and all associated components, parts, and accessories which make up the installation shall be in accordance with the regulations of ALL authorities having jurisdiction and MUST conform to all applicable codes. It is the responsibility of the installing contractor to determine and comply with ALL applicable codes and regulations.

General

Proper indoor coil selection is critical to system efficiency. Using an older-model coil can affect efficiency and may not provide the customer with rated or advertised EER and COP. Coil design and technology have dramatically improved operating efficiency and capacity in the past 20 years. Homeowners using an older coil are not reaping these cost savings and comfort benefits. **NEVER MATCH AN R-22 INDOOR COIL WITH AN R-410A COMPRESSOR SECTION.**

Newer indoor coils have a larger surface area, enhanced fin design, and grooved tubing. These features provide a larger area for heat transfer, improving efficiency and expanding capacity. Typical older coils may only have one-third to one-half the face area of these redesigned coils.

Indoor Coil Selection - R-22 Units

Geothermal split system heat pumps with R-22 refrigerant are rated in the ARI directory with a “generic” indoor coil match and PSC fan. Selection of air handlers that attain the published ARI ratings must meet or exceed the specifications listed in Table 1. **A TXV is required.** Cap tubes and fixed orifices are not acceptable.

Table 1: R-22 Air Handler Characteristics

Model*	Nominal Tons*	Evaporator Temp (°F)	CFM	Capacity (MBtuh)**
018	1.5	50	600	18.5 - 21.3
024	2.0	47	800	25.5 - 29.3
030	2.5	49	1000	31.5 - 36.2
036	3.0	48	1200	37.0 - 42.5
042	3.5	45	1400	42.2 - 48.5
048	4.0	46	1600	50.0 - 57.5
060	5.0	45	2000	58.0 - 66.7

* Nominal tons are at ARI/ISO 13256-1 GLHP conditions.

**When selecting an air handler based upon the above conditions, choose entering WB temperature of 67°F. Use evaporator temperature, CFM and capacity requirements as listed above. The air handler capacity must be at least at the minimum capacity shown in the table in order for the ARI rating condition to be valid. See Figure 1 for an example selection.

Air Handler Selection Example

Figure 1 shows a typical performance table for a heat pump air handler. Suppose the evaporator temperature required is 50°F, the capacity required is 35,000 Btuh and the airflow required is 1,200 CFM. Each evaporator temperature listed in the table shows three wet bulb temperatures. As recommended in the table notes above, select the 67°F WB column. At 1,200 CFM, the model 003 capacity is 36 MBtuh, which is higher than the minimum capacity required of 35,000 Btuh. In this example, model 003 would be the appropriate match.

Figure 1: Selecting Air Handler

UNIT SIZE	EVAPORATOR AIR CFM BF	COIL REFRIGERANT TEMPERATURE (°F)														
		35			40			45			50			55		
		Evaporator Air — Entering Wet-Bulb Temperature (°F)														
		72	67	62	72	67	62	72	67	62	72	67	62	72	67	62
003	800	59	48	38	53	42	32	46	35	24	39	27	20	30	18	16
	0.20	28	29	31	25	27	28	22	23	24	19	20	20	16	16	16
	1000	68	56	45	61	49	37	54	41	29	45	32	25	35	22	20
	0.22	32	34	37	29	31	33	26	28	28	23	24	25	19	20	20
	1200	75	62	49	68	54	42	60	45	34	50	36	29	40	25	23
	0.25	35	39	42	32	36	38	29	32	33	26	28	29	22	23	23
005	1400	80	67	54	73	59	46	64	49	38	54	39	32	43	28	27
	0.27	38	43	47	35	39	43	32	36	37	28	32	32	24	26	27
	750	61	49	39	55	43	33	48	37	27	41	29	20	33	21	17
	0.04	27	27	28	24	25	25	21	22	22	18	18	18	15	15	15
	950	74	60	48	67	53	40	59	45	33	50	35	25	39	24	21
	0.06	32	34	35	29	30	31	25	26	27	22	23	23	18	18	19
006	1150	89	72	57	79	63	48	69	52	38	58	41	31	44	29	25
	0.07	37	39	41	33	35	36	29	31	32	25	26	27	20	22	22
	1500	103	84	66	92	73	56	81	61	46	67	48	39	52	34	31
	0.10	43	46	49	36	41	44	34	37	39	29	32	33	25	27	27
	1700	110	89	71	99	78	60	86	65	49	72	51	42	56	37	35
	0.11	45	50	53	41	45	48	36	39	42	31	34	36	27	29	30
006	1050	77	62	50	69	55	43	61	47	35	52	38	27	41	27	22
	0.01	34	36	37	31	32	33	27	28	29	23	25	24	20	20	20
	1300	100	82	65	90	71	55	79	60	45	66	47	37	49	32	27
	0.02	42	45	47	37	40	42	33	35	37	29	31	32	23	25	24
	1750	117	96	77	106	84	65	93	71	53	78	56	46	60	40	34
	0.04	48	53	57	44	48	52	39	43	46	34	38	39	29	31	31
006	2050	126	103	83	114	91	71	99	76	59	84	60	50	65	44	39
	0.05	52	58	63	48	53	57	43	47	51	37	42	43	33	35	35
	2300	132	108	87	119	95	75	105	80	63	88	63	54	70	47	42
	0.06	55	62	68	50	57	61	45	51	54	40	45	46	35	39	38

= Gross cooling capacity (MBtuh)
 = Sensible heat capacity (MBtuh)
 BF = Bypass factor

Utilizing the Existing Air Handler or Coil (R22 units only)

It is recommended that a new coil or air handler be installed with any geothermal split system compressor section due to the low initial cost of the additional equipment versus the reliability and benefit of new technology, increased reliability and warranty. However, if the existing air handler must be used (R22 systems only), the following conditions apply:

- If the existing coil currently uses an orifice, the orifice must be removed and replaced with a TXV. If the coil utilizes capillary tubes, it will not operate properly with the geothermal split system and should be replaced.
- If life expectancy of indoor coil (and associated components - fan, cabinet, etc.) is less than 7-10 years, indoor section should be replaced.

Engineering Guide Specifications GT-GS Indoor Split

General

The liquid source heating/cooling split condensing units shall be ARI/ASHRAE/ISO 13256-1 loop performance certified and listed by a nationally recognized safety-testing laboratory or agency, such as Underwriter's Laboratory (UL), or Canadian Standards Association (CSA-US). Each unit shall be water run-tested at the factory. Each unit shall be pallet mounted and shipped in clear shrink wrap for visual shipping damage inspection. The units shall be warranted by the manufacturer against defects in materials and workmanship for a period of five years on all parts, and ten years on the compressor and refrigerant circuit parts with a service labor allowance during the first 30 days. An optional extended warranty is available for the GT-GS Indoor Split Series units, which adds a labor allowance and trip charge. The liquid source units shall be designed to operate with entering liquid temperature between 20°F and 110°F.

Casing & Cabinet

The cabinet shall be designed for indoor installations. The cabinet shall be fabricated from heavy-gauge galvanized steel painted with a epoxy powder coat paint with a 1000 hr. salt spray test rating. The interior shall be insulated with 1/2" thick, multi-density, coated glass fiber with edges sealed or tucked under flanges. Three compressor compartment access panels shall be provided and shall be removable with linesets and water piping in place. The internal component layout shall provide for major service with the unit in-place for restricted access installations.

Refrigerant Circuit

All units shall contain split refrigerant circuits employing a hermetically sealed compressor, thermal expansion valve, reversing valve, coaxial tube water-to-refrigerant heat exchanger, service ports, and backseating service valves. Compressors shall be high-efficiency advanced scroll type designed for heat pump duty and mounted on spring vibration isolators. Compressor motors shall be single phase PSC with internal overload protection. A factory installed bidirectional filter drier shall be provided. The coaxial water-to-refrigerant heat exchanger shall be designed for close approach temperatures and be constructed of a convoluted copper (optional cupronickel) inner tube and a steel outer tube. The thermal expansion valve shall provide proper superheat over the entire liquid temperature range with minimal "hunting". The valve shall operate only in the heating mode with the use of an internal check valve. The water-to-refrigerant heat exchanger and refrigerant suction lines shall be insulated to prevent condensation at low liquid temperatures. Air coil connections shall be made through brass backseating service valves with built-in Schrader ports.

Electrical

CXM Control - A microprocessor-based compressor controller (CXM) shall be provided to monitor and control unit operation. The control shall provide high and low pressure monitoring, field selectable water and air coil low water temperature sensing, over/under voltage monitoring. The control shall also provide for water valve connection, a test mode, short cycle protection, random start-up, as well as fault LED, fault memory, and intelligent fault retry.

The control shall employ quick attach harness assemblies for low voltage connections to the control board to aid in troubleshooting or replacement. An integral terminal block with screw terminals shall be provided on the control for all field low voltage connections. Line voltage lugs shall be provided for unit wiring. Units shall have knockouts for entrance of low and line voltage wiring. The control box shall be harness plug-connected for easy removal.

Piping

Supply and return water connections shall be 1" swivel fittings. All water piping shall be insulated to prevent condensation at low liquid temperatures.

Engineering Guide Specifications GT-S Outdoor Split

General

The liquid source heating/cooling split condensing units shall be ARI/ASHRAE/ISO 13256-1 loop performance certified and listed by a nationally recognized safety-testing laboratory or agency, such as Underwriter's Laboratory (UL), or Canadian Standards Association (CSA-US). Each unit shall be water run-tested at the factory. Each unit shall be pallet mounted and shipped in clear shrink wrap for visual shipping damage inspection. The units shall be warranted by the manufacturer against defects in materials and workmanship for a period of five years on all parts, and ten years on the compressor and refrigerant circuit parts with a service labor allowance during the first 30 days. An optional extended warranty is available for the GT-S Outdoor Split Series units, which adds a labor allowance and trip charge. The liquid source units shall be designed to operate with entering liquid temperature between 20°F and 110°F.

Casing & Cabinet

The cabinet shall be weather resistant and designed for outdoor installations. The cabinet shall be fabricated from heavy-gauge galvanized steel painted with a epoxy powder coat paint with a 1000 hr. salt spray test rating. The interior shall be insulated with 1/2" thick, multi-density, coated glass fiber with edges sealed or tucked under flanges. Two compressor compartment access panels shall be provided and shall be removable with linesets and water piping in place. The internal component layout shall provide for major service with the unit in-place for restricted access installations. The cabinet shall provide adequate space to house the one or two pump Flow Controller pumping module within the cabinet.

Refrigerant Circuit

All units shall contain split refrigerant circuits employing a hermetically sealed compressor, thermal expansion valve, reversing valve, coaxial tube water-to-refrigerant heat exchanger, service ports, and backseating service valves. Compressors shall be high-efficiency advanced scroll or rotary type designed for heat pump duty and mounted on vibration isolators. Compressor motors shall be single phase PSC with internal overload protection. A factory installed bidirectional filter drier shall be provided. The coaxial water-to-refrigerant heat exchanger shall be designed for close approach temperatures and be constructed of a convoluted copper (optional cupronickel) inner tube and a steel outer tube. The thermal expansion valve shall provide proper superheat over the entire liquid temperature range with minimal "hunting". The valve shall operate only in the heating mode with the use of an internal check valve. The water-to-refrigerant heat exchanger and refrigerant suction lines shall be insulated to prevent condensation at low liquid temperatures. Air coil connections shall be made through brass backseating service valves with built-in Schrader ports. Hot Water Generator (desuperheater) connections shall be accomplished with 1/2" backseating service valves.

Electrical

CXM Control - A microprocessor-based compressor controller (CXM) shall be provided to monitor and control unit operation. The control shall provide high and low pressure monitoring, field selectable low water temperature sensing, over/under voltage monitoring. The control shall also provide for water valve connection, a test mode, short cycle protection, random start-up, as well as fault LED, fault memory, and intelligent fault retry.

The control shall employ quick attach harness assemblies for low voltage connections to the control board to aid in troubleshooting or replacement. An integral terminal block with screw terminals shall be provided on the control for all field low voltage connections. Line voltage lugs shall be provided for unit wiring. Units shall have knockouts for entrance of low and line voltage wiring. The control box shall be harness plug-connected for easy removal.

Piping

Supply and return water connections shall be 1-1/4" MPT fittings. All water piping shall be insulated to prevent condensation at low liquid temperatures.

Accessories & Warranty

Accessories & Options

Hot Water Generator (internal) - 50YCS units only

An optional heat reclaiming desuperheater coil of vented double-wall copper construction suitable for potable water shall be provided. The coil and hot water circulating pump shall be factory mounted inside the unit. A high limit (50YCS units) temperature switch shall be provided to disable the pump when these conditions occur.

Hot Water Generator (field installed) - 38WQS units only

An optional heat reclaiming Hot Water Generator (desuperheater) Remote Module with vented double-wall copper construction suitable for potable water shall be provided as a field installed accessory. A high limit shut-off switch shall be provided. The HWG Remote Module shall be located remote from the compressor section, near the water heater, and shall include an internal pump and water coil.

Cupro-Nickel Heat Exchanger

An optional corrosion resistant CuNi coaxial heat exchanger shall be factory installed in lieu of standard copper construction.

Thermostat (field installed)

A multistage auto-changeover electronic digital thermostat shall be provided. The thermostat shall offer 2 heating and 1 cooling stages with precise temperature control. An OFF-HEAT-AUTO-COOL-EMERG system switch, OFF-AUTO fan switch, and indicating LED's shall be provided. The thermostat shall read out in °F or °C and be calibratable.

Flow Controller (field installed)

A self-contained module shall provide all fluid pumping, fill and connection requirements for ground-source closed loop systems up to 20 GPM. The Flow Controller shall provide 1" pump isolation valves and 3-way service valves. Pump heads shall be removable from the volute for easy replacement. The Flow Controller shall be enclosed in a polystyrene case and fully insulated with urethane foam to prevent condensation. The Flow Controller shall have a 5-year warranty on all parts.

Hose Kits (field installed) - 50YCS only

A rubber hose kit shall provide connections between the unit and Flow Controller. Rubber 1" hose allows flexible connection and absorbs vibration transmission between unit and Flow Controller. Brass elbows with MPT fittings for unit connection, barbed fittings for hose connection and FPT fittings for Pressure/Temperature ports shall be included to allow service and troubleshooting of the unit. Hose clamps shall be used to connect the hose to the brass elbows and Flow Controller.

Cooling TXV Kit (field installed)

A cooling thermostatic expansion valve kit shall be provided to be field installed on the A-Coil or at the air handler.

Warranty Information

The Carrier Geothermal residential warranty reflects the reliability built in to every unit and includes five years on all parts, and ten years on the compressor and refrigerant circuit parts with a service labor allowance during the first 30 days. An optional extended warranty is available for residential units, which adds a labor allowance and trip charge. See extended warranty certificate (CA186) for details.

Section Revision Log

Date	Page #	Description
10/01/06	All	First Published

