

Installation Instructions

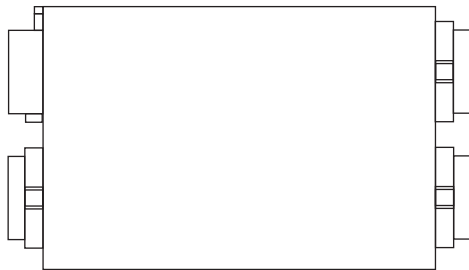

HRVCCLHA - Conventional Unit

A05260

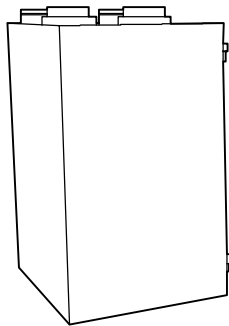

HRVCCLVU - High Efficiency Unit

A92377

NOTE: Read the entire instruction manual before starting the installation.

SAFETY CONSIDERATIONS

Improper installation, adjustment, alteration, service, maintenance, or use can cause explosion, fire, electrical shock, or other conditions which may cause death, personal injury or property damage. Consult a qualified installer, service agency or your distributor or branch for information or assistance. The qualified installer or agency must use factory-authorized kits or accessories when modifying this product. Refer to the individual instructions packaged with the kits or accessories when installing.

Follow all safety codes. Wear safety glasses, protective clothing, and work gloves. Have a fire extinguisher available. Read these instructions thoroughly and follow all warnings and cautions included in literature and attached to the unit. Consult local building codes and the current edition of the National Electrical Code (NEC) NFPA 70.

In Canada, refer to the current editions of the Canadian Electrical Code CSA C22.1.

Recognize safety information. When you see this symbol  on the unit and in instructions or manuals, be alert to the potential for personal injury. Understand the signal words **DANGER**, **WARNING**, and **CAUTION**. These words are used with the safety-alert symbol. **DANGER** identifies the most serious hazards, which **will** result in severe personal injury or death. **WARNING** signifies hazards, which **could** result in personal injury or death. **CAUTION** is used to identify unsafe practices, which **may** result in minor personal injury or product and property damage. **NOTE** is used to highlight suggestions which **will** result in enhanced installation, reliability, or operation.

INTRODUCTION

The Heat Recovery Ventilator (HRV) is used to exchange indoor stale air with outside fresh air. The HRV unit is equipped with a special heat recovery core which transfers sensible heat between the fresh incoming air and stale exhaust air.

It is required to locate the HRV in a conditioned space. Special attention should be given to condensate drain, duct application, balancing the HRV, and locating unit for easy access and routine maintenance. The cross-flow design core allows entering and leaving air streams to transfer heat energy without mixing.

LOCATION

Inspect Equipment

Move carton to final installation location. Remove the HRV from carton taking care not to damage unit. Remove all packaging and inspect unit for damage. Remove parts bag from inside unit. File claim with shipping company if shipment is damaged or incomplete.

COMPONENT DESCRIPTION

The following listed items are components of HRVCCLHA (see Fig. 1).

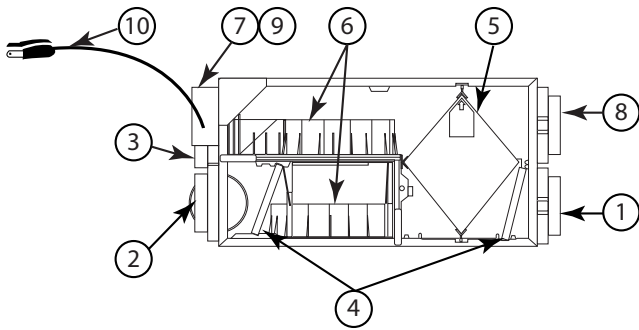

A05349

Fig. 1 - HRVCCLHA Conventional Horizontal Unit

1. Stale air return from building connected to return-air duct system.
2. Fresh-air intake connected to outdoor air inlet hood.
3. Exhaust-air connected to outdoor air exhaust hood.
4. Mechanical filters trap dust contained in the air.
5. Heat recovery core is a cross-flow type. The core transfers heat between the 2 air streams. See Fig. 2 and Fig. 3.



A05353

Fig. 2 - HRVCCLHA Airflow During Air Exchange

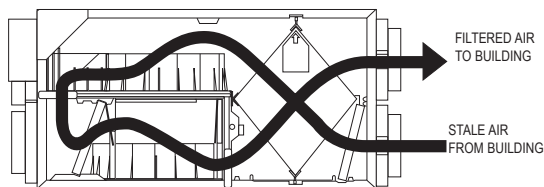

A05354

Fig. 3 - HRVCCLHA Airflow During Defrost

6. Blowers bring in fresh-air from outside and exhaust stale-air to outside.
7. Electronic control circuit ensures proper unit operation.
8. Fresh-air supply from HRV connected to return-air duct of forced-air system.

9. Terminal connector block for wiring wall and timer controls.

10. Electrical cord connects to standard 115V outlet.

The following listed items are components of HRVCCSVU and HRVCCLVU. See Fig. 4).

1. Stale-air return from building connected to return-air duct system.
2. Fresh-air intake connected to outdoor air inlet hood.
3. Exhaust-air connected to outdoor air exhaust hood.
4. Dampers are used to control air exchange with outdoor air during defrost mode.
5. Mechanical filters trap dust contained in the air.
6. Heat recovery core is either a cross-flow type for compact models, or a counter-flow type for high-efficiency models. The core transfers heat between the 2 air streams. See Fig. 5.
7. Blowers bring in fresh-air from outside and exhaust stale-air to outside.
8. Capacitor required for motor operation.
9. Condensation tray collects condensate from heat recovery core.
10. Drainage tubes connect to sleeved grommets.
11. Electronic control circuit ensures proper unit operation.
12. Fresh air supply from HRV connect to return-air duct of forced-air system.
13. Terminal connector block for wiring wall and timer controls.
14. Electrical cord connects to standard 115V outlet.

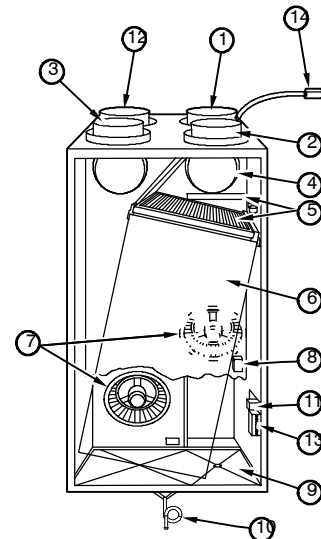

A98409

Fig. 4 - HRVCCLVU Compact High-Efficiency Unit

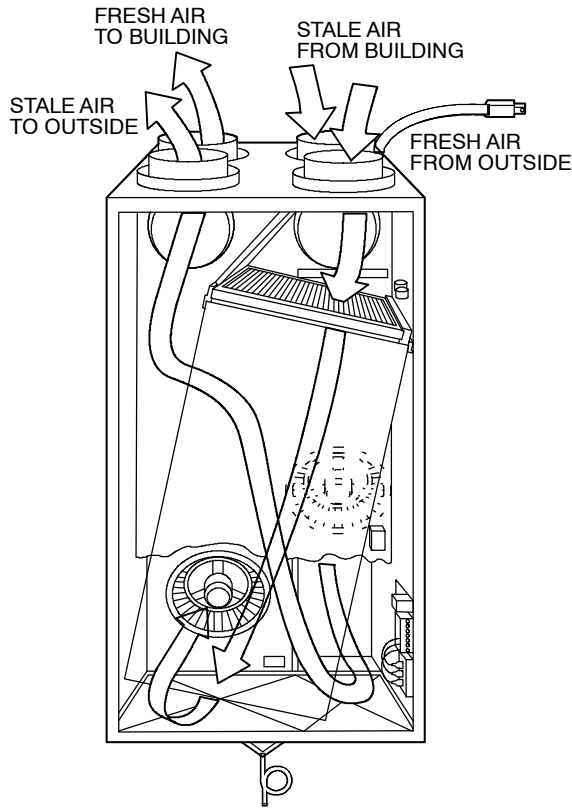

Fig. 5 - HRVCLVU Airflow During Air Exchange A92384

Select Location

The HRV **should be located in a conditioned space** and in close proximity to a fused power source. It should be easily accessible for routine maintenance.

If HRV is installed independent of a forced-air system, unit should be located near the center of the air distribution system. If HRV is installed in conjunction with a forced-air system, unit should be located next to (or close to) the indoor equipment.

UNIT INSTALLATION

⚠ CAUTION

UNIT DAMAGE HAZARD

Failure to follow this caution may result in equipment damage or improper operation.

Do not install HRV in a corrosive or contaminated atmosphere.

Mount Unit

The HRV can be suspended from floor joists using chains and 4 springs. Attach metal hanging bracket to all 4 sides of cabinet (see Fig. 6). Unit should always be installed as level as possible.

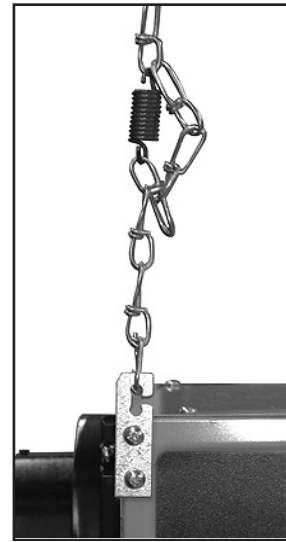

Fig. 6 - Chain Spring Installation A05331

HRV

Independent System Application

In the absence of a forced-air system and a typical duct system layout, the HRV can be applied as an independent or stand alone unit. To ensure comfort, this type of application involves running both fresh-air and return-air registers (or stale-air pickup registers) throughout the home.

⚠ WARNING

CARBON MONOXIDE POISONING HAZARD

Failure to follow this warning could result in personal injury or death.

Do not install return-air registers (or stale-air pickup registers) in same room as gas furnace or water heater.

Fresh-air registers are normally located in bedrooms, dining room, living room, and basement. It is recommended that registers be placed 6 to 12 in. (152 to 305 mm) from the ceiling on an interior wall and airflow directed toward ceiling. If registers are floor installed, airflow should be directed toward the wall.

Return-air (or stale-air pickup registers) are normally located to draw from kitchen, bathroom, basement, or other rooms where stale-air can exist.

Proper size and type of registers must be used to minimize pressure drop. The velocity of airflow through register should not be above 400 ft/minute.

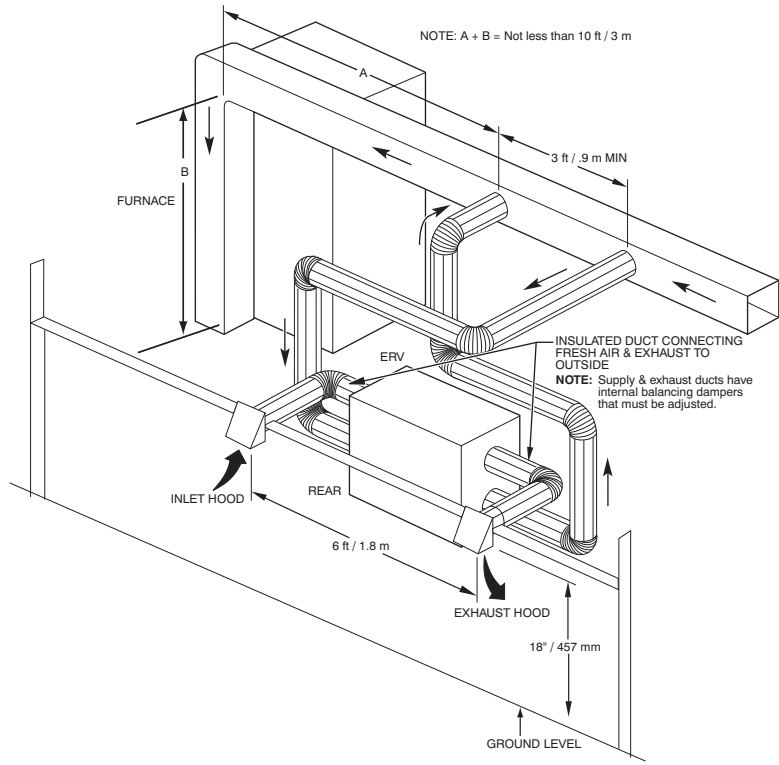

Fig. 7 - Exhaust Ventilation

A07282

Maximum length of duct for the system should be designed according to the highest speed of the unit. Refer to specifications listed in unit Product Data for ventilation capacities.

Forced-Air Application

Most HRV applications will be installed in conjunction with new or existing forced-air system. To operate properly, the fresh-air supply and stale-air return from HRV connect directly to return-air duct system. This is how the HRV distributes fresh air and removes stale air from inside of building (see Fig. 7). For these installations, furnace or fan coil blower must be interlocked and operate continuously whenever HRV is energized.

Interlock relay is now integrated into the control and is designed to interlock HRV with indoor equipment blower. When HRV is energized, R and G circuit inside of furnace or fan coil will energize.

NOTE: The fresh air from HRV is introduced into return-air duct at a point no less than 10 ft (3m) upstream of furnace or fan coil. This connection should be direct (see Fig. 7). This is to allow incoming fresh-air to mix before entering indoor equipment.

Connect Ducts to HRV

⚠ CAUTION

PROPERTY DAMAGE HAZARD

Failure to follow this caution may result in minor property damage from sweating duct or loss of unit efficiency and capacity.

If HRV duct work is installed in an unconditioned space, insulated flexible duct is required.

Insulated flexible duct is required on both fresh-air inlet and exhaust-air outlet ducts connecting to exterior wall. When using insulated flexible duct, the vapor barrier of the flexible ducts must be taped very tight to prevent condensation problems. To

reduce pressure drop, stretch the flex duct and support it in a proper manner to avoid reduced airflow.

When connecting the HRV to a return-air duct system, insulated flexible duct can be used. However, when metal or rigid ducts are applied use approximately 18-in. (457 mm) of flexible duct at HRV ports for fresh-air supply, and stale-air return. When using metal duct from fresh-air supply to system duct work, the metal duct should be insulated (see Fig. 8). This can act as a silencer when connecting ducts to return-air duct system. This should eliminate transmission of noise or vibration from unit to main duct system.

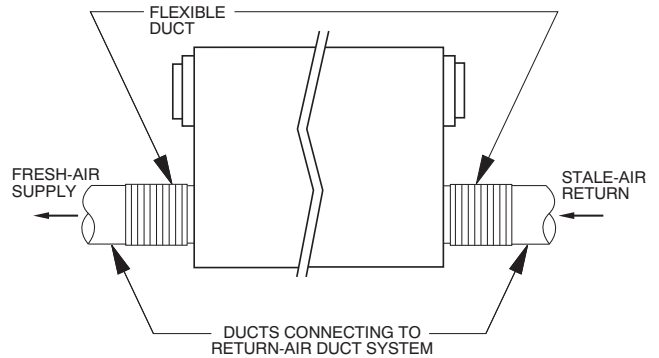

Fig. 8 - Flexible Duct Fit-Up

A98382

NOTE: Balancing dampers should be installed in stale-air exhaust and fresh air intake ducts before connecting to the HRVCLVU units. The balancing dampers are provided in the HRVCLHA units (see balancing HRV section). Make sure both balancing dampers are left in fully open position before connecting the ducts to these ports. See Integrated balancing damper illustration.

Condensate Drain

To connect condensate drain, proceed as follows:

1. Insert sleeved grommets into bottom of unit using the gasket washer and nut (see Fig. 9).
2. Cut two sections of plastic tubing, about 12-in. (305 mm) long and attach them to each drain.
3. Join the two short sections of plastic tubing to the “T” connector and the main tube as shown.
4. Make a loop in the tubing below the “T” connector to create a trap to prevent sewer gases from entering the ventilation system (see Fig. 9).
5. Connect unit drain to building’s main drain. Provide slight slope from unit for run-off.

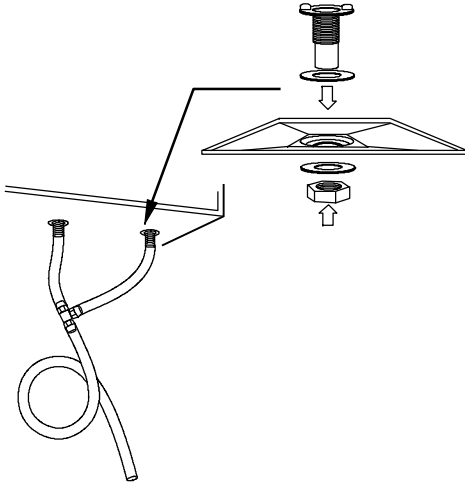

Fig. 9 - Condensate Drain With Loop Trap

A99268

Locate and Install Exterior Hoods

IMPORTANT: To prevent condensation problems, insulated flexible ducts are required on both fresh-air inlet and exhaust-air outlet ducts connecting between HRV and exterior wall.

Fresh-air intake and stale-air exhaust must be separated by at least 6 ft (1.8 m). Fresh-air intake must be positioned at least 10 ft. (3 m) from nearest dryer vent, furnace exhaust, driveway, gas meter, or oil fill pipe. Fresh-air intake must be positioned as far as possible from garbage containers and potential chemical fumes. When possible, it is advised to locate the intake and exhaust hoods on same side of house or building. The intake and exhaust hoods should never be located on interior corners or in dead air pockets (see Fig. 7). Both intake and exhaust hoods must be 18 in. (457 mm) from ground and at least 12 in. (305 mm) above anticipated snow level.

After selecting proper hood locations, make appropriate size hole through exterior wall, pass flexible duct through hole and insert hood tube into duct. Tape duct vapor barrier tightly around hood tube and insert assembly back into wall and fasten securely.

WALL CONTROL

Location

The HRV wall controls are unique to HRV and must be installed for proper unit operation.

Four wall control options are available:

1. Basic Control
2. OneTouch Control
3. Standard Control
4. Automatic Control

Basic Control Operation

The basic control contains a 3 position slide switch which is used to manually select OFF, LOW, and HIGH speed blower operation.

The unit operates continuously when LOW or HIGH is selected (see Table 1).

Table 1 – Basic Control

MODE	OPERATION	DAMPER POSITION	FAN SPEED
Off	Off	Closed to outside	Off
Low	Air exchange with outside	Open to outside	Low
High	Air exchange with outside	Open to outside	High

OneTouch Control Operation

Press “Push” until the desired ventilation operation is selected. There are three selections: High, Low, Intermittent. The power indicator light indicates which mode has been selected. See Table 2.

Table 2 – OneTouch Push Button Control

MODE	OPERATION	DAMPER POSITION	FAN SPEED
Off	Off	Closed to outside	Off
Low	Air exchange with outside	Open to outside	Low
Intermittent	Air exchange with outside	Open to outside	Low
High	Air exchange with outside	Open to outside	High

1. HIGH: This mode is recommended for the removal of excess pollutants and humidity. The ventilator will operate at its maximum speed continuously. The power indicator light will be lit red when this mode is selected.
2. LOW: This mode is recommended for normal daily operation. The ventilator will operate at minimum speed continuously. The power indicator light will be lit yellow when this mode is selected.
3. INTERMITTENT: This mode is recommended when the inside air is too dry in the heating season or too humid in the cooling season. The ventilator will operate at its minimum speed for 20 minutes per hour and be off for 40 minutes per hour. The power indicator light will be lit green when this mode is selected.
4. OFF: To turn the ventilator off, press “Push” until the power indicator light is turned off.

Standard Control Operation

The standard wall control has 3 basic modes of operation, OFF, LOW, and INTERMITTENT. Be sure that all modes of operation are fully functional. See Table 3 indicating standard control operation.

1. With switch off, ERV/HRV is inoperative and the LED is out.
2. With switch on LOW, ERV/HRV continuously exchanges air with outside. If control is satisfied, blower will run in low speed, otherwise, blower will run on high speed. The LED is illuminated all the time.
3. With switch on INTERMITTENT, the ERV/HRV exchanges air with outside on high-speed blower, and unit shuts down when control is satisfied. The ON LED is illuminated all the time, and AIR EXCHANGE LED is illuminated only when unit is running. This mode is ideal for maintaining proper humidity levels when no one is home.

Automatic Control Operation

This control contains an adjustable dehumidistat and push button switch to cycle between 3 modes of operation. There are 5 LEDs to indicate mode of operation (see Table 4).

HRV

Table 3 – Standard Control

MODE	DEHUMIDISTAT POSITION	OPERATION	DAMPER POSITION	FAN SPEED	ON LED	AIR EXCHANGE LED
Off	Any	Off	Closed to outside	Off	Off	Off
Low	Satisfied	Air exchange with outside	Open to outside	Low	On	On
	Call for dehumidification			High		On
Intermittent	Satisfied	Off	Closed to outside	Off		Off
	Call for dehumidification	Air exchange with outside	Open to outside	High		On

Table 4 – Automatic Control

MODE	DEHUMIDISTAT POSITION	OPERATION	DAMPER POSITION	FAN SPEED	INDICATOR LEDs
Off	Any	Off	Closed to outside	Off	Off
Intermittent	Satisfied	Off	Closed to outside	Off	Intermittent ON
	Call for dehumidification	Air exchange with outside	Open to outside	High	Intermittent and Exchange ON
Continuous	Satisfied			Low	Continuous and Exchange ON
	Call for dehumidification			High	
Recirculation	Satisfied			Recirculation	Closed to outside
	Call for dehumidification	Air exchange with outside	Open to outside	High	Recirculation and Exchange ON
Maintenance (open door)	Any	Off	Closed to outside	Off	Maintenance

HRV

NOTE: This control is designed to be used primarily with installations which are independent of a forced air system.

- Initially the switch is off. All LEDs are off and HRV is inoperative
- First push of mode button puts HRV into intermittent mode. The HRV operates at high speed when there is a call for dehumidification. Intermittent and exchange LEDs are illuminated. When dehumidistat is satisfied, HRV shuts down and exchange LED goes out.
- Next push of mode button puts system in continuous mode. Continuous and exchange LEDs remain on. The HRV operates at high-speed blower during calls for dehumidification and low-speed when dehumidistat is satisfied.
- Next push of mode button and exchange puts system in circulation mode. HRV operates in high speed at all times. Circulation LED remains on. When there is a call for dehumidification, exchange LED is on and HRV exchanges air with outside. When dehumidistat is satisfied, HRV dampers close which recirculates indoor air. The exchange LED goes off.
- The maintenance light illuminates every 3 months to indicate filter should be cleaned. It is reset by opening the door to the HRV.

NOTE: The standard and automatic controls sense humidity not temperature. Either control must be located in an area where it will continually monitor fresh air circulating within the home. Install HRV wall control as close as possible to main system thermostat and follow same guidelines as installing a thermostat, (locate approximately 5 ft. (1.5 m) above floor, mount on an inside partitioning wall, etc.).

NOTE: The HRV may be controlled using the Infinity System Control. The HRV may be connected using either a NIM or a 4-Zone Damper Module. See the appropriate instructions if using the NIM of a 4-Zone Damper Module for connection instructions. Blower interlock relay is not needed for use with the Infinity system control. The Infinity System Control will simultaneously control the HRV and the indoor blower.

Push Button Timers may be used and are connected to the HRV as shown in Fig. 10. However, the Infinity system should be set to continuous fan to ensure that the fresh air is circulated in the home. In a Zoned System, at least one zone should be set to continuous fan.

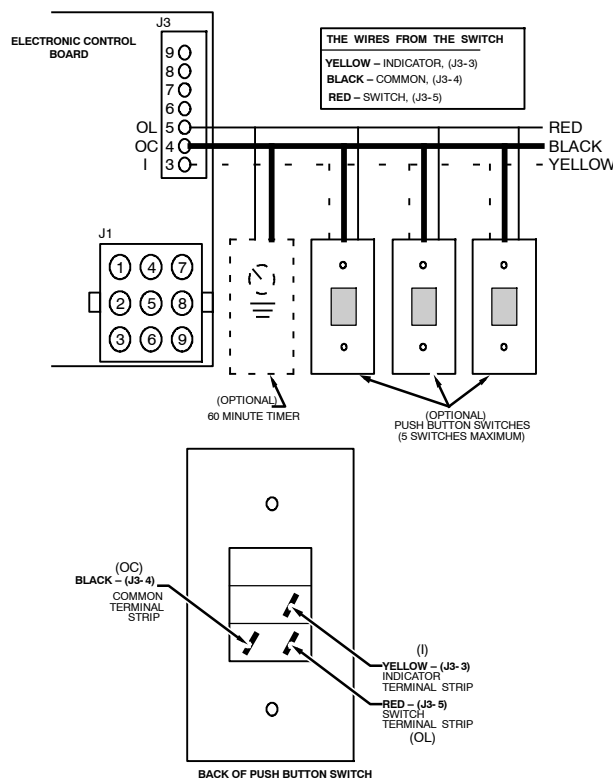

Fig. 10 - Push Button Timer Wiring Layout

A98386

OPERATING THE HRV WITH THE INFINITY CONTROL

The ventilator has four settings in heating mode and three settings in cooling mode.

Heating:

AUTO - the ventilator selects the speed based on indoor humidity and outdoor temperature. It may cycle on/off every 30 minutes depending on humidity and outside temperature.

LOW - low speed all of the time.

HIGH - high speed all of the time.

DEHUM - will only turn on if humidity is 3% over setpoint. The speed is determined by indoor humidity and outdoor temperature.

Cooling:

AUTO - the ventilator selects the speed based on indoor humidity and outdoor temperature. It may cycle on/off every 30 minutes depending on humidity and outside temperature.

LOW - low speed all of the time.

HIGH - high speed all of the time.

If the fan speed is set to Auto and the ventilator wants to run, the fan speed will run at High continuous speed. Otherwise, the fan will stay at the chosen continuous fan speed.

Wiring

Remove top cover assembly from wall control and pass thermostat wire through hole located on back of control before attaching to wall. Connect Y, R, G, and B (yellow, red, green and black) between wall control and HRV circuit board. Following color code (see Fig. 11 and Fig. 12). Replace top cover assembly.

NOTE: HRV wall control and circuit board operate on 12vdc.

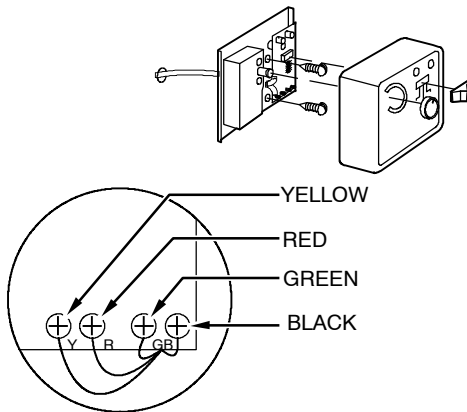

Fig. 11 - Typical Wall Control

A98383

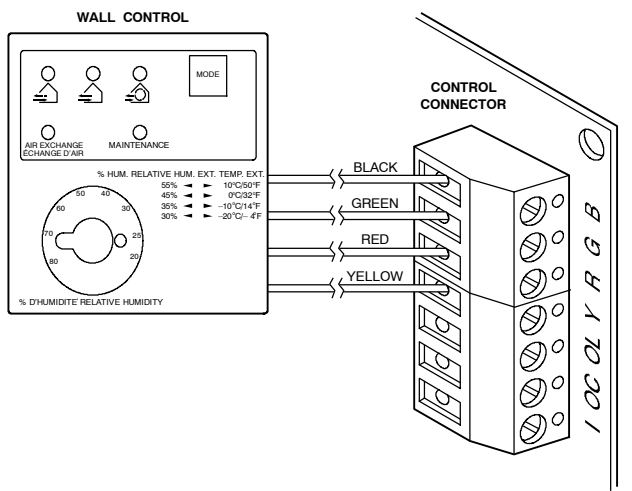

Fig. 12 - Control Connections

A98410

Humidity Selector

The humidity selector is a built-in dehumidistat designed to properly control the level of humidity in the house during the winter months. This control helps avoid condensation problems in upper northern regions where indoor humidity is a problem during the winter season.

NOTE: This control is not to be confused with a dehumidistat used during the summer months to control high relative indoor humidity.

Table 5 recommends humidity levels to avoid condensation.

Table 5 – Recommended Humidity Levels

OUTSIDE TEMPERATURE	DOUBLE-PANE WINDOWS	TRIPLE-PANE WINDOWS
50°F / 10°C	55%	65%
32°F / 0°C	45%	55%
14°F / -10°C	35%	45%
-4°F / -20°C	30%	45%
-22°F / -30°C	25%	35%

ELECTRICAL CONNECTIONS

115-VAC Wiring

The HRV operates on 115VAC. It comes with a power cord attached to unit and ready to plug into a fused outlet. Unit must be grounded for proper operation.

All electrical connections must comply with National and Local Electrical Codes, or other ordinances that might apply.

⚠ WARNING

ELECTRICAL SHOCK / FIRE HAZARD

Failure to follow this warning could result in property or unit damage.

Do not use an extension cord as a power source for operating the HRV.

HRV

12-vdc Wiring

The HRV circuit board, wall control, and accessories operate on 12vdc. See Wall Control section, item Wiring and Fig. 11 and Fig. 12 for more information.

ACCESSORIES

NOTE: Interlock relay is now integrated into the control.

The purpose of interlock relay is to energize indoor system equipment (furnace or fan coil) blower whenever HRV is calling. If HRV is energized, and indoor system equipment is not, interlock relay will energize and make R and G at indoor equipment. This will ensure fresh air distribution throughout the building via the central duct system.

20 Minute Timer

A push button timer can be used to override the wall control and put the HRV into high speed for 20 minutes. Connect switches in parallel and connect leads to HRV terminals I, OC, and OL (see Fig. 12). Push button locations are ideal in special activity areas, such as, bathroom, or kitchen, where high-speed exhaust operation is needed for a short period of time.

NOTE: The 20 minute timer will not function properly unless HRV wall control is applied and working correctly. Timing function is internal to electronic circuit board, it is activated by a momentary contact between OC and OL. The I connection is to illuminate the push button. The maximum number of push button timers that can be applied is 5.

60 Minute Adjustable Timer

A 60 minute adjustable timer can also be used to override wall control and put HRV into high-speed operation for a select amount of time. Connect timer in parallel with push button timers, or to HRV terminals OC and OL (see Fig. 12).

The 60 minute timer will provide a minimum of 10 minutes, and a maximum of 60 minutes of ventilation at high speed.

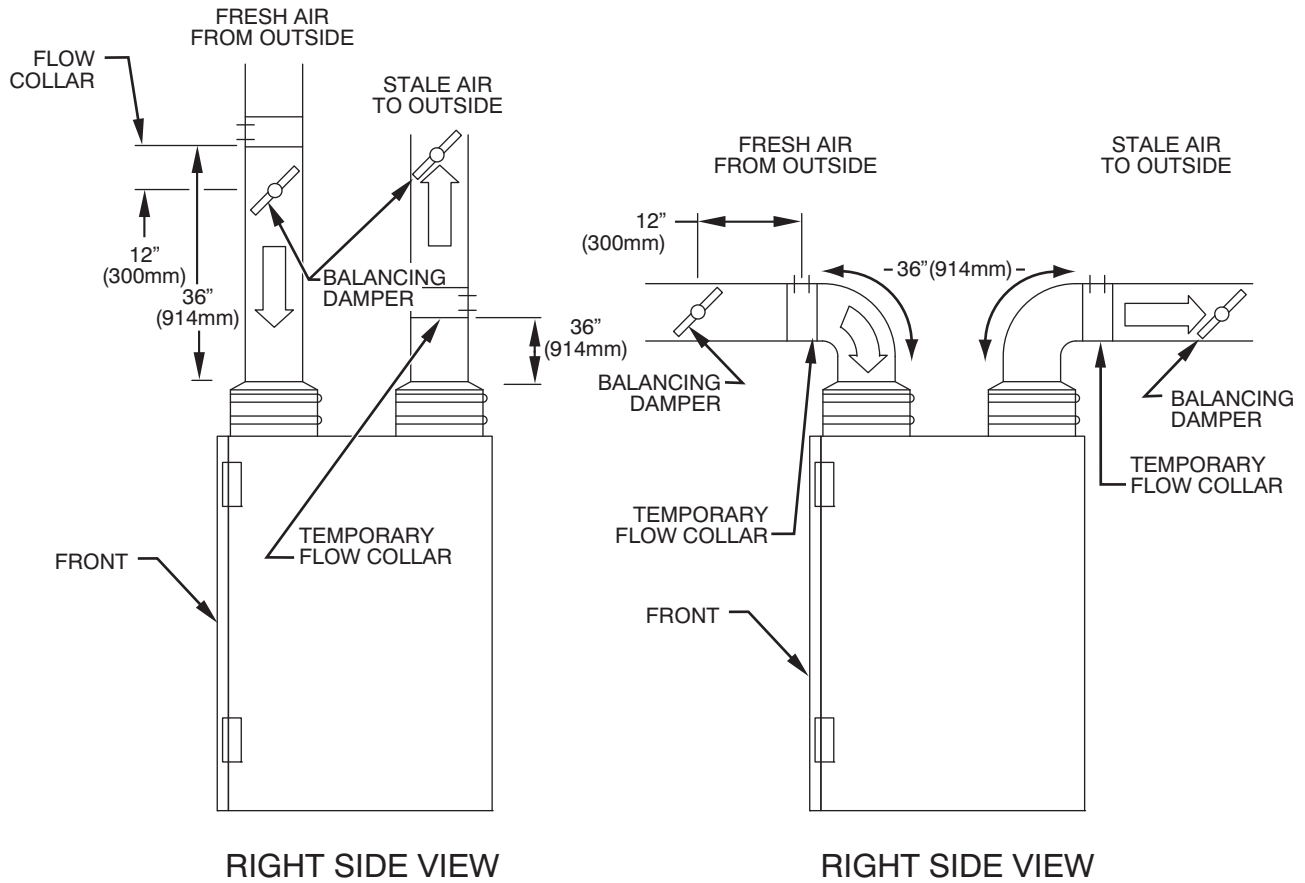

Fig. 13 - Balancing HRVCLVU

A10281

BALANCING HRV

Balancing intake and exhaust airflow is very important for proper system operation and optimum performance when applying an HRV. Unit balancing prevents a positive and/or negative pressure within the home. Balancing the HRV is done by applying temporary flow collars and permanent balancing dampers to the fresh air intake and stale air exhaust ducts (See Fig. 13).

NOTE: Temporary flow collars are not needed with the new HRVCLHA models since the air flow pressure taps are incorporated in the access door (see Fig. 14).

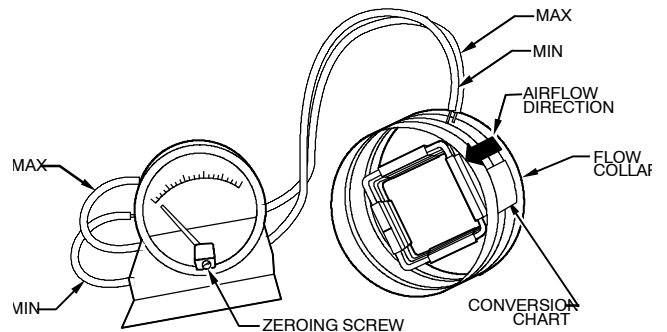

Fig. 15 - Magnehelic Gauge

A98400

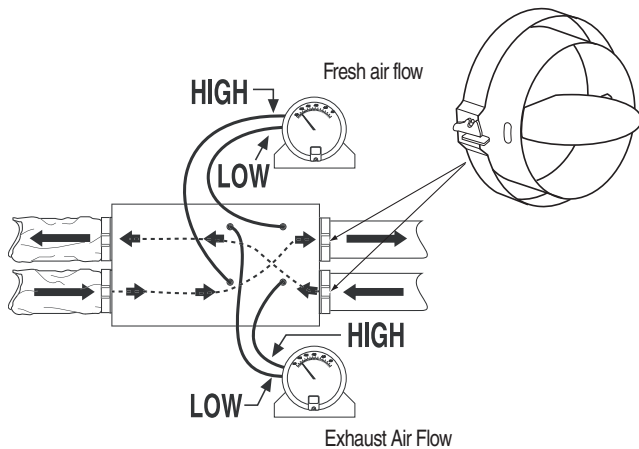

Fig. 14 - Balancing HRVCLHA

A05264

Airflow is determined by connecting a magnehelic gauge to the temporary flow collar (see Fig. 15). Both flow collars and magnehelic gauge are included in the accessory start-up balancing kit.

If supply-air from outside is greater than exhaust-air from the house, an imbalance can result over pressurizing the home. If exhaust-air is greater than supply-air, combustion appliances may backdraft, bringing exhaust fumes into the house. A balanced condition will ensure optimum performance, provide satisfied customers, and avoid expensive callbacks.

Before proceeding with balancing, all windows, doors, and fireplace flues should be tightly closed. No exhaust systems such as range top exhausts, dryer exhaust, fume hoods, bath or roof fans should be in operation. The forced-air furnace (if used for circulation) should be operating in continuous fan mode for normal operating speed.

Balancing Dampers

Balancing dampers (sometimes called butterfly dampers) are provided with the HRVCLHA. The dampers for the HRVCLVU are field supplied and should be permanently located in fresh-air intake and stale-air exhaust ducts between HRV and exterior wall (see Fig. 13 and Fig. 14). Some field modification may be required to ensure proper installation of balancing dampers

while located in flexible duct. Insulating over these dampers is strongly recommended after balancing is complete to prevent condensation problems.

Flow Collar

Flow collars are temporary and should be installed as close to HRV as possible and in straightest sections of duct to ensure accuracy (see Fig. 14). If only 1 flow collar is available, install collar in stale-air duct of HRV, and record airflow. Next, install collar in the fresh-air duct and record airflow. If 2 flow collars are available, it will be much easier to read airflow and properly adjust dampers to balance unit.

With speed control at maximum speed (high-speed operation) and continuous air exchange occurring with outside, connect hoses from flow collar to a magnehelic gauge (see Fig. 15). The gauge must be leveled and zeroed before use to read accurately. If needle falls below zero, reverse hose connections.

Measure exhaust air first, it is typically the lowest pressure due to nature of system and duct work. Next, measure fresh air. If fresh air reading is higher than exhaust reading, adjust damper until reading is same. If reading is lower, return to exhaust damper and adjust to obtain same reading. You can use label on flow collar to convert static pressure into airflow.

Once HRV is balanced and dampers are adjusted to equalize airflow, use tape or drive screws to prevent damper blades from moving. Remove flow collars and secure ducts. This procedure should be repeated to ensure unit is balanced properly.

NOTE: The flow collar directional arrow (on flow collar) must be oriented in the airflow direction of unit.

NOTE: Some field modification may be required to ensure proper temporary installation of flow collar during balancing when insulated flexible duct is used.

VENTILATION EVALUATION

⚠ CAUTION

UNIT DAMAGE HAZARD

Failure to follow this caution may result in reduced unit efficiency, capacity or unit life.

DO NOT use HRV during construction of a house or when sanding drywall. This type of dust may damage system.

When ventilation requirement is determined, use Product Data Sheets to reference unit airflow delivery and performance.

The ventilation capacity of an HRV unit while at maximum speed is defined according to greatest total airflow required. These methods are derived from the Canadian National Building Code 1995 version and the CSA F326.1 revision.

The following 2 methods can be used to evaluate the approximate ventilation needs of a house. Accuracy of calculations are dependent upon the information available and knowing critical measurements of the structure (see Fig. 16).

METHOD 1

To calculate approximate ventilation:

The sum of rooms X 10 CFM per room, plus 20 CFM for a master bedroom or basement.

Example: 11 rooms X 10 CFM + 2 X 20 CFM = 150 CFM.

NOTE: The master bedroom and basement are not included in first part of this equation, but figured in at second part of equation.

METHOD 2

To calculate approximate ventilation:

Referencing same example (see Fig. 16).

Total cu ft X 0.3 per hr = total. Take total and divide by 60 to get CFM.

Example:

1320 sq ft X 8 ft in height = 10560 cu ft per floor
 10560 cu ft x 3 floors = 31680 total cu ft in house
 31680 cu ft X 0.3 air change per hr = 9500 cu ft
 9500 cu ft ÷ 60 minimum per hr = 160 CFM.

Conclusion: The total amount of air flow needed is 160 CFM. This falls within airflow range of a HRVCCLHA1150 size unit.

HRV

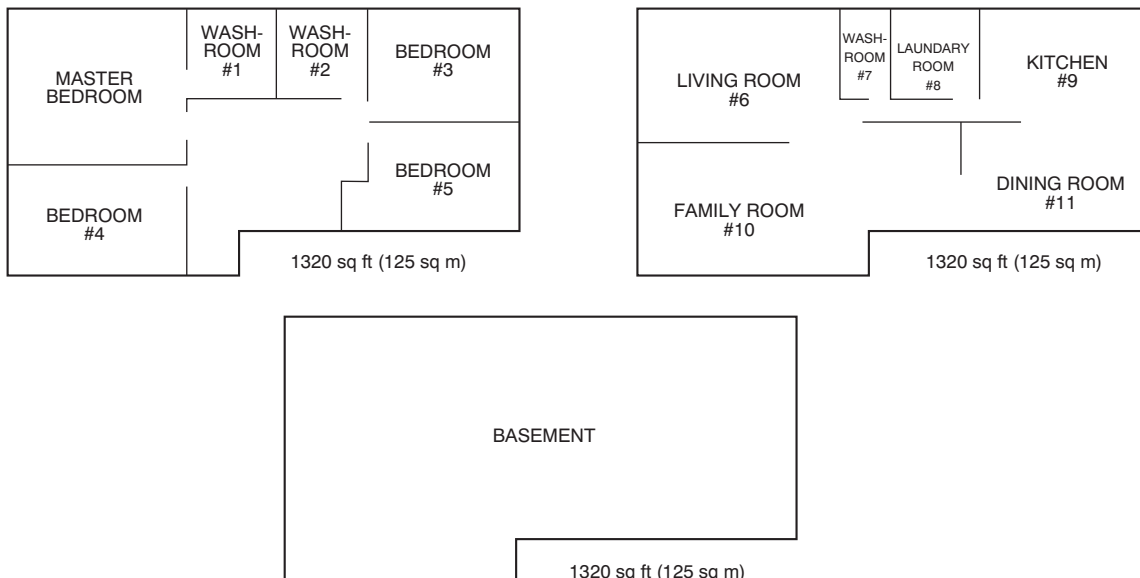

Fig. 16 - Floor Plan Example

A98388

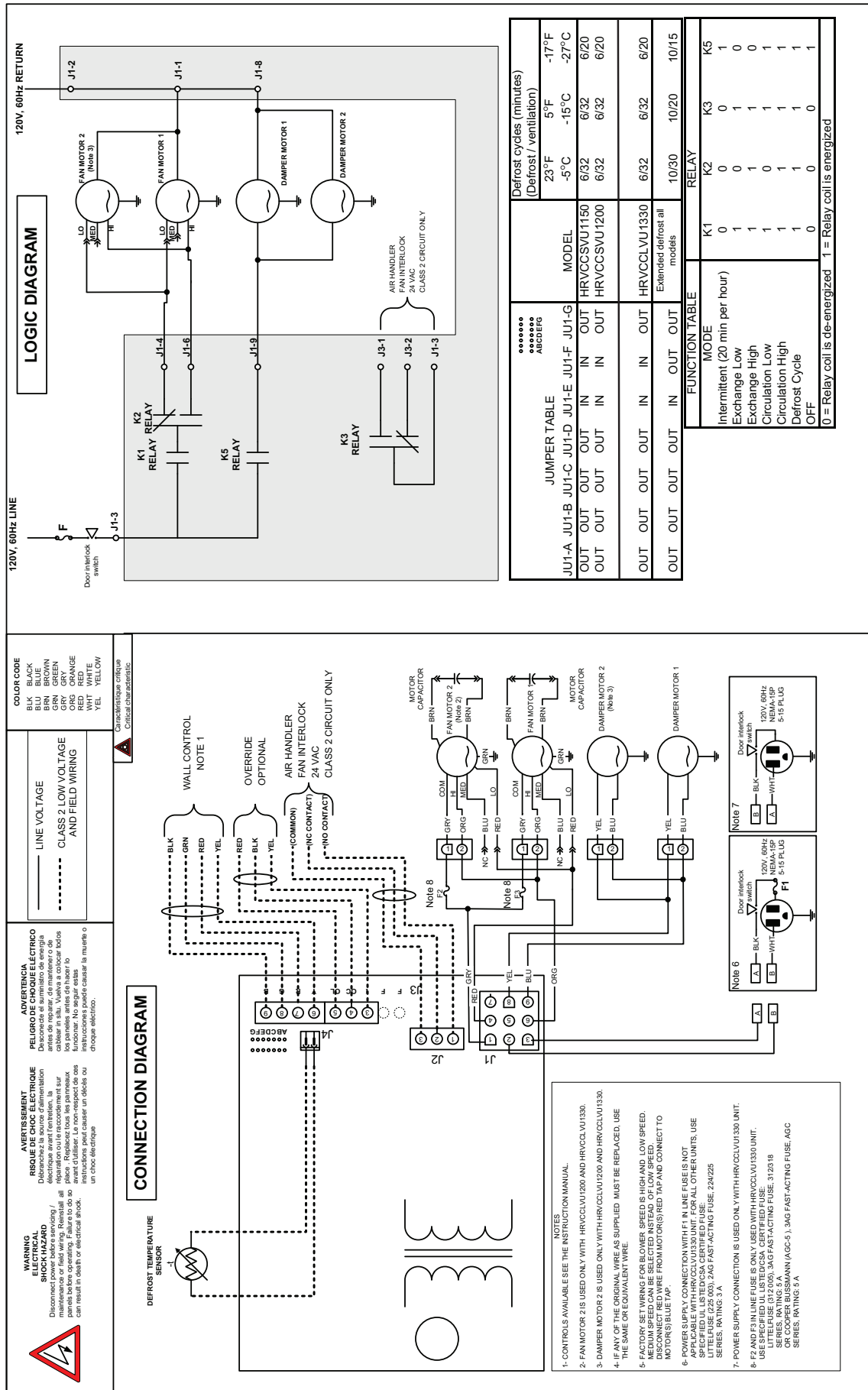

Fig. 18 - Wiring Diagram for Model: HRVCCLVU1330



CONTROL BOARD OPERATION

Board Function

NOTE: To ensure proper operation of HRV, configuration jumpers are located on electronic control board and must match configuration setup shown on Fig. 17 and Fig. 18 under Jumper Table.

Jumpers are factory set and do not require any changes unless control board is replaced. If control board is replaced, or you encounter unusual start-up operation, check jumpers to make sure they are located properly (see Fig. 17 and Fig. 18).

Defrost

The HRV continually monitors the outside air temperature. If the outside air is at or below 23°F (-5°C), the HRV will initiate a defrost cycle by closing the outside air damper and recirculating warm indoor air through the heat recovery core. This happens every 32 min. with 6 minute defrost cycle. During this process, core is defrosted without the use of electric strip heat. At 5°F (-15°C), unit will defrost for 6 minutes every 32 min. At -17°F (-27°C), the unit will sense a need to defrost every 20 minutes with a 6 minute cycle. See the Troubleshooting section for a control logic explanation. See Fig. 2 and Fig. 19.

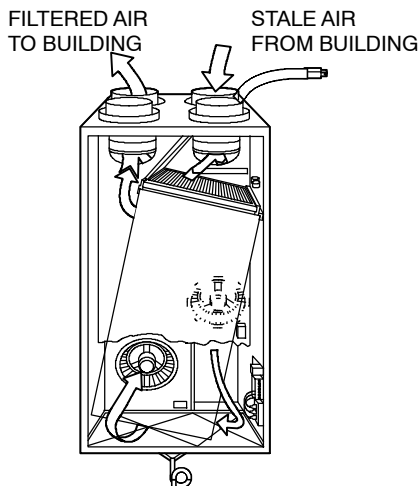

Fig. 19 - HRVCLVU Airflow During Recirculation and Defrost

A92385

Off and Intermittent/Off Mode

When HRV is Off, K1 relay is open, and K5 relay is energized which closes outside air damper (see Logic Diagram in Fig. 17 and Fig. 18).

High-Speed Air Exchange

When high-speed air exchange occurs, K1 and K2 relays are energized and K5 relay is de-energized. This opens low-speed contacts, and closes high-speed contact on K2 relay. This also opens contact on K5 relay which opens outside air damper. Then, 115VAC is applied between orange and gray wires on Molex plug (pins 1 and 6) and blower motor runs in high-speed operation (see Logic Diagram in Fig. 17 and Fig. 18).

Low-Speed Air Exchange

When low-speed air exchange occurs, K1 Relay is energized which closes the contacts. K2 and K5 relays are de-energized. This keeps low-speed contacts closed and high-speed contacts open on K2 relay, and opens outdoor air damper. 120VAC is applied between Red and Gray wires on Molex plug (pins 1 and 4) and blower motor runs in low-speed operation.

CARE AND MAINTENANCE

⚠ WARNING

ELECTRICAL SHOCK HAZARD

Failure to follow this warning could result in personal injury or death.

Before installing or servicing system, always turn off, tag and lockout main power to system. There may be more than 1 disconnect switch.

⚠ CAUTION

CUT HAZARD

Failure to follow this caution may result in personal injury.

Sheet metal parts may have sharp edges or burrs. Use care and wear appropriate protective clothing and gloves when handling parts.

Door

HRV door can be removed by unlatching brief case style latches, then slide door to the right and remove it from hinges. Door must be in place and secured shut for proper operation.

Filter

Filters in HRV are washable and should be cleaned every 3 months. Use a vacuum cleaner to remove heaviest portion of accumulated dust, then wash in lukewarm water. Allow filter to completely dry before reinstalling. A dirty air filter will cause excessive strain on blower motor. Never operate unit without a filter. Vacuum out debris.

In addition, regularly check and clean screens on exterior intake and exhaust hoods when necessary.

⚠ CAUTION

UNIT COMPONENT DAMAGE HAZARD

Failure to follow this caution may result in unit component damage.

DO NOT clean filters in a dishwasher and DO NOT dry them with a heating appliance or permanent damage will result.

Blower Motor and Wheel

HRV blower motors are factory lubricated for life. Lubricating bearings is not recommended. However, inspect and clean any accumulated dirt and grease from blower motor and wheel annually.

Cleaning the Core

HRV unit is equipped with special heat recovery core and must be handled with care. We recommend that it be washed once a year following the season of most intense use. This will ensure maximum efficiency of the plastic partitions within the core.

Allow heat recovery core to soak for 3 hours in a solution of warm water and mild soap. Rinse under stream of water. Hot water and strong detergent will damage core and should NOT be used.

TROUBLESHOOTING

⚠ **WARNING**

ELECTRICAL SHOCK HAZARD

Failure to follow this warning could result in personal injury or death.

Before installing or servicing system, always turn off, tag and lockout main power to system. There may be more than 1 disconnect switch.

⚠ **CAUTION**

CUT HAZARD

Failure to follow this caution may result in personal injury.

Sheet metal parts may have sharp edges or burrs. Use care and wear appropriate protective clothing and gloves when handling parts.

NOTE: Reference Table 7 Troubleshooting Chart

This can be a quick guide in resolving unit problems. It is also recommended to review and understand Wall Control Board Operation and Care and Maintenance sections before continuing. There are 3 main parts to focus on when troubleshooting HRV unit: **wall control, electronic control board and blower motor.**

Wall Control

Typically, the wall control is either good or it is bad. Use Table 1, 2, 3, or 4 to determine if wall control is operating correctly. Use Fig. 11 to check control wire connections.

NOTE: The electronic control board and wall control operate on 12vdc.

Control Board

Electronic control board must have wall control attached before unit will function properly (except for units equipped with manual switch such as the new horizontal units). Also, configuration jumpers located on control board must match configuration setup shown on Fig. 18 under Jumper Table. In addition, outside air thermistor must be connected to control board for it to operate properly. See Table 6, Temperature/Ohm Relationship, for valid temperature range.

Blower Motor

The HRV blower motor operates on 115VAC, with 2-speed operation.

The easiest way to check blower speed operation is to use the wall control and initiate a low-speed blower and high-speed blower operation.

NOTE: If there is a short circuit or an open circuit at thermistor, CPU will go into a 5 minute defrost cycle every 20 minutes. This feature is not there on older board versions with 3 pin jumpers.

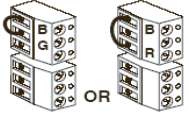

Table 6 – Temperature/Ohm Relationship

TEMP (°F/°C)	OHMS
30/-1	34,480
32/0	32,630
34/1	30,760
36/2	29,220
38/4	27,470
40/5	26,020
42/6	24,680
44/7	23,320
46/8	22,070
48/9	20,910
50/10	19,830
52/11	18,820
54/12	17,870
56/14	16,920
58/15	16,160
60/16	15,260
62/17	14,530
64/18	13,790
66/19	13,090
68/20	12,480
70/21	11,860
72/22	11,270
74/24	10,750
76/25	10,250
78/26	9,750
80/27	9,300
82/28	8,840
84/29	8,432
86/30	8,042
88/31	7,668
90/32	7,310
92/33	6,993
94/34	6,661
96/35	6,368
98/36	6,085
100/38	5,811
102/39	5,571
104/40	5,313
106/41	5,088
108/42	4,869
110/43	4,660
112/44	4,450
114/46	4,268
116/47	4,019
118/48	3,918
120/49	3,750

HRV

Be sure to unplug and inspect the unit before proceeding with these steps. Start with problem 1, then problem 2 and so on.

Table 7 – Troubleshooting

Problem:	Possible causes:	You should try this:
1. Unit does not work.	<ul style="list-style-type: none"> • Erratic operation of the electronic circuit. • The breaker in the electrical panel may be tripped. • The door switch may be defective • The circuit board may be defective. • The power cord fuse may be blown. (Except for -1330 models.) • The fan motor may be defective. • The 9-pin connector may have a loose connection. 	<ul style="list-style-type: none"> • Unplug the unit. Wait for 30 seconds. Plug it back in. • Reset breaker. If it trips again, unplug the unit and call an electrician. • Using a multimeter, check for power across the switch (the door switch must be pushed in for this test). If there is no power, replace the switch. • Jump “B” and “G” (BLACK and GREEN) or “B” and “R” (BLACK AND RED). If unit switches to high speed, remove the wall control and test it right beside the unit using another shorter wire. If the wall control works there, change the wire. If it does not, change the wall control. • Unplug the unit. Unscrew the fuse holder in the power cord. Check if the fuse is blown (the strand is broken). If the fuse is blown, replace the fuse according to the specifications on the wiring diagram. • Unplug the unit and disconnect the fan motor (4 wires). Supply 120 V directly to the GREY and ORANGE wires of the fan motor. Replace the motor if not working. • Unplug the unit and check to make sure all the crimp connections are sound. Check the fan motor and the damper actuator connections as well. 
2. One fan motor does not work. (-1330 models only)	<ul style="list-style-type: none"> • The fan motor fuse F2 or F3 may be blown. 	<ul style="list-style-type: none"> • Unplug the unit. Unscrew the F2 and F3 fuse holders on the lower right side of the unit and check if the fuses are blown (the strand is broken). If it is blown, replace the fuse according to the specifications on the wiring diagram.
3. The damper actuator does not work.	<ul style="list-style-type: none"> • The 9-pin connector may have a loose connection. • The damper actuator may be defective. • The circuit board may be defective. 	<ul style="list-style-type: none"> • Unplug the unit and check to make sure all the crimp connections are secured. Check the damper actuator connections as well. • Feed 120 V directly to the damper actuator. If the problem persists, replace the damper actuator. • Replace the circuit board if the problem is not solved by the above.
4. The wall control will not work.	<ul style="list-style-type: none"> • The wire in the wall OR the wall control may be defective. • The wires may be in reverse position. • The wires may be broken. • There may be a short-circuit. 	<ul style="list-style-type: none"> • Remove the wall control and test it right beside the unit using another shorter wire. If the wall control works there, change the wire. If it does not, change the wall control. • Ensure that the color coded wires have been connected to their appropriate places. • Inspect every wire and replace any that are damaged. • With the help of a multimeter, check for continuity.
5. The 20-minute lighted push-button switch doesn't work OR its indicator light doesn't stay on.	<ul style="list-style-type: none"> • The switch may be defective. • The wires may be defective OR may not be connected properly. 	<ul style="list-style-type: none"> • Jump the OL and OC terminals. If the unit switches to high speed, then the wires are not the problem. Replace the push-button. • Ensure that the color-coded wires have been connected to their appropriate places. 
6. The defrost cycle does not work (the fresh air duct is frozen OR the fresh air distributed is very cold.)	<ul style="list-style-type: none"> • Ice deposits may be hindering the damper operation. • The damper rod or the port damper itself may be broken. • The damper actuator may be defective. • The circuit board may be defective. • The thermistor may be defective. 	<ul style="list-style-type: none"> • Remove the ice. • Inspect these parts and replace if necessary. • Plug in the unit and select “OFF”. Press the door switch and see if the port damper closes. If it does not close, feed 120V directly to the damper actuator. If the port damper still does not close, replace the damper actuator. • Unplug the unit. Unplug the defrost sensor wire (see J4 on electrical diagram). Plug the unit back in. Select “MIN” and make sure the unit is adjusted for low speed operation. Wait 3 minutes. The unit should switch to high speed and the damper at the fresh air intake port should close (defrost mode). If this does not happen, then replace the circuit board. • If the defrost mode works well after having disconnected the thermistor wire (above test), this means the thermistor is probably defective. It should be replaced.

HRV

Override Test

To use override test function, a thermistor must be connected to the control board. Unit must not be in defrost mode during an override test.

HIGH SPEED

1. Disconnect HRV from 115VAC.
1. Unplug wall control wires at control module terminal block inside HRV.
2. Plug HRV back to 115VAC.
3. Attach a wire across J3-8 and J3-9 (B and G) on control module terminal block.
4. Push in door switch, this will initiate a high-speed exchange.

LOW SPEED

1. Unplug HRV from 115VAC.
2. Disconnect wall control wires at control module terminal block inside HRV.
3. Plug HRV back to 115VAC.
4. Connect a 3.0 K ohm resistor between J3-8 and J3-9 (B and G) on control module terminal block.
5. Push in door switch, this will initiate a low-speed exchange.

Blower Speed Selection

Three-speed blowers are factory connected to electronic control board on HIGH- and LOW-speed taps of blowers. Installer can easily change low-speed tap to medium-speed tap so electronic control will select between high and medium speed. Connections can be changed at motor location (see Table 8 and Table 9).

To change low speed to medium speed, proceed as follows:

1. Unplug unit from 115VAC.
2. Locate blower assembly.
3. Locate red wire and blue wire coming from blower assembly.
4. Unplug red wire from quick connect.
5. Unplug protecting cap quick connection from blue wire and put on red wire coming from blower. The cap is a safety insulator.
6. Connect red wire of main harness to blue wire.
7. Replace wires.

Table 8 – Factory Set Blower Connection High or Low Speed

CONTROL MODULE	MAIN ELECTRICAL HARNESS CABLE	BLOWER WIRE	SPEED
J1-6	Orange	Orange	High
No Connection	No Connection	Blue + Cap	Medium
J1-4	Red	Red	Low

Table 9 – Modify Blower Connection High or Medium Speed

CONTROL MODULE	MAIN ELECTRICAL HARNESS CABLE	BLOWER WIRE	SPEED
J1-6	Orange	Orange	High
J1-4	Red	Blue	Medium
No Connection	No Connection	Red + Cap	Low

Table 10 – Temperature and Voltage

VOLTAGE DC VOLTS (J4)	TEMP °F (°C)
3.5	-22 (-30)
2.7	-4 (-20)
2.3	4 (-15)
2.0	14 (-10)
1.4	32 (0)
1.1	41 (5)
0.9	50 (10)
0.6	68 (20)

Defrost Cycle

Defrost cycle is controlled by a thermistor which is located in the fresh-air intake passage (the thermistor unit is connected to J4 of control module (see Fig. 17 and Fig. 18). When defrost temperature sensor detects the need for defrost, K5 relay will close for 6 minutes while K1 and K2 remain energized.

This closes the outdoor air damper while running HRV blower on high-speed. This process recirculates warm indoor air through heat recovery core which melts any frost that has formed. Water created in this process is collected by HRV and drained away. Frequency of the defrost cycle depends on outdoor temperature (see Table 11).

Table 11 – Defrost Cycle

OUTSIDE TEMPERATURE	STANDARD DEFOST (AS SHIPPED)	EXTENDED DEFOST (JUMPER JU1-F REMOVED)
Above 23°F/-5°C	No Defrost	No Defrost
23°F to 5°F/-5°C to -15°C	6 Minute Defrost/32 Minute Exchange	10 Minute Defrost/30 Minute Exchange
4°F to -17°F/-16°C to -27°C	6 Minute Defrost/32 Minute Exchange	10 Minute Defrost/20 Minute Exchange
Below -18°F/-28°C	6 Minute Defrost/20 Minute Exchange	10 Minute Defrost/15 Minute Exchange

Table 12 – JU1 Jumper Definition

JU1A	JU1B	JU1C	JU1D	JU1E	JU1F	JU1G
UNIT IDENTIFICATION				Reverse Damper Operation In=Normal Out=Inverse	Factory Set Always In	Factory Set Always In

Table 13 – Jumper Locations

MODEL	JUMPER TABLE						
	JU1A	JU1B	JU1C	JU1D	JU1E	JU1F	JU1G
HRVCLHA1150	OUT	OUT	OUT	OUT	IN	IN	IN
HRVCLHA1250	OUT	OUT	OUT	OUT	IN	IN	IN
HRVCLVU1330	OUT	OUT	OUT	OUT	IN	IN	IN

HRV

If defrost is not working properly, check for proper damper operation. To do this, turn unit to OFF position. Damper should close.

Safety Feature

This new control has an added safety feature. If microprocessor does not detect the thermistor or detects a short circuit, unit will automatically go into a 6 minute defrost cycle every 20 minutes.

Defrost Check

1. Make sure defrost cable is properly connected into J4.
2. Make sure thermistor assembly is correct. Measure thermistor temperature reading with multimeter. Select multimeter DC measurement scale 0-20v. At connector J4 (without removing thermistor cable), measure voltage between pins of thermistor cable. Depending on temperature of outside air intake, values should correspond with those in Table 9.
3. If reading is not correct (reading 0v for short circuit or 5v for open circuit), change thermistor assembly.

Advanced Debugging

Defrost can be simulated using the following procedures:

1. Unplug unit from 115VAC.
2. Disconnect thermistor assembly from J4.
3. Replug unit in 115VAC and select high-speed exchange.
4. Defrost should start within 2 minutes after high-speed exchange has been initiated.
5. After test unplug unit.
6. Connect thermistor cable to J4.
7. Replug unit back in 115VAC.

Control Module Jumpers

Jumpers on the control module give exact configuration to HRV micro-controller. If there is a mistake in the jumper configuration, it can cause improper unit operation. This control has a simplified jumper selection mode. Jumper selection is done by the presence or absence of jumper at specific location (see Tables 12 and Table 13).

⚠ WARNING

ELECTRICAL SHOCK HAZARD

Failure to follow this warning could result in personal injury or death.

Always disconnect unit from 115VAC prior to making any jumper change. If unit is not disconnected, micro-controller will never see jumper change.

Error Signaling

Two types of error can be signaled by the wall control (automatic wall control only). In case of error, indicators on wall control will flash.

When error occurs, set dehumidistat at 80% position. This will enable you to properly troubleshoot problems.

Type 1—Loss of Memory (Auto Model Only)

All indicators flash rapidly (rate of about once very sec). When this occurs, reset power and check if problem still exists. If indicators are still flashing, check red wire for shorting on another component. If error still exists, wall control has lost its memory. Replace wall control.

The defective wall control still works even when flashing, it is working in backup mode. Original modes of wall control are replaced by backup mode (see Table 14).

Table 14 – Backup Mode

MODES	WALL CONTROL BACKUP MODE
OFF	OFF
1	INTERMITTENT
2	LOW-SPEED EXCHANGE
3	HIGH-SPEED EXCHANGE

Type 2—Communication Problem or Unsupported Mode (Auto Model Only)

All indicators flashing at a rate of about once every 8 sec. Communication is not properly entered or is not working.

CASE 1

User changes the mode on wall control and HRV does not respond to command (OFF, LOW, or HIGH speed). Check all wires to wall control particularly red wire (see Table 15).

CASE 2

User changes the mode but, HRV does not respond. All indicators flash at a rate of about once every 8 sec. Check all wires to wall control particularly green wire. If problem still exists, test wall control with 5 ft (1.5 m) of wire from HRV. If this works, change wall control module inside HRV.

RESET

To reset HRV, proceed as follows:

1. Unplug HRV from 115VAC.
2. Wait 15 sec.
3. Plug HRV into 115VAC.

Table 15 – System Wiring Colors and Connections

CONTROL MODULE		WALL CONTROL WIRE	WALL CONTROL	
Terminal Block No.	Terminal Block Identification	Color	Terminal No.	Terminal Identification
J3-9	B	Black	J1-4	B
J3-8	G	Green	J1-3	G
J3-7	R	Red	J1-2	R
J3-6	Y	Yellow	J1-4	Y

Energy Star (Canada)

- HRVCCLHA1150
- HRVCCLVU1330



These products earned the ENERGY STAR® by meeting strict energy efficiency guidelines set by Natural Resources Canada and the US EPA. They meet ENERGY STAR requirements only when used in Canada.