

# Installation Instructions

**NOTE:** Read and become familiar with these instructions before beginning installation.

## SAFETY CONSIDERATIONS

Installing and servicing air-conditioning equipment can be hazardous due to system pressures and electrical components. Only trained and qualified personnel should install or service air-conditioning equipment. When working on air-conditioning equipment, observe the precautions provided in literature, tags, and labels attached to the unit.

Follow all safety codes. Wear safety glasses, protective clothing, and work gloves. Use quenching cloth for brazing operations. Have fire extinguisher available. Read these instructions thoroughly and follow all warnings or cautions included in literature and attached to the unit. Consult local building codes and National Electrical Code (NEC) for special requirements.

Recognize safety information. This is the safety-alert symbol . When you see this symbol on the unit and in instructions or manuals, be alert to the potential for personal injury.

Understand these signal words: DANGER, WARNING, and CAUTION. These words are used with the safety-alert symbol. DANGER identifies the most serious hazards which **will** result in severe personal injury or death. WARNING signifies hazards which **could** result in personal injury or death. CAUTION is used to identify unsafe practices which **may** result in minor personal injury or product and property damage. NOTE is used to highlight suggestions which **will** result in enhanced installation, reliability, or operation.

## WARNING

### ELECTRICAL SHOCK HAZARD

Failure to follow this warning could result in personal injury or death.

Before beginning any modification or installation of this kit, be sure the main electrical disconnect is in the OFF position. Ensure power is disconnected to the fan coil unit. On some systems both the fan coil and the outdoor unit may be on the same disconnect. Tag the disconnect switch with a suitable warning label. There may be more than one disconnect.

**Table 1—Package Contents**

ITEM	QUANTITY
Power Ventilation Fan – 240v Single Phase	1
Worm Clamps*	4
Speed Controller	1
Fan Mounting Bracket (from fan supplier)	1
Transformer / Control Relay (SPST) – 24v Coil (VCR)	1
Wire Nuts	9
Current Sensor	1

#### LEGEND:

SPST – Single pole, single throw

\*Not used on all installations.

In addition to accessory package, the following parts will need to be field-supplied:

- One (1) 2-1/2 in. deep electrical 2 X 4 junction box.
- Flex duct (4-in. diameter) or galvanized pipe (long enough to meet job requirements).
- One (1) wall termination with screen.
- Two (2) 14-gauge (minimum) wires and one (1) 14-gauge (minimum) ground wire (long enough to meet job requirements).
- One (1) 4-in. round duct adapter.

#### GENERAL

The accessory power ventilation kit is designed for use with the 40KMC, KMQ / 619FNF, FNQ fan coil (indoor cassette) units (see Fig. 1). This kit will overcome air static losses in the ventilation air supply duct when the indoor unit fan is not capable of overcoming inlet static to provide the required ventilation. The fan is integrated into the control system of the fan coil unit and will operate whenever the unit fan operates.

A current sensing device is installed into the unit control wiring area by clamping around fan motor wires. (No need to cut and splice unit wiring.) The power vent can be set up to run with all indoor unit fan speeds or any combination thereof.

A speed controller is provided to allow balancing ventilation air for the application depending on air inlet restrictions. **Do not** exceed 20% of high speed maximum CFM on 40KM/619F units (see Table 2).

**Table 2—Maximum CFM Setting**

UNIT	HIGH SPEED MAXIMUM CFM	MAXIMUM CFM SETTING*
40KMC018 / 619FNF018	470	94
40KMC01824 / 619FNF01824	690	138
40KMC03036 / 619FNF03036	910	182
40KMQ01824 / 619FNQ01824	690	138
40KMQ03036 / 619FNQ03036	910	182

\*20% of high speed maximum.

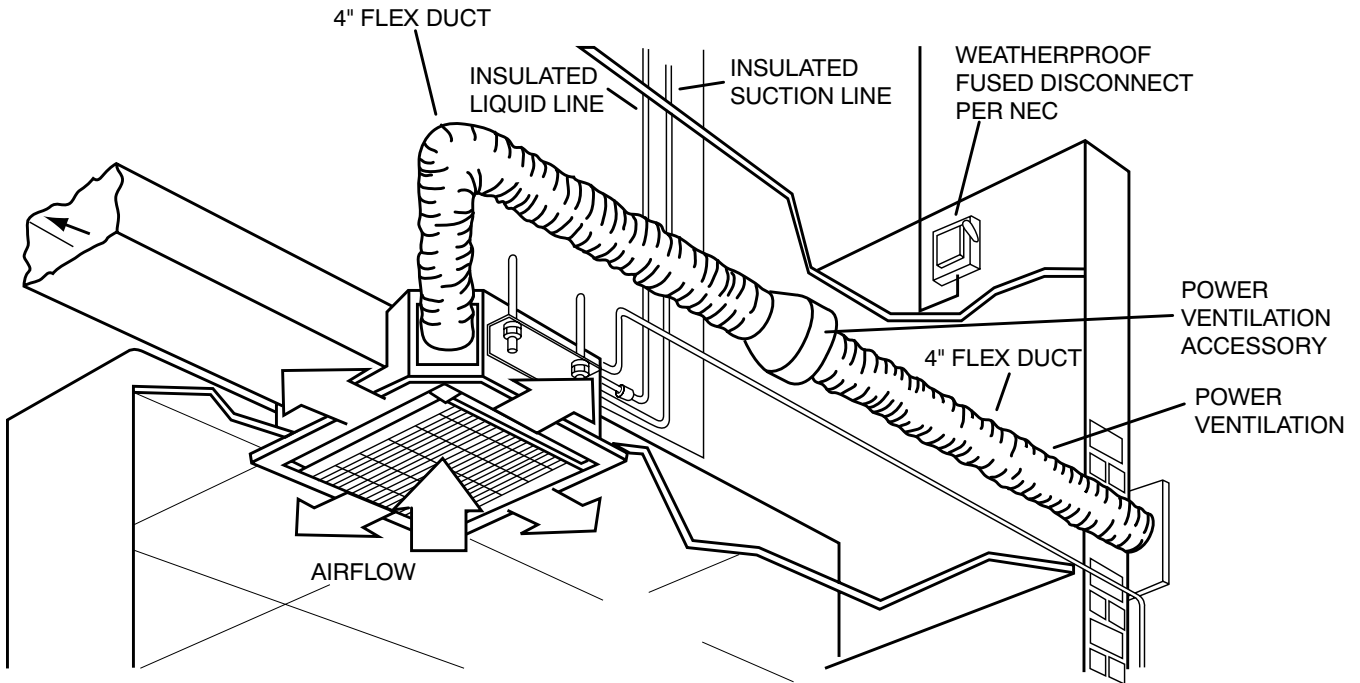

**Fig. 1 – Power Ventilation Kit**

A07268

## INSTALLATION

The 40KMC, KMQ / 619FNF, FNQ units can be used for fresh-air ventilation. Plan the installation carefully. Measure carefully and follow acceptable building practices and the National Electric Code (NEC).

### STEP 1 —Fresh Air Intake

1. Using Fig. 2, locate and remove the factory-installed insulation from the side of the unit where the prepunched knockouts are located.
2. Remove the pre-punched knockouts for fresh air intake. Refer to Fig. 2. Be careful not to damage internal parts such as the heat exchanger coil.
3. If installing unit size 018, install baffle. Refer to Fig. 2.
4. Install ductwork using field-supplied, insulated flex duct, or insulated sheet metal suitable for working temperatures up to 140°F. Conduits can be of flexible polyester (with spiral core) or corrugated aluminum, externally covered with anti-condensate material (fiberglass from 1/4-in. (6 mm) to 1-in. (25 mm) thickness).

**IMPORTANT:** Ventilated air must not exceed 10% of the total airflow or problems with operation will result. If the ventilated air surpasses 10% of the total airflow, a field-supplied primary air treatment system with separate deflectors is recommended.

5. Install an air inlet grille with filter inspection port to prevent dust and dirt from entering and fouling the indoor unit heat exchanger. Filter installation will help reduce air movement during power vent OFF cycle. However, a back-draft damper would prevent all air movement during power vent OFF cycle.
6. All non-insulated ducts must be covered with anti-condensate insulation (such as expanded neoprene, 1/4-in. (6 mm) thickness).

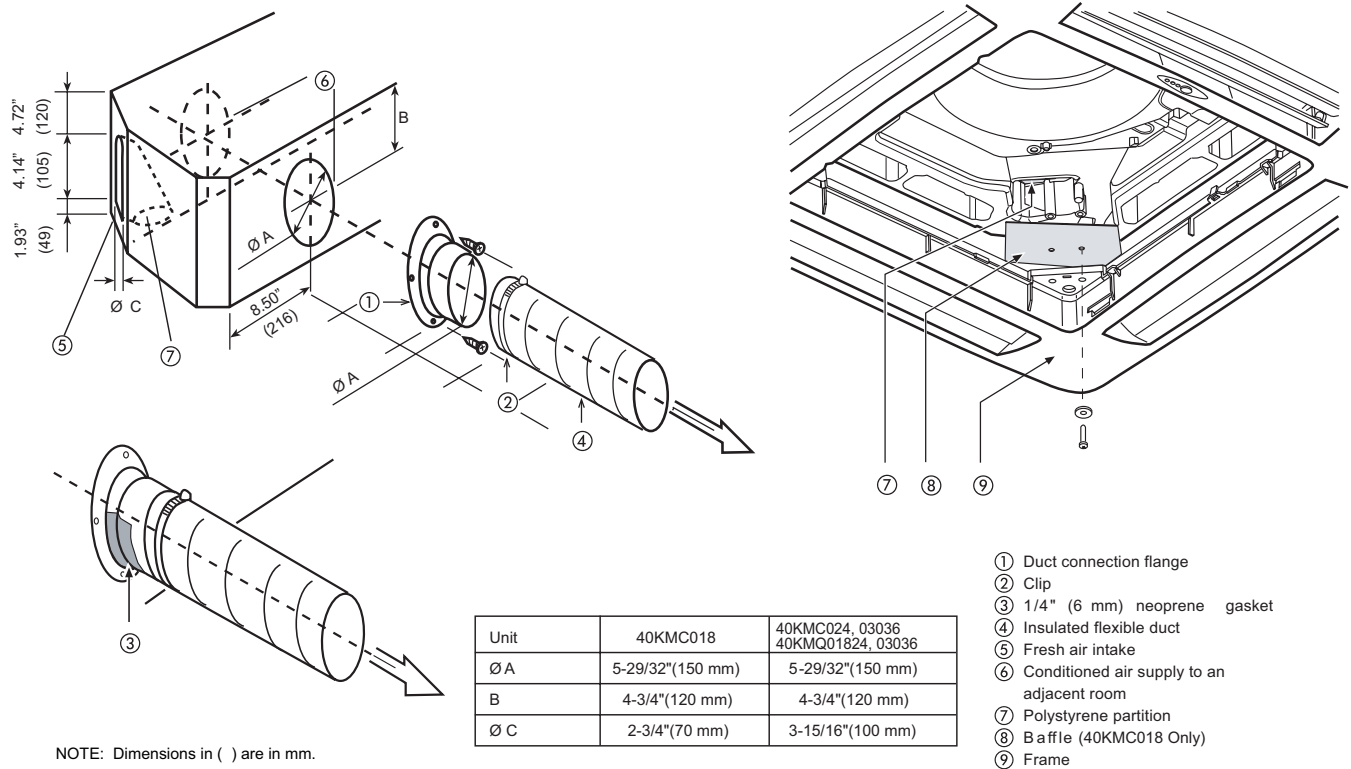

**Fig. 2 – Installation Options**

A07269

### STEP 2 —Complete Unit Installation

Proceed with installation of the fan coil unit per the fan coil installation instructions. If the fan coil unit had been previously installed and removed to install this accessory, re-install fan coil unit at this time

### STEP 3 —Install Power Ventilation Fan

Select a location to mount the ventilation fan. The best location is as close to the outdoor-air intake as possible and not over an occupied space. The ventilation fan may be mounted in any position by attaching the mounting bracket provided to both the fan and a building structure support. To reduce any fan-induced vibration, provide vibration isolation. See Fig. 3 for fan mounting choices.

### STEP 4 —Install and Attach Ductwork to Unit and Fan

Install the field-supplied wall termination for ventilation-air inlet. Attach field-supplied 4-in. flex duct or pipe from the wall termination to the ventilation fan and from the ventilation fan to mounting collar on unit.

**IMPORTANT:** Be sure that the fan flow arrow points toward the fan coil unit.

If using flex duct, clamp the duct to the fan inlet, outlet and mounting collar with the four (4) clamps provided. If galvanized duct is used, attach the duct with sheet metal screws and duct tape for a tight seal.

**IMPORTANT:** When using screws, be sure the screws do not interfere with fan rotation.

### STEP 5 —Installation of Ventilation Speed Control and Transformer/Relay Box

These two boxes may be attached together or separately. The power vent kit may be powered from the cassette unit or from a separate power source. The fan operates on 220-240vac and the control circuit is 24vac.

**NOTE:** Follow all local electrical codes for wire size, conduit (if required) and grounding.

1. Mount the speed control box (2x4 field-supplied) and transformer/relay box.

2. Run 240vac power source and low voltage control wiring into the transformer/relay box. (See Fig. 5)
3. The cassette unit control box area must be opened to gain access to the fan motor wires. See unit Installation Instructions.
4. Install the current sensing device - attach two (2) low voltage wire ends prior to installation (yellow wires provided). Remove and discard the mounting foot (if present) on the sensing device.
5. Clamp the device around the motor wires (black, grey, and blue).

**NOTE:** The power vent may be set up to operate with all fan speeds or any combination of fan speeds by selecting which wires to pass through the sensor. High speed - grey, medium - black, low speed - blue.

6. Position the current sensing device in the unit, see Fig. 5 for detail.
  - c. **For small cassette size (40KMC018 / 619FNF018),** remove the emergency push-button (item 6, Fig. 5), place the current sensing device as shown in the diagram with wire connection end towards capacitor (item1, Fig. 5), and reinstall the emergency push-button. Sensor will not operate properly unless it is oriented in this position.
  - d. **For all other size units:** Place the current sensing device in the area shown. Installer may want to secure the sensor with a wire tie if necessary.
7. Run the low voltage wiring back to the unit junction box, following the wireway channel and make the connection in the junction box.
8. Make all other final wiring connections according to schematic in Fig. 4.
9. Mount speed controller to it's device box and attach cover to transformer/relay box.

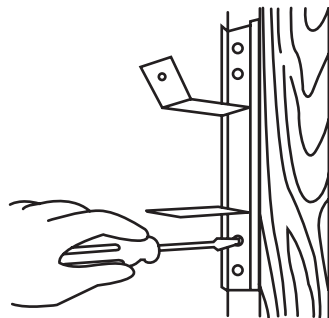

A07172

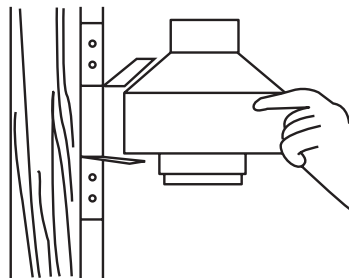

USING FAN MOUNTING BRACKET

A07174

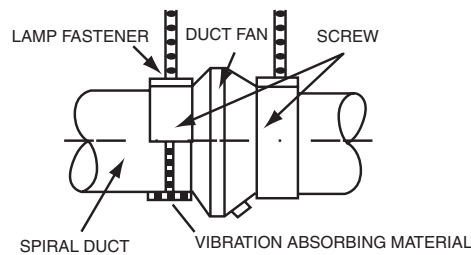

SUSPENDED WITHOUT BRACKETS

A07173

Fans may be suspended by threaded rod.

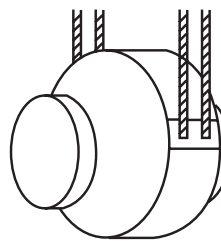

SUSPENDED USING THREADED ROD

A07175

Fig. 3 – Vent Fan Mounting Methods

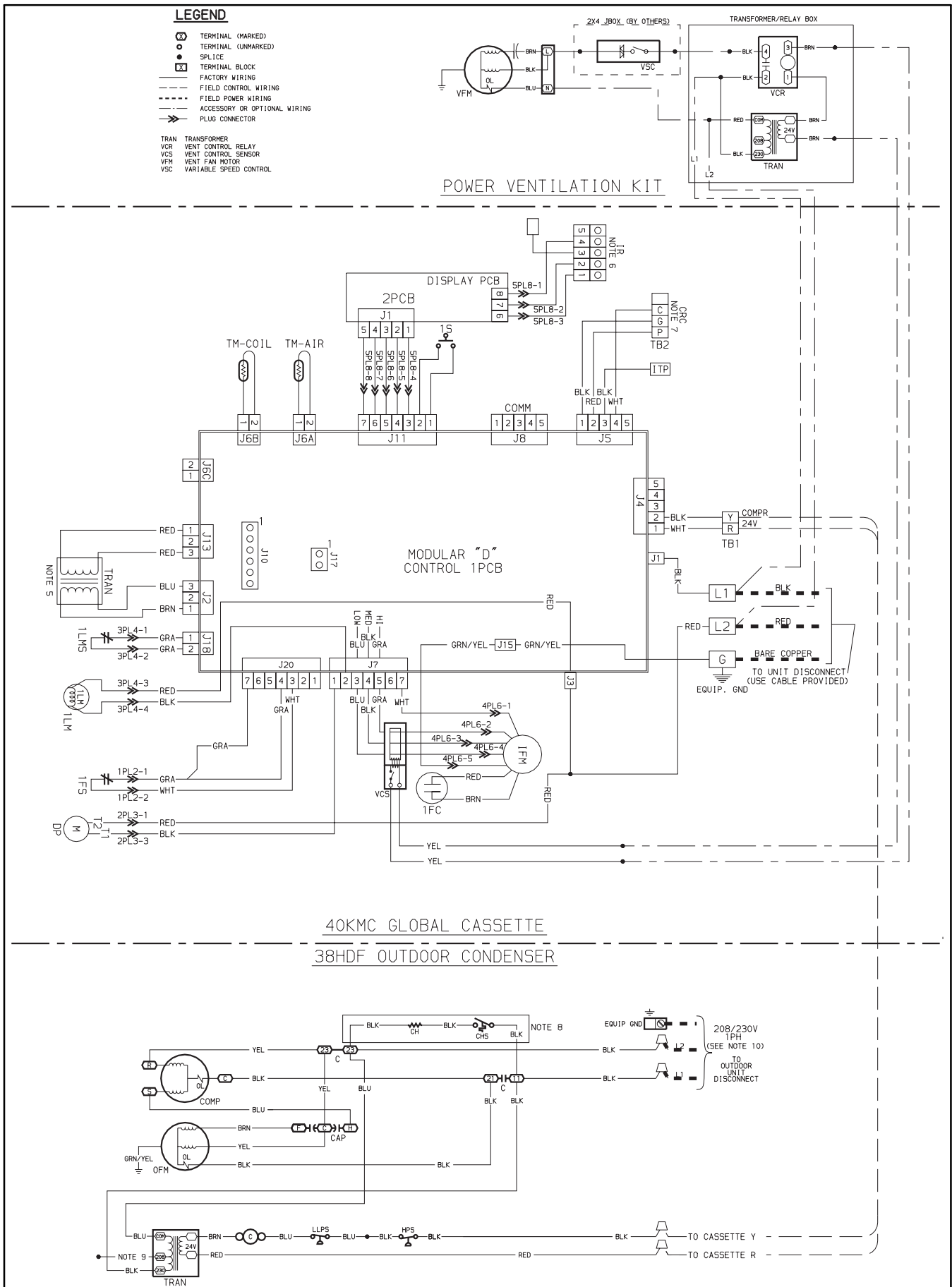
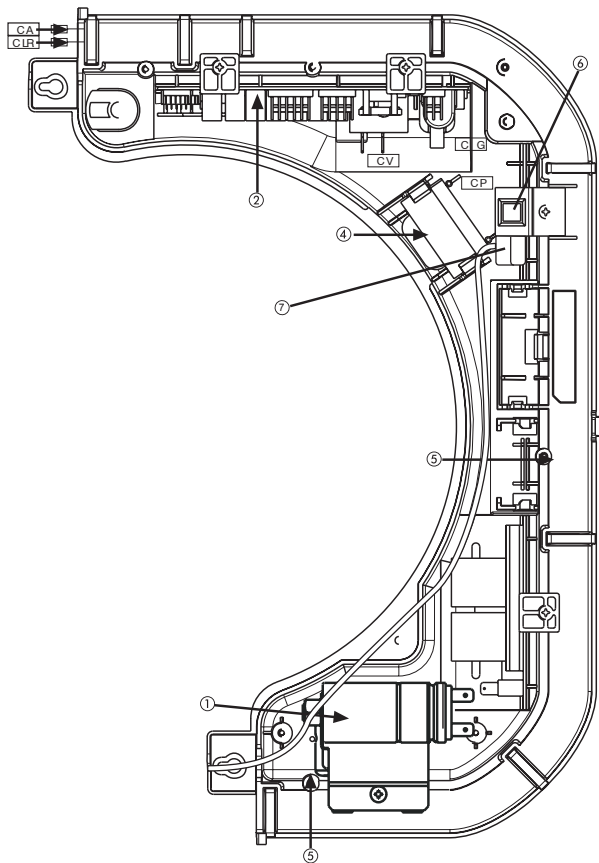
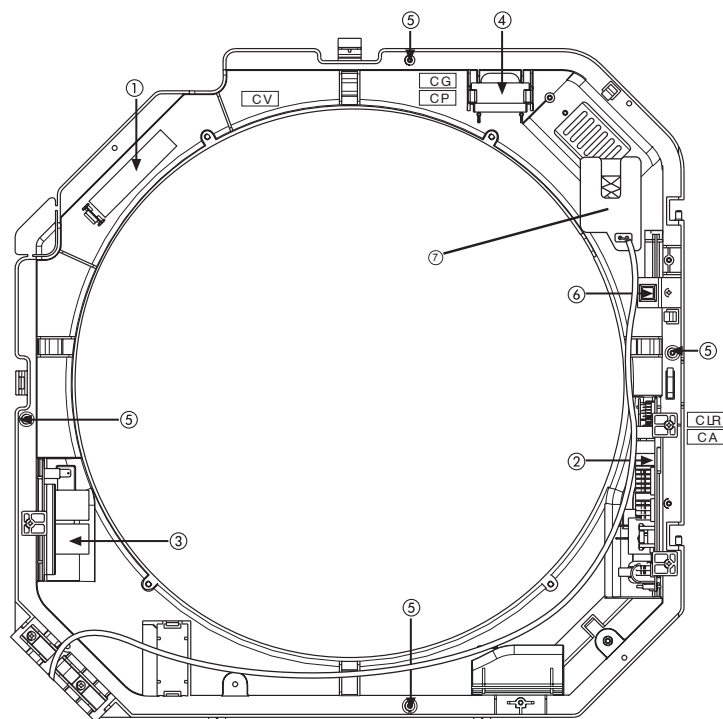

Fig. 4 – Typical Wiring



**INTERNAL CONTROL PANEL**  
40KMC018



**INTERNAL CONTROL PANEL**  
40KMC024-036  
40KMQ018-036

- ① Capacitor
- ② GMC board
- ③ Electric heater board  
(only on models with electric heater)
- ④ Transformer
- ⑤ Holes for fixing panel in position
- ⑥ Emergency push-button
- ⑦ Vent control sensor

- CV Fan connector
- CLR LED/RECEIVER connector
- CG Float connector
- CP Pump connector
- CA Louver connector

**Fig. 5 – Internal Control Panel**

A07177

### STEP 6 —Set Minimum Speed Adjustment

After basic start-up of the fan coil unit is complete, set the vent fan minimum position. With the motor running, the flexible duct or stove pipe attached, and the fan coil unit operating at high speed:

1. Turn the main control knob clockwise to the lowest position.
2. Locate and adjust minimum speed setting on the front plate of the speed control with a screwdriver. Rotate in a clockwise direction to decrease minimum speed or in a counterclockwise direction to increase minimum speed.
3. Install the front dial plate on the variable speed control.
4. Push the knob onto the main control shaft. The pointer should point to the OFF position.

### STEP 7 —Adjust to Required Airflow

The required minimum airflow must now be set. Be sure the fan on the fan coil unit is operating at high speed and that all grilles and filters on unit and vent fan are installed. If possible, the best way to set airflow is with a hot wire anemometer or a pitot tube to measure the air in the ventilation inlet duct. Be sure to stay below 20% of the maximum high speed CFM on 40KM/619F units. Airflow is adjusted using the ventilation fan speed control.

If the airflow temperature cannot be measured, the necessary airflow temperature can be determined by the air mixing equation below. The equation applies if the difference between indoor and outdoor air temperature is 20°F or greater. To calculate the airflow:

1. Measure the indoor, outdoor, and discharge air temperatures without the unit running (the fan must be running) in either heating or cooling.
2. Calculate the required discharge-air temperature using the following equation:

$$\begin{aligned} \text{Required discharge temperature} = & \\ & \left( \text{outdoor-air temperature} \times \frac{\text{required \%}}{100} \right) \\ & + \\ & \left( \text{indoor-air temperature} \times \frac{[1 - \text{required \%}]}{100} \right) \end{aligned}$$

**NOTE:** The required vent air percentage is determined by the job requirements.

3. Adjust the vent fan airflow with the speed control to obtain the required discharge-air temperature.

**Example:**

Required vent air percent = 20%  
Indoor-air temperature = 70°F  
Outdoor-air temperature = 90°F

$$\begin{aligned} \text{Required discharge temperature} = & \\ & \left( 90 \times \frac{20}{100} + (70 \times [1 - \frac{20}{100}]) \right) \end{aligned}$$

Required discharge temperature = 74°F

### TROUBLESHOOTING

If the ventilation fan fails to operate when the indoor unit fan operates, check the following:

- Is appropriate fan speed motor wire passed through the current sensing relay?  
(High speed - grey, medium speed - black, low speed - blue)  
The vent fan will operate only in cassette unit fan speeds in which fan motor wires are passed through the vent control sensor.
- Is the ventilation control relay energized in high speed?  
(Check for 230v to the relay coil and at normally-open contact no. 2 of the relay.)
- Is the speed controller adjusted properly and was the minimum fan position set per Step 6?
- Check that the ventilation fan capacitor is working correctly.
- If the ventilation fan motor hums, check for correct wiring of the ventilation fan capacitor and speed controller. See Fig. 4.

