

Installation Instructions

SAFETY REQUIREMENTS

Installing and servicing heating equipment can be hazardous due to gas and electrical components. Only trained and qualified personnel should install, repair, or service heating equipment.

Untrained service personnel can perform basic maintenance functions such as cleaning and replacing air filters. All other operations must be performed by trained service personnel. When working on heating equipment, observe precautions in the literature, on tags, and on labels attached to or shipped with the furnace and other safety precautions that may apply.

Follow all safety codes. In the United States, follow all safety codes including the National Fuel Gas Code (NFGC) ANSI Z223.1-2006/NFPA 54-2006. In Canada, refer to the National Standard of Canada Natural Gas and Propane Installation Code (NSCNGPIC) CAN/CGA-B149.1 and .2-M-05.

Wear safety glasses and work gloves. Have fire extinguisher available during Start-up, Adjustment steps, and service calls.

Recognize safety information. This is the safety-alert symbol . When you see this symbol on the furnace and in instruction manuals be alert to the potential for personal injury.

Understand the signal words *DANGER*, *WARNING*, or *CAUTION*.

These words are used with the safety-alert symbol. *DANGER* identifies the most serious hazards, those that **will** result in severe personal injury or death. *WARNING* signifies a hazard that **could** result in personal injury or death. *CAUTION* is used to identify unsafe practices that **may** result in minor personal injury or product and property damage. Note is used to highlight suggestions that will result in enhanced installation, reliability, or operation.

This conversion kit shall be installed by a qualified service agency. Please read these instructions completely before attempting installation. Consult gas supplier and tables in National Fuel Gas Code NFPA 54/ANSI Z223.1, 2006 or latest edition. In Canada, the National Standard CAN/CGA B149-1 and B149-2-05.

Parts List

Description	Part #	Qty.
Burner Orifice #54	1011376	5
Honeywell Conv. Kit #396021	1011828	1
Switch, Low Pressure (LGPS)	1008801	1
Fitting Assy.	1009775	1
Inlet Fitting	1147904	1
Wire Assy.	1173071	1
Label, Field Conversion	1009678	1
Label, Propane Conversion	333675-101	1
Label, Derate	2505235	1
Instructions	I1KKGANP4401-001	1

Orifices for High Altitude Conversion

(Refer to **Table 1** - for required orifice)

Description	Part #	Qty.
Burner Orifice #55	1011354	5
Burner Orifice #56	1011355	5



⚠ WARNING

FIRE, EXPLOSION, ELECTRIC SHOCK, AND CARBON MONOXIDE HAZARD

Failure to follow this warning could result in personal injury, death, or property damage.

This conversion kit shall be installed by a qualified service technician in accordance with the Manufacturer's instructions and all applicable codes and requirements of the authority having jurisdiction. The qualified service agency is responsible for the proper installation of this kit. The installation is not proper and complete until the operation of the converted appliance is checked as specified in the manufacturer's instructions supplied with the kit.

General Information

This kit is for conversion of furnaces equipped with Honeywell VR8205Q Series 2-stage gas valves certified for use with Natural Gas (and so marked) to units functionally the same as the certified furnace for use with Propane Gas. Before the furnace can be operated with Propane Gas, the Propane low pressure switch must be installed and a gas valve conversion kit must be installed and main burner orifices must be replaced **with properly sized orifices**.

The orifices provided in this kit are stamped to indicate the size (twist drill number) and are sized for commercially pure propane gas **ONLY**. Do NOT use them with butane or a mixture of butane and propane gas. The parts list specifies the size orifices supplied in the kit. Compare the size marking on the orifices with the sizes as listed in the parts list. Make sure you have the correct main burner orifices.

Extreme care is used to assure that this kit contains the proper orifices. Oversized orifices could result in hazardous conditions, especially if the venting is inadequate. For that reason, we recommend that the installer check the size of the orifice with a new twist drill of the correct size. This procedure assures that the orifices provided are the correct size.

Installation

⚠ WARNING

ELECTRIC SHOCK, FIRE, AND EXPLOSION HAZARD

Failure to follow this warning could result in death, personal injury, or property damage.

Turn OFF gas supply at manual gas valve before turning OFF electric power supply and starting conversion

Turn OFF electric power supply at disconnect switch or service panel before starting conversion.

Disassembly

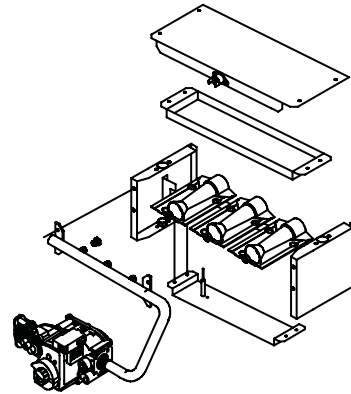

Fig. 1 - Disassembly

A07838

Refer to Fig. 1 and the following steps.

1. After disconnecting power and gas supply to the furnace, remove the access door, exposing gas valve and burner compartment.
2. Disconnect gas line from gas valve so manifold assembly can be removed.
3. Disconnect wiring at gas valve. Be sure to note the proper location of any and all electrical wiring disconnected.
4. Remove the screws holding the manifold and gas valve to the manifold supports. Do Not discard any screws.
5. Carefully remove the manifold assembly.

Main Burner Orifices

1. Remove the Natural gas (brass) burner orifices from the manifold assembly and replace them with the appropriate Propane (silver) orifices furnished in the conversion kit (Fig. 2), unless converting a high altitude unit, then see Table 1 for appropriate orifices.

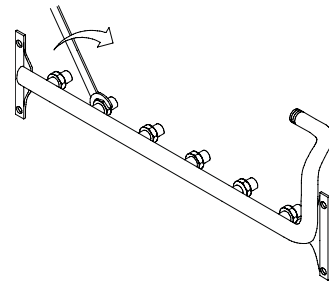

Fig. 2 - Remove Orifices

A07839

2. Tighten the orifices so they are seated and gas tight about $1\text{-}\frac{1}{8}\text{'}$ (28.6 mm) from the face of the orifice to the back of the manifold pipe (Fig. 3). Make sure orifice is installed straight so that it forms a right angle (90°) to the manifold.

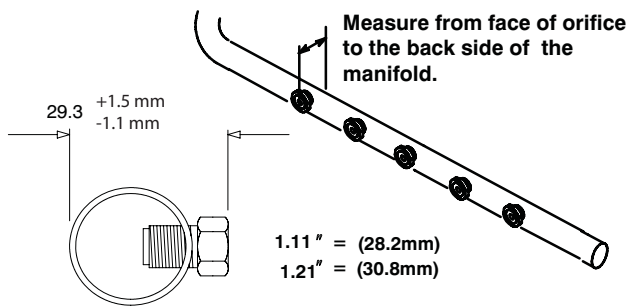

Fig. 3 - Changing Orifices

A07840

installation at altitudes up to 2,000' (610 M). The #54 burner orifices supplied in this kit are sized for propane gas at full rate only, for use between 0-2000' (610 M) elevation. Do not use them with butane or a mixture of butane and propane, or at elevations above 2000' (610 M) (except when noted by **Table 1**)

In the USA, the input rating for altitudes above 2000' must be reduced by 4% for each 1000' (305 M) above sea level (see **Table 1**). In Canada, the input rating for altitudes above 2000' (610 M) must be reduced by 10% for altitudes of 2000' (610 M) to 4500' (1372 M) above sea level. Use the 2001 to 3000 (610 M to 914 M) column in **Table 1**. Orifices for conversion at high altitude are included in this kit.

High Altitude Installation

These units may be installed at full input rating when installed at altitudes up to 2000'. Gas input rate on furnace rating plate is for

MANIFOLD PRESSURE AND ORIFICE SIZE FOR HIGH ALTITUDE APPLICATIONS

PROPANE GAS MANIFOLD PRESSURE (IN W.C.)														
HEATING VALUE at ALTITUDE BTU/CU. FT.	MEAN ELEVATION FEET ABOVE SEA LEVEL													
	0 to 2000		2001 to 3000		3001 to 3999		4001 to 5000		5001 to 6000		6001 to 7000		7001 to 8000	
	Hi	Lo	Hi	Lo	Hi	Lo	Hi	Lo	Hi	Lo	Hi	Lo	Hi	Lo
2500	10.0	4.9	10.0	4.9	9.0	4.4	10.0	4.9	9.4	4.6	8.5	4.2	10	4.9
Orifice Size	#54		#54		#54		#55		#55		#55		#56	

NOTE: Propane data is based on 1.53 specific gravity. For fuels with different specific gravity consult the National Fuel Gas Code ANSI Z223.1-2006/NFPA 54-2006 or National Standard of Canada, Natural Gas and Propane Installation Code CSA B149.1-05.

NOTE: Unshaded orifice size box indicates factory shipped size.

NOTE: In the USA, the input rating for altitudes above 2000' must be reduced by 4% for each 1000' above sea level (see Table 1)

In Canada, the input rating for altitudes above 2000' must be reduced by 10% for altitudes of 2000' to 4500' above sea level. Use the 2001 to 3000 column in Table 1.

Table 1 - Manifold Pressure and Orifice Size for High Altitude Applications

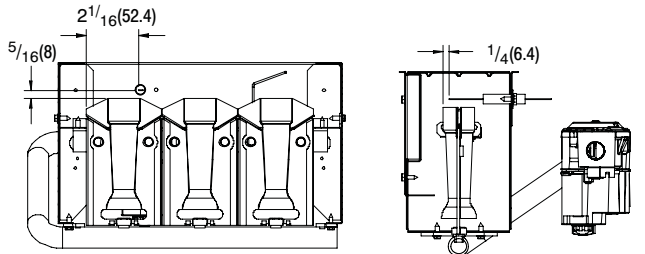

Fig. 4 - Igniter Location

A07735

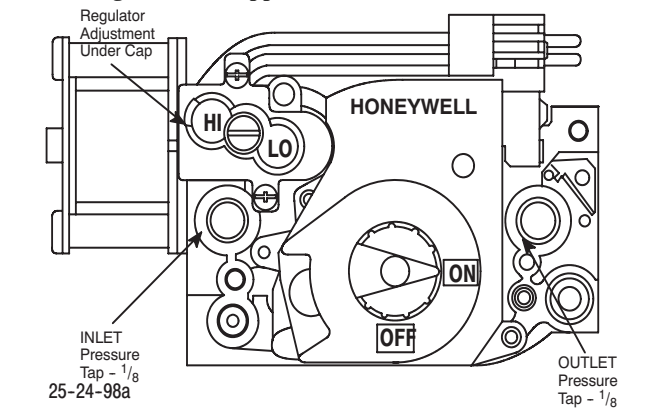

Fig. 5 - Honeywell Gas Valve VR8205Q

A07792

Gas Valve Conversion

Conversion of Honeywell VR8205Q Gas Valve using Natural Gas Conversion Kit #396021.

1. Remove the two screws securing the Hi/Lo regulator cover to the valve. (See Fig. 5 & Fig. 6)
2. Remove the existing regulator spring plunger (white color) from the regulator housing.
3. Insert the replacement spring plunger (black color) contained in this kit into regulator housing with the spring end down.
4. Replace the Hi/Lo regulator cover and secure with the two screws.
5. Attach the Caution Label contained in the kit to the Gas Valve where it can be readily seen.

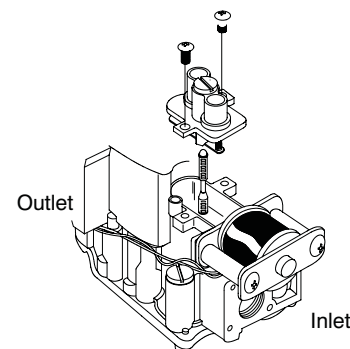
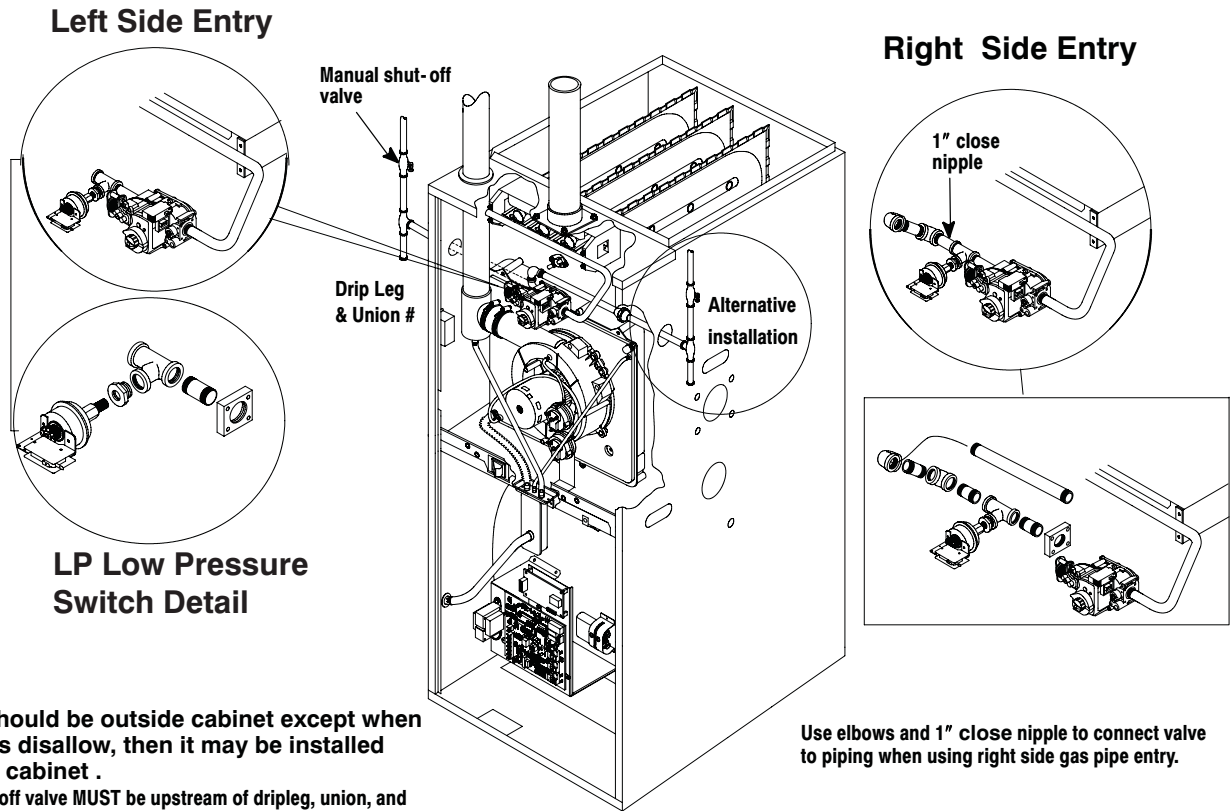

Fig. 6 - Typical Honeywell Regulator Assembly

A07841



Union should be outside cabinet except when clearances disallow, then it may be installed inside the cabinet .
Manual shut-off valve MUST be upstream of dripleg, union, and furnace.

Use elbows and 1" close nipple to connect valve to piping when using right side gas pipe entry.

Fig. 7 - Typical Gas Piping and Adding Propane Low Pressure Switch

A07842

Propane Low Pressure Switch (Required)

1. Install the inlet fitting adapter #1147904 to the inlet of the gas valve using the O-ring and the four screws provided with the kit. Tighten securely.
2. Using pipe joint compound that is resistant to Propane gas, tighten the fitting assembly into the inlet side of the gas valve. (Fig. 7). Position fitting assembly as shown.
3. Screw the Propane pressure switch into the bushing. Use pipe dope on connection. Tighten securely.

NOTE: Do not block inlet port of pressure switch with pipe dope. Switch will not operate if inlet port is blocked.

4. Remove one yellow wire from the low fire pressure switch. Connect this wire to the male insulated yellow wire in the wire harness provided.(See Fig. 7).
5. Connect the other yellow wire in the harness to the open termination on the Low Fire pressure switch.
6. Connect the other end of the wire harness to the two terminals on the Propane switch.

NOTE: Propane switch is factory set to open if Propane gas supply pressure falls below 6 in w.c.

NOTE: See Furnace Wiring Label.

Reassembly

Reassemble all parts in reverse order as removed. Attach Propane Conversion Label to the front exterior of the furnace.

- **Manifold Assembly** - Be sure to engage the main burner orifices in the proper openings in the burners.
- Verify the igniter is in the correct location. (See **Figure 5**)
- **Testing for leaks** - After reassembly, turn the gas on and check all joints for gas leaks using a soapy solution. All leaks must be repaired immediately.

Gas Pressure

- Refer to the furnace rating plate for the approved gas input ratings.
- Gas input to burners **MUST NOT** exceed the rated input shown on rating plate.
- **Do NOT** allow minimum gas supply pressure to vary downward. Doing so will decrease input to furnace. Refer to **Table 2** for gas supply and manifold pressures.

Gas Pressures					
Gas Type	Supply Pressure			Manifold Pressure	
	Recommended	Max.	Min.	Hi Fire	Lo Fire
Propane	11 in w.c.	14 in w.c.	11 in w.c.	10 in w.c. *	4.9 in w.c. *

***SEE TABLE 1**

Important Notes

- **With Propane gas, the rated input is obtained when the BTU content is 2,500 BTU per cubic foot and manifold pressure set at 10 inches W.C.**
- **If Propane gas has a different BTU content, orifices MUST be changed by licensed Propane installer.**
- **Measured input can NOT exceed rated input.**
- **Any major change in gas flow requires changing burner orifice size.**

Start-up and Check-out

1. Remove the plug from the Inlet Pressure Tap on gas valve and install a manometer. (Fig. 5)
2. Open manual gas line valve to unit. Check for gas leaks and correct as necessary. Check supply pressure, 11 in wc recommended, (11 in wc minimum, 14 in wc maximum). If not within these limitations DO NOT OPERATE FURNACE, contact gas supplier.
3. Close manual gas line valve to unit, remove manometer and replace inlet pressure tap plug.

Manifold Gas Pressure Adjustments (Hi & Lo Fire)

NOTE: Gas supply pressure **MUST** be within minimum and maximum values listed on rating plate. Pressures are usually set by gas suppliers.

Make adjustment to manifold pressure with burners operating.

1. Connect U-Tube manometer to the tapped opening on the outlet side of gas valve on the manifold pipe. (See Fig. 5) Use a manometer with a 0 to 12" minimum water column range.
2. Turn gas **ON**. Operate the furnace on high fire by using a jumper wire on the R to W1 & W2 thermostat connections on the fan board.
3. Remove the adjustment screw covers on the gas valve. Turn counterclockwise to decrease the manifold pressure and clockwise to increase.
4. Set the manifold pressure to value shown in Table 1.
5. Operate the furnace on low fire by using a jumper wire on the R to W1 thermostat connections on the fan board.

NOTE: The third (3rd) DIP switch on furnace control board should be in the on position to set the low fire manifold pressure. (See wiring diagram)

6. Repeat steps 3 and 4 for low fire operation.
7. When the manifold pressures are properly set, replace the adjustment screw covers on the gas valve. Remove manometer and replace plug.
8. Remove the jumper wires from the thermostat connections on the fan board.
9. Return third (3rd) DIP switch to correct setting.
10. Start the main burners and check pressure tap plug for gas leaks.
11. With gas valve on, observe furnace through two or more complete cycles to be sure all controls are operating.
12. Turn gas valve to OFF. Remove the pressure gauge and replace the pressure tap plug and pressure regulator cap screw.

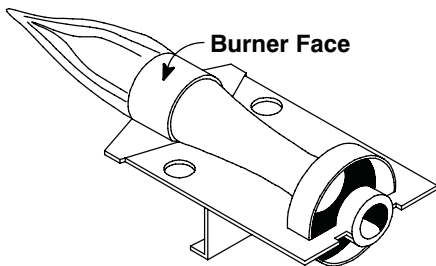

Fig. 8 - Main Burner

A07734

Checking Input Rate

***High Altitude Input Rate =
Nameplate Sea Level Input Rate x (Multiplier)**

Elevation	High Altitude Multiplier Propane Gas*
0' - 2000' (0 - 610 M)	1.00
2001' - 3000' (610 - 914 M)	0.90
3001' - 4000' (914 - 1219 M)	0.86
4001' - 5000' (1219 - 1524 M)	0.82
5001' - 6000' (1524 - 1829 M)	0.78
6001' - 7000' (1829 - 2134 M)	0.74
7001' - 8000' (2134 - 2438 M)	0.70

* Based on mid-range of elevation.

Table 2 - Input Rate Multiplier

Main Burner Flame Check

Check for the following: (See Fig. 8)

- Stable and blue flames. Dust may cause orange tips or wisps of yellow, but flames **MUST NOT** have solid, yellow tips.
- Flames extending directly from burner into heat exchanger.
- Flames do **NOT** touch sides of heat exchanger

If any problems with main burner flames are noted, it may be necessary to adjust gas pressures or check for drafts.

High Altitude Derate Label

The derate label supplied with the conversion kit must be completed and affixed to the furnace near the rating plate. Fill in the manifold pressure, orifice size and revised input rate. The revised input rate is determined in the following manner:

Refer to Table 1 provided to determine the proper orifice part numbers.

Verify System Operation

Upon completion of all conversion procedures, perform the following steps to attach the appropriate labels and verify the system operation.

1. Locate the Propane Gas Conversion Label next to the furnace rating plate.
2. Fill out and attach the Field Conversion Label to the front exterior of the furnace.
3. Turn the thermostat to its lowest temperature setting or to OFF if equipped with a System Select Switch.
4. Turn the gas valve control knob to ON.
5. Reinstall all access panels.
6. Turn ON all electrical power to the unit.
7. Set the thermostat to the desired temperature and the System Select Switch to HEAT.
8. Observe unit operation through two (2) complete heating cycles. See "Sequence of Operation" in furnace installation instructions.

