

# Model 76CR Dehumidifier Control Installation Instructions

## READ AND SAVE THESE INSTRUCTIONS

The Model 76CR is for use with DEHCRDA1070 and DEHCRDA1095 dehumidifiers as an **EXTERNAL CONTROL** or **REMOTE CONTROL**.

(See **OVERVIEW** on page 3 for details.)

## SAFETY INSTRUCTIONS

### **WARNING**

1. Improper installation may cause property damage or injury. Installation, service, and maintenance must be performed by a qualified service technician.
2. 120 Volts may cause serious injury from electric shock. Disconnect electrical power before starting installation or servicing. Leave power disconnected until installation/service is completed. This control is not a 120 Volt (line voltage) device.

### **CAUTION**

1. Read all instructions before beginning installation.
2. Do not use in pool applications. Pool chemicals can damage the control.
3. Do not use solvents or cleaners on or near the display and circuit board. Chemicals can damage components.

## TABLE OF CONTENTS

<b>Safety Instructions</b> .....	1
<b>Overview</b> .....	3
<b>Specifications</b> .....	3
<b>Location Recommendations</b> .....	4
<b>Installation</b>	
Mount Control .....	5
Wiring	
External Control .....	7
Remote Control .....	9
<b>System Checkout</b>	
Power Up .....	11
Test Mode .....	13
Humidity/Dryness Level Setting .....	13
Offset .....	13
Turning On and Setting the Control	
External Control .....	14
Remote Control .....	14
Sequence of Operation	
External Control .....	15
Remote Control .....	15
<b>Troubleshooting</b>	
Error Codes	
External Control .....	16
Remote Control .....	16
Troubleshooting Guide .....	19

## OVERVIEW

The Model 76CR Dehumidifier Control provides control of the dehumidifier from the living space.

The control can be installed as an EXTERNAL CONTROL, allowing the homeowner to set and adjust the humidity setting and turn dehumidification on or off from a convenient location. In this application, the Model 76CR uses an onboard sensor to monitor the relative humidity (%RH) in the space in which it is located and displays the measured relative humidity on the digital display.

The control can also be installed to function as a REMOTE CONTROL if the dehumidifier is located where it is not easy or convenient to access. The control can be installed in any location within the living space, with the dehumidifier installed in the area to be dehumidified, such as a crawl space, sealed attic, or basement. The dryness level is set on the control and communicated to the dehumidifier. The dehumidifier communicates the measured relative humidity in the space being dehumidified back to the Model 76CR Control where it is displayed on the digital display.

## SPECIFICATIONS

ELECTRICAL	External	Remote
Input Voltage and Current	Voltage: 24VAC +/-20% Current: 25mA (nominal), 50mA (max.) at 24VAC	Voltage: 9VDC (supplied by dehumidifier control board)
Output	Dry Contact, Normally Open	Communication

CONTROL	External	Remote
Control Range	40% – 80% RH	1 (less dry) – 7 (more dry) 65°F – 40°F Dew Point
Accuracy	+/-5% RH	See Dehumidifier Specifications
Differential	3%	
Low Limit	40°F Dew Point	50°F Dry Bulb
High Limit	99°F Dry Bulb	105°F Dry Bulb

## LOCATION RECOMMENDATIONS

As a REMOTE CONTROL, the Model 76CR can be mounted wherever is convenient for the homeowner.

Follow the recommendations below when installing the Model 76CR as an EXTERNAL CONTROL.

### MOUNT CONTROL

- In an area the homeowner wants to monitor and control moisture levels.
- On an interior wall.
- Approximately 5' off the floor.
- At least 18" from an outside wall.

### DO NOT MOUNT CONTROL

- **In the flow of a supply register.**
- Behind doors, in corners or other dead air spaces.
- In direct sunlight, near lighting fixtures, or other appliances that give off heat.
- On an outside or unconditioned area wall.
- In stairwells or near outside doors.
- On a wall with concealed pipes or ductwork.

FIGURE 1 – Mounting Control

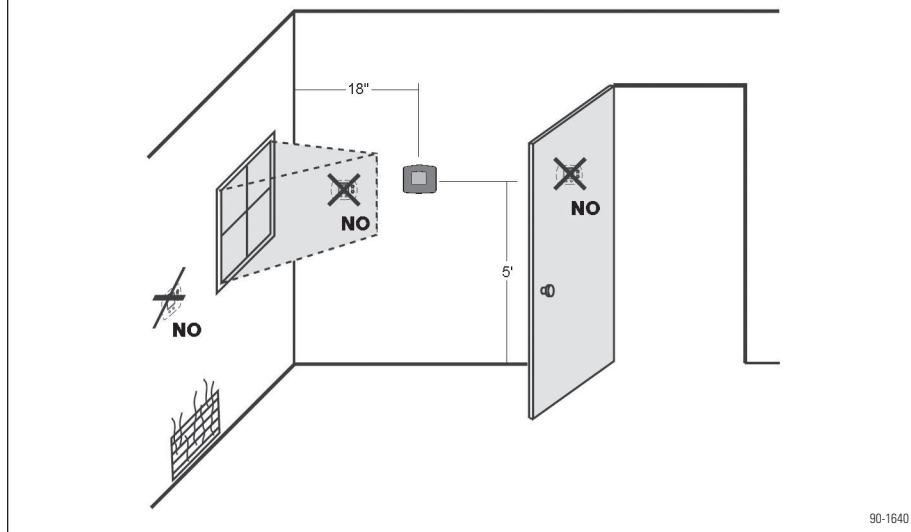

90-1640

## INSTALLATION

### MOUNT CONTROL

FIGURE 2 – Disassemble Control

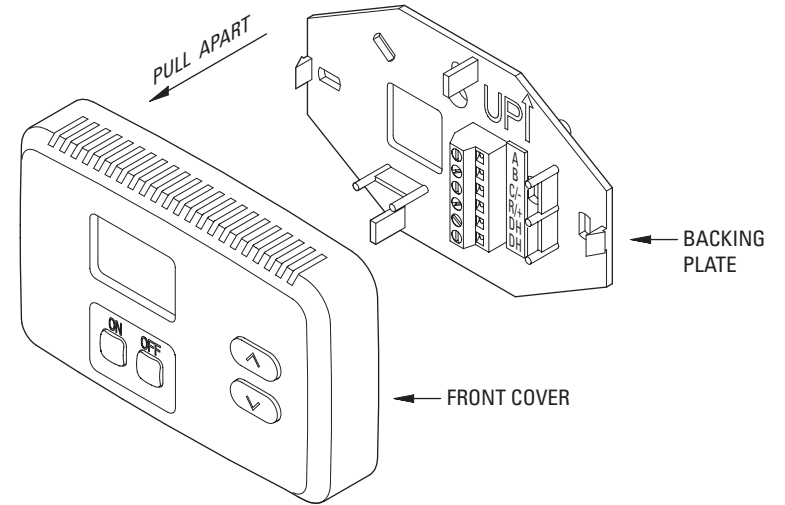

90-1631

FIGURE 3 – Mount Backing Plate

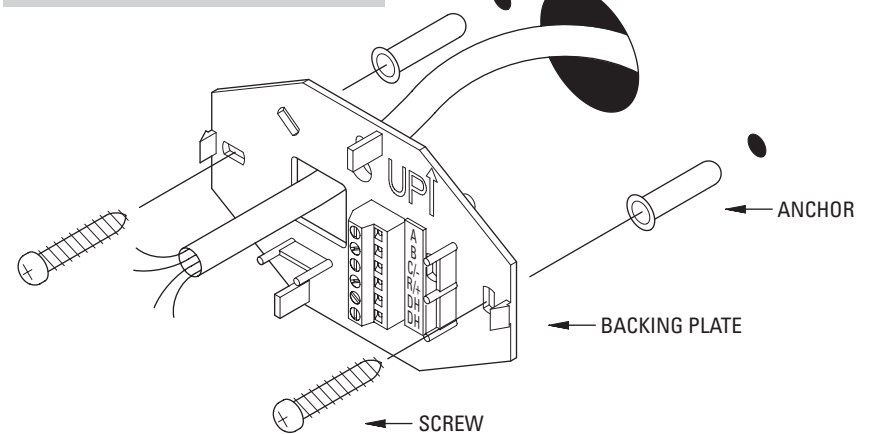

90-1632

## REQUIRED COMPONENTS

- 18 – 24 gauge wire (field supplied) – 4 wires required, run new cable as needed.
- (2) #8 x 1-1/2" mounting screws (supplied)
- (2) Anchors (supplied)

1. Level the backing plate on the wall and mark the mounting holes and wire access location on the wall.
2. Drill two 3/16" mounting holes and a 3/4" wire access hole. See **Figure 3**.
3. Install the drywall anchors flush with the wall surface. **Note:** Mounting holes on the backing plate are designed to fit on a horizontal J-box.
4. Run a 4-wire cable from the dehumidifier to the wall mount location and through the square hole in the backing plate.
5. Secure the backing plate to the wall using the two #8 x 1-1/2" screws.

## WIRING

### MODEL 76CR EXTERNAL CONTROL

1. **Disconnect power to the dehumidifier and HVAC system.**
2. Remove the wiring access cover next to the control on the dehumidifier. See **Figure 4**.
3. Wire the Model 76CR to the dehumidifier as shown in **Figure 5**.
4. Ensure the NO/NC switch on the dehumidifier control is set to NO (see **Figure 5**).

**FIGURE 4 – Wiring Access Cover Location**

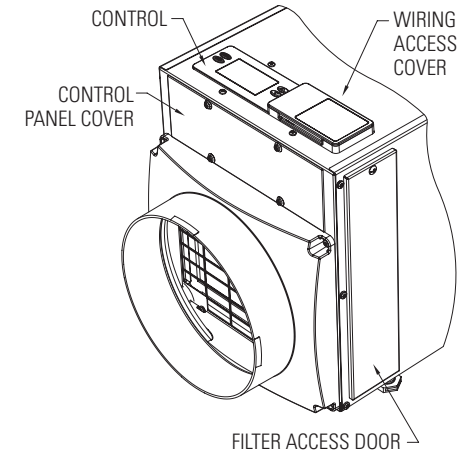

90-1884

**FIGURE 5 – Model 76CR External Control Wiring**

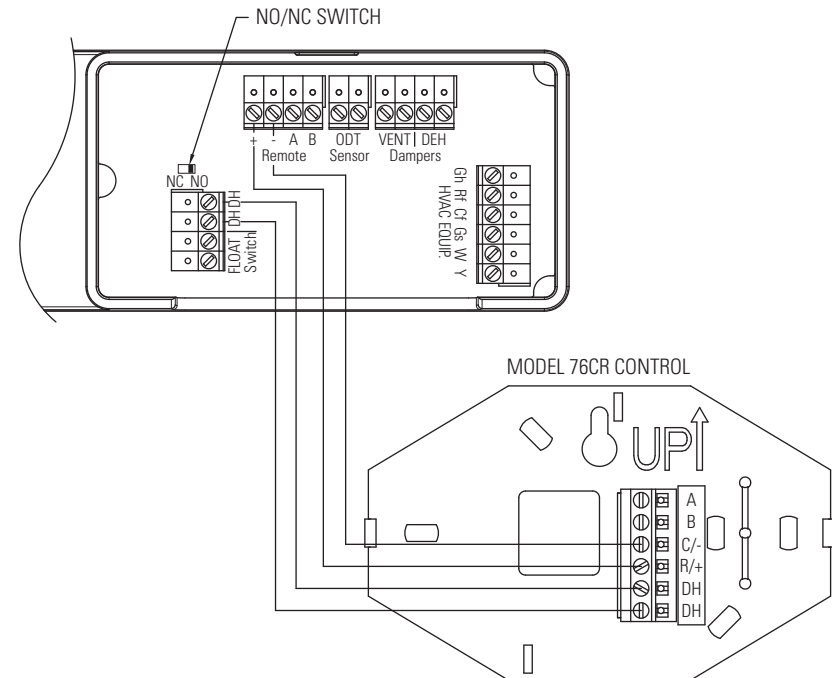

90-1862

5. Snap the wiring access cover back into place, power up the dehumidifier and use the ON/OFF button to turn the unit OFF (if ON).

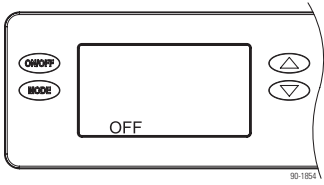

6. Press and hold the MODE button for 3 seconds to enter the Installer Set Up menu – “REMOTE DISABLED” will appear on the display when Installer Set Up is entered.
7. Repeatedly press the MODE button until “EXTERNAL DISABLED” shows on the display.
8. Press the UP or DOWN button to change to “EXTERNAL ENABLED”.

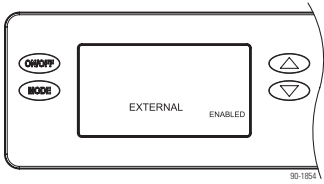

9. Repeatedly press the MODE button until “DONE” appears on the display.

## MODEL 76CR REMOTE CONTROL

1. Disconnect power to the dehumidifier and HVAC system.
2. Remove the wiring access cover next to the control on the dehumidifier. See **Figure 6**.
3. Wire the Model 76CR to the dehumidifier as shown in **Figure 7**.

**FIGURE 6 – Wiring Access Cover Location**

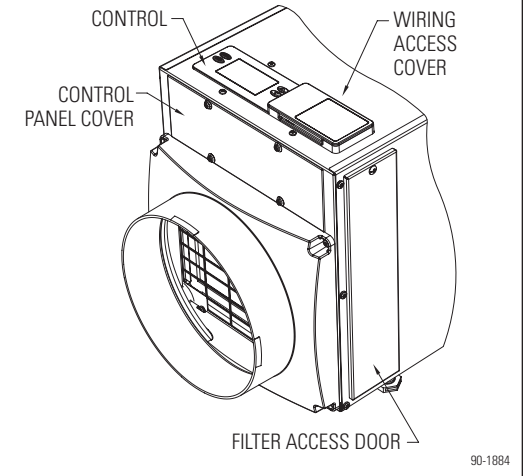

**FIGURE 7 – Model 76CR Remote Control Wiring**

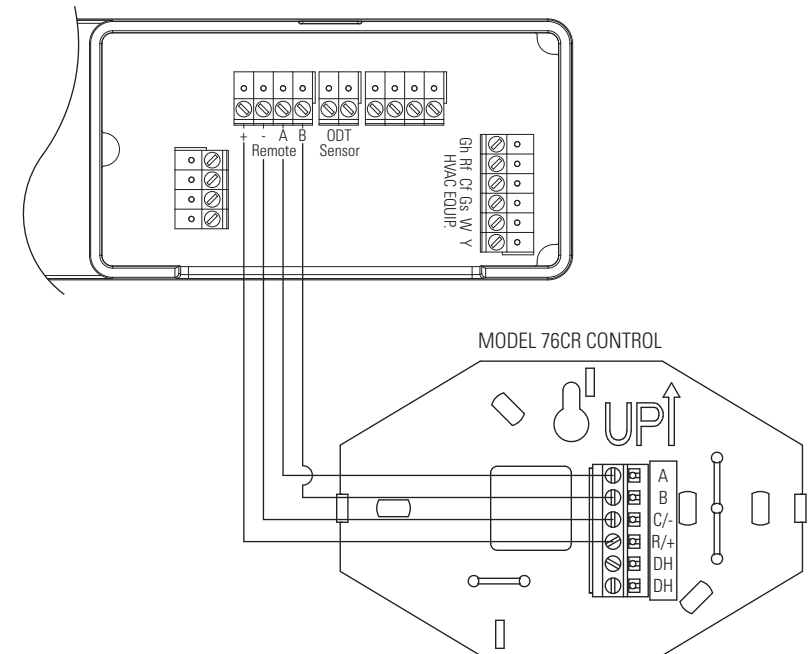

4. Snap the wiring access cover back into place, power up the dehumidifier and use the ON/OFF button to turn the unit OFF (if ON).

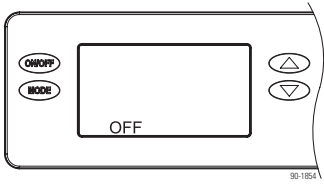

5. Press and hold the MODE button for 3 seconds to enter the Installer Set Up menu – “REMOTE DISABLED” will appear on the display when Installer Set Up is entered.

6. Press the UP or DOWN button to change to “REMOTE ENABLED”.

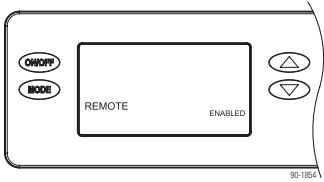

7. Press the MODE button and “DONE” will appear on the display.

## SYSTEM CHECKOUT

### POWER UP

1. Check all wiring.
2. Plug in dehumidifier and restore power to the HVAC system.
3. Turn on/off switch on dehumidifier ON. After a 4 second start up sequence all buttons on the Model 76CR will be functional.
  - The control will be OFF.
  - The humidity setting will be 60% if wired for EXTERNAL CONTROL. The dryness level will be set to 3 if REMOTE CONTROL.
  - The control will display the measured humidity.
    - EXTERNAL CONTROL displays humidity measured by the **control** in it's installed space.
    - REMOTE CONTROL displays humidity measured by the **dehumidifier** in it's installed space.

**FIGURE 8 – External Control**

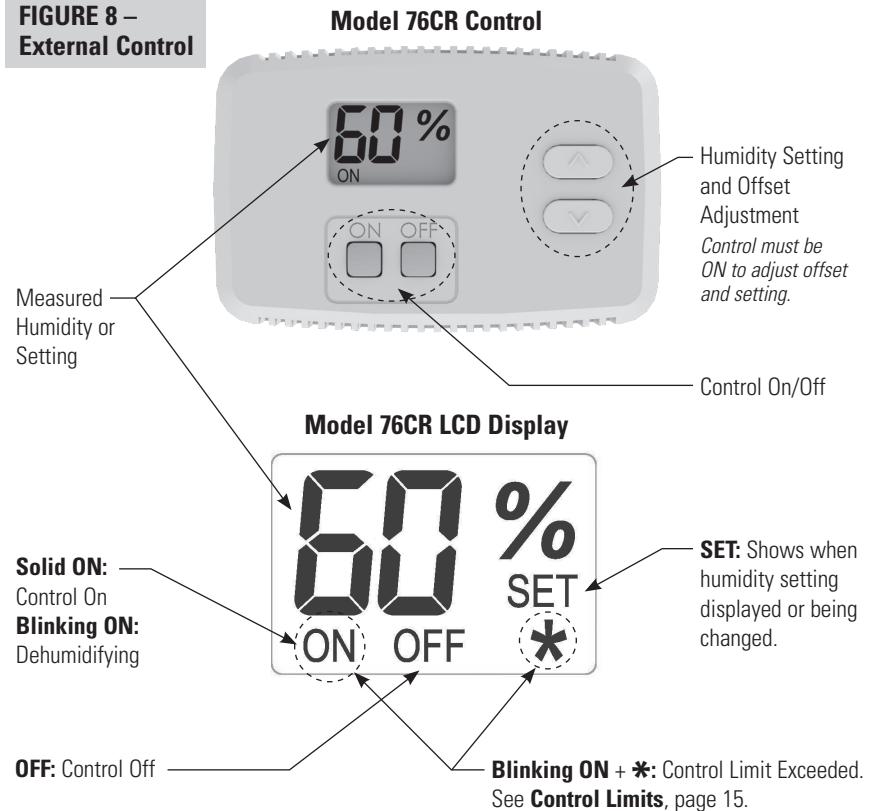

90-1636

**FIGURE 9 – Remote Control**

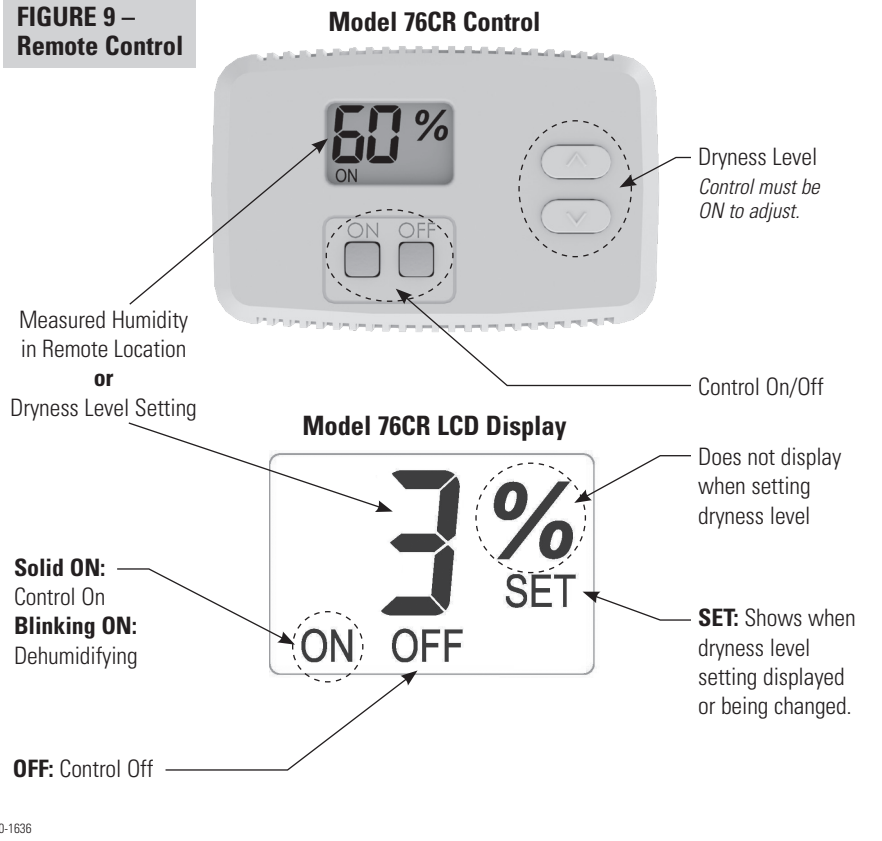

## TEST MODE

- Press and hold the ON button for 5 seconds to enter Test Mode.
  - Verify the measured humidity is displayed on the Model 76CR screen.
  - Verify dehumidifier turns on, and **ON** blinks on the Model 76CR screen.
  - Verify the \* is displayed on the Model 76CR screen when wired as a REMOTE CONTROL.
- After 5 minutes or after pressing the OFF button, the control will enter Off mode.
  - Verify the dehumidifier turns off.

## HUMIDITY/DRYNESS LEVEL SETTING

- The control must be ON to adjust the humidity or dryness level setting.
- The ▲ (up) and ▼ (down) buttons are used to increase or decrease the setting.
- The first press of either button will display the current setting and **SET** on the LCD display.
- Each subsequent push of the up or down buttons will change the setting by 1% or 1 dryness level.
- If a button is held down, the setting will continually change by 1% or 1 dryness level every 1/2 second for as long as the button is pressed.
- The control will return to Normal Mode, displaying the measured humidity, 5 seconds after the last button press/release.

## OFFSET

When the Model 76CR is installed as an EXTERNAL CONTROL, an offset can be applied to the humidity reading to avoid discrepancies with other humidity measuring devices in the home. Allow 48 hours for the control to acclimate before applying an offset. The control must be ON to enter the Offset screen.

**NOTE:** This feature is not available when the control is installed as a REMOTE CONTROL.

- Press and hold the OFF button for 5 seconds to enter the Offset screen.
- The ▲▼ buttons can be used to set an offset value between -5% RH and +5% RH.
- The control will return to Normal Mode, displaying the measured humidity, 5 seconds after the last button press/release.

**FIGURE 10 – Offset Screen**



## TURNING ON AND SETTING THE CONTROL

### EXTERNAL CONTROL

1. Press the ON button.
2. Use the ▲▼ buttons to set the control at 59%.
  - ▲ Increasing the humidity setting will decrease dehumidifier run time, allowing for higher humidity levels.
  - ▼ Decreasing the humidity setting will increase dehumidifier run time, allowing for lower humidity levels.

### REMOTE CONTROL

1. Press the ON button.
2. Use the ▲▼ buttons to set the control to a 3 dryness level.
  - ▲ Increasing the dryness level will increase dehumidifier run time, allowing for lower humidity levels.
  - ▼ Decreasing the dryness level will decrease dehumidifier run time, allowing for higher humidity levels.

The dryness level settings can be approximated to relative humidity (%RH) using **Table 1**.

Dryness Level Setting	Indoor Temperature (°F)			
	65	70	75	80
1		84%	71%	60%
2	86%	73%	61%	52%
3	74%	63%	53%	45%
4	64%	54%	45%	39%
5	55%	46%	39%	33%
6	47%	39%	33%	28%
7	40%	34%	28%	24%

**Note:** This table is for reference only.

## SEQUENCE OF OPERATION

### EXTERNAL CONTROL

#### Normal Mode

- When the measured humidity is greater than the setting, the control will activate the dehumidifier output, the dehumidifier will begin dehumidifying and ON will blink on the LCD display.
- When the measured humidity falls 3% below the setting, the control will deactivate the dehumidifier output, the dehumidifier will stop dehumidifying and the LCD will display a solid ON.

#### Control Limits

- If the control measures a dew point below 40°F OR a temperature above 99°F, the control will deactivate the dehumidifier output if actively dehumidifying, the dehumidifier will stop dehumidifying, and **ON** and ✱ will blink on the LCD screen.
- The control will resume normal operation when the measured dew point is greater than 45°F or the measured temperature is below 94°F, whichever control limit was exceeded.

### REMOTE CONTROL

#### Normal Mode

- Once during every Cycle Period the dehumidifier blower and dehumidifier damper output will turn on and sample the air in the area served by the dehumidifier. Sampling will also occur whenever the dryness level setting is increased on the Model 76CR Control.
- After three minutes, the dew point of the incoming air is measured and compared to the dryness level set on the Model 76CR Control. If the dew point of the incoming air is above the setting, the compressor turns on and ON will flash on the Model 76CR screen.
- The dew point of the incoming air is continuously monitored during compressor operation. When the dew point of the incoming air falls below the dryness level setting, the dehumidifier compressor and blower will turn off and ON will stop flashing on the Model 76CR screen.

#### Control Limits

The control limits are determined by the dehumidifier.

- If the dehumidifier senses incoming air below 50°F or above 105°F, the dehumidifier will stop compressor operation if actively dehumidifying and ON will stop flashing on the Model 76CR screen.
- The dehumidifier will resume normal operation when the measured incoming air to the dehumidifier is between 55°F and 100°F.



## TROUBLESHOOTING

Use the guide on the following page to help find and correct system faults. Contact Technical Support before replacing the control or for additional troubleshooting.

### ERROR CODES

#### EXTERNAL CONTROL

When the control detects an internal error, it will stop controlling, deactivate the dehumidifier output, and the LCD will display the Error Code. See **Figure 11**. The control will attempt to recover from the error every 10 minutes. The Error Code will continue to be displayed as long as the error condition exists. Button presses are not registered when in Error Mode. Cycling power to the control will not clear the code and the control will need to be replaced.

**FIGURE 11 – External Control Error Code Screen**

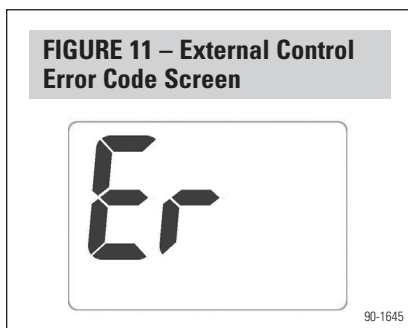

#### REMOTE CONTROL

When there is a dehumidifier or control communication fault, all dehumidifier outputs will turn off and the Model 76CR LCD will display an Error Code. See **Figure 12** for an example. The faults can either be critical or non-critical. Any fault will result in all dehumidification outputs turning off. A critical fault is cleared by repairing the fault and cycling power using the on/off switch on the dehumidifier. A non-critical fault is cleared by repairing the fault and cycling power to the dehumidifier is not required. See **Table 2** for the error codes and required action.

**FIGURE 12 – Remote Control Error Code Screen**

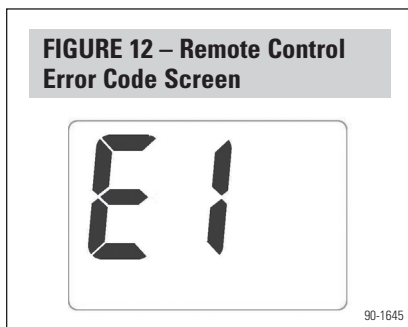

**TABLE 2 – Error Codes**

Error Code	Failure Mode	Action	Reset
E1	Internal Humidity or Temperature Sensor Open or Shorted	<ol style="list-style-type: none"> <li>1. Check the connection between the sensor board and control board.</li> <li>2. If connection okay, replace sensor board, Part No. 5488.</li> </ol>	Cycle Power
E2	High Refrigeration Pressure	<ol style="list-style-type: none"> <li>1. Verify that the fan works, the backflow damper swings freely and there is no blocked or restricted ductwork.</li> </ol>	Cycle Power
E3	Model 76CR Remote Control Communication Loss	<ol style="list-style-type: none"> <li>1. Check connections between Model 76CR and dehumidifier control board. Terminals should be fully inserted and secured in the control board and Model 76CR control terminals.</li> <li>2. If connections are correct and secure, turn off the dehumidifier and remove the Model 76CR. Use a short section of 4-wire cable to reconnect the Model 76CR to the control board. Turn the dehumidifier back on and increase the dryness level setting on the Model 76CR. If the dehumidifier turns on, the problem is with the wiring between the dehumidifier and control.</li> </ol>	Self-Correcting
E4	Insufficient Capacity	<ol style="list-style-type: none"> <li>1. Check the frost sensor connection at the power board. Terminal should be fully seated on the power board pins.</li> <li>2. Remove the side access panel and verify that the sensor is secured to the suction line.</li> <li>3. If the sensor is connected and secured to the refrigeration line proceed to the next step.</li> <li>4. Reset the fault by cycling power to the dehumidifier.</li> <li>5. Turn the humidity setting down (below room/home humidity level) to make a dehumidification call.</li> <li>6. Allow the fan and compressor to run for approximately 10-15 minutes and then enter diagnostic test mode by simultaneously pressing the UP ARROW and MODE buttons for 3 seconds. The LCD will display the temperature measured by the internal sensor while also displaying AIR SAMPLING and ON, the humidity measured by the internal sensor while also displaying %RH and ON, and the frost sensor temperature while also displaying ON. Scroll through these values and by using the UP/DOWN arrow buttons.</li> </ol>	Cycle Power

<b>Error Code</b>	<b>Failure Mode</b>	<b>Action</b>	<b>Reset</b>														
E5	High Temperature Thermistor Failure	<ol style="list-style-type: none"> <li>1. Check the high temperature sensor connection at the power board. Terminal should be fully seated on the power board pins.</li> <li>2. Remove the side access panel and verify the sensor is not damaged and connected to the refrigeration line coming from the compressor.</li> <li>3. If the sensor is connected and secured to the refrigeration line, it may need to be replaced with Part No. 5485.</li> </ol>	Cycle Power														
E6	Low Temperature Thermistor Failure	<ol style="list-style-type: none"> <li>1. Check the low temperature sensor connection at the power board.</li> <li>2. Remove the side access panel and verify the sensor is not damaged and connected to the suction line.</li> <li>3. If the sensor is connected and secured to the refrigeration line, it may need to be replaced with Part No. 5483.</li> </ol>	Cycle Power														
E7	Float Switch Open	<ol style="list-style-type: none"> <li>1. Empty the condensate pan.</li> <li>2. Check the float switch connection at the control board.</li> <li>3. If not using a float switch, verify jumper is between float switch terminals on dehumidifier control board.</li> <li>4. If the problem persists, replace the float switch.</li> </ol>	Self-Correcting														
E8	Inlet Air Temperature Out of 50°F – 104°F or dew point below 40°F	<ol style="list-style-type: none"> <li>1. Verify all ductwork is properly sealed.</li> </ol>	Self-Correcting														
E9	Outdoor Temperature Sensor Open or Shorted	<ol style="list-style-type: none"> <li>1. Check the sensor connection at the power board.</li> <li>2. Remove the wires from the terminals and measure the resistance. An short circuit will have a resistance very close to 0 Ohms and an open circuit will have a very very high resistance. The table below can be used to approximate the resistance based on outdoor temperature. <table border="1" data-bbox="405 1219 787 1458"> <thead> <tr> <th><b>Outdoor Temperature</b></th> <th><b>Resistance</b></th> </tr> </thead> <tbody> <tr> <td>0°F</td> <td>84,500 Ohms</td> </tr> <tr> <td>20°F</td> <td>46,000 Ohms</td> </tr> <tr> <td>40°F</td> <td>26,000 Ohms</td> </tr> <tr> <td>60°F</td> <td>15,500 Ohms</td> </tr> <tr> <td>80°F</td> <td>9,500 Ohms</td> </tr> <tr> <td>100°F</td> <td>6,000 Ohms</td> </tr> </tbody> </table> </li> <li>3. If the sensor is not reading correctly, replace the sensor, Part No. 4401.</li> </ol>	<b>Outdoor Temperature</b>	<b>Resistance</b>	0°F	84,500 Ohms	20°F	46,000 Ohms	40°F	26,000 Ohms	60°F	15,500 Ohms	80°F	9,500 Ohms	100°F	6,000 Ohms	Self-Correcting
<b>Outdoor Temperature</b>	<b>Resistance</b>																
0°F	84,500 Ohms																
20°F	46,000 Ohms																
40°F	26,000 Ohms																
60°F	15,500 Ohms																
80°F	9,500 Ohms																
100°F	6,000 Ohms																

<b>Symptom</b>	<b>Possible Reason</b>	<b>Troubleshooting Procedure</b>
No power to the control.	Incorrect wiring.	Verify wiring connections between control, dehumidifier and HVAC system (where applicable).
	No power to dehumidifier.	<ul style="list-style-type: none"> <li>• Verify that the dehumidifier power switch is ON.</li> <li>• Verify the circuit breaker has not tripped.</li> </ul>
	No power to HVAC equipment.	<ul style="list-style-type: none"> <li>• Verify HVAC system switch is on.</li> <li>• Verify the circuit breaker has not tripped.</li> </ul>
Control does not turn on dehumidifier output.	Incorrect wiring.	Verify wiring connections between control and dehumidifier.
Blank display or missing segments during Test mode.	LCD error.	Replace control.
Display shows Er.	Control detected an internal error.	The control will need to be replaced.
Display shows E1-E9.	Dehumidifier or communication error.	Use <b>Table 2</b> to troubleshoot fault.
Inaccurate humidity reading when using <b>External Control</b> .	Control recently installed after being stored in an uncontrolled temperature and humidity environment.	Allow 48 hours for control to acclimate.
	Offset has been applied to the humidity reading.	Change the offset.
	Control is mounted in direct sunlight, above a heat or humidity source, or in the path of a supply register.	Relocate the control.

