

# Installation and Start-Up Instructions

Electric  
Air Conditioner

AA1A

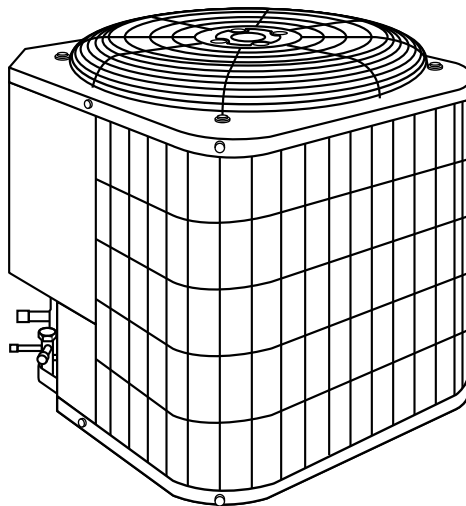

Fig. 1—Model AA1A

A91137

**NOTE:** Read the entire instruction manual before starting the installation.

## SAFETY CONSIDERATIONS

Improper installation, adjustment, alteration, service, maintenance, or use can cause explosion, fire, electrical shock or other conditions which may cause personal injury or property damage. Consult a qualified installer, service agency, or your distributor or branch for information or assistance. The qualified installer or agency must use factory-authorized kits or accessories when modifying this product. Refer to the individual instructions packaged with the kits or accessories when installing.

Follow all safety codes. Wear safety glasses and work gloves. Use quenching cloth for brazing operations. Have fire extinguisher available. Read these instructions thoroughly and follow all warning or cautions attached to the unit. Consult local building codes and National Electrical Code (NEC) for special requirements.

It is important to recognize safety information. This is the safety-alert symbol . When you see this symbol on the unit and in instructions or manuals, be alert to the potential for personal injury.

Understand the signal word— DANGER, WARNING, or CAUTION. These words are used with the safety-alert symbol. DANGER identifies the most serious hazards which **will** result in severe personal injury or death. WARNING signifies hazards that **could** result in personal injury or death. CAUTION is used to identify unsafe practices, which **would** result in minor personal injury or product and property damage.

---

 **WARNING:** Before installing or servicing system, always turn off main power to system. There may be more than 1 disconnect switch. Turn off accessory heater power if applicable. Electrical shock can cause personal injury or death.

---

## INSTALLATION

### PROCEDURE 1—CHECK EQUIPMENT AND JOBSITE

#### A. Unpack Unit

Move to final location. Remove carton taking care not to damage unit.

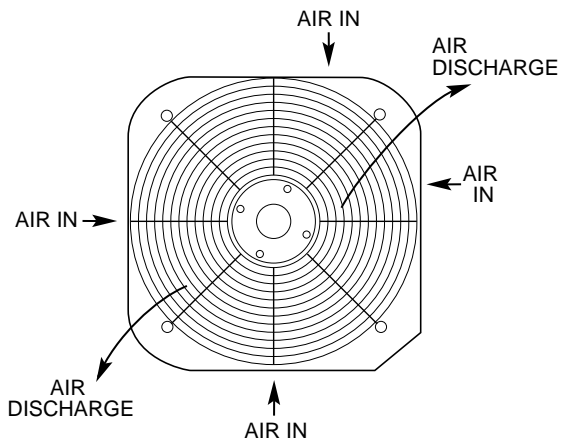

**NOTES:**

1. Allow 30 in. (762) clearance to service sides of unit, 48 in. (1219.2) above unit, 6 in. (152.4) on one side, 12 in. (304.8) on remaining side, and 24 in. (609.6) between units for proper airflow.
2. Minimum outdoor operating ambient in cooling mode is 55 F (12.8 C), max 115 F (46.1 C).
3. Dimensions in parenthesis are in millimeters.
4. Series designation is the 13th position of the unit model number.

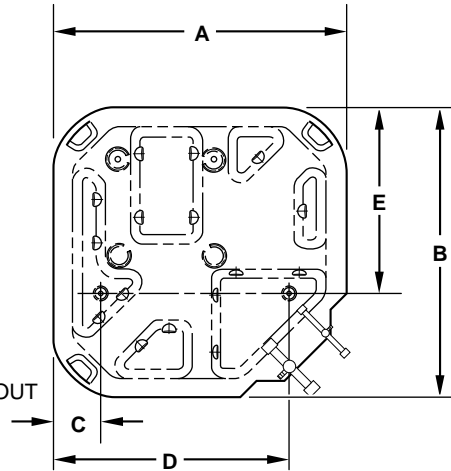
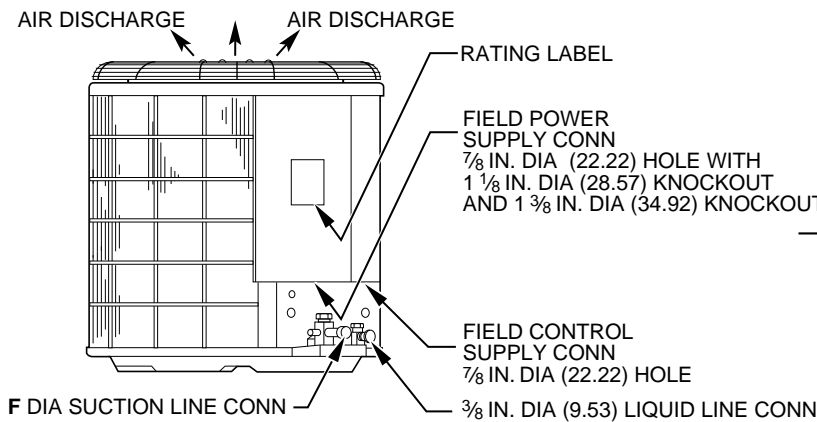

A91173

UNIT SIZE	A/B	C	D	E	F
	In.	In.	In.	In.	In.
018	22-1/2	3-11/16	18-1/8	14-3/8	5/8
024	22-1/2	3-11/16	18-1/8	14-3/8	5/8
030	22-1/2	3-11/16	18-1/8	14-3/8	3/4
036	22-1/2	3-11/16	18-1/8	14-3/8	3/4
042	30	6-1/2	23-1/2	20	7/8
048	30	6-1/2	23-1/2	20	7/8
060	30	6-1/2	23-1/2	20	7/8

**Fig. 2—Unit Reference Drawing**

**B. Inspect Equipment**

File claim with shipping company prior to installation if shipment is damaged or incomplete. Locate unit rating plate on unit service panel. (See Fig. 2.) It contains information needed to properly install unit. Check rating plate to be sure unit matches job specifications.

**PROCEDURE 2—INSTALL ON A SOLID, LEVEL MOUNTING PAD**

If conditions or local codes require the unit be attached to pad, tie-down bolts should be used and fastened through knockouts provided in unit base pan. Refer to unit mounting pattern in Fig. 2 to determine base pan size and knockout hole locations.

When installing, allow sufficient space for airflow clearance, wiring, refrigerant piping and service. Allow 30-in. (762mm) clearance to service end of unit and 48 in. (1219mm) above unit. For proper airflow, a 6-in. (52mm) clearance on 1 side of unit and 12 in. (305mm) on all remaining sides must be maintained. Maintain a distance of 24 in. (610mm) between units. Position so water, snow or ice from roof or eaves cannot fall directly on unit.

On rooftop applications, locate unit at least 6 in. (152mm) above roof surface. Place unit above a load-bearing wall and isolate unit and tubing set from structure.

Arrange supporting members to adequately support unit and minimize transmission of vibration to building. Consult local codes governing rooftop applications.

**PROCEDURE 3—REPLACE INDOOR CHECK-FLO-RATER® PISTON, IF REQUIRED**

Check indoor coil piston to see if it matches the required piston shown on unit rating plate. If it does not match, replace indoor coil piston with piston shipped with unit. The piston shipped with outdoor unit is correct for any approved indoor coil combination.

## PROCEDURE 4—MAKE PIPING CONNECTIONS

**⚠ CAUTION: DO NOT BURY MORE THAN 36 IN. (914mm) OF REFRIGERANT TUBING IN GROUND.** If any section of tubing is buried, there must be a 6-in. (152mm) vertical rise to the valve connections on the outdoor unit. If more than the recommended length is buried, refrigerant may migrate to cooler buried section during extended periods of unit shutdown, causing refrigerant slugging and possible compressor damage at start-up.

Outdoor units may be connected to indoor sections using accessory tubing package or field-supplied tubing of refrigerant grade, correct size, and condition. The liquid- and vapor-tube diameters can be determined by using Table 1. For tubing requirements beyond 50 ft (15.24m), consult your local distributor or the Long-Line Application Guideline.

**Table 1—Refrigerant Connections and Recommended Liquid- and Vapor-Tube Diameters (In.)**

UNIT SIZE	LIQUID		VAPOR	
	Conn Dia	Tube Dia	Conn Dia	Tube Dia
<b>018, 024</b>	3/8	3/8	5/8	5/8
<b>030, 036</b>	3/8	3/8	3/4	3/4
<b>042, 048</b>	3/8	3/8	7/8	7/8
<b>060</b>	3/8	3/8	7/8	1-1/8

Tube diameters are for lengths up to 50 ft. For tubing lengths greater than 50 ft, consult your local distributor or the Long-Line Application Guideline.

If either refrigerant tubing or indoor coil is exposed to atmospheric conditions for longer than 5 minutes, it must be evacuated to 1000 microns to eliminate contamination and moisture in the system.

Run refrigerant tubes as directly as possible, avoiding unnecessary turns and bends. Suspend refrigerant tubes so they do not damage insulation on vapor tube and do not transmit vibration to structure. Also, when passing refrigerant tubes through wall, seal opening so vibration is not transmitted to structure. Leave some slack in refrigerant tubes between structure and unit to absorb vibration.

### A. Outdoor units connected to factory-approved indoor units

Outdoor unit contains correct system refrigerant charge for operation with indoor unit of the same size when connected by 15 ft (4.57m) of field-supplied or factory accessory tubing. Check refrigerant charge for maximum efficiency. (See Procedure 9—Checking Charge.)

### B. Refrigerant tubing

Connect tubing to fittings on outdoor unit vapor- and liquid-service valves. (See Fig. 2.)

**⚠ CAUTION: To avoid valve damage while brazing, service valves must be wrapped with a heat-sinking material such as a wet cloth.**

### C. Sweat connection

Use refrigerant grade tubing. Service valves are closed from factory and ready for brazing. After wrapping the service valve with a wet cloth, the tubing set can be brazed to the service valve using either silver bearing or non-silver bearing brazing material. Consult local code requirements. Refrigerant tubing and indoor coil are now ready for leak testing. This check should include all field and factory joints.

## PROCEDURE 5—MAKE ELECTRICAL CONNECTIONS

**⚠ WARNING: To avoid personal injury or death, do not supply power to unit with compressor terminal box cover removed.**

Be sure field wiring complies with local and national fire, safety and electrical codes, and voltage to system is within limits shown on unit rating plate. Contact local power company for correction of improper voltage. See unit rating plate for recommended circuit protection device.

**NOTE:** Operation of unit on improper line voltage constitutes abuse and could affect unit reliability. See unit rating plate. Do not install unit in system where voltage or phase imbalance may fluctuate above or below permissible limits.

**NOTE:** Use copper wire only between disconnect switch and unit.

**NOTE:** Install branch circuit disconnect per NEC of adequate size to handle unit starting current. Locate disconnect within sight from and readily accessible from unit, per Section 440-14 of NEC.

### A. Route Ground and Power Wires

Remove access panel to gain access to unit wiring. Extend wires from disconnect through power wiring hole provided and into unit control box. (See Fig. 2.)

**⚠ WARNING: According to NEC, ANSI/NFPA 70, and local codes, the cabinet must have an uninterrupted or unbroken ground, to minimize personal injury if an electrical fault should occur. The ground may consist of electrical wire or metal conduit when installed in accordance with existing electrical codes. Failure to follow this warning could result in an electric shock, fire, or death.**

### B. Connect Ground and Power Wires

Connect ground wire to ground connection in control box for safety. Connect power wiring to contactor as shown in Fig. 3.

### C. Connect Control Wiring

Route 24-v control wires through control wiring grommet and connect leads to control wiring. (See Fig. 4.)

Use No. 18 AWG color-coded, insulated (35° C minimum) wires. If thermostat is located more than 100 ft from unit, as measured along the control voltage wires, use No. 16 AWG color-coded wires to avoid excessive voltage drop.

Use furnace or fan-coil transformer as 24-v (40 va minimum) supply for system or use accessory transformer. When installed with liquid line solenoid valve, a 60-v transformer is required.

#### PROCEDURE 6—COMPRESSOR CRANKCASE HEATER

A crankcase heater is required if the refrigerant tubing is longer than 50 ft (15.24m).

**NOTE:** The Seasonal Energy Efficiency Ratio (SEER) is obtained with the crankcase heater de-energized. To de-energize the crankcase heater, disconnect the black crankcase heater wires at the contactor. After disconnecting, make sure wires are isolated from all other electrical connections and components to prevent electrical shorting.

#### PROCEDURE 7—INSTALL ELECTRICAL ACCESSORIES

Refer to the individual instructions packaged with the kits or accessories when installing.

#### PROCEDURE 8—START-UP

1. When equipped with a crankcase heater, energize heater a minimum of 24 hours before starting unit. To energize heater only, set thermostat to OFF position and close electrical disconnect to outdoor unit.
2. Fully OPEN liquid and vapor tube service valves.
3. Unit is shipped with valve stem(s) front seated, and caps installed. Replace stem caps after system is opened to refrigerant flow. Replace caps finger-tight and tighten additional 1/6- turn with wrench.
4. Close electrical disconnects to energize system.
5. Set room thermostat at desired temperature. Be sure set point is below indoor ambient temperature.
6. Set room thermostat at COOL and fan switch at FAN or AUTO, as desired. Operate unit for 15 minutes. Check system refrigerant charge. See Checking Charge below.

#### PROCEDURE 9—CHECKING CHARGE

Factory charge is shown on unit rating label. (See Fig. 2.) Charge procedure is shown on information label.

---

**⚠ CAUTION: Service valve gage ports are equipped with Schrader valves. To prevent personal injury, wear safety glasses and gloves when handling refrigerant.**

---

---

**⚠ CAUTION: Compressor damage may occur if system is overcharged.**

---

---

**⚠ CAUTION: Do not vent refrigerant to atmosphere. Recover during system repair or final unit disposal.**

---

### CARE AND MAINTENANCE

For continued high performance, and to minimize possible equipment failure, it is essential that periodic maintenance be performed on this equipment.

#### PROCEDURE 1—BEFORE YOU REQUEST A SERVICE CALL

Check the indoor and outdoor disconnect switches. Verify that circuit breakers are ON and that fuses have not blown.

Check for sufficient airflow. Check the air filter(s) for any accumulations of dirt. Check for blocked return-air or supply-air grilles. Be sure grilles are open and unobstructed.

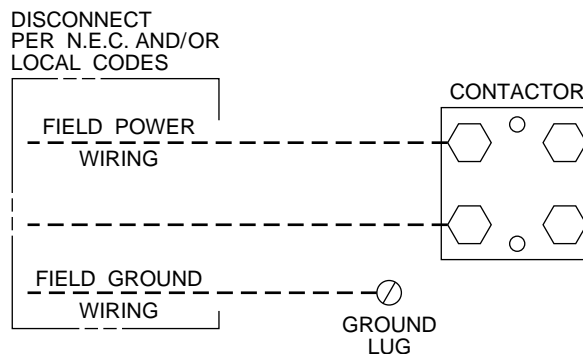

Fig. 3—Line Power Connections (Single Phase)

Check setting of your indoor thermostat. If you desire cooling, see that the temperature control selector is set below room temperature and the SYSTEM switch is on the COOL or AUTO position.

If your comfort system still fails to operate, contact your servicing dealer for troubleshooting and repairs. Specify your apparent problem, and state the model and serial numbers of your equipment. (You should record them on your warranty.) With this information your dealer may be able to offer helpful suggestions over the telephone or save valuable time through knowledgeable preparation for the service call.

#### **PROCEDURE 2—REGULAR DEALER MAINTENANCE**

In addition to the routine maintenance you perform, your home comfort system should be inspected regularly by a properly trained service technician. The inspection (preferably twice each year, but at least once every year) should include the following:

Routine inspection of air filter(s). Replacement or cleaning as required.

Inspection and cleaning of the blower wheel, housing, and motor as required.

Inspection of the indoor coil drain pan, plus the primary and secondary drain lines. If supplied, the auxiliary drain pan and line should be inspected at this time. Service should include cleaning if required.

A check of all electrical wiring and connections.

A check for secure physical connections of individual components within units.

Your servicing dealer may offer an economical service contract that covers seasonal inspections. Ask for further details.

#### **FOR THE RECORD**

Record the model and serial numbers of your new equipment in the spaces provided on your warranty. This information is necessary should you ever require information or service.

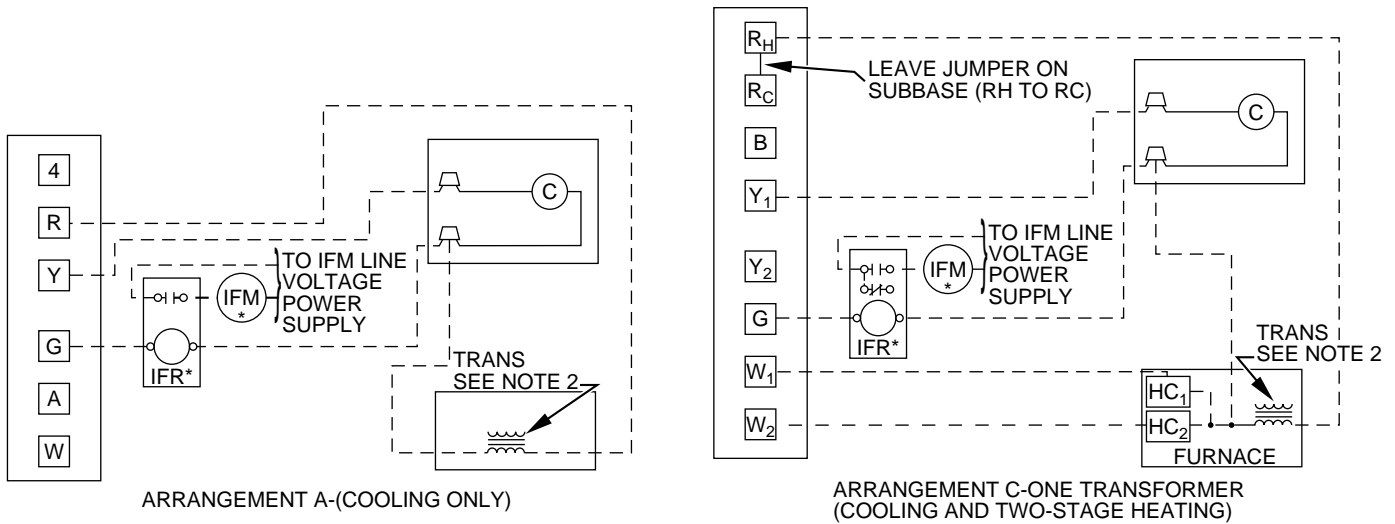

A91132

A91134

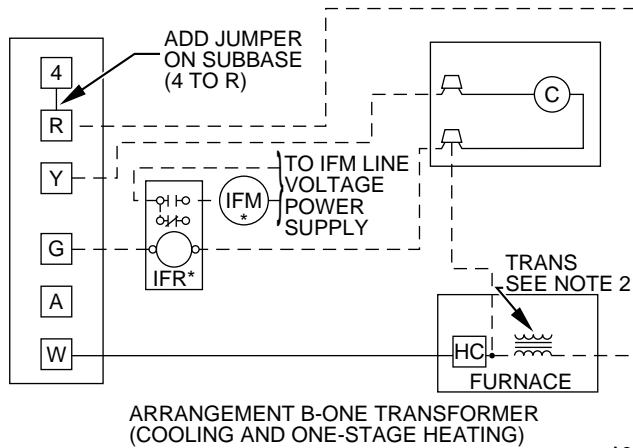

A91133

\*IFR AND IFM ARE LOCATED IN FURNACE ON HEATING-COOLING APPLICATIONS. IF ACCESSORY IFR IS REQUIRED FOR COOLING-ONLY APPLICATIONS, LOCATE (IFR) IN FAN COIL.

C	-CONTACTOR		FIELD SPLICE
HC	-HEATING CONTROL	----	FIELD WIRING
IFM	-INDOOR FAN MOTOR	—	FACTORY WIRING
IFR	-INDOOR FAN RELAY		
TRANS	-TRANSFORMER		

- NOTES:** 1. Refer to unit wiring label for wire colors: C to G and C to Y connections.  
 2. N.E.C. class 2, 24V circuit, min 40VA required; 60VA required for units installed with liquid line solenoid valve.

A91135

**Fig. 4—Typical 24-v Circuit Connections**