

INSTALLATION MANUAL

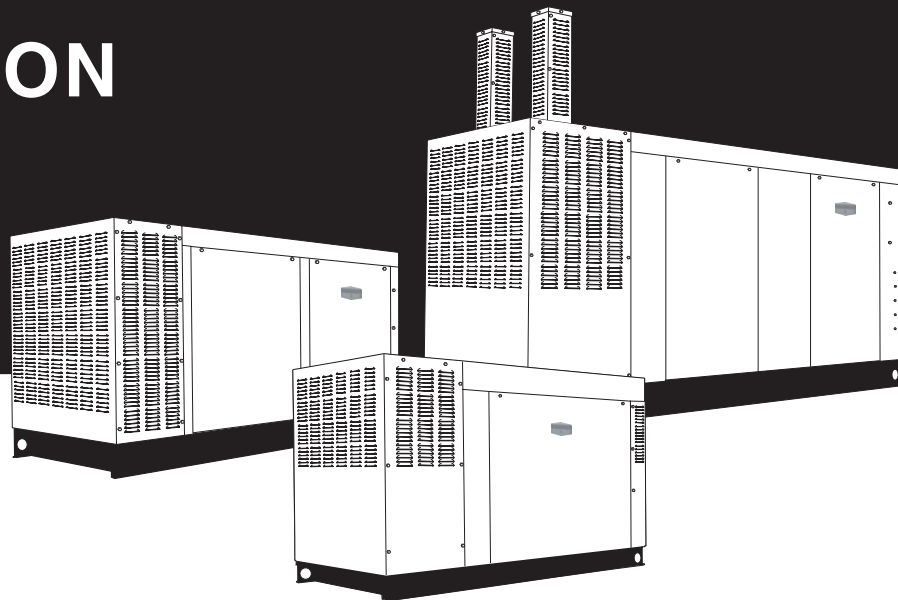

A new standard of reliability



Not intended for use in critical life support applications!

OUTDOOR INSTALLATION ONLY!



This manual should remain with the unit.

INTRODUCTION

Thank you for purchasing this model of the standby generator set.

Every effort was expended to make sure that the information and instructions in this manual are both accurate and current at the time the manual was written. However, the manufacturer reserves the right to change, alter or otherwise improve this product(s) at any time without prior notice.

◆ **READ THIS MANUAL THOROUGHLY**

If any portion of this manual is not understood, contact the nearest Dealer for starting, operating and servicing procedures.

Throughout this publication, and on tags and decals affixed to the generator, DANGER, WARNING, CAUTION and NOTE blocks are used to alert personnel to special instructions about a particular service or operation that may be hazardous if performed incorrectly or carelessly. Observe them carefully. Their definitions are as follows:



After this heading, read instructions that, if not strictly complied with, will result in serious personal injury, including death and/or property damage.



After this heading, read instructions that, if not strictly complied with, may result in serious personal injury and/or property damage.



After this heading, read instructions that, if not strictly complied with, could result in damage to equipment and/or property.

NOTE:

After this heading, read explanatory statements that require special emphasis.

These safety warnings cannot eliminate the hazards that they indicate. Common sense and strict compliance with the special instructions while performing the service are essential to preventing accidents.

Four commonly used safety symbols accompany the DANGER, WARNING and CAUTION blocks. The type of information each indicates is as follows:

 **This symbol points out important safety information that, if not followed, could endanger personal safety and/or property of others.**

 **This symbol points out potential explosion hazard.**

 **This symbol points out potential fire hazard.**

 **This symbol points out potential electrical shock hazard.**



◆ **HOW TO OBTAIN SERVICE**



When the generator requires servicing or repairs, contact a Dealer for assistance. Service technicians are factory-trained and are capable of handling all service needs.

When contacting a Dealer about parts and service, always supply the complete model number of the unit as given on the front cover of the Owner's Manual.

INTRODUCTION	IFC	Section 2 — INSTALLATION.....	11
SAFETY RULES	2	2.1 Transfer Switch.....	11
Section 1 — GENERAL INFORMATION.....	4	2.2 Unpacking.....	11
1.1 Generator Installation	4	2.3 Mounting.....	12
1.2 Before Installation	4	Section 3 — OPERATION.....	12
1.3 Generator Location	5	3.1 Basic Standby Electric System.....	12
1.4 Generator Mounting and Support	5	3.2 Standby Circuit Isolation Method.....	12
1.5 Unpacking.....	6	3.3 Total Circuit Isolation Method.....	12
1.6 Lifting the Generator	6	3.4 Connection Diagrams.....	12
1.7 Fuel Systems	6	3.5 Wire Recommendations/Sizing	14
1.8 Electrical Connections.....	8	Section 4 — NOTES.....	16
1.9 Battery Installation.....	11		



 **SAVE THESE INSTRUCTIONS** – The manufacturer suggests that these rules for safe operation be copied and posted in potential hazard areas. Safety should be stressed to all operators, potential operators, and service and repair technicians for this equipment. 

 **SAVE THESE INSTRUCTIONS** – This manual contains important instructions that should be followed during installation of the generator and batteries. 

 **WARNING:** 
The engine exhaust from this product contains chemicals known to the state of California to cause cancer, birth defects or other reproductive harm.

 **WARNING:** 
This product contains or emits chemicals known to the state of California to cause cancer, birth defects or other reproductive harm.

Study these SAFETY RULES carefully before installing, operating or servicing this equipment. Become familiar with this *Owner's Manual* and with the unit. The generator can operate safely, efficiently and reliably only if it is properly installed, operated and maintained. Many accidents are caused by failing to follow simple and fundamental rules or precautions.

The manufacturer cannot anticipate every possible circumstance that might involve a hazard. The warnings in this manual, and on tags and decals affixed to the unit are, therefore, not all inclusive. If using a procedure, work method or operating technique that the manufacturer does not specifically recommend, ensure that it is safe for others. Also make sure the procedure, work method or operating technique utilized does not render the generator unsafe.

 **DANGER** 

 Despite the safe design of this generator, operating this equipment imprudently, neglecting its maintenance or being careless can cause possible injury or death. Permit only responsible and capable persons to install, operate or maintain this equipment.

 Potentially lethal voltages are generated by these machines. Ensure all steps are taken to render the machine safe before attempting to work on the generator.

 Parts of the generator are rotating and/or hot during operation. Exercise care near running generators.

 **GENERAL HAZARDS** 

- For safety reasons, the manufacturer recommends that this equipment be installed, serviced and repaired by an Dealer or other competent, qualified electrician or installation technician who is familiar with applicable codes, standards and regulations. The operator also must comply with all such codes, standards and regulations.
- Installation, operation, servicing and repair of this (and related) equipment must always comply with applicable codes, standards, laws and regulations. Adhere strictly to local, state and national electrical and building codes. Comply with regulations the Occupational Safety and Health Administration (OSHA) has established. Also, ensure that the generator is installed, operated and serviced in accordance with the manufacturer's instructions and recommendations. Following installation, do nothing that might render the unit unsafe or in noncompliance with the aforementioned codes, standards, laws and regulations.
- The engine exhaust fumes contain carbon monoxide gas, which can be DEADLY. This dangerous gas, if breathed in sufficient concentrations, can cause unconsciousness or even death. For that reason, adequate ventilation must be provided. Exhaust gases must be piped safely away from any building or enclosure that houses the generator to an area where people, animals, etc., will not be harmed. This exhaust system must be installed properly, in strict compliance with applicable codes and standards.
- Keep hands, feet, clothing, etc., away from drive belts, fans, and other moving or hot parts. Never remove any drive belt or fan guard while the unit is operating.
- Adequate, unobstructed flow of cooling and ventilating air is critical to prevent buildup of explosive gases and to ensure correct generator operation. Do not alter the installation or permit even partial blockage of ventilation provisions, as this can seriously affect safe operation of the generator.
- Keep the area around the generator clean and uncluttered. Remove any materials that could become hazardous.
- When working on this equipment, remain alert at all times. Never work on the equipment when physically or mentally fatigued.
- Inspect the generator regularly, and promptly repair or replace all worn, damaged or defective parts using only factory-approved parts.



- Before performing any maintenance on the generator, disconnect its battery cables to prevent accidental start-up. Disconnect the cable from the battery post indicated by a NEGATIVE, NEG or (-) first. Reconnect that cable last.
- Never use the generator or any of its parts as a step. Stepping on the unit can stress and break parts, and may result in dangerous operating conditions from leaking exhaust gases, fuel leakage, oil leakage, etc.

 **ELECTRICAL HAZARDS** 

- All generators covered by this manual produce dangerous electrical voltages and can cause fatal electrical shock. Utility power delivers extremely high and dangerous voltages to the transfer switch as well as the standby generator. Avoid contact with bare wires, terminals, connections, etc., on the generator as well as the transfer switch, if applicable. Ensure all appropriate covers, guards and barriers are in place before operating the generator. If work must be done around an operating unit, stand on an insulated, dry surface to reduce shock hazard.
- Do not handle any kind of electrical device while standing in water, while barefoot, or while hands or feet are wet. **DANGEROUS ELECTRICAL SHOCK MAY RESULT.**
- If people must stand on metal or concrete while installing, operating, servicing, adjusting or repairing this equipment, place insulative mats over a dry wooden platform. Work on the equipment only while standing on such insulative mats.
- The National Electrical Code (NEC), Article 250 requires the frame and external electrically conductive parts of the generator to be connected to an approved earth ground and/or grounding rods. This grounding will help prevent dangerous electrical shock that might be caused by a ground fault condition in the generator set or by static electricity. Never disconnect the ground wire.
- Wire gauge sizes of electrical wiring, cables and cord sets must be adequate to handle the maximum electrical current (ampacity) to which they will be subjected.
- Before installing or servicing this (and related) equipment, make sure that all power voltage supplies are positively turned off at their source. Failure to do so will result in hazardous and possibly fatal electrical shock.
- Connecting this unit to an electrical system normally supplied by an electric utility shall be by means of a transfer switch so as to isolate the generator electric system from the electric utility distribution system when the generator is operating. Failure to isolate the two electric system power sources from each other by such means will result

in damage to the generator and may also result in injury or death to utility power workers due to backfeed of electrical energy.

- Generators installed with an automatic transfer switch will crank and start automatically when normal (utility) source voltage is removed or is below an acceptable preset level. To prevent such automatic start-up and possible injury to personnel, disable the generator's automatic start circuit (battery cables, etc.) before working on or around the unit. Then, place a "Do Not Operate" tag on the generator control panel and on the transfer switch.
- In case of accident caused by electric shock, immediately shut down the source of electrical power. If this is not possible, attempt to free the victim from the live conductor. **AVOID DIRECT CONTACT WITH THE VICTIM.** Use a nonconducting implement, such as a dry rope or board, to free the victim from the live conductor. If the victim is unconscious, apply first aid and get immediate medical help.
- Never wear jewelry when working on this equipment. Jewelry can conduct electricity resulting in electric shock, or may get caught in moving components causing injury.

 **FIRE HAZARDS** 

- Keep a fire extinguisher near the generator at all times. Do NOT use any carbon tetra-chloride type extinguisher. Its fumes are toxic, and the liquid can deteriorate wiring insulation. Keep the extinguisher properly charged and be familiar with its use. If there are any questions pertaining to fire extinguishers, consult the local fire department.

 **EXPLOSION HAZARDS** 

- Do not smoke around the generator. Wipe up any fuel or oil spills immediately. Ensure that no combustible materials are left in the generator compartment, or on or near the generator, as FIRE or EXPLOSION may result. Keep the area surrounding the generator clean and free from debris.
- This generator may operate using one of several types of fuels. All fuel types are potentially FLAMMABLE and/or EXPLOSIVE and should be handled with care. Comply with all laws regulating the storage and handling of fuels. Inspect the unit's fuel system frequently and correct any leaks immediately. Fuel supply lines must be properly installed, purged and leak tested according to applicable fuel-gas codes before placing this equipment into service.
- Gaseous fluids such as natural gas and liquid propane (LP) gas are extremely EXPLOSIVE. Natural gas is lighter than air, and LP gas is heavier than air; install leak detectors accordingly.

1.1 GENERATOR INSTALLATION

This equipment is a liquid-cooled, engine-driven generator set. The generator is designed to supply electrical power that operates critical electrical loads during utility power failure. The unit has been factory-installed in a weather resistant, all metal enclosure and is intended for outdoor installation only.

—▲ WARNING ▲—

▲ If this generator is used to power electrical load circuits normally powered by a utility power source, it is required by code to install a transfer switch. The transfer switch must effectively isolate the electric system from the utility distribution system when the generator is operating (NEC 701). Failure to isolate an electrical system by such means results in damage to the generator and may also result in injury or even death to utility power workers due to backfeed of electrical energy.

1.2 BEFORE INSTALLATION

Before installing this equipment, check the ratings of both the generator and the transfer switch. Read “Emergency Isolation Method” and “Total Circuit Isolation Method”.

The generator’s rated wattage/ampere capacity must be adequate to handle all electrical loads that the unit will power. The critical (essential) loads may need to be grouped together and wired into a separate “emergency” distribution panel.

—▲ DANGER ▲—

▲ Connecting this generator to an electrical system normally supplied by an electric utility shall be by means of a transfer switch, so as to isolate the electric system from the utility distribution system when the generator is operating. Failure to isolate the electric system by these means will result in damage to the generator and may also result in injury or death to utility workers due to backfeed of electrical energy.

▲ If an open bottom is used, the engine-generator is to be installed over non-combustible materials and should be located such that combustible materials are not capable of accumulating under the generator set.

Only qualified, competent installation contractors or electricians thoroughly familiar with applicable codes, standards and regulations should install this standby electric power system. The installation must comply strictly with all codes, standards and regulations pertaining to the installation.

—▲ CAUTION ▲—

▲ After the system has been installed, do nothing that might render the installation in noncompliance with such codes, standards and regulations.

◆ 1.2.1 NFPA STANDARDS

The following published standards booklets pertaining to standby electric systems are available from the National Fire Protection Association (NFPA), Batterymarch Park, Quincy, MA 02269:

- NFPA No. 37, STATIONARY COMBUSTION ENGINES AND GAS TURBINES
- NFPA No. 54, NATIONAL FUEL GAS CODE
- NFPA No. 58, LIQUEFIED PETROLEUM GAS CODE
- NFPA 70, NATIONAL ELECTRIC CODE (NEC)
- NFPA 99, STANDARD FOR HEALTH CARE FACILITIES
- NFPA 101, LIFE SAFETY CODE
- NFPA 110, STANDARD FOR EMERGENCY AND STANDBY POWER SYSTEMS
- NFPA 220, STANDARD TYPES OF BUILDING CONSTRUCTION

NOTE:

It is essential to use the latest version of any standard to ensure that the generator and its accessories comply with all the applicable standards and local codes.

◆ 1.2.2 OTHER PUBLISHED STANDARDS

In addition to NFPA standards, the following information pertaining to the installation and use of standby electric systems is available:

- Article X, NATIONAL BUILDING CODE, available from the American Insurance Association, 85 John Street, New York, N.Y. 10038.
- AGRICULTURAL WIRING HANDBOOK, obtainable from the Food and Energy Council, 909 University Avenue, Columbia, MO, 65201.
- ASAE EP-364.2, INSTALLATION AND MAINTENANCE OF FARM STANDBY ELECTRIC POWER, available from the American Society of Agricultural Engineers, 2950 Niles Road, St. Joseph, MI 49085.
- A52.1, AMERICAN NATIONAL STANDARD FOR CHIMNEYS, FIREPLACES AND VENTING SYSTEMS, available from the American National Standard Institute, 1430 Broadway, New York, N.Y. 10018.

NOTE:

It is essential to use the latest version of any standard to ensure that the generator and its accessories comply with all the applicable standards and local codes.

The installer must comply with all applicable state and local codes.

1.3 GENERATOR LOCATION

Install the generator set, in its protective enclosure outdoors, where adequate cooling and ventilating air always is available. Consider these factors:

- Install the unit where air inlet and outlet openings will not become obstructed by leaves, grass, snow, etc. If prevailing winds will cause blowing or drifting, consider using a windbreak to protect the unit.
- Install the generator on high ground where water levels will not rise and endanger it.
- This genset must be installed on a level surface. The base frame must be level within 1/2 inch all around.
- Allow sufficient room on all sides of the generator for maintenance and servicing. This unit must be installed in accordance with current applicable NFPA 37 and NFPA 70 standards, as well as any other federal, state and local codes for minimum distances from other structures.
- Where strong prevailing winds blow from one direction, face the generator air inlet openings into the prevailing winds.
- Install the generator as close as possible to the transfer switch. This reduces the length of wiring and conduit.
- Install the generator as close as possible to the fuel supply, to reduce the length of piping. HOWEVER, REMEMBER THAT LAWS OR CODES MAY REGULATE THE DISTANCE.

1.4 GENERATOR MOUNTING AND SUPPORT

A CONCRETE BASE:

When designing a concrete base slab, all federal, state and local codes should be followed. Special attention should be given to the concrete base slab which should exceed the length and width of the generator by a minimum of six (6) inches (0.152 meters) on all sides.

Retain the generator compartment to the concrete slab with masonry bolts.

◆ 1.4.1 COMBUSTIBLE FLOOR AND ROOF PROTECTION

If the generator must be installed on any combustible floor or roof, comply with the following rules:

- Place a layer of non-combustible insulation, followed by a layer of sheet metal beneath the unit's mounting base rails (Figure 1.1).
- Both the layer of insulation and the sheet metal must extend beyond the generator base to a distance of at least 12 inches (30.5 cm) on all sides.

Figure 1.1 — Combustible Floor and Roof Protection

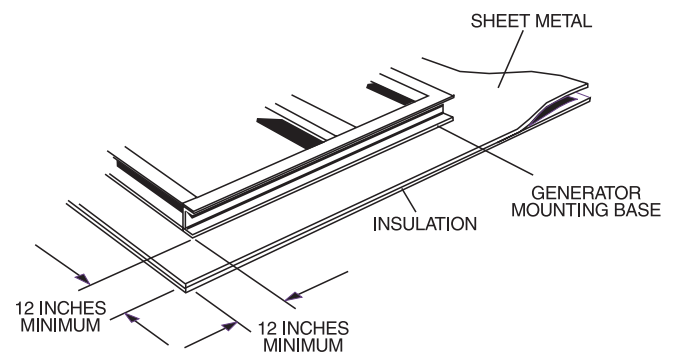

For rooftop or building structure mounting, it is recommended that spring isolators be installed between the engine frame and the mounting system. A minimum of six (6) isolators are required and must be located at the front and rear cross members and the center of the frame.

Since the entire bottom of the genset is now exposed, it should be covered with a metal plate to keep out small animals and protect the integrity of the internal parts of the genset. Genset movement is more intense with spring isolation, so flexible connections for the fuel and the electrical conduits are also required.

NOTE:

Consult the local building codes which may vary.

1.5 UNPACKING

◆ 1.5.1 UNPACKING PRECAUTIONS

Handle shipping cartons and crates with care. Use care to avoid damage from dropping, bumping, collision, etc. Store and unpack cartons with the proper side up, as noted on the shipping carton.

◆ 1.5.2 INSPECTION

After unpacking, carefully inspect the generator for any damage that may have occurred during shipment. If loss or damage is noted at the time of delivery, have the person(s) making delivery note all damage on the freight bill or affix their signature under the consignor's memo of loss or damage.

1.6 LIFTING THE GENERATOR



▲ When lifting or hoisting equipment is used, be careful not to touch overhead power lines. The generators weight of more than 900 pounds requires proper tools, equipment, and qualified personnel to be used in all phases of handling and unpacking.

1.7 FUEL SYSTEMS

◆ 1.7.1 INTRODUCTION TO GASEOUS FUEL SYSTEMS



▲ Gaseous fuels, such as LP and natural gas, are highly volatile and their vapors are explosive. LP gas is heavier than air and will settle in low areas. Natural gas is lighter than air and will settle in high areas. Even the slightest spark can ignite these fuels and cause an explosion. For safety, all codes, standards and regulations pertaining to the installation and use of gaseous fuels must be strictly complied with.

Local fuel gas codes may vary widely. For that reason, it is recommended that a local gas distributor or installer be consulted when installing a gaseous fuel supply system.

In the absence of local fuel gas codes and regulations, booklets published by the National Fire Protection Association (NFPA) may be used as sources of information.

◆ 1.7.2 PROPERTIES OF GASEOUS FUELS

Natural Gas

Natural gas is lighter than air. It is found in the gaseous state at normal ambient temperatures and pressures. It is highly explosive and can be ignited at the slightest spark. For that reason, fuel lines must be free of leaks and adequate ventilation is absolutely essential.

Local fuel/gas codes usually dictate the maximum pressure at which natural gas can enter a structure. In order to reduce the gas pressure to that required by law, a PRIMARY REGULATOR is required.

LP Gas

Liquefied petroleum (LP) gas is heavier than air. The gas vapors are explosive and, like natural gas, can be ignited by the slightest spark.

LP tank pressure is dependent on the ambient temperature and can be as high as 200 psi. A primary regulator is required at the tank to reduce the pressure to the required five to 14 inches of water column for units less than 70kW, or 11 to 14 inches of water column for units 70kW and larger.

◆ 1.7.3 THE NATURAL GAS SYSTEM

A typical natural gas system is shown in Figure 1.2, below. The maximum pressure at which the gas can enter a building is established by code and may vary from area to area. A primary regulator is required to reduce gas supply pressures to the required safe level before the gas enters a structure.

The primary regulator may or may not be provided by the gas supplier. The gas distribution company will usually provide piping from the main distribution line to the generator site. It is the responsibility of the gas supplier to ensure that sufficient gas pressure is available to operate the primary regulator.

From the primary regulator, gas flows to the generator connection. A flexible length of gas line is required between rigid piping and the gas connection at the generator. The generator fuel system consists of an electrical fuel shutoff valve/regulator assembly and a gas actuator.

The secondary regulator reduces gas pressure to about five inches of water column before the gas is delivered to the actuator.

NOTE:

Gas pressure from the primary regulator (supplied by the installing contractor) to the generator's fuel shutoff valve should not exceed 14 inches of water column. Units can operate with the pressure as low as five inches of water column.

Figure 1.2 — Typical Natural Gas System

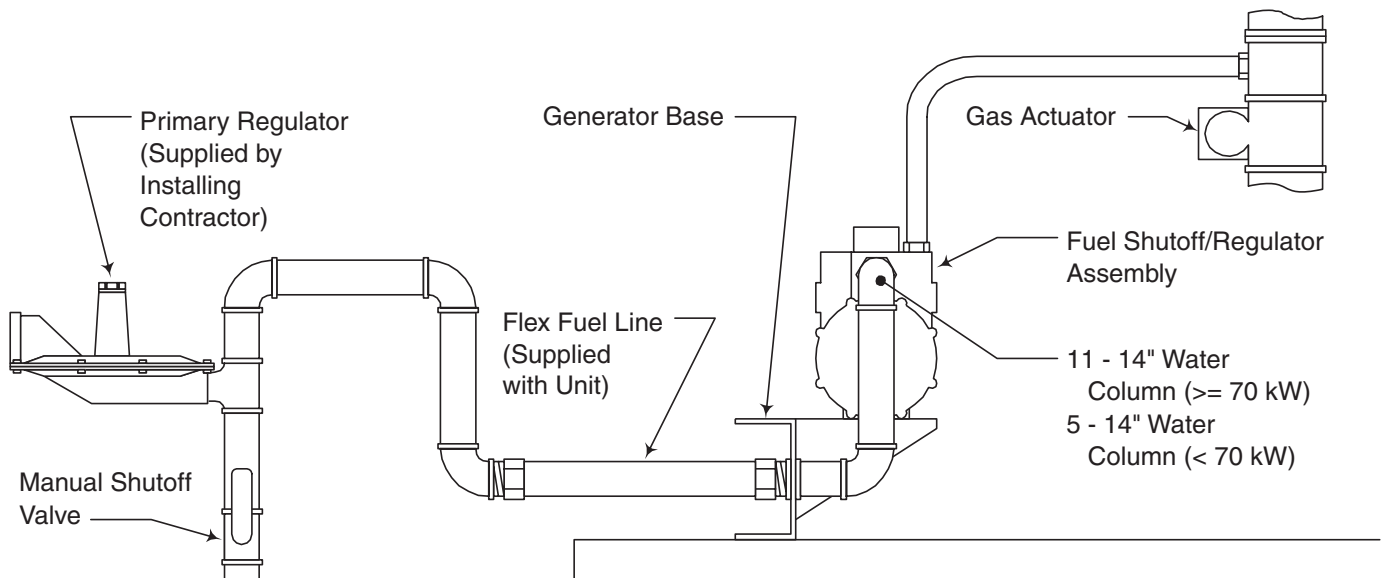

Follow the local codes on selecting the required AGA approved, and UL listed, for NG application flexible portion of the fuel line (supplied by the installing contractor).

◆ **1.7.4 LP GAS VAPOR WITHDRAWAL SYSTEM**

This type of system utilizes the vapors formed above the liquid fuel in the supply tank (see Figure 1.3). Approximately 10 to 20 percent of the tank capacity is needed for fuel expansion from the liquid to the vapor state. Gas pressure requirements for an LP vapor system at the frame of the generator are the

same as those listed for natural gas in "The Natural Gas System". See Table 1 for information regarding the vapor capacity of LP tanks. The installer should be aware of the following:

- When ambient temperatures are low and engine fuel consumption is high, the vapor withdrawal system may not function efficiently.
- Ambient temperatures around the supply tank must be high enough to sustain adequate vaporization or the system will not deliver the needed fuel volume.

Figure 1.3 — Typical LP Gas Vapor Withdrawal System

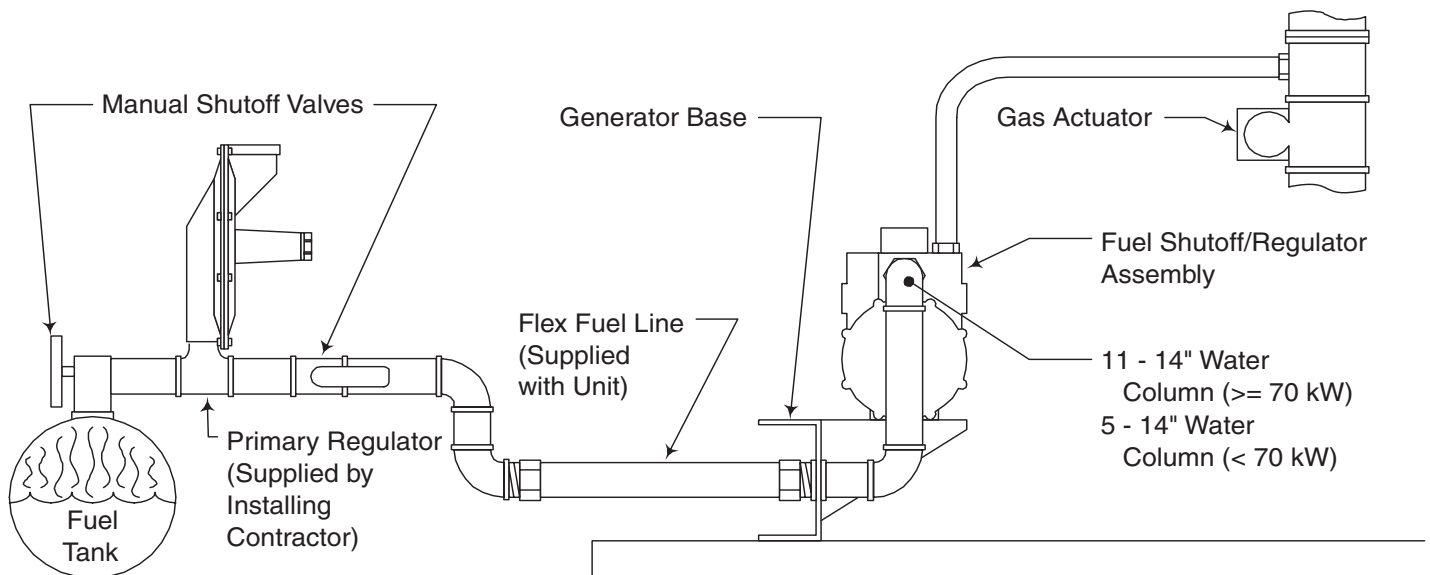

- In addition to the cooling effects of ambient air, the vaporization process itself provides an additional cooling effect.

◆ 1.7.5 GASEOUS FUEL SYSTEM PIPING

NOTE:

The information below is to assist in planning gaseous fuel installation. In NO WAY should this information be interpreted to conflict with applicable fuel gas codes. Contact the local jurisdiction if questions arise.

The following general rules apply to piping used in gaseous fuel systems:

- The piping should be of black iron, rigidly mounted and protected against vibration.
- Install the supplied length of flexible hose between the generator connection point and rigid piping.



⚠ The supplied flexible hose is not to be installed underground or in contact with ground. The flexible hose is for in-line installation only. Bends, kinks or off-center in-line installation of flexible hose is NOT allowed.

- Piping must be of the correct size to maintain the required supply pressures and volume flow under varying conditions (see Table 2).
- Installed piping must be properly purged and leak-tested, in accordance with applicable codes and standards.
- Use an approved pipe sealant or joint compound on all threaded fittings, to reduce the possibility of leakage.

NOTE:

In the absence of local purging and leak test standards, NFPA No. 54 may be used as a guide.

1.8 ELECTRICAL CONNECTIONS

◆ 1.8.1 GROUNDING THE GENERATOR

A GROUNDING LUG is provided on the generator mounting base for the purpose of grounding the frame and the external electrically conductive parts of this equipment to an approved earth ground and/or grounding rods where required by the National Electrical Code (Figure 1.4). Consult a qualified electrician for grounding requirements in the area. Grounding procedures must meet local regulations.



⚠ Do not connect the ground wire to any pipe that carries a flammable or explosive substance – FIRE or an EXPLOSION may result.

Proper grounding helps protect personnel against electrical shock in the event of a ground fault condition in the generator or in connected electrical devices. In addition, grounding helps dissipate static electricity that often builds up in ungrounded devices.

Figure 1.4 – Generator Grounding Lug (typical)

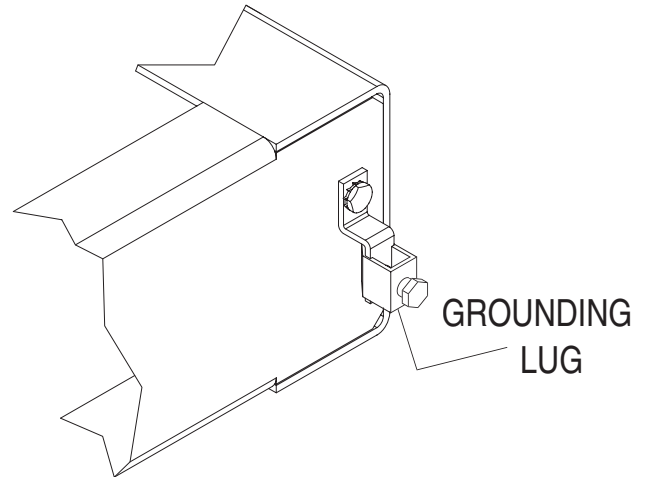

◆ 1.8.2 BATTERY CHARGER CONNECTION

The generator has been equipped with a 2 Amp battery charger installed in the control panel. Power leads for the charger have been run to the connection box (Figure 1.5). On units equipped with 2.5L engines, this connection is found in the control panel. **The terminals will need to be supplied from a 120VAC, 15 Amp circuit.**

Figure 1.5 — Battery Charger Connection

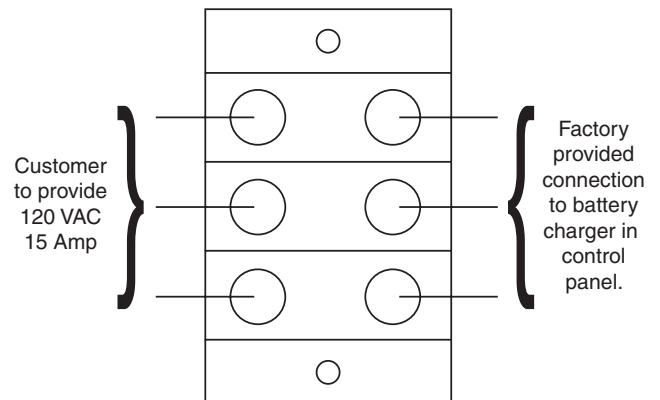

(See the wiring diagram in the Owner's Manual that is supplied with the unit.)

◆ **TABLE 1 – VAPOR CAPACITY OF PROPANE STORAGE TANKS**

To Use: Go to the First column and pick the required kW load and then pick the minimum ambient temperature (40°, 20° or 0° F) that the generator would be operating in. The third column (tank capacity) will give the required tank size to continually produce the given fuel flow.

Max kW Vapor	Minimum Temp	Operating Hours @ Max kW	Tank Capacity (Gallons)	Length Inches	Dia Inches	Overall Ht. Inches
30	40	24	120	57	24	33
20	20	35				
10	0	67				
35	40	26	150	68	24	33
25	20	36				
12	0	72				
60	40	26	250	94	30	39
40	20	38				
20	0	74				
80	40	26	325	119	30	39
50	20	40				
25	0	77				
100	40	31	500	119	37	46
60	20	51				
30	0	100				
150	40	35	850	165	41	50
100	20	53				
50	0	105				
170	40	36	1000	192	41	50
120	20	51				
60	0	103				

Propane storage tanks can provide either a liquid or a vapor supply to the generator. The above chart is for **vapor withdrawal only** and provides the kW output or amount of vapor that can be withdrawn at a given temperature while keeping the temperature of the liquid above the boiling point. If the withdrawal rate is too high, the LP temperature goes below the boiling point, the pressure drops to zero and no vapor can be withdrawn. A primary regulator is also required at the tank to reduce the line pressure to the generator to 5-14 inches of water column.

Propane Conversions: 36.38 ft³ = 90,500 btu = 1 gal • 11b = 21,500 btu = 8.56 ft³

Figure 1.6 — Propane Storage Tank

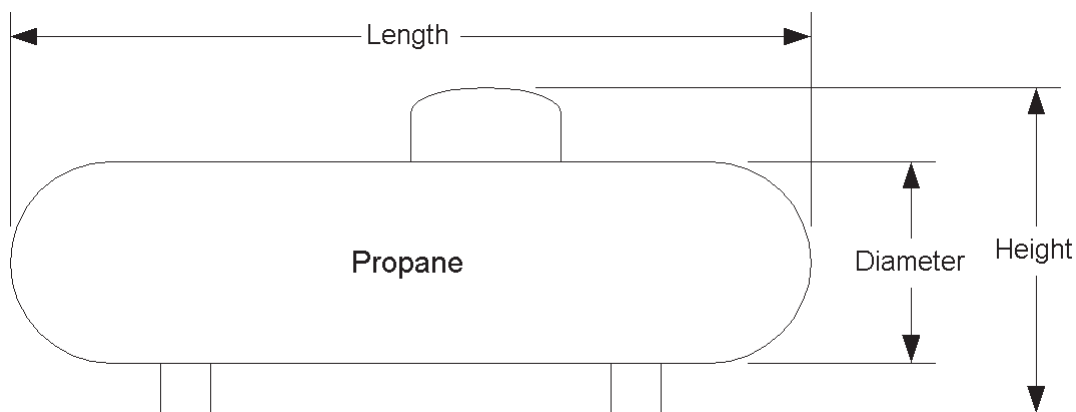

◆ TABLE 2 – GAS FLOW-PIPE SIZE CHART

This table is based on a specific gravity of 1.00 (specific gravity of air). For that reason, a correction is required when the fuel used has a different specific gravity. The fuel's specific gravity can be obtained from the fuel supplier. The table is also based on a pressure drop of 0.3, which allows for a nominal amount of restrictions from bends, fittings, etc. An example of how to calculate pipe size follows the table.

Example: It is determined that a generator set running at 100% of rated load on natural gas requires 545 cubic feet of gas per hour. The unit is located 75 feet from the supply tank and will use gas having a specific gravity of 0.65 (multiplier is 0.962). From the table below, it is apparent that a 1-1/2 inch pipe will deliver 524.29 cubic feet of gas per hour. The next larger pipe (2 inch) will deliver 1120 cubic feet per hour and, when the correction factor is applied, will actually deliver 1077.4 cubic feet per hour. The 2 inch pipe is required at the given distance of 75 feet. Pressure drop does not have to be considered unless an unusual number of fittings, bends or other restrictions are used. In such unusual cases, the fuel supplier will usually specify which multiplier is applicable.

Length of Pipe (In Feet)	Iron Pipe Size (IPS Inches)										
	1/2"	3/4"	1"	1-1/4"	1-1/2"	2"	2-1/2"	3"	4"	6"	8"
15	76	172	345	750	1220	2480	3850	6500	13880	38700	79000
30	52	120	241	535	850	1780	2750	4700	9700	27370	55850
45	43	99	199	435	700	1475	2300	3900	7900	23350	45600
60	38	86	173	380	610	1290	2000	3450	6800	19330	39500
75		77	155	345	545	1120	1750	3000	6000	17310	35300
90		70	141	310	490	1000	1560	2700	5500	15800	32250
105		65	131	285	450	920	1430	2450	5100	14620	29850
120			120	270	420	860	1340	2300	4800	13680	27920
150			109	242	380	780	1220	2090	4350	12240	25000
180			100	225	350	720	1120	1950	4000	11160	22800
210			92	205	320	660	1030	1780	3700	10330	21100
240				190	300	620	970	1680	3490	9600	19740
270				178	285	580	910	1580	3250	9000	18610
300				170	270	545	860	1490	3000	8500	17660
450				140	226	450	710	1230	2500	7000	14420
600				119	192	390	600	1030	2130	6000	12480

CORRECTION FACTORS

Specific Gravity	Multiplier	Specific Gravity	Multiplier	Pressure Drop	Multiplier
0.50	1.10	1.0	0.775	0.1	0.577
0.55 (Sewage Gas)	1.04	1.2	0.707	0.2	0.815
0.60	1.00	1.4	0.655	0.3	1.000
0.65 (Natural Gas)	0.962	1.5 (Propane)	0.633	0.5	1.29
0.70	0.926	1.7	0.594	1.0	1.83
0.80	0.867	1.9	0.565	2.0	2.58
0.90	0.817	2.1 (Butane)	0.535	5.0	4.08

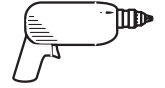

1.9 BATTERY INSTALLATION

—▲ DANGER ▲—

- ⚠ Standby generators installed with automatic transfer switches will crank and start automatically when NORMAL (UTILITY) source voltage is removed or is below an acceptable preset level. To prevent such automatic start-up and possible injury to personnel, do not connect battery cables until certain that normal source voltage at the transfer switch is correct and the system is ready to be placed into operation.
- ⚠ Storage batteries give off explosive hydrogen gas. This gas can form an explosive mixture around the battery for several hours after charging. The slightest spark can ignite the gas and cause an explosion. Such an explosion can shatter the battery and cause blindness or other injury. Any area that houses a storage battery must be properly ventilated. Do not allow smoking, open flame, sparks or any spark producing tools or equipment near the battery.
- ⚠ Battery electrolyte fluid is an extremely caustic sulfuric acid solution that can cause severe burns. Do not permit fluid to contact eyes, skin, clothing, painted surfaces, etc. Wear protective goggles, protective clothing and gloves when handling a battery. If fluid is spilled, flush the affected area immediately with clear water.

—▲ WARNING ▲—

- ⚠ Do not dispose of the battery in a fire. The battery is capable of exploding.
- ⚠ Do not open or mutilate the battery. Released electrolyte can be toxic and harmful to the skin and eyes.
- ⚠ The battery represents a risk of high short circuit current. When working on the battery, always remove watches, rings or other metal objects, and only use tools that have insulated handles.

◆ 1.9.1 VENTED BATTERIES

—▲ CAUTION ▲—

- ⚠ The electrolyte is a dilute sulfuric acid that is harmful to the skin and eyes. It is electrically conductive and corrosive. The following procedures are to be observed:
 - Wear full eye protection and protective clothing,
 - Where electrolyte contacts the skin, wash it off immediately with water,
 - Where electrolyte contacts the eyes, flush thoroughly and immediately with water and seek medical attention, and

- Spilled electrolyte is to be washed down with an acid-neutralizing agent. A common practice is to use a solution of one pound (500 grams) bicarbonate of soda to one gallon (4 liters) of water. The bicarbonate of soda solution is to be added until the evidence of reaction (foaming) has ceased. The resulting liquid is to be flushed with water and the area dried.
- ⚠ Lead acid batteries present a risk of fire because they generate hydrogen gas. The following procedure are to be followed:
 - DO NOT SMOKE when near batteries,
 - DO NOT cause flame or spark in battery area, and
 - Discharge static electricity from body before touching batteries by first touching a grounded metal surface.

Servicing of batteries is to be performed or supervised by personnel knowledgeable of batteries and the required precautions. Keep unauthorized personnel away from batteries.

For recommended batteries, see the “Specifications” section in the Owner’s Manual. All batteries must be at 100 percent state-of-charge before they are installed on the generator.

When using maintenance-free batteries, it is not necessary to check the specific gravity or electrolyte level. Have these procedures performed at the intervals specified in the “Maintenance” section in the Owner’s Manual. A negative ground system is used. Battery connections are shown on the wiring diagrams. Make sure all batteries are correctly connected and terminals are tight. Observe battery polarity when connecting batteries to the generator set.

NOTE:

Damage will result if the battery connections are made in reverse.

2.1 TRANSFER SWITCH

The generator system includes a matched automatic transfer switch which is intended to be used in conjunction with the generator. It is supplied in a NEMA 3R enclosure. The NEMA 3R enclosure is weather proof and can be used indoors or outdoors.

2.2 UNPACKING

Carefully unpack the transfer switch. Inspect closely for any damage that might have occurred during shipment. The purchaser must file with the carrier any claims for loss or damage incurred while in transit.

Check that all packing material is completely removed from the switch prior to installation.

Attach any lifting device to the transfer switch mounting holes or brackets only. DO NOT LIFT THE SWITCH AT ANY OTHER POINT.

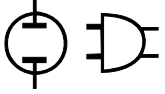

2.3 MOUNTING

Mounting dimensions for the transfer switch enclosure can be found in the transfer switch owner's manual. Enclosures are typically wall-mounted.



- ⚠ **Handle transfer switches carefully when installing. Do not drop the switch. Protect the switch against impact at all times, and against construction grit and metal chips. Never install a transfer switch that has been damaged.**

Install the transfer switch as close as possible to the electrical loads that are to be connected to it. Mount the switch vertically to a rigid supporting structure. To prevent switch distortion, level all mounting points. If necessary, use washers behind mounting holes to level the unit. Never install the switch where water or any corrosive substance might drip into the enclosure.

3.1 BASIC STANDBY ELECTRIC SYSTEM

Figure 3.1 shows a schematic diagram of a basic standby electric system. Both the UTILITY power supply and the STANDBY (GENERATOR) output are connected to an approved transfer switch. The transfer switch is required by electrical code and serves the following functions:

- Allows the LOAD circuits to be connected to only one power supply at a time.
- Prevents electrical backfeed between the generator and the UTILITY power circuits.

Figure 3.1 – Basic Standby Electric System

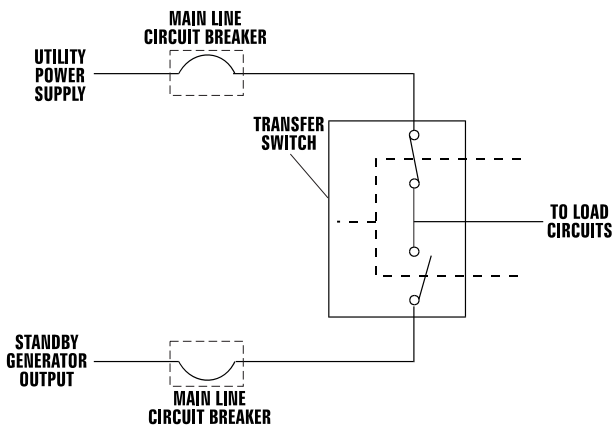

Notice that both the STANDBY and the UTILITY power supplies to the transfer switch are protected against overload by a main line circuit breaker.

3.2 STANDBY CIRCUIT ISOLATION METHOD

This prevents overloading the generator by keeping electrical loads below the wattage/amperage capacity of the generator. If the generator is powering only designated loads, within the wattage/amperage capacity, during utility power outages, consider using the emergency circuit isolation method.

Designated electrical loads are grouped together and wired into a separate “Standby Distribution Panel.” Load circuits powered by that panel are within the wattage/amperage capacity of the generator set. When this method is used, it is difficult to overload the generator. The transfer switch must meet the following requirements:

- It must have an ampere rating equal to the total amperage rating of the standby distribution panel circuit.
- Have it installed between the building's main distribution panel and the standby distribution panel.

3.3 TOTAL CIRCUIT ISOLATION METHOD

When a generator capable of powering all electrical loads in the circuit is to be installed, use the “Total Circuit Isolation Method.” It is possible for the generator to be overloaded when this isolation method is employed. The following apply to the transfer switch in this type of system.

- Ampere rating of the transfer switch must equal the ampere rating of the normal incoming utility service.
- The transfer switch is installed between the utility service entrance and the building distribution panel.

3.4. CONNECTION DIAGRAMS

All wiring in the standby electric power system must be in strict compliance with applicable codes, standards and regulations. Such wiring must be properly supported, routed, and connected. In addition, wiring must be properly sized to carry the maximum load current to which it will be subjected.

The connections between the generator and transfer switch will vary depending on the equipment ordered. In each case there are two types of interconnections, load wiring and control wiring.

NOTE:

Control wiring must always be run in a separate conduit from the load wiring.

⚠ DANGER ⚠

⚠ Make sure to turn OFF both the NORMAL (UTILITY) and STANDBY (EMERGENCY) power supplies before trying to connect power source and load lines to the transfer switch. Supply voltages are extremely high and dangerous. Contact with such high voltage power supply lines causes extremely hazardous, possibly lethal, electrical shock.

⚠ CAUTION ⚠

⚠ Be sure to maintain proper electrical clearances between live electrical parts and grounded metal. Allow at least one-half inch of clearance circuits up to 400 amps.

⚠ DANGER ⚠

⚠ Extremely high and potentially lethal supply voltages are present at the transfer switch when verifying phase rotation. This operation should only be performed by a trained electrician.

◆ 3.4.1 R-SERIES TO RTS

The R-series generator consists of an AUTO/OFF/MANUAL switch, a SET EXERCISE switch, and several fault indicator LEDs. See Figure 3.2 for an interconnection diagram. On units equipped with 2.5L engines, the control connections and main circuit breaker are found in the control panel. In this configuration the control wires consist of Utility 1 and Utility 2 (N1 and N2), and 23 and 194. See "Control Wiring" for control wire sizing recommendations.

⚠ DANGER ⚠

⚠ Make sure to turn OFF the NORMAL (UTILITY) power supply before trying to connect the Utility 1 and Utility 2 control wires. Supply voltages are extremely high and dangerous. Contact with such high voltage power supply lines causes extremely hazardous, possibly lethal, electrical shock.

Figure 3.2 — R-series to RTS

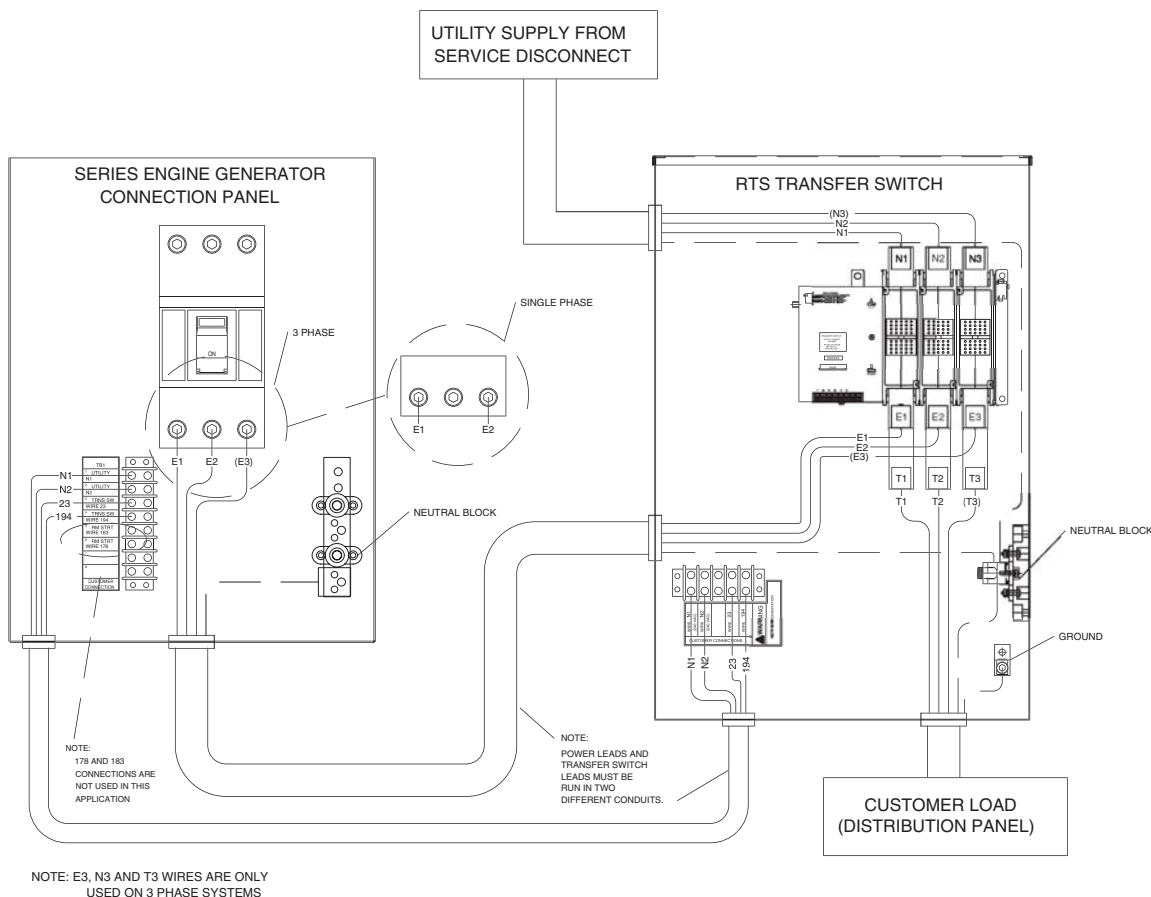

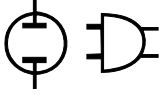

CAUTION

⚠ Terminals 178 and 183 in the generator AC connection box are not used in this application. Connection of any wires to these terminals may result in unwarrantable damage to the control board.

The load wires consist of wires run between the generator main circuit breaker and the transfer mechanism, and a neutral wire. See "Wire Recommendations/Sizing" for load wire sizing information.

3.5 WIRE RECOMMENDATIONS/ SIZING (SEE TABLE 3)

◆ 3.5.1 CONTROL WIRING

Control system interconnections on an R-series controlled generator consist of N1 and N2, and leads 23 and 194. Control system interconnection leads must be run in a conduit that is separate from the AC power leads. Recommended wire gauge size depends on the length of the wire:

Max. Cable Length	Recommended Wire Size
460 feet (140m)	No. 18 AWG.
461 to 730 feet (223m)	No. 16 AWG.
731 to 1,160 feet (354m)	No. 14 AWG.
1,161 to 1850 feet (565m)	No. 12 AWG.

◆ 3.5.2 LOAD WIRING

Power source and load line conductors must be properly supported, of approved insulative qualities, and of the correct wire gauge size.

When connecting power, source, and load lines remove surface oxides from stripped ends of conductors with a wire brush. Apply joint compound to stripped ends of conductors. Tighten terminals to the specified torque value, as given in the owner's manual for the transfer switch.

Recommended wire gauge size depends on the current rating of the generator main circuit breaker.

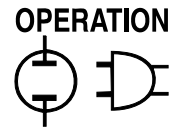

◆ **TABLE 3 – ALLOWABLE AMPACITIES OF INSULATED CONDUCTORS RATED 0-2000 VOLTS, 60° TO 90° C (140° TO 194° F). NOT MORE THAN THREE CONDUCTORS IN RACEWAY OR CABLE OR EARTH (DIRECTLY BURIED), BASED ON AMBIENT TEMPERATURE OF 30° C (86° F) (REFERENCE NEC TABLE 310-16)**

SIZE AWG kcmil	TEMPERATURE RATING OF CONDUCTOR						SIZE AWG
	60° C (140° F)	75° C (167° F)	90° C (194° F)	60° C (140° F)	75° C (167° F)	90° C (194° F)	
	TYPES TW¥, UF¥	TYPES FEPW¥ RH¥, RHW¥ THHW¥ THW¥ THWN¥ XHHW¥ USE¥, ZW¥	TYPES TA, TBS, SA SIS, FEP¥ FEPB¥ RHH¥, RHW2 THHN¥, THHW¥ THW2, THWN2 USE2, XHH XHHW¥ XHHW2, ZW2	TYPES TW¥ UF¥	TYPES RH¥, RHW¥ THHW¥ THW¥ THWN¥ XHHW¥ USE¥	TYPES TA, TBS SA, SIS, THHN¥ THHW¥ THW2, THWN2 RHH¥, RHW2 USE2 XHH, XHHW XHHW2, ZW2	
COPPER			ALUMINUM OR COPPER CLAD ALUMINUM				
18	—	—	14	—	—	—	—
16	—	—	18	—	—	—	—
14	20¥	20¥	25¥	—	—	—	—
12	25¥	25¥	30¥	20¥	20¥	25¥	12
10	30	35¥	40¥	25	30¥	35¥	10
8	40	50	55	30	40	45	8
6	55	65	75	40	50	60	6
4	70	85	95	55	65	75	4
3	85	100	110	65	75	85	3
2	95	115	130	75	90	100	2
1	110	160	150	85	100	115	1
1/0	125	150	170	100	120	135	1/0
2/0	145	175	195	115	135	150	2/0
3/0	165	200	225	130	155	175	3/0
4/0	195	230	260	150	180	205	4/0
250	215	255	290	170	205	230	250
300	24	285	320	190	230	255	300
350	260	310	350	210	250	280	350
400	280	335	380	225	270	305	400
500	320	380	430	260	310	350	500
600	355	42	475	285	340	385	600
700	385	460	520	310	375	420	700
750	400	475	535	320	385	435	750
800	410	490	555	330	395	450	800
900	435	520	585	355	425	480	900
1000	455	545	615	375	445	500	1000
1250	495	590	665	405	485	545	1250
1500	520	625	705	435	520	585	1500
1750	545	650	735	455	545	615	1750
2000	560	665	750	470	560	630	2000

¥ Unless otherwise specifically permitted in the NEC, the overcurrent protection for conductor types marked with an ¥ shall not exceed 15 amperes for No. 14, 20 amperes for No. 12, and 30 amperes for No. 10 copper; or 15 amperes for No. 12 and 25 amperes for No. 10 aluminum and copper-clad aluminum after any correction factors for ambient temperature and number of conductors have been applied.

