

INSTALLATION GUIDELINES

Air-cooled Generators



TABLE OF CONTENTS

Introduction.....	Inside Front Cover
General Hazards	IFC
Generator Installation	1
Before Installation.....	1
NFPA Standards.....	1
Other Published Standards.....	1
Grounding the Generator.....	2
Battery Installation	2
Vented Batteries	2
Before You Begin	2
Site Preparation and Generator Placement.....	2
Coverting to LP Vapor.....	3
Installing & Connecting Gas Lines	4
Battery Charger Installation.....	5
External Electrical Connections	6
Generator Connections - RTS Load Center	
Transfer Switch	6
Appendix A - RTS Pre-wired Load Center Transfer	
Switch Installation & Operational Testing	8
Battery Installation	9
Operational Testing	10
Appendix B - RTSN Nd RTSE Transfer Switch	
Installation & Operational Testing.....	12
Selected Circuit Coverage.....	12
Whole-house Circuit Coverage.....	13
Battery Charger Installation	13
Electrical Connections	13
Operational Testing	14
Appendix C - PowerMaster™ Load Controller	
Installation and Operationa Testing.....	16
Operational Testing	17
Checking the Priority Load Controller.....	20
Appendix D - PowerManager™ Load Shed Transfer	
Switch Installation and Operational Testing.....	21
Battery Charger Installation	22
Electrical Connections	22
Operational Testing	24
Verifying Load Shedding Operation	25
Appendix E - GenReady™ Load Center Installation	
and Operational Testing	28
Battery Charger Installation	28
Electrical Connections	29
Operational Testing	30
Appendix F - Setting the Automatic Exercise	
Function	32
Notes.....	34
Electrical Data.....	36

INTRODUCTION

This booklet and the accompanying video are designed to familiarize personnel with the installation process for air-cooled generators. This booklet does not replace or supersede any information contained in any of the other written documents shipped with the equipment. This booklet should only be use in conjunction with the Owner's Manual, Installation Guide and other technical documents shipped with the equipment.

Future product updates and/or modifications will be reflected in the written documentation included with Generac equipment. Always read all accompanying documentation carefully before attempting to install any generator, transfer switch or related equipment.

It is essential to comply with all regulations established by the Occupational Safety and Health Administration (OSHA) and strict adherence to all local, state and national codes is mandatory.

Study the SAFETY RULES in the Owner's Manual carefully before installing, operating or servicing any equipment. Use this guide ONLY in conjunction with the Owner's Manual and Installation Guide shipped with the generator. The generator can operate safely, efficiently and reliably only if it is properly installed, operated and maintained.

The manufacturer cannot anticipate every possible circumstance that might involve a hazard. The warnings in this manual, and on tags and decals affixed to the unit are, therefore, not all-inclusive.

Despite the safe design of this generator, operating this equipment imprudently, neglecting its maintenance or being careless can cause possible injury or death.

Permit only responsible and capable persons to install, operate or maintain this equipment.

Potentially lethal voltages are generated by these machines. Ensure all steps are taken to render the machine safe before attempting to work on the generator.

Caution, risk of electrical shock! The neutral conductor must be bonded to ground in accordance with the National Electrical Code, NFPA 70. This unit shall not be used in floating output applications.

GENERAL HAZARDS

For safety reasons, the manufacturer recommends that this equipment be installed, serviced and repaired by a Service Dealer or other competent, qualified electrician or installation technician who is familiar with applicable codes, standards and regulations. The operator also must comply with all such codes, standards and regulations.

Installation, operation, servicing and repair of this (and related) equipment must always comply with applicable codes, standards, laws and regulations. Adhere strictly to local, state and national electrical and building codes. Comply with regulations the Occupational Safety and Health Administration (OSHA) has established. Also, ensure that the generator is installed, operated and serviced in accordance with the manufacturer's instructions

and recommendations. Following installation, do nothing that might render the unit unsafe or in noncompliance with the aforementioned codes, standards, laws and regulations. Engine exhaust fumes contain carbon monoxide gas, which can be DEADLY. This dangerous gas, if breathed in sufficient concentrations, can cause unconsciousness or even death. For that reason, adequate ventilation must be provided. Exhaust gases must be piped safely away from any building or enclosure that houses the generator to an area where people, animals, etc., will not be harmed. This exhaust system must be installed properly, in strict compliance with applicable codes and standards.

Keep hands, feet, clothing, etc., away from drive belts, fans, and other moving or hot parts. Never remove any drive belt or fan guard while the unit is operating.

Adequate, unobstructed flow of cooling and ventilating air is critical to prevent buildup of explosive gases and to ensure correct generator operation. Do not alter the installation or permit even partial blockage of ventilation provisions, as this can seriously affect safe operation of the generator. Never install a generator indoors.

Keep the area around the generator clean and uncluttered. Remove any materials that could become hazardous. When working on this equipment, remain alert at all times. Never work on the equipment when physically or mentally fatigued.

GENERATOR INSTALLATION

These generators are air-cooled, engine-driven generator sets designed to supply electrical power that operates critical electrical loads during utility power failure. These generators are factory-installed in a weather resistant, all metal enclosure and are intended for outdoor installation only.

BEFORE INSTALLATION

The generator's rated wattage/ampere capacity must be adequate to handle all electrical loads that the unit will power. The critical priority loads may need to be grouped together and wired into a separate priority circuits distribution panel.

Each generator has a minimum fuel volume requirement. Refer to the owner's manuals for the generator fuel consumption. Verify that the natural gas meter presently installed at the house will support both the generator fuel load as well as any other gaseous appliances that will require fuel to operate if powered by the generator. If an LP application, verify that the fuel tank and pipe is large enough to sustain the necessary volume even during cold temperatures.

Connecting this generator to an electrical system normally supplied by an electric utility shall be by means of a transfer switch, so as to isolate the electric system from the utility distribution system when the generator is operating. Failure to isolate the electric system by these means will result in damage to the generator and may also result in injury or death to utility workers due to backfeed of electrical energy.

The engine-generator is to be installed over non-combustible materials and should be located such that combustible materials are not capable of accumulating under the generator set.

Only qualified, competent installation contractors or electricians thoroughly familiar with applicable codes, standards and regulations should install this standby electric power system. The installation must comply strictly with all codes, standards and regulations pertaining to the installation.

After the system has been installed, do nothing that might render the installation in non-compliance with such codes, standards and regulations.

NFPA STANDARDS

The following published standards booklets pertaining to standby electric systems are available from the National Fire Protection Association (NFPA), Batterymarch Park, Quincy, MA 02269:

NFPA No. 37,	STATIONARY COMBUSTION ENGINES AND GAS TURBINES
NFPA No. 54,	NATIONAL FUEL GAS CODE
NFPA No. 58,	LIQUIFIED PETROLEUM GAS CODE
NFPA 70,	National Electrical Code (NEC)
NFPA 99,	STANDARD FOR HEALTH CARE FACILITIES
NFPA 101,	LIFE SAFETY CODE
NFPA 110,	STANDARD FOR EMERGENCY AND STANDBY POWER SYSTEMS
NFPA 220,	STANDARD TYPES OF BUILDING CONSTRUCTION

NOTE: It is essential to use the latest version of any standard to ensure that the generator and its accessories comply with all the applicable standards and local codes.

OTHER PUBLISHED STANDARDS

In addition to NFPA standards, the following information pertaining to the installation and use of standby electric systems is available:

- Article X, NATIONAL BUILDING CODE, available from the American Insurance Association, 85 John Street, New York, N.Y. 10038.
- AGRICULTURAL WIRING HANDBOOK, obtainable from the Food and Energy Council, 909 University Avenue, Columbia, MO, 65201.
- ASAE EP-364.2, INSTALLATION AND MAINTENANCE OF FARM STANDBY ELECTRIC POWER, available from the American Society of Agricultural Engineers, 2950 Niles Road, St. Joseph, MI 49085.
- A52.1, AMERICAN NATIONAL STANDARDS FOR CHIMNEYS, FIREPLACES AND VENTING SYSTEMS, available from the American National Standards Institute, 1430 Broadway, New York, NY 10018.

The installer must comply with all applicable state and local codes.

GROUNDING THE GENERATOR

A grounding lug is provided on the generator mounting base for the purpose of grounding the frame and the external electrically conductive parts of this equipment to an approved earth ground and/or grounding rods where required by the National Electrical Code. Grounding procedures must meet local regulations.

BATTERY INSTALLATION

Standby generators installed with automatic transfer switches will crank and start automatically when NORMAL (UTILITY) source voltage is removed or is below an acceptable preset level. To prevent such automatic start-up and possible injury to personnel, do not connect battery cables until certain that normal source voltage at the transfer switch is correct and the system is ready to be placed into operation.

Storage batteries give off explosive hydrogen gas. This gas can form an explosive mixture around the battery for several hours after charging. The slightest spark can ignite the gas and cause an explosion. Such an explosion can shatter the battery and cause blindness or other injury. Any area that houses a storage battery must be properly ventilated. Do not allow smoking, open flame, sparks or any spark producing tools or equipment near the battery.

Battery electrolyte fluid is an extremely caustic sulfuric acid solution that can cause severe burns. Do not permit fluid to contact eyes, skin, clothing, painted surfaces, etc. Wear protective goggles, protective clothing and gloves when handling a battery. If fluid is spilled, flush the affected area immediately with clear water.

Do not dispose of the battery in a fire. The battery is capable of exploding.

Do not open or mutilate the battery. Released electrolyte can be toxic and harmful to the skin and eyes.

The battery represents a risk of high short-circuit current. When working on the battery, always remove watches, rings or other metal objects, and only use tools that have insulated handles.

VENTED BATTERIES

The electrolyte is a dilute sulfuric acid that is harmful to the skin and eyes. It is electrically conductive and corrosive. The following procedures are to be observed:

- Wear full eye protection and protective clothing.
- If electrolyte contacts the skin, wash it off immediately with water.
- If electrolyte contacts the eyes, flush thoroughly and immediately with water and seek medical attention. Spilled electrolyte is to be washed down with an acid-neutralizing agent. A common practice is to use a solution of one pound (500 grams) bicarbonate of soda to one gallon (4 liters) of water. The bicarbonate of soda solution is to be added until the evidence of reaction (foaming) has ceased. The resulting liquid is to be flushed with water and the area dried.

- Lead acid batteries present a risk of fire because they generate hydrogen gas. The following procedures are to be followed:
- DO NOT SMOKE when near batteries.
- DO NOT cause flame or spark in battery area.
- Discharge static electricity from body before touching batteries by first touching a grounded metal surface.
- Servicing of batteries is to be performed or supervised by personnel knowledgeable of batteries and the required precautions. Keep unauthorized personnel away from batteries.
- For recommended batteries, see the Installation Guide. All batteries must be at 100 percent state of charge before they are installed on the generator.
- It is important to check the specific gravity and electrolyte level. Have these procedures performed at the intervals specified in the "Maintenance" section in the Owner's Manual. A negative ground system is used. Battery connections are shown on the wiring diagrams. Make sure all batteries are correctly connected and terminals are tight. Observe battery polarity when connecting batteries to the generator set.

NOTE: Damage could result if the battery connections are made in reverse.

BEFORE YOU BEGIN

Contact the local inspector or City Hall to be aware of all federal, state and local codes that could impact the installation. Secure all required permits before starting the job.

Carefully read and follow all of the procedures and safety precautions detailed in the installation guide. If any portion of the installation manual, technical manual or other factory-supplied documents is not completely understood, contact a dealer for assistance.

Fully comply with all relevant NEC, NFPA and OSHA standards as well as all federal, state and local building and electric codes. As with any generator, this unit must be installed in accordance with current NFPA 37 and NFPA 70 standards as well as any other federal, state, and local codes for minimum distances from other structures.

SITE PREPARATION AND GENERATOR PLACEMENT



1. Locate the mounting area as close as possible to the transfer switch and fuel supply.

Leave adequate room around the area for service access (check local code), and place high enough to keep rising water from reaching the generator.

Choose an open space that will provide adequate and unobstructed airflow.



2. Place the unit so air vents won't become clogged with leaves, grass, snow or debris. Make sure exhaust fumes will not enter the building through eaves, windows, ventilation fans or other air intakes.
Dig a rectangular area approximately five inches deep and about six inches longer and wider than the footprint of the generator. Cover with polyurethane film and fill with pea gravel or crushed stone. Compact and level the stone. A concrete pad can be poured if desired.

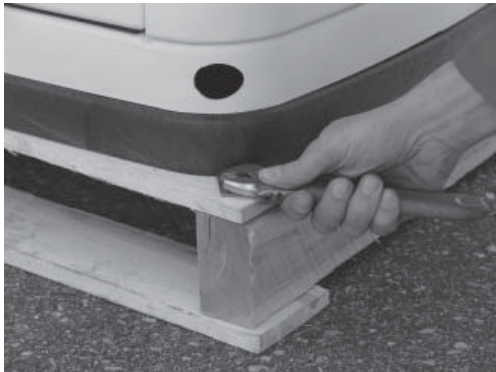

3. Inspect the generator for shipping damage and if necessary, file a claim with the shipper. Remove the bands holding the generator to the wooden pallet.



4. Make sure the lifting equipment to be used has sufficient capacity to safely handle the weight of the generator. Use nylon lifting straps and connect them to the lifting eyes on each corner of the base frame to avoid damaging the enclosure.



5. Set the generator onto the pad so that the gravel bed extends several inches beyond the generator on all sides. Make sure the generator is level within 1/2 inch.



6. Connect an approved ground strap to the grounding lug on the base frame and to an approved earth ground or grounding rod as specified by local regulations.
7. Check the engine oil and, if necessary, add enough of the recommended oil to bring the level up to the FULL mark on the dipstick. Be careful not to overfill the crankcase.

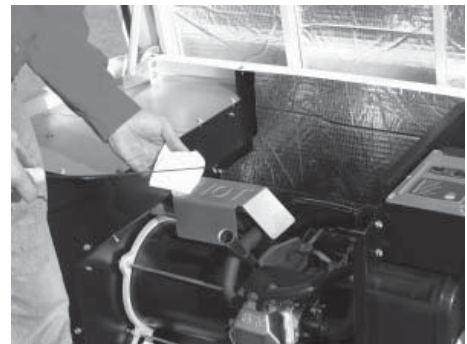

CONVERTING TO LP VAPOR



1. The generator was configured for natural gas operation at the factory. Switching over to LP Vapor is a simple procedure.

On models with a single cylinder engine, begin by disconnecting and removing the battery if installed.



2. Take the plastic T-handle fuel selector in the poly bag supplied with the generator and locate the selector tab on the air box cover. Insert the pin end into the hole in the selector tab and pull outward to overcome spring pressure. Then twist clockwise 90 degrees and allow the selector to return in once aligned with the LP position.

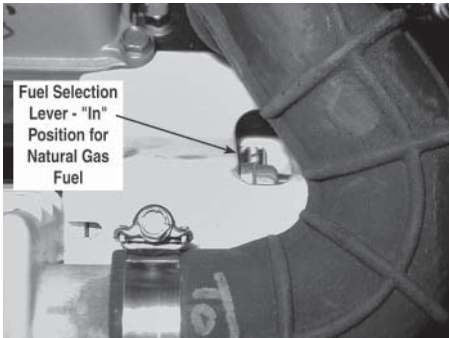

3. On 10 kW units, open the roof, loosen the forward clamp on the air inlet hose, and slide the hose away from the hose fitting.

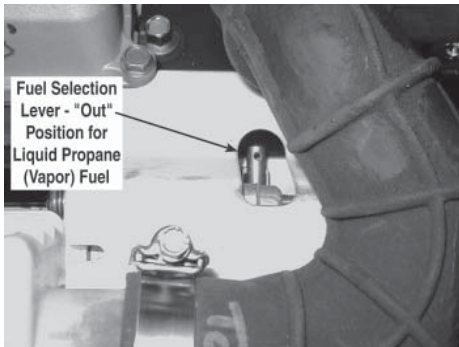

4. Slide the fuel selector pin on the carburetor out towards the back of the enclosure.
5. Replace the inlet hose and tighten the clamp securely.

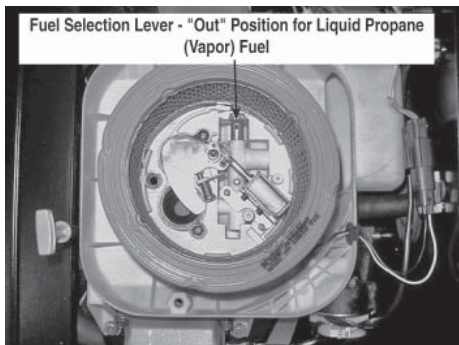

6. On all other models, simply remove the air cleaner cover and slide the fuel selector pin outward from the natural gas to the LP position.

INSTALLING & CONNECTING GAS LINES



1. Both natural gas and LP Vapor are highly volatile substances, so strict adherence to all safety procedures, codes, standards and regulations is essential. Gas line connections should be made by a certified plumber familiar with local codes. Always use AGA-approved gas pipe and a quality pipe sealant or joint compound. Verify the capacity of the natural gas meter or the LP tank in regards to providing sufficient fuel for both the generator and other operating appliances.



2. Most applications will require an external manual shutoff valve on the fuel line.



3. Where the gas line is to enter the generator, install a T-fitting to allow for gas pressure monitoring. On one opening of the fitting install a 1/4" NPT nipple and threaded plug. In some cases a sediment trap may also be installed.



- When connecting the gas line to the generator, use the provided section of UL Listed or AGA-approved flexible fuel line in accordance with local regulations. The purpose of the flexible fuel line is to ensure that vibration from the generator does not cause a gas leak at one of the connection points, so it's important that the line be installed with as few bends as possible.



- When finished checking the gas pressure, close the manual shutoff valve.

BATTERY CHARGER INSTALLATION



- Never bend the flexible fuel line to avoid using an elbow. Bending the flexible line decreases its ability to absorb vibrations and defeats its purpose as well as constricts the actual fuel flow.



- If the generator came with a separately packaged battery charger, it may be necessary to install the charger, either in the generator or in the transfer switch. Refer to documentation included with the battery charger for installation and wiring of the battery charger. For applications with RTSN, RTSE and GenReady transfer switches the charger needs to be mounted in the generator. Refer to documentation included with the battery charger for installation and wiring of the battery charger.



- After checking for leaks, check the gas pressure at the T-fitting installed earlier to make sure there's enough pressure for proper generator operation. The local gas supplier is responsible for ensuring adequate pressure, so if the pressure is too low, or if it's greater than 14 inches of water column, contact the gas supplier.

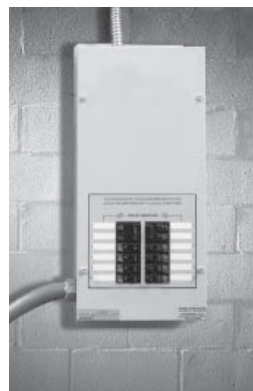

- For applications with RTS Load Center switches and RTSS Load Shed transfer switches the charger has already been installed in the transfer switch. Discard the separately packaged battery charger that came with the generator.

EXTERNAL ELECTRICAL CONNECTIONS



1. Drill a 1 ¼ inch hole and feed the conduit through the hole.

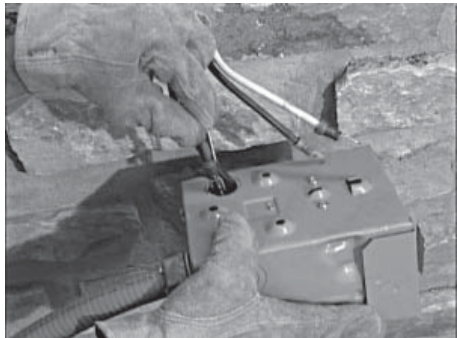

2. Remove the knockout in the back of the connection box, feed the wires through the back of the box and secure the conduit with the lock nut. Seal the hole with silicone caulk. Don't forget to caulk the hole inside the house as well.



3. Mount the connection box so that it completely covers the hole in the wall. Caulk around the sides and top of the box to ensure a good seal. Connect all wires to the lugs in the connection box (black to black, red to red and white to white). Attach the green ground wire to the ground screw and connect the two small plugs to their mating receptacle ends



4. Replace the protective cover plate and retaining screw, and lock the connection box.



5. For 10-20 kW models, locate the metal hasp that is packaged in the owner's manual bag. Insert the hasp in the slot located on the left side of the external circuit breaker box. Be sure that the clip of the hasp is facing toward the front of the generator. If desired, lock the external box.

GENERATOR CONNECTIONS – RTS LOAD CENTER TRANSFER SWITCH



1. If the generator comes with an external connection box and 5' seal-tite whip pre-wired and connected to the generator, no additional connections are necessary at the generator. Skip the following section and proceed with Appendix A, RTS Pre-Wired Load Center Transfer Switch Installation & Operational Testing.



2. If the RTS Load Center transfer switch was purchased separately from the generator, the 5' seal-tite whip will need to be connected to the generator. To complete the wiring, run the ¾" conduit for the power leads and control wires from the external connection box to the generator.



3. Remove the two screws securing the connection area cover, and remove the cover.



4. Feed the wires through the back of the generator and secure the conduit with the lock nut.

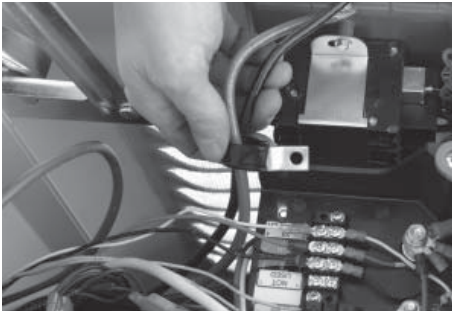

5. Run the power leads through the strain relief provided.

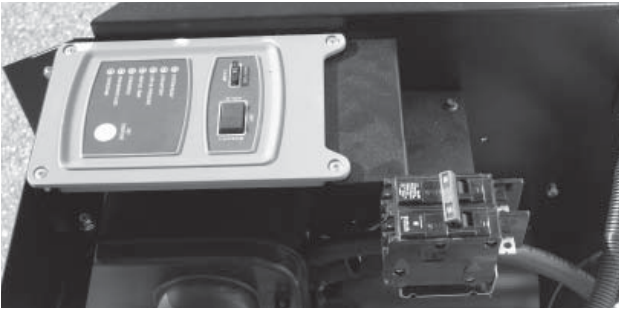

6. On 8 kW units, the main breaker is located inside the generator at the rear of the connection area.



7. For all other models the circuit breaker is attached to the exterior access panel.



8. Remove the plastic plugs inside the main breaker access area to allow connection of the power leads to the circuit breaker.



9. Now connect the red and black power leads to the circuit breaker. Since this is a single-phase application, it doesn't matter which wire is connected to which lug.

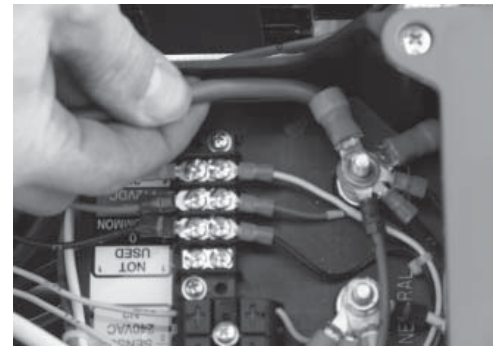

10. Connect the green equipment ground wire to the ground stud and torque to 100 inch lbs.

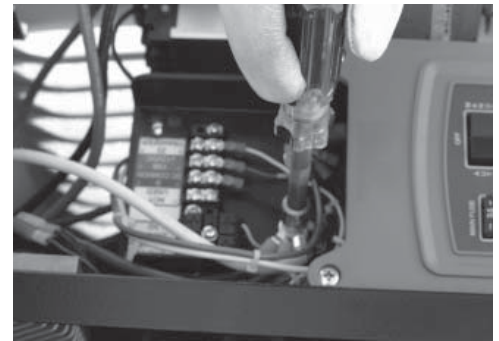

11. Connect the white neutral wire to the neutral post and torque to 100 inch lbs.

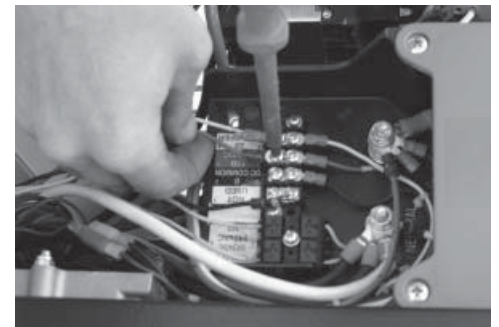

12. Connect the control wires to the correct terminals. The terminals are clearly marked N1, N2, 23 and 15B. If connecting a pre-wired switch a 0 (zero) wire will also be required.

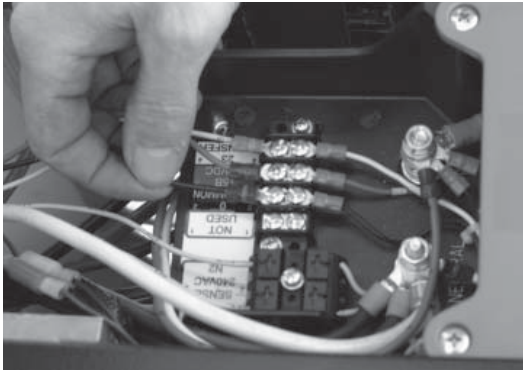

13. If the battery charger was factory mounted in the transfer switch, 0 (zero) will also need to be connected between the generator and transfer switch.
14. An improperly connected control wire can damage the generator control board.

**APPENDIX A – RTS PRE-WIRED
LOAD CENTER TRANSFER SWITCH
INSTALLATION & OPERATIONAL TESTING**

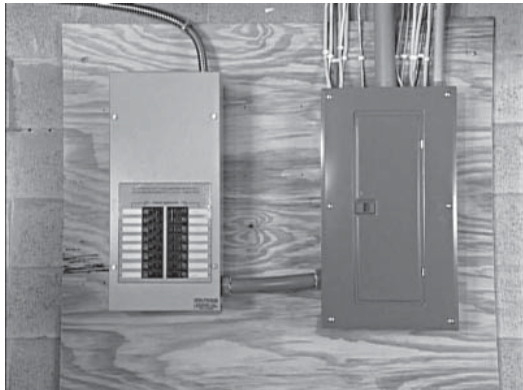

1. Before beginning any installation, make sure power is shut OFF to the main distribution panel and carefully read the Owner's Manual that came with the transfer switch. The distributed load center switch must be mounted close enough to the main distribution panel to accommodate the two-foot, pre-wired conduit. Make sure no water or corrosive substances can drip onto the transfer switch enclosure.



2. Always inspect the switch for shipping damage. Never mount a transfer switch that shows any evidence of damage.

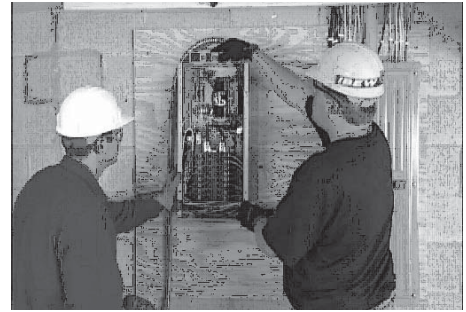

3. Protect against impact and mount the switch vertically to a rigid support structure. Make sure the switch is level and plumb. The transfer switch is an open transition switch. Open transition switches prevent electrical feedback between the generator and the utility by only allowing load circuits to be connected to one power supply at a time.



4. Each wire in the pre-wired transfer switch is color-coded to easily match circuits in the main panel to their new breakers in the transfer switch.



5. When three-conductor wiring is used, two 120 volt circuits will often share the same neutral wire. To avoid overloading the neutral, either move BOTH of the circuits that share the neutral or don't move either of them.



6. When moving two circuits with a shared neutral, they should be connected to adjacent positions (one above the other) in the transfer switch. That will assure that the two hot wires are on separate phases and will maintain their relationship to neutral.

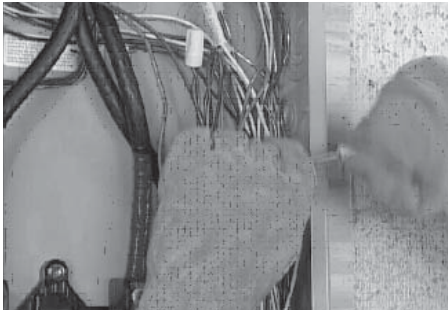

7. Choose a circuit to be backed up and remove the power lead from the breaker.

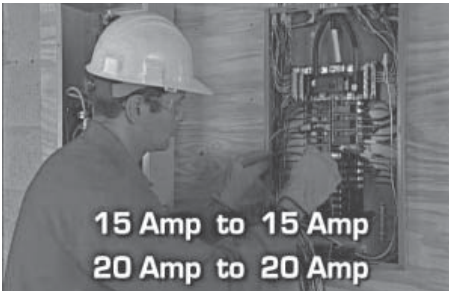

8. Using UL Listed wire nuts, reconnect the power lead to a matching breaker in the transfer switch.



9. Make sure each circuit moved is protected by the same size breaker in the transfer switch. 15 Amp circuits must be connected to 15 Amp breakers and 20 Amp circuits to 20 Amp breakers.



10. Connect the provided large neutral to the neutral bar in the distribution panel.



11. Install a 2-pole breaker in the distribution panel to protect the transfer switch. The required amp rating of the breaker depends on which transfer switch is used. If installing an 8-circuit, pre-wired load center switch, the breaker cannot exceed 40 Amps. For all other pre-wired load center switches the breaker cannot exceed 70 Amps. This breaker must be compatible with the existing electrical distribution panel.

Install the breaker in two adjacent empty slots (one above the other) in the main panel.



12. When all priority circuits have been moved to the transfer switch, close the main breaker to restore utility power and make sure utility voltage at the transfer switch is correct. Refer to NFPA 70-E for the safety equipment required when working inside a live transfer switch.



13. Before purchasing a battery for the generator, refer to the generator Owner's Manual for a list of recommended batteries. Follow all of the procedures and safety precautions in the Owner's Manual when installing the battery.

BATTERY INSTALLATION



1. Before purchasing a battery for the generator, refer to the Owner's Manual for the recommended battery.
 - 8 kW: Group 26R, 12 Volt, 350cca minimum
 - 10-20 kW: Group 26R, 12 Volt, 525cca minimum

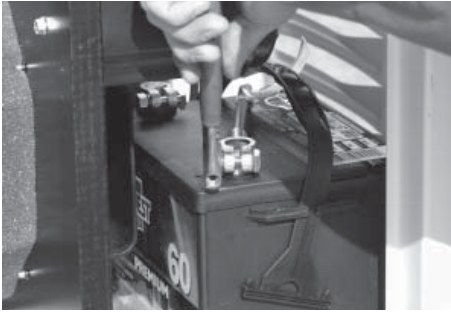

2. Follow all of the procedures and safety precautions in the generator Owner's Manual when installing the battery. Verify the switch is in the off position. When preparing for operational testing, DO NOT connect the battery until transfer switch connections are complete.

OPERATIONAL TESTING



1. Switch the generator's main circuit breaker OFF and put the mode switch in the OFF position.

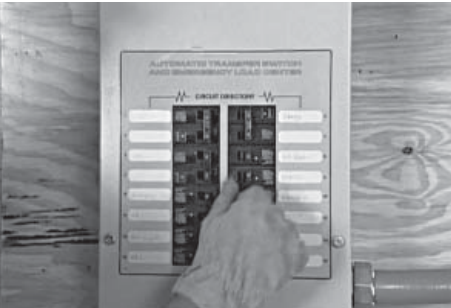

2. Make sure utility power is OFF and place all of the priority circuit breakers in the transfer switch in the OFF position.

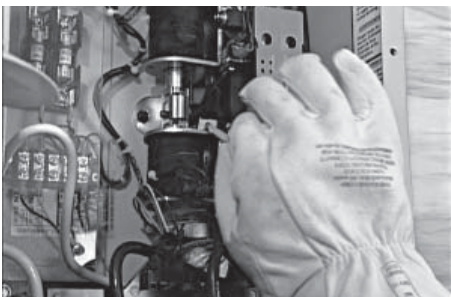

3. Locate the transfer handle, insert the metal end into the slot in the main contactor assembly and pull the handle DOWN to move the main contacts to the standby power, or generator position.
NEVER OPERATE THE TRANSFER SWITCH MANUALLY WHEN LOADS ARE CONNECTED.

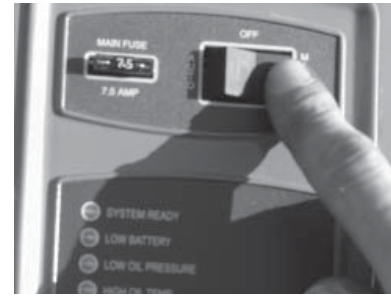

4. Put the generator's mode switch in MANUAL to start the engine. Allow the engine to warm up, then switch the generator's main breaker to the ON position. The generator is now supplying electricity to the transfer switch but is not carrying any load.



5. For all models except the 8 and 10kW check to be sure that voltage and frequency from the generator is correct. If line-to-line voltage is not approximately 240 volts, refer to the Owner's Manual for the proper adjustment procedures. On all models, if line-to-neutral voltage is not 120 volts, check the neutral connection between the generator and transfer switch.

For 8 kW models check to be sure that the frequency from the generator is correct. If the frequency is not approximately 60Hz, refer to the generator Owner's Manual for the proper adjustment procedure.



6. When finished checking the voltage, switch the generator's main circuit breaker OFF and put the mode switch in the OFF position to shut down the generator.



7. Make sure the 2-pole circuit breaker installed in the main distribution panel is in the OFF position.



8. Use the transfer handle to move the main contacts in the transfer switch to the UP (utility position). Switch the 2-pole breaker ON in the distribution panel.



9. Now switch the generator's main breaker ON, and put the mode switch in AUTO.



10. Shut OFF utility power and make sure the generator starts automatically.



11. If everything worked properly, switch the main breaker to ON and make sure that power is automatically transferred back to the utility.



12. After the engine has completed its cool down cycle and shut down, shut OFF utility power again. When the generator is supplying power to the transfer switch, move the breakers in the switch to the ON position, one at a time, until the generator has accepted the entire priority load.



13. With the generator carrying the entire priority load, recheck gas pressure to verify that it is at the same level it was before the generator was started.

NOTE: Even if the generator is running smoothly at this point, a drop in gas pressure indicates that the supply is barely adequate to supply the generator's needs. Changes in the generator load, or additional gas demand by other appliances may affect the generator's performance. Verify gas pressure and pipe sizing. Unhook the manometer and reinstall the port plug.



14. Switch the main breaker ON to restore utility power. The generator will continue to run to allow the engine to cool down before shutting itself off. Shut off utility power again. The generator should start and the entire priority load should transfer to the generator. Close the main breaker to restore utility power and allow the engine to cool down and shut itself off.



15. Operational tests are now complete. Refer to – Setting the Automatic Exercise Function to complete the installation.

APPENDIX B – RTSN AND RTSE TRANSFER SWITCH INSTALLATION & OPERATIONAL TESTING

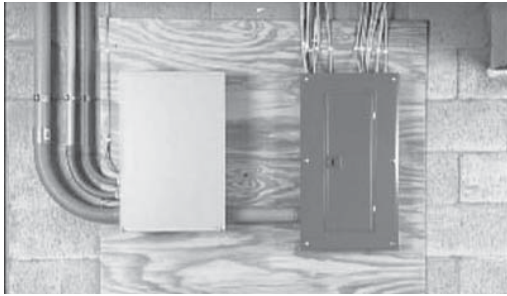

1. Before beginning any installation, make sure power is shut OFF to the main distribution panel and carefully read the Owner's Manual that came with the transfer switch. To simplify the installation process, the transfer switch should be mounted as close to the main distribution panel as possible. Make sure no water or corrosive substances can drip onto the transfer switch enclosure.



2. Always inspect the switch for shipping damage. Never mount a transfer switch that shows any evidence of damage.

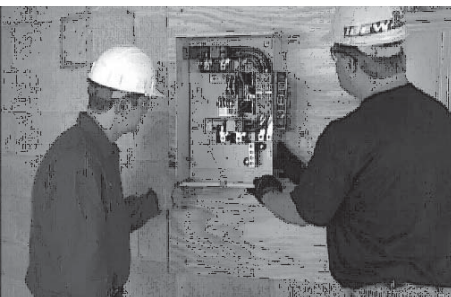

3. Protect against impact and mount the switch vertically to a rigid support structure. Make sure the switch is level and plumb. Check local codes before wiring the transfer switch. Some jurisdictions require that wiring inside the switch be done by a licensed electrician.



4. All wiring must be the correct size and type, and must conform to all codes, standards and regulations. Refer to the transfer switch Owner's Manual and the National Electrical Code for additional information.



5. As with any product, design changes can occur over time, so always refer to the schematics in the transfer switch Owner's Manual for the required connections and safety precautions.

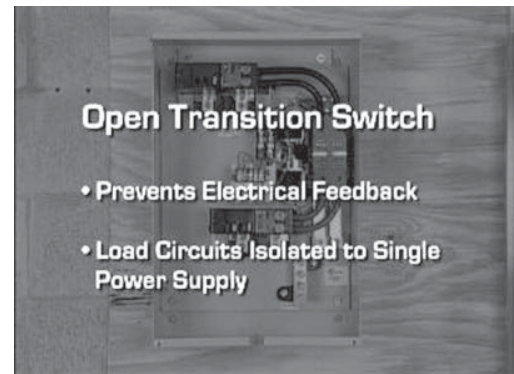

6. The transfer switch being used is an open transition switch. Open transition switches prevent electrical feedback between the generator and the utility by only allowing load circuits to be connected to one power supply at a time.

SELECTED CIRCUIT COVERAGE

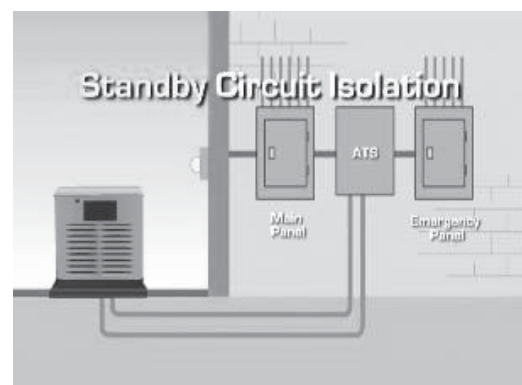

1. The generator powers only designated circuits that are grouped together and wired into a separate priority distribution panel. The transfer switch is installed between the main distribution panel and the priority panel. The amperage rating of the transfer switch must be equal to or greater than the highest amperage rating of the utility and generator breakers feeding the switch.

WHOLE-HOUSE CIRCUIT COVERAGE

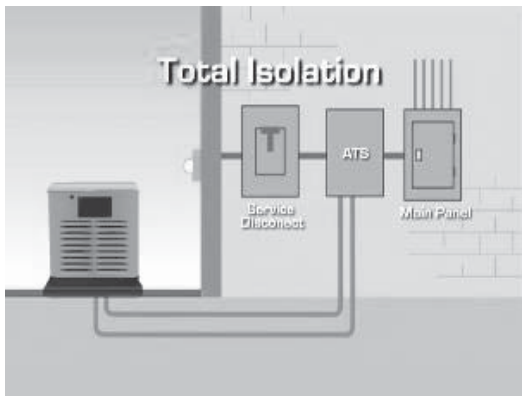

1. The generator will be backing up all electrical loads within the panel, so the amperage rating of the transfer switch must be equal to or greater than the amperage rating of the normal utility service.

Unless a service entrance rated transfer switch is used, a main service disconnect must be located before the transfer switch. The transfer switch must be installed between the utility service entrance and the building distribution panel.

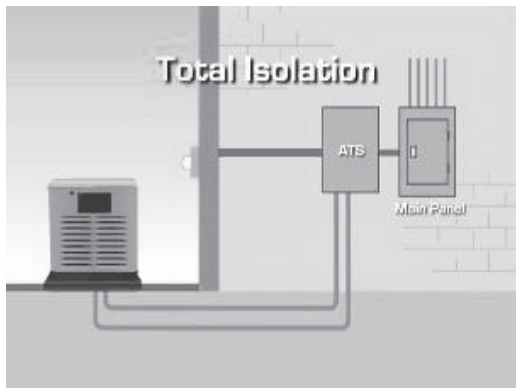

2. A service entrance rated transfer switch is installed between the service entrance and the main distribution panel. The service entrance rated switch becomes the main service so no service disconnect is needed. The existing main distribution panel becomes a sub-panel.

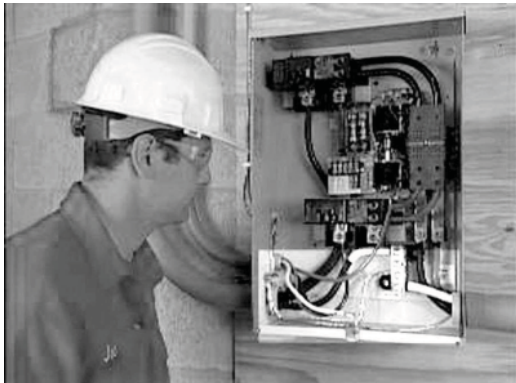

3. The grounding that is normally in the main panel must be accomplished in the service entrance rated switch and must be disconnected in the existing distribution panel. Refer to the National Electrical Code (NEC) for complete information on grounding and bonding.

BATTERY CHARGER INSTALLATION

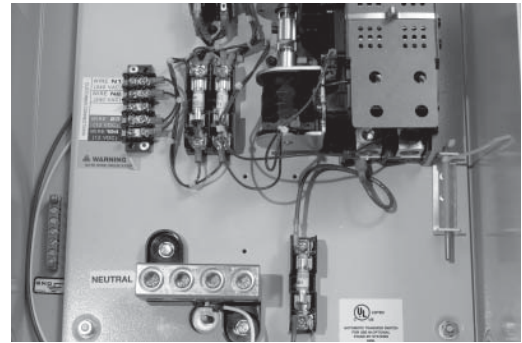

1. The battery charger is to be installed in the generator when using an RTSN or RTSE transfer switch. Refer to the Battery Charger Installation Guide for details.

ELECTRICAL CONNECTIONS



1. Connect the power leads from both the generator and the utility to the appropriate lugs in the transfer switch. The lugs are clearly marked in the switch.
N = Normal Utility Supply
E = Generator Connection Panel
T = Load Distribution Panel



2. Neutral wires from both the utility and the generator are connected to the same neutral lug in the switch.

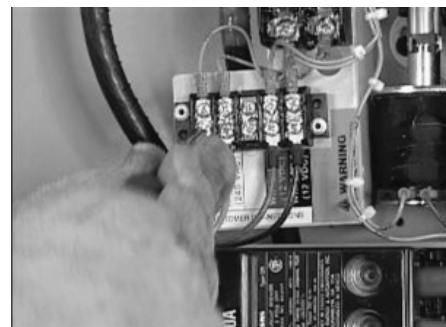

3. Connect the control wires from the generator to the terminal block in the transfer switch. The terminals are marked N1, N2, 23 and (194 or 15B). If the fourth terminal in the transfer switch is labeled 194, wire 15B from the generator will connect to terminal 194 in the transfer switch.



4. Complete the transfer switch wiring by connecting the equipment ground wires from both the utility and the generator to the ground lug.



5. Being careful to support the lugs, torque the lugs in the transfer switch to the specifications shown on the transfer switch. Decal located on the inside of the switch door.

OPERATIONAL TESTING



1. If installing the RTSE switch, the service was changed so make sure the terminations are good before re-energizing the utility.



2. Switch the main utility breaker OFF. Refer to NFPA 70-E for the safety equipment required when working inside a live transfer switch.



3. Energize the utility and check line-to-line and line-to-neutral voltage at terminals N1 and N2 on the transfer contactor. If line-to-line voltage is not approximately 240 volts, de-energize utility power and check the terminations between the utility and N1 and N2. If line-to-neutral voltage is not approximately 120 volts, de-energize utility power and check the neutral terminations. Repeat the same voltage checks on terminals T1 and T2 to make sure current is flowing properly through the contactor.



4. Switch the generator's main circuit breaker OFF and put the mode switch in the OFF position.



5. Make sure utility power is OFF and place all of the individual circuit breakers in the main distribution panel in the OFF position.



6. Locate the transfer handle, insert the metal end into the slot in the main contactor assembly. Pull the handle DOWN to move the main contacts to the standby power (generator) position.
NEVER OPERATE THE TRANSFER SWITCH MANUALLY WHEN LOADS ARE CONNECTED.



7. Put the generator's mode switch in MANUAL to start the engine.
Allow the engine to warm up, then switch the generator's main breaker to the ON position. The generator is now supplying electricity to the transfer switch but is not carrying any load.



8. For all models except the 8 and 10 kW check to be sure that voltage and frequency from the generator is correct. If line-to-line voltage is not approximately 240 volts, refer to the generator Owner's Manual for the proper adjustment procedures. On all models, if line-to-neutral voltage is not approximately 120 volts, check the neutral connection between the generator and transfer switch. For 8 kW models check to be sure that the frequency from the generator is correct. If the frequency is not approximately 60Hz, refer to the generator Owner's Manual for the proper adjustment procedure.



9. Switch the generator's main circuit breaker OFF and put the mode switch in the OFF position to shut down the generator.



10. With utility power still OFF, use the transfer handle to move the main contacts to the UP (utility) position.



11. Close the main breaker to turn utility power ON.



12. Switch the generator's main breaker to the ON position and put the mode switch in AUTO.



13. Shut OFF utility power and make sure the generator starts automatically after the line interrupt delay.



- Switch the utility breaker to ON and make sure that power is automatically transferred back to the utility.



- Shut OFF utility power again to automatically start the generator. When power has transferred to the generator, close each of the breakers in the distribution panel one at a time until the generator has accepted the entire load.

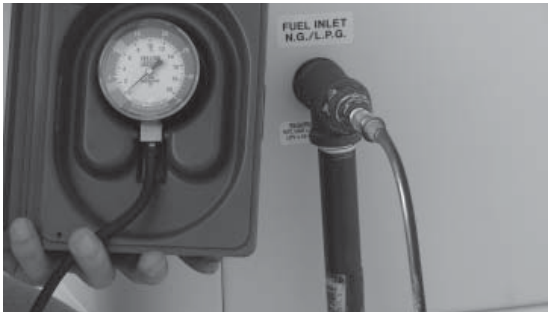

- With the generator carrying the entire load, recheck gas pressure to verify that it's at the same level it was before the generator was started.

NOTE: Even if the generator is running smoothly at this point, a drop in gas pressure indicates that the supply is barely adequate to supply the generator's needs. Changes in the generator load, or additional gas demand by other appliances may affect the generator's performance. Verify gas pressure and pipe sizing. Unhook the manometer and reinstall the port plug.



- Switch the utility breaker ON to restore utility power to the home.



- The generator will continue to run to allow the engine to cool down, then shut itself off.
- Shut OFF utility power again. The generator should start and the entire priority load should transfer to the generator.



- Close the main breaker to restore utility power and allow the engine to cool down and shut itself off. Operational tests are now complete. Refer to – Setting the Automatic Exercise Function to complete the installation.

APPENDIX C – POWERMASTER™ LOAD CONTROLLER INSTALLATION AND OPERATIONAL TESTING



- The PowerMaster load controller should be mounted as close to the main distribution panel as possible to avoid splicing. Refer to the instructions and wiring diagram in the PowerMaster Technical Manual before beginning the installation.

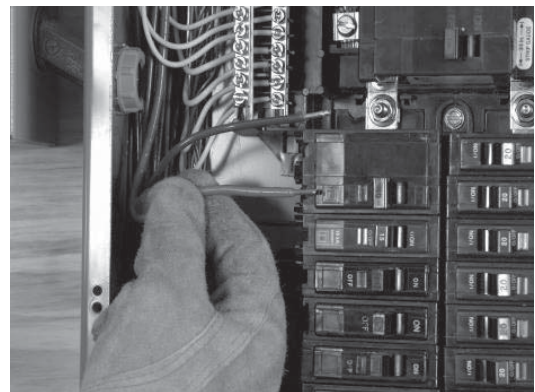

- After making sure that all power supplies are shut off, remove the power leads from the 240 volt, 2-pole breaker that controls the selected appliance.

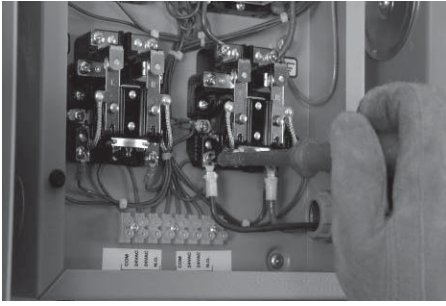

- Using the ring lugs provided and the wire specified in the PowerMaster Technical Manual, connect one end of new power leads to one of the contactors in the load controller.

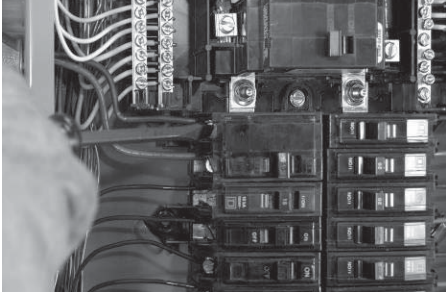

- Connect the other end of the new power leads to the appliance breaker in the distribution panel.

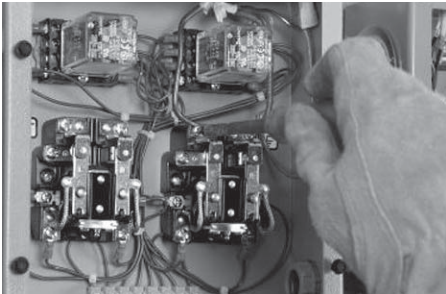

- Connect the power leads that were removed from the appliance breaker to the load terminals in the controller.

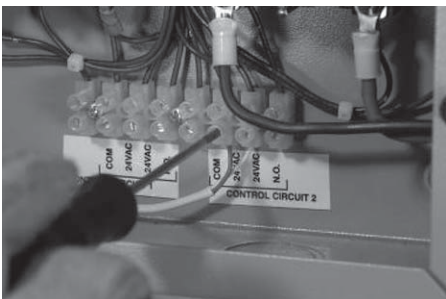

- Now run 24 volt control wires from the air conditioning circuit to the terminal strip in the controller.

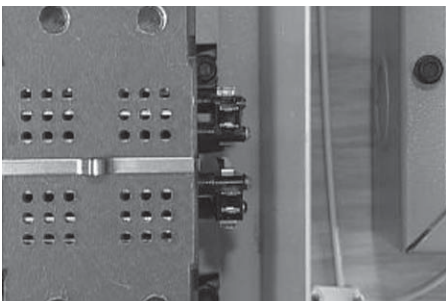

- The auxiliary switches that came with the controller must be installed in the transfer switch. These switches ensure that the controller will only disconnect the selected appliances when utility power is off and the generator is running. Refer to the Technical Manual for specific instructions for installing the auxiliary switches.

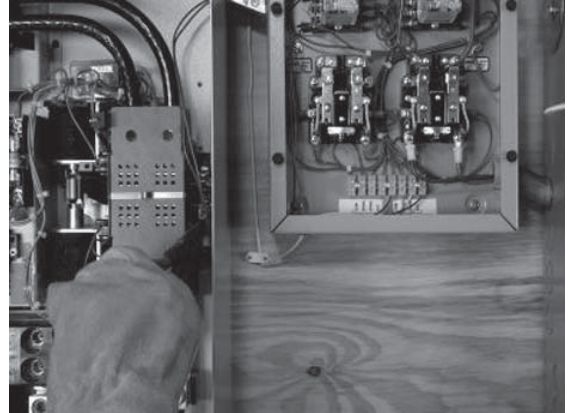

- Connect one end of two control wires to the COMMON and NORMALLY OPEN pins on the generator side of the transfer switch.

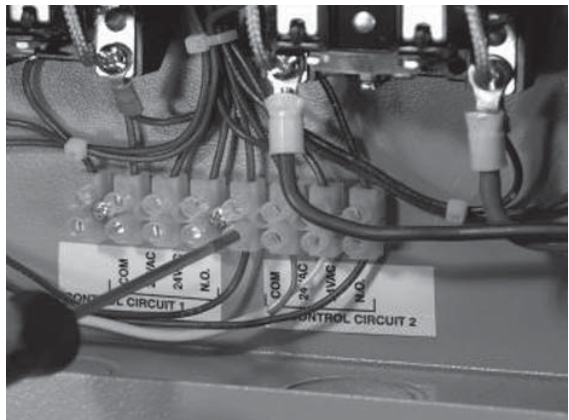

- Connect the other ends of the control wires to the COMMON and NORMALLY OPEN positions of the selected control circuit in the controller. If moving a second load to the controller, follow the same procedure.

OPERATIONAL TESTING



- Switch the generator's main circuit breaker OFF and put the mode switch in the OFF position.



2. If using a service entrance rated transfer switch, put the generator disconnect switch in the ON position if applicable.



3. Make sure utility power is OFF and place all of the individual circuit breakers in the main distribution panel in the OFF position.



4. Locate the transfer handle and insert the metal end into the slot in the main contactor assembly. Pull the handle DOWN to move the main contacts to the standby power (generator) position. NEVER OPERATE THE TRANSFER SWITCH MANUALLY WHEN LOADS ARE CONNECTED.



5. Put the generator's mode switch in MANUAL to start the engine. Allow the engine to warm up, then switch the generator's main breaker to the ON position. The generator is now supplying electricity to the transfer switch but is not carrying any load.



6. Check voltage and frequency from the generator. If line-to-line voltage is not 240 volts, refer to the Installation Guide for the proper adjustment procedures. If line-to-neutral voltage is not 120 volts, check the neutral connection between the generator and transfer switch. Switch the generator's main circuit breaker OFF and put the mode switch in the OFF position to shut down the generator.



7. With utility power still OFF, use the transfer handle to move the main contacts to the UP (utility) position.



8. Close the main breaker to turn utility power ON.



9. Switch the generator's main breaker to the ON position and put the mode switch in AUTO.



10. Shut OFF utility power and make sure the generator starts automatically.



14. Switch the utility breaker ON to restore utility power to the home.



11. Switch the utility breaker to ON and make sure that power is automatically transferred back to the utility.



15. The generator will continue to run to allow the engine to cool down before shutting itself OFF.



12. Shut OFF utility power again to automatically start the generator. When power has transferred to the generator, close each of the breakers in the distribution panel one at a time until the generator has accepted the entire load.



16. Unhook the gas meter and reinstall the port plug on the regulator.



13. With the generator carrying the entire load, re-check gas pressure to verify that it's at the same level it was before the generator was started.



17. Shut OFF utility power again. The generator should start and the entire emergency load should transfer to the generator. Close the main breaker to restore utility power and allow the engine to cool down and shut itself OFF. If everything worked properly, the generator is now ready for automatic operation.

CHECKING THE PRIORITY LOAD CONTROLLER



1. With utility power ON, make sure the central air conditioner will not start.

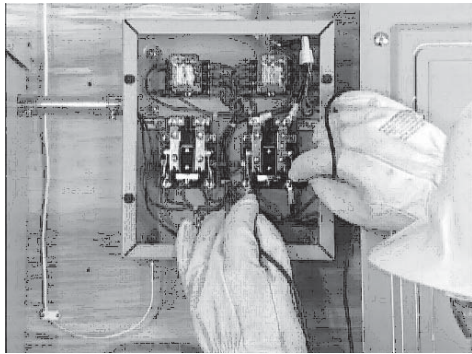

2. Using a multi-meter, make sure both the line and load sides of the contactors in the controller register 240 volts, and that the contactors are in the CLOSED position.

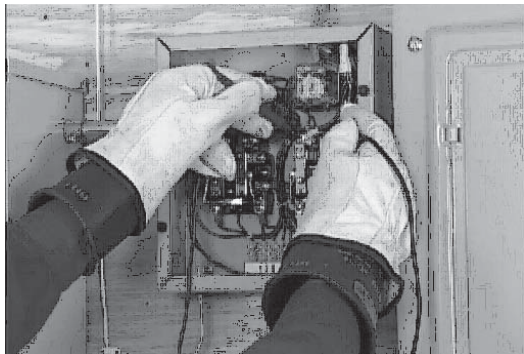

3. Start the central air conditioner and make sure the appliances selected are still working properly.



4. Make sure the central air conditioner will not start and simulate a power outage by shutting OFF utility power.



5. When the generator is carrying the entire load, check the voltage on the load side of the contactors to be sure the appliances connected to the controller are working properly.



6. With the generator still carrying the load, start the central air conditioner.

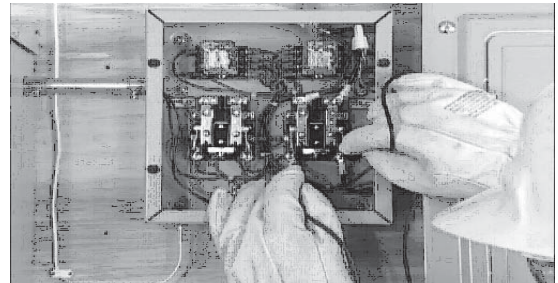

7. Check load side voltage again to be sure the selected appliances will not operate. Shut OFF the central air conditioner and re-check both line and load voltage to the selected appliances to be sure they are working again.



8. Turn the utility breaker back ON to restore utility power to the home.



- The generator's engine will continue to run through a cool down period before shutting itself OFF.
If everything worked properly, the generator is now ready for automatic operation.

APPENDIX D – POWER MANAGER LOAD SHED TRANSFER SWITCH INSTALLATION AND OPERATIONAL TESTING



- Before beginning any installation, make sure power is shut OFF to the main distribution panel and carefully read the Owner's Manual that came with the transfer switch. To simplify the installation process, the transfer switch should be mounted as close to the main distribution panel as possible. Make sure no water or corrosive substances can drip onto the transfer switch enclosure.
- Always inspect the switch for shipping damage. Never mount a transfer switch that shows any evidence of damage.



- Protect against impact and mount the switch vertically to a rigid support structure. Make sure the switch is level and plumb.



- Check local codes before wiring the transfer switch. Some jurisdictions require that wiring inside the switch be done by a licensed electrician.



- All wiring must be the correct size and type, and must conform to all codes, standards and regulations. Refer to the transfer switch Owner's Manual and the National Electrical Code (NEC) for additional information. As with any product, design changes can occur over time, so always refer to the schematics in the transfer switch Owner's Manual for the required connections and safety precautions.

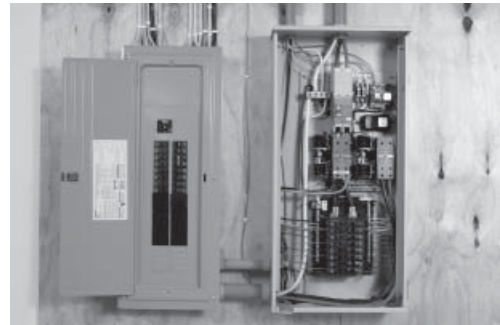

- The transfer switch being used is an open transition switch. Open transition switches prevent electrical feedback between the generator and the utility by only allowing load circuits to be connected to one power supply at a time.

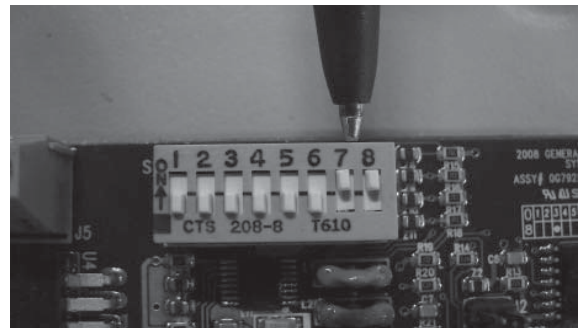

- Locate the dip switches on the transfer switch control board and set them for the desired load shed delay as instructed in the transfer switch owner's manual.



- The grounding that is normally in the main panel must be accomplished in the Power Manager Load Shed transfer switch and must be disconnected in the existing distribution panel. Refer to the National Electrical Code (NEC) for complete information on grounding and bonding.

BATTERY CHARGER INSTALLATION



- The battery charger is factory installed in the transfer switch.

ELECTRICAL CONNECTIONS



- Connect the utility power leads from the meter to the Utility circuit breaker in the transfer switch.

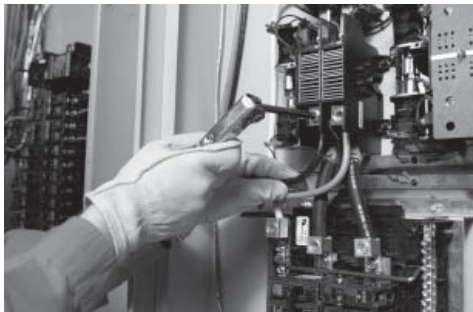

- Connect the generator power leads to the E1 and E2 terminals on the transfer switch contactor.

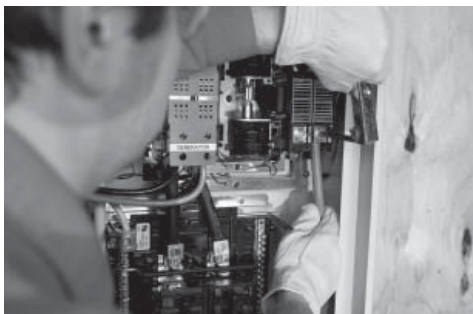

- Connect the customer non-priority load leads to the E1 and E2 terminals on the load shed contactor.



- Be careful to support the lugs and torque the lugs in the transfer switch to the specifications shown in the transfer switch Owner's Manual.



- Neutral wires from the utility, generator and shedding panel are connected to the same neutral lug in the switch.

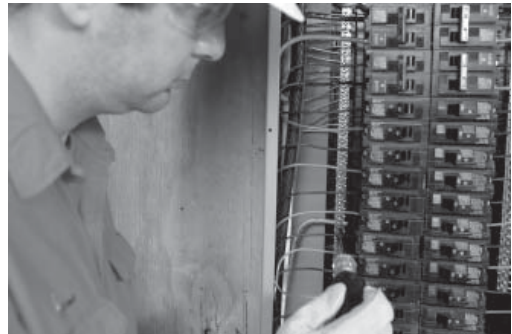

- In this step, move priority load circuits, which will always be backed up by the generator, from the existing electrical distribution panel to the 16 circuit load center in the Power Manager Load Shed switch.



- Select a priority circuit to be backed up and remove the power lead from the breaker.

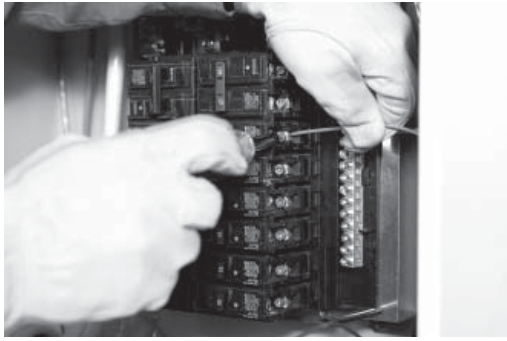

8. Reconnect the power lead to a matching breaker on the load center.



9. Make sure each circuit moved is protected by the same size breaker in the transfer switch. 15 Amp circuits must be connected to 15 Amp breakers and 20 Amp circuits to 20 Amp breakers.



10. When three-conductor wiring is used, two 120 volt circuits will often share the same neutral wire. To avoid overloading the neutral, either move BOTH of the circuits that share the neutral or don't move either of them.

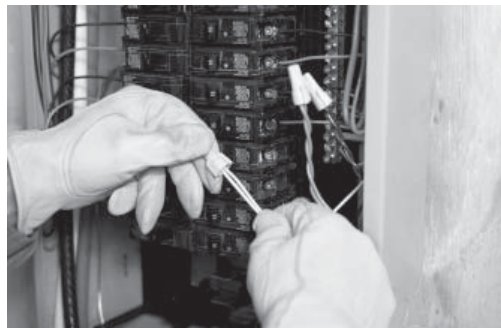

11. When moving two circuits with a shared neutral, they should be connected to adjacent positions (one above the other) on the load center. That will assure that the two hot wires are on separate phases and will maintain their relationship to neutral.

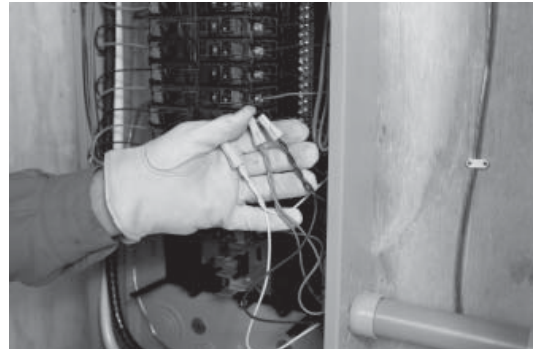

12. Remember that for every circuit moved from the main panel to the load center, the neutral will need to be relocated to the load center as well.

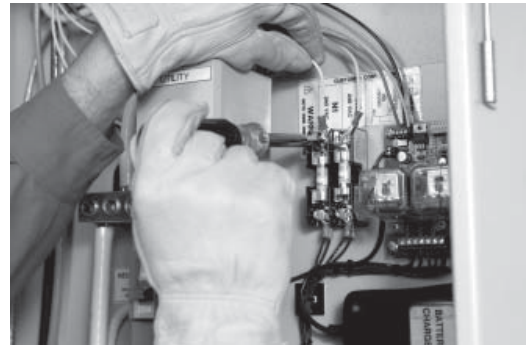

13. Connect the control wires from the generator to the terminal block in the transfer switch. The terminals are marked N1, N2, 23, 15B, and 0.



14. Complete the transfer switch wiring by connecting the equipment ground wire from the generator to the ground lug.



15. Close the Utility circuit breaker to restore utility power and make sure utility voltage at the transfer switch is correct. Refer to NFPA 70E for the safety equipment required when working inside a live transfer switch.

OPERATIONAL TESTING



1. Before energizing utility power to the service, make sure the main breaker is in the open (OFF) position.



2. Next, make sure all of the individual circuit breakers in both the priority load center and in the non-priority sub-panel, are in the OFF position. If the sub-panel has a primary breaker, make sure it is in the OFF position as well.



3. Locate the yellow transfer handle, insert the metal end into the slot for the transfer switch contactor assembly and move it UP into the UTILITY position.

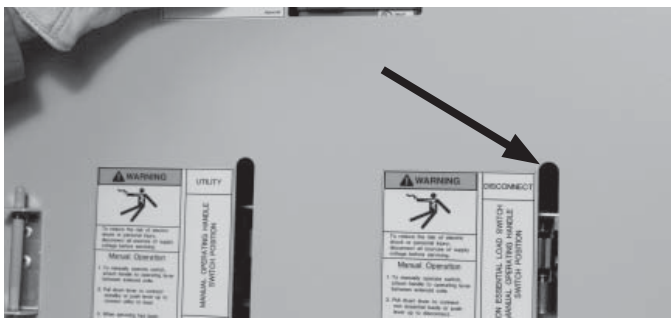

4. Next, insert the transfer handle into slot in the non-essential load shed switch assembly and move the contactor DOWN into the closed position. NEVER OPERATE THE TRANSFER SWITCH MANUALLY WHEN LOADS ARE CONNECTED.



5. With the main breaker OFF, energize the utility and check the voltage at terminals N1 and N2 on the transfer contactor. If utility voltage is not approximately 240 volts, de-energize utility power and check all of the terminations between the utility and N1 and N2.

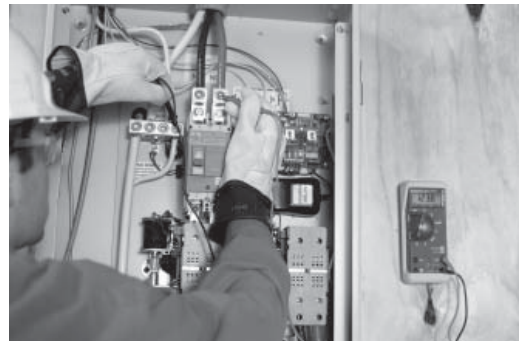

6. Check line-to-neutral voltage on N1 and N2. If voltage is not approximately 120 volts, de-energize utility power and check all of the neutral terminations between the utility and N1 and N2.



7. With all branch circuit breakers still OFF, close the main breaker by switching it to the ON position.

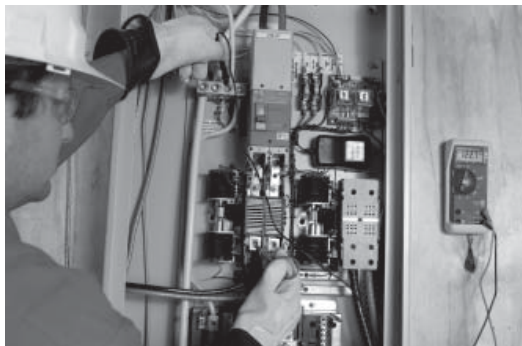

8. Check line-to-line voltage on terminals T1 and T2. If line-to-line voltage is not approximately 240 volts at any point in the system, switch the main breaker OFF and check terminations.

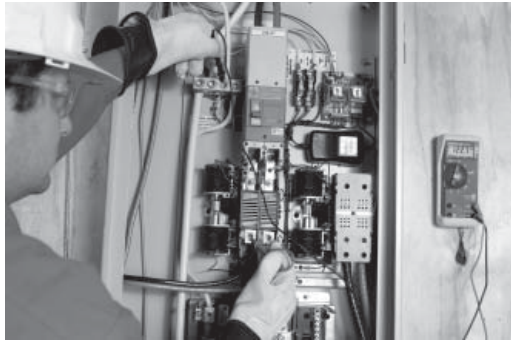

- Next, make sure line-to-neutral voltage at T1 and T2 is approximately 120 volts. If line-to-neutral voltage is not approximately 120 volts at any point in the system, check neutral terminations.

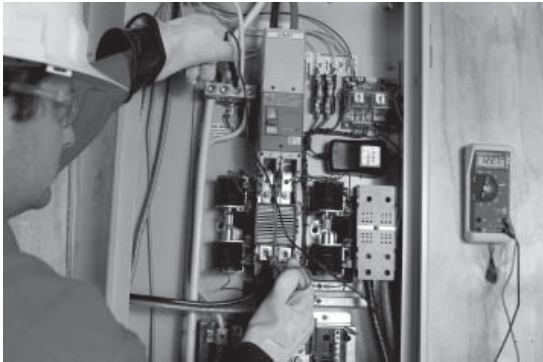

- Make sure there is no voltage on terminals E1 and E2 at the transfer switch contactor. If voltage is present, switch the main breaker OFF and check the terminations.



- Next, check the voltage to the load shedding switch.



- Check both line-to-line and line-to-neutral voltage on terminals E1 and E2. Terminations to T1 and T2 were made at the factory, but still make sure that voltage is correct at these terminals.



- Now check the terminations in the sub-panel. If there is a primary breaker in the sub-panel, make sure it is in the OFF position. Then check line-to-line and line-to-neutral voltage at the primary breaker.

VERIFYING LOAD SHEDDING OPERATION



- Switch the main breaker OFF. If there is a primary breaker in the sub-panel, make sure it is in the closed (ON) position.

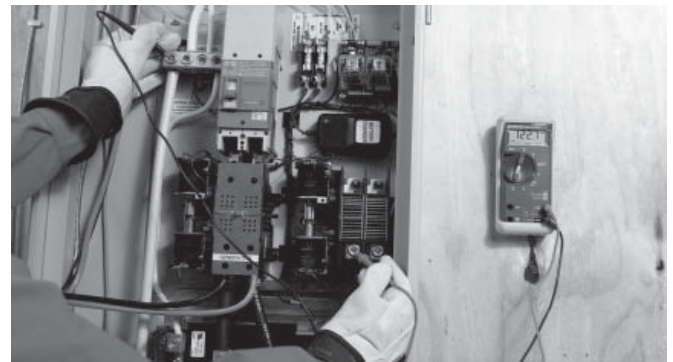

- Make sure the use the transfer switch contactor is still in the UP (UTILITY) position, and use the transfer handle to move the non-essential load shed contactor UP to the open (SHED) position. To move the non-essential load shed contactor UP to the open (SHED) position.



- With all branch circuit breakers still OFF, switch the main breaker ON. The load shed contactor should automatically move DOWN to the closed position, verifying that the load shedding switch is working properly.



- If not, switch OFF the main breaker, make sure all breakers and both contactors are in their correct positions and repeat the test.

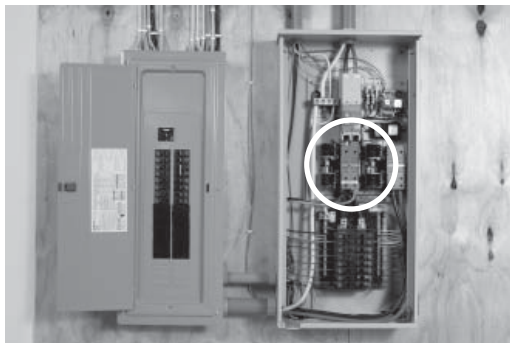

- Make sure that both the main breaker and the primary sub-panel breaker are closed (ON), all branch circuit breakers are open (OFF) and that the contactors for both the transfer switch and non-essential load shed switch are in the UTILITY position.



- With the generator's main breaker OFF, place the mode switch in MANUAL to start the engine.

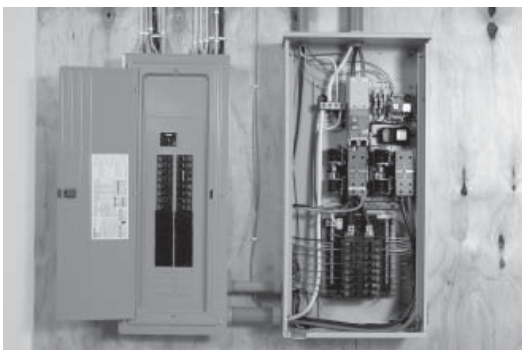

- For all models except the 8 and 10kW check to be sure that output voltage from the generator is correct. If line-to-line voltage is not approximately 240 volts, refer to the generator Owner's Manual for the proper adjustment procedure. On all models, if line-to-neutral voltage is not 120 volts, check the neutral connection between the generator and transfer switch. For 8 kW models check to be sure that the frequency from the generator is correct. If the frequency is not approximately 60Hz, refer to the generator Owner's Manual for the proper adjustment procedure.
- On all models, make sure line-to-line voltage on the control wires (N1 and N2) is correct.



- Using the mode switch, place the generator in AUTO. If utility power is still present, the generator will shut down.



- Switch the generator's main breaker ON. The generator is now ready for automatic operation.



- Shut OFF utility power at the transfer switch. The generator should start, and after a brief delay, the transfer contactor should move to the generator position.



- Switch the main breaker ON and make sure that power transfers back to the utility. The generator should shut down and go through a short cool-down cycle.

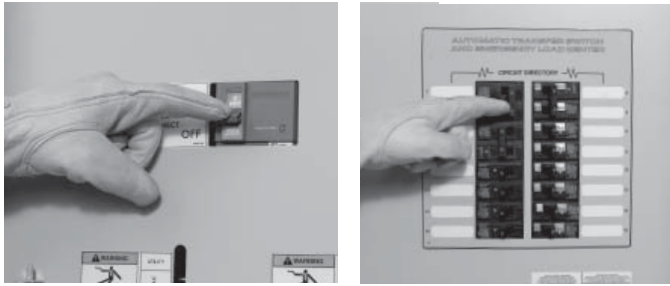

- Shut OFF utility power again to automatically start the generator. When power has transferred to the generator, close each of the breakers in the priority load center, one at a time, until the generator has accepted the entire priority load.
- Now close each of the breakers in the non-priority sub-panel one at a time until the generator has accepted the entire non-priority load. Be aware that should the generator become overloaded in the process, the Load Shed contactor will automatically move UP to the disconnect position, removing power from the non-priority loads. If this happens, it simply confirms that the load shedding switch is working properly. Close the remainder of the non-priority breakers.

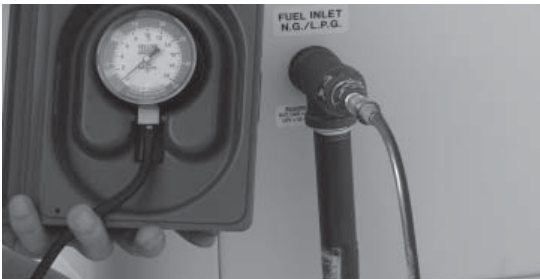

- With the generator carrying either the entire load (or the priority loads if the non-priority loads were shed) re-check gas pressure to the generator to verify that it's at the same level it was before the generator was started.



NOTE: Even if the generator is running smoothly at this point, a drop in gas pressure indicates that the supply is barely adequate to supply the generator's needs. Changes in the generator load, or additional gas demand by other appliances may affect the generator's performance. Verify gas pressure and pipe sizing. Unhook the manometer and reinstall the port plug.



- Switch the utility breaker ON to restore utility power to the home.



- The generator will continue to run to allow the engine to cool down before shutting itself OFF.



- Shut OFF utility power again. The generator should start and the entire load should transfer to the generator. If the load is too large, the non-essential load shed switch will automatically shed the non-priority loads.



- Close the main breaker to restore utility power and allow the engine to cool down and shut itself OFF. Operational tests are now complete. Refer to Appendix F – Setting the Automatic Exercise Function to complete the installation.

APPENDIX E – GENREADY LOAD CENTER INSTALLATION AND OPERATIONAL TESTING



1. Before beginning any installation, make sure power is shut OFF and carefully read the Owner's Manual that came with the load center.
When choosing a location for the load center, make sure no water or corrosive substances can drip onto the enclosure.
2. Always inspect the load center for shipping damage. Never mount a load center that shows any evidence of damage.



3. Check local codes before wiring the load center. Some jurisdictions require that wiring inside the load center be done by a licensed electrician.

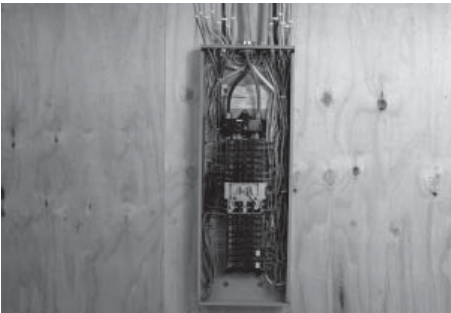

4. Protect against impact and mount the load center vertically to a rigid support structure. Make sure the load center is level and plumb.



5. All wiring must be the correct size and type, and must conform to all codes, standards and regulations. Refer to the load center Owner's Manual and the National Electrical Code (NEC) for additional information. As with any product, design changes can occur over time, so always refer to the schematics in the load center Owner's Manual for the required connections and safety precautions.

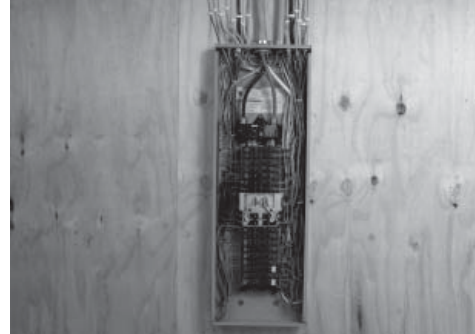

6. The load center being used contains, or will contain, an open transition operator. Open transition prevents electrical feedback between the generator and the utility by only allowing load circuits to be connected to one power supply at a time.



7. If the load center will serve as the service entrance for the house, install the ground to neutral bond. Refer to the National Electrical Code (NEC) for complete information on grounding and bonding.

BATTERY CHARGER INSTALLATION



1. The generator battery charger is to be installed in the generator when using a GenReady load center. Refer to the Battery Charger Installation Guide for details.

ELECTRICAL CONNECTIONS

1. Connect the utility power leads from the meter to the main Utility circuit breaker in the load center.

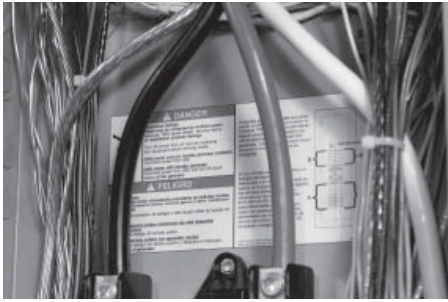

During installation, be careful to torque the lugs on all circuit breakers to the specifications listed in the load center Owner's Manual.

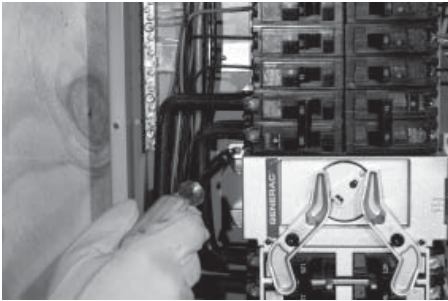

2. If the load center is being installed with a generator, locate and install the load center operator. Refer to the installation instructions packed with the operator for installation details.

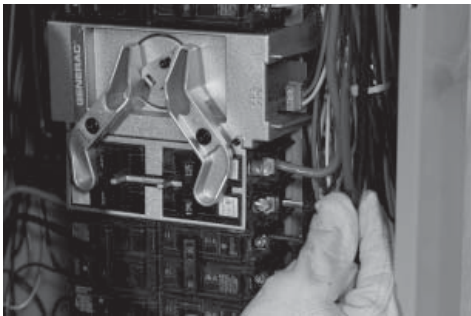

3. Connect the generator power leads to the generator feed breaker. This is the 2 pole breaker directly below the operator on the right side of the load center.



4. Connect the neutral wire from the utility and generator to the neutral bar on the right side of the load center panel and the generator equipment ground wire to the ground bar on the left side of the load center panel.

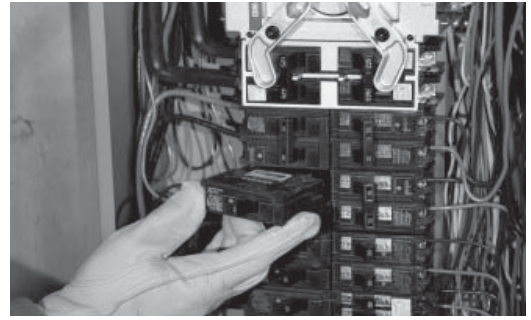

5. Connect the customer loads to the load center. The breakers above the operator are used for loads which will not be backed up during a power outage. Connect these loads to the appropriate sized breakers in the load center. When selecting circuits, note that the breakers immediately above and below the operator are dedicated for use by the generator and load center, and may not be used for customer loads.



6. Next, connect the loads which are to be backed up. The breakers below the operator will be backed up by the generator during a power outage. Connect these loads to the appropriate sized breakers in the load center.



7. If the generator is not being installed at this time, loads can still be connected to the lower breakers. Simply make sure the utility feed breaker, the 2 pole breaker directly below the operator on the left side of the load center, is switched ON.

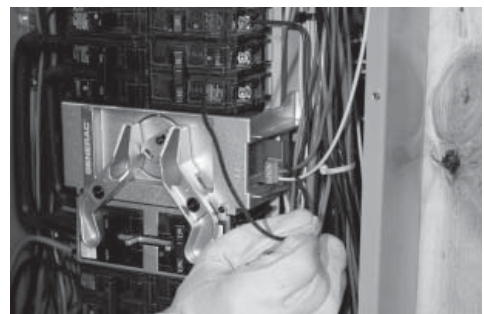

- Connect the control wires from the generator to the load center operator. Connect the 23 wire to the XFER terminal, 15B to the BAT+ terminal, and 0 to the BAT-terminal.

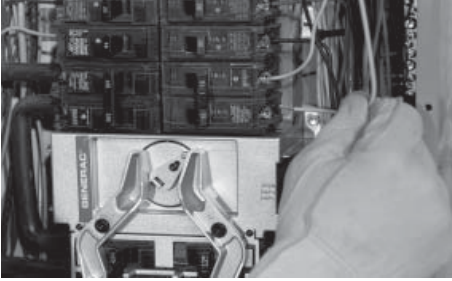

- Connect the voltage sensing wires to the sense breaker. This is the 2 pole breaker directly above the operator on the right side of the load center. Connect N1 to one pole of the breaker, and N2 to the other.



- Switch ON the main utility breaker if not already on and switch on the utility supply breaker for the priority circuits. Make sure utility voltage at the load center is correct. Refer to NFPA 70E for the safety equipment required when working inside a live load center.

OPERATIONAL TESTING

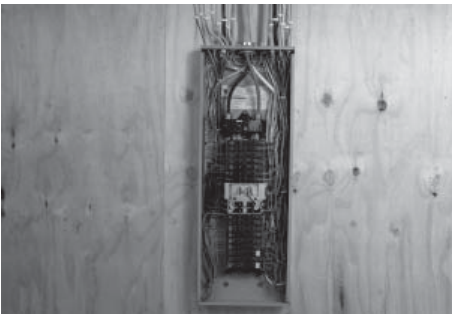

- The following operational tests are meant to be performed with a fully installed system. If the GenReady panel was installed without a generator, these tests cannot be performed.



- Switch the generator's main circuit breaker OFF and put the mode switch in the OFF position.



- Switch the main utility breaker OFF and place all of the individual protected branch circuit breakers (located below the transfer operator) in the OFF position.



- Manually switch the generator circuit breaker (just below the transfer operator) to the ON position. This will also move the utility feed circuit breaker to the OFF position. **NEVER MOVE THE LOAD CENTER FEED BREAKERS MANUALLY WHEN LOADS ARE CONNECTED.**



- With the generator's main breaker OFF, put the mode switch in MANUAL to start the engine.



- Allow the engine to warm up, then switch the generator's main breaker to the ON position. The generator is now supplying electricity to the lower half of the load center but is not carrying any load.



- For all models except the 8 and 10 kW check to be sure that voltage from the generator is correct. If line-to-line voltage is not approximately 240 volts, refer to the generator Owner's Manual for the proper adjustment procedure. On all models, if line-to-neutral voltage is not 120 volts, check the neutral connection between the generator and load center.

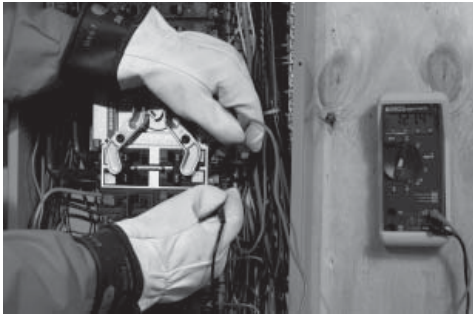

- For 8 kW models check to be sure that the frequency from the generator is correct. If the frequency is not approximately 60Hz, refer to the generator Owner's Manual for the proper adjustment procedure.



- Switch the generator's main circuit breaker OFF and put the mode switch in the OFF position to shut down the generator.



- With utility power still OFF, switch the utility feed breaker (below the transfer operator on the left side of the load center) ON. This will also move the generator feed breaker to the OFF position.

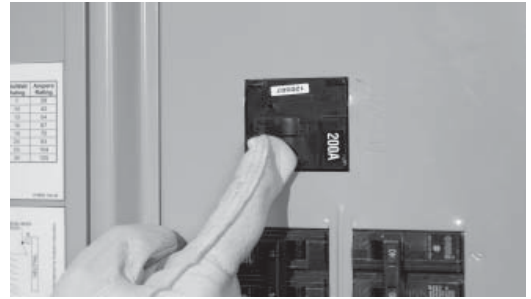

- Switch the main utility breaker ON to restore utility power.



- Switch the generator's main breaker ON and put the mode switch in AUTO.



- Shut OFF utility power at the main utility breaker and make sure the generator starts automatically.

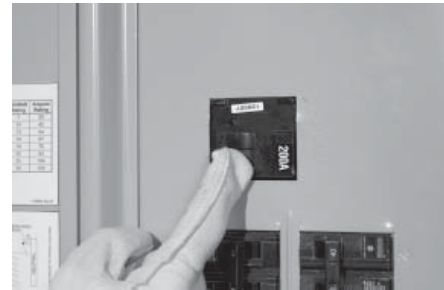

- Switch the main utility breaker to ON and make sure that power on the lower half on the load center is automatically transferred back to the utility. This can be verified by noting the position of the utility feed and generator feed breakers.



- Shut OFF utility power again to automatically start the generator. When power on the lower half of the load center has transferred to the generator, turn ON each of the branch circuit breakers in the lower half of the load center, one at a time, until the generator has accepted the entire priority load.



- With the generator carrying the entire priority load, re-check gas pressure to verify that it's at the same level it was before the generator was started.

NOTE: Even if the generator is running smoothly at this point, a drop in gas pressure indicates that the supply is barely adequate to supply the generator's needs. Changes in the generator load, or additional gas demand by other appliances may affect the generator's performance. Verify gas pressure and pipe sizing. Unhook the manometer and reinstall the port plug.

APPENDIX F - SETTING THE AUTOMATIC EXERCISE FUNCTION



- To set the exercise on 8 kW models, make sure with the mode switch is in AUTO. Press and hold down the EXERCISER switch for at least 10 seconds and release. The generator should start within a few seconds. The unit will run for about 12 minutes before shutting itself down automatically. If the battery is ever disconnected or the fused is removed for any reason, the exercise function will have to be reset.



- On all other models, the display will enter an Installation Assistant mode when battery power is first connected. The assistant will prompt to first enter the current date and time, followed by the exercise day and time. If the battery is ever disconnected and reconnected, or fuse removed and replaced, the Installation Assistant will be displayed again, but only the current date and time will need to be entered.



- If the exercise time or day ever needs to be changed, press the escape key to access the main menu.



- Press the left or right arrow key until 'Edit' is flashing and press enter.



- Press the right or left arrow key until the exercise time is displayed and press enter.



- Using the arrow and enter keys first set the exercise hour in 24 hour format, followed by the minute, and finally the day.



7. Once set, the generator will exercise each week at the same time. Be sure to show the owners how to set the exercise function for the day and time they want the unit to exercise.



8. If the generator is equipped with the low speed exercise feature, it was enabled at the factory and no adjustment is needed.

Every installation has its own unique set of circumstances and requirements. This booklet provides guidelines for basic installations only and is not intended to cover all applications. If there are any questions or concerns after carefully reading all documentation received with the equipment, contact the nearest dealer for assistance.

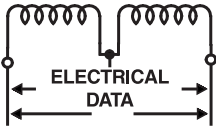

Electrical Data

Wiring Diagram - 8kW - Drawing No. 0G7945-A

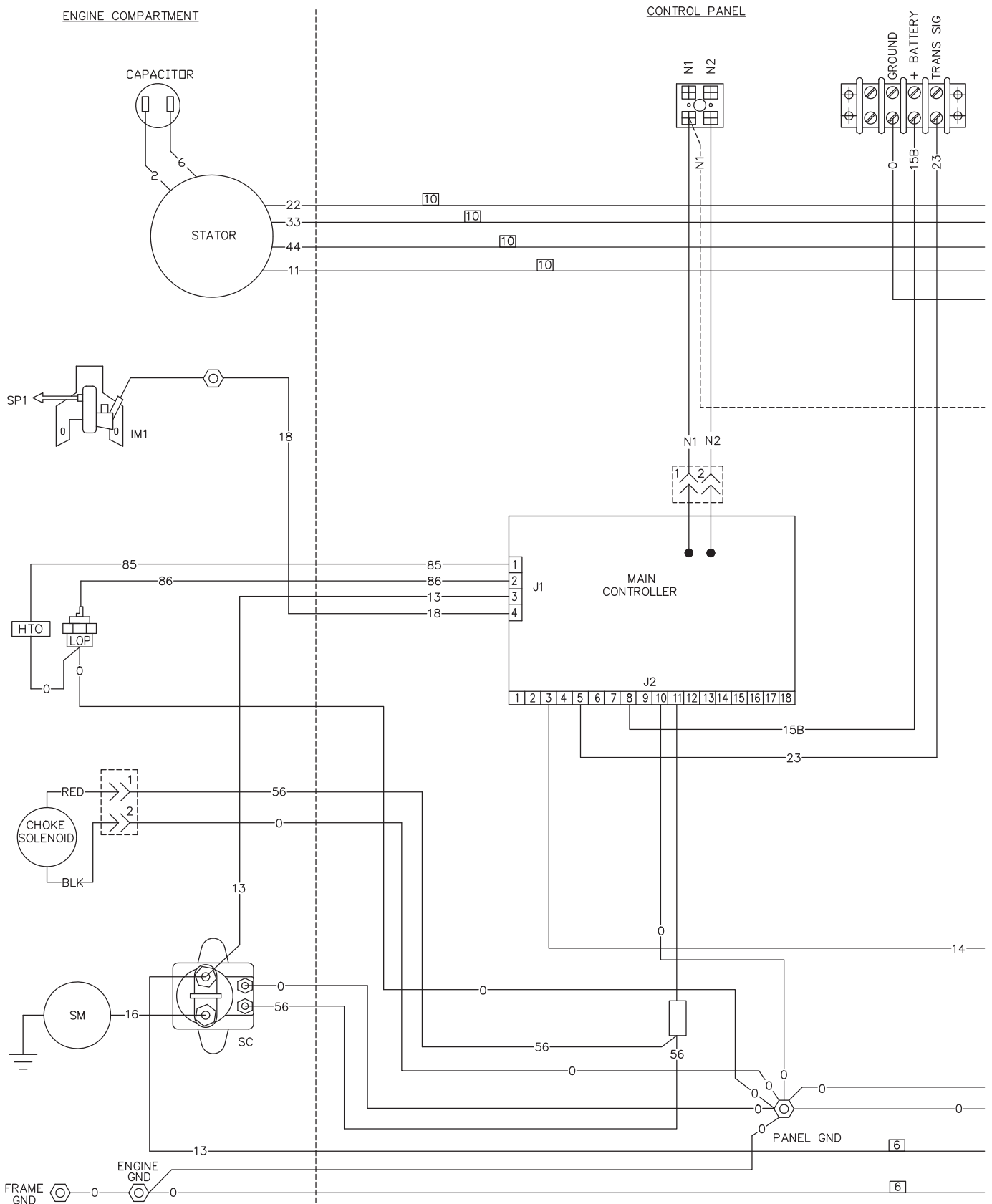

Electrical Data
Wiring Diagram - 8kW - Drawing No. 0G7945-A

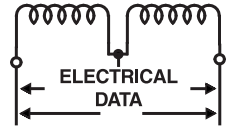

CUSTOMER CONNECT AREA

240V GENERATOR
 OUTPUT TO TRANSFER
 SWITCH CONTACTOR

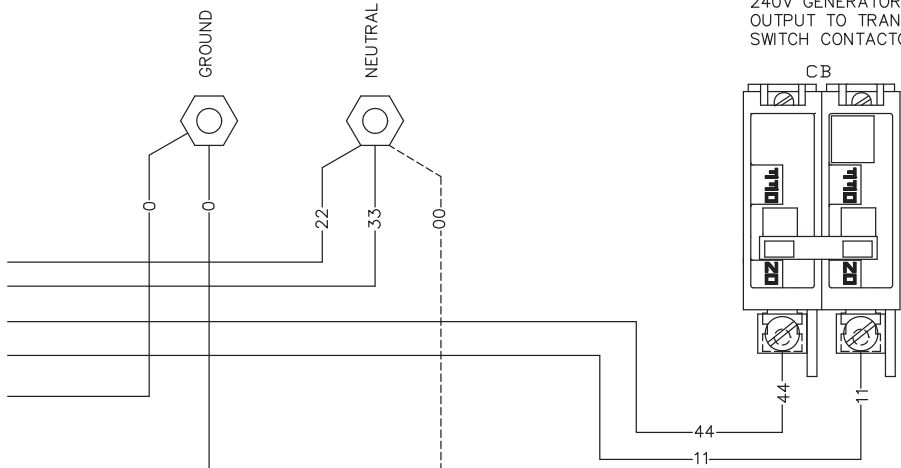

LEGEND

- CB - CIRCUIT BREAKER, MAIN OUTPUT
- GND - GROUND
- HTO - HIGH TEMPERATURE SWITCH
- IM1 - IGNITION MODULE
- LOP - LOW OIL PRESSURE SWITCH
- SC - STARTER CONTACTOR
- SM - STARTER MOTOR
- SP1 - SPARK PLUG
- - SPLICE

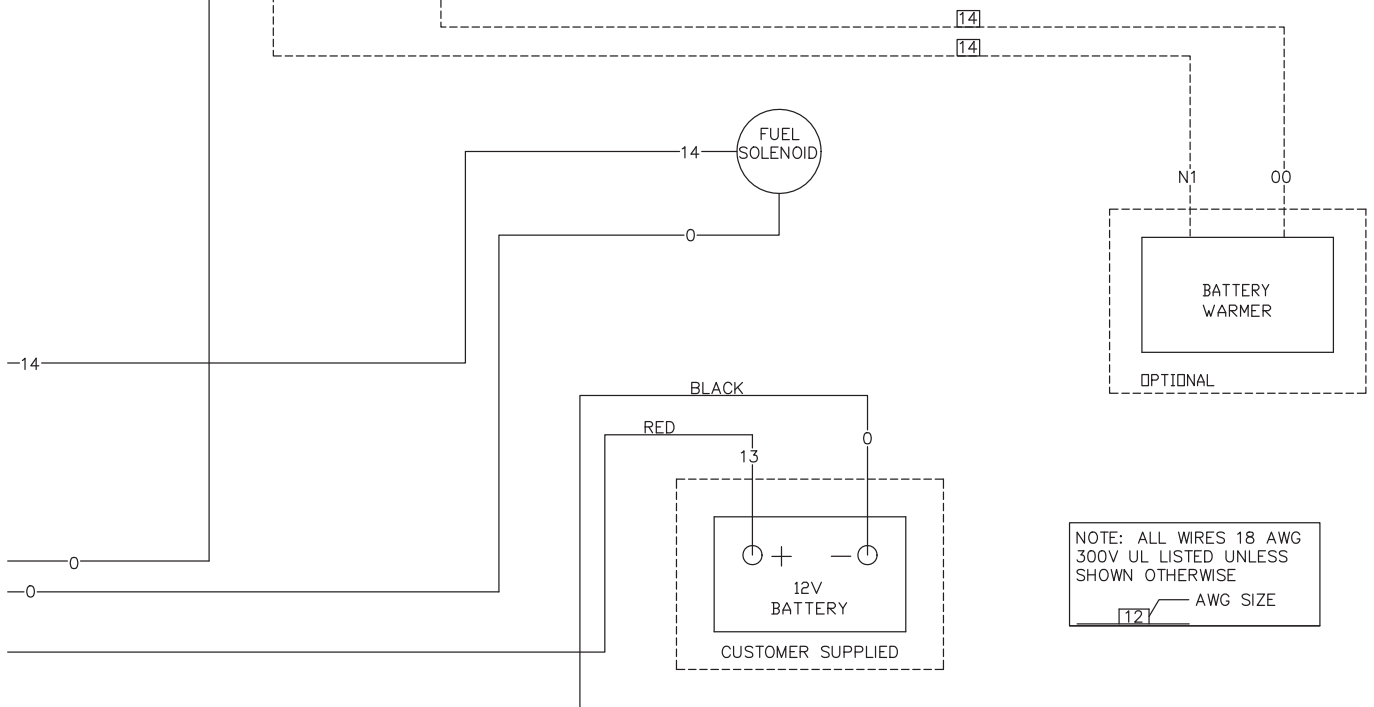

NOTE: ALL WIRES 18 AWG
 300V UL LISTED UNLESS
 SHOWN OTHERWISE
 12 AWG SIZE

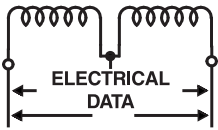

Electrical Data

Electrical Schematic - 8kW – Drawing No. 0G8511-A

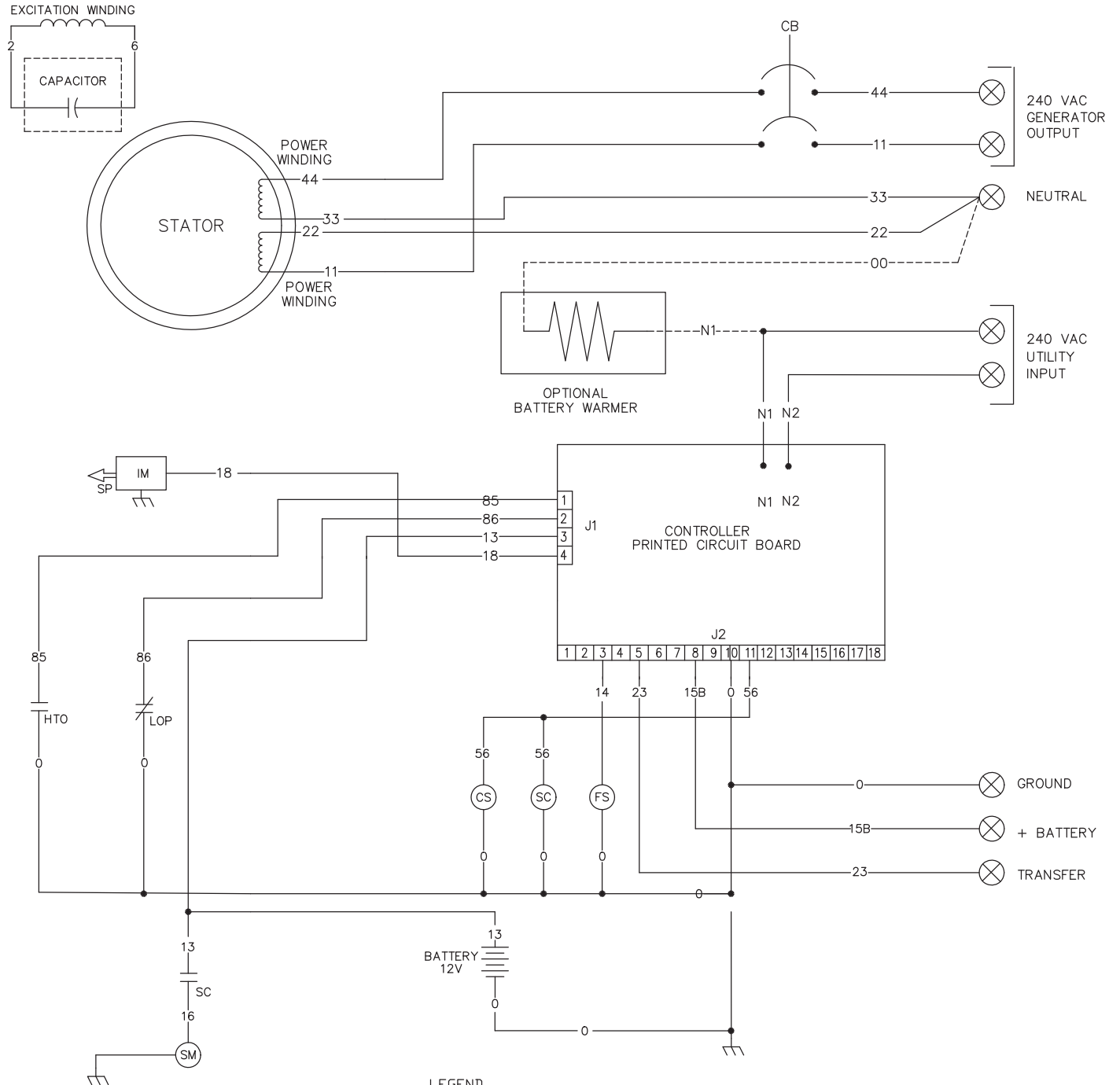

LEGEND

- | | |
|-----------------------------------|-------------------------------|
| CB - CIRCUIT BREAKER, MAIN OUTPUT | LOP - LOW OIL PRESSURE SWITCH |
| CS - CHOKE SOLENOID | SC - STARTER CONTACTOR |
| FS - FUEL SOLENOID | SM - STARTER MOTOR |
| HTO - HIGH TEMPERATURE SWITCH | SP - SPARK PLUG |
| IM - IGNITION MODULE | |

Electrical Data
Electrical Schematic - 10kW – Drawing No. 0G8512-A

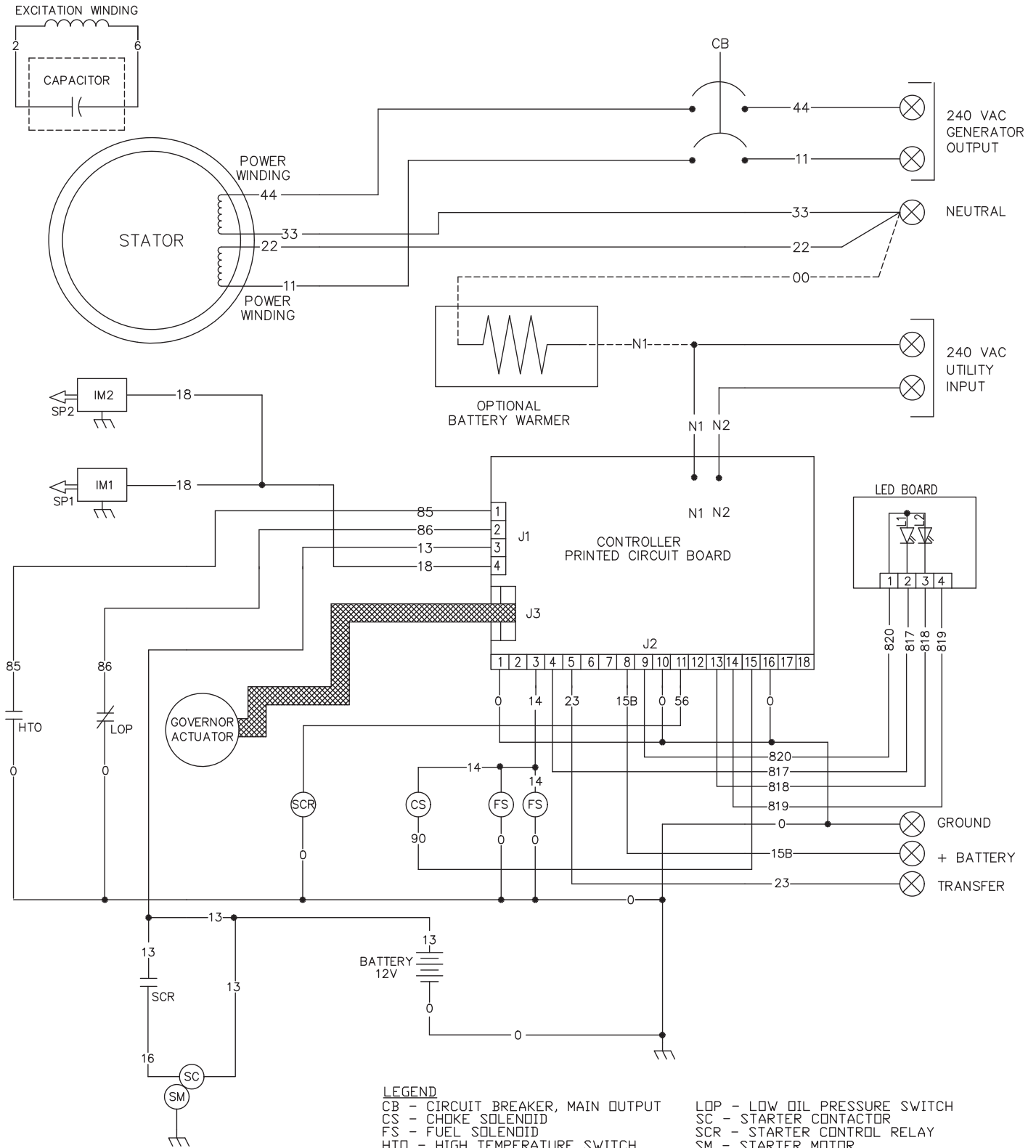
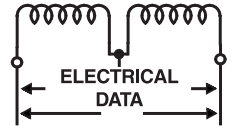

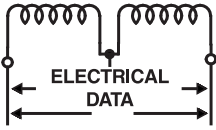

Electrical Data

Wiring Diagram - 10kW - Drawing No. 0G7946-A

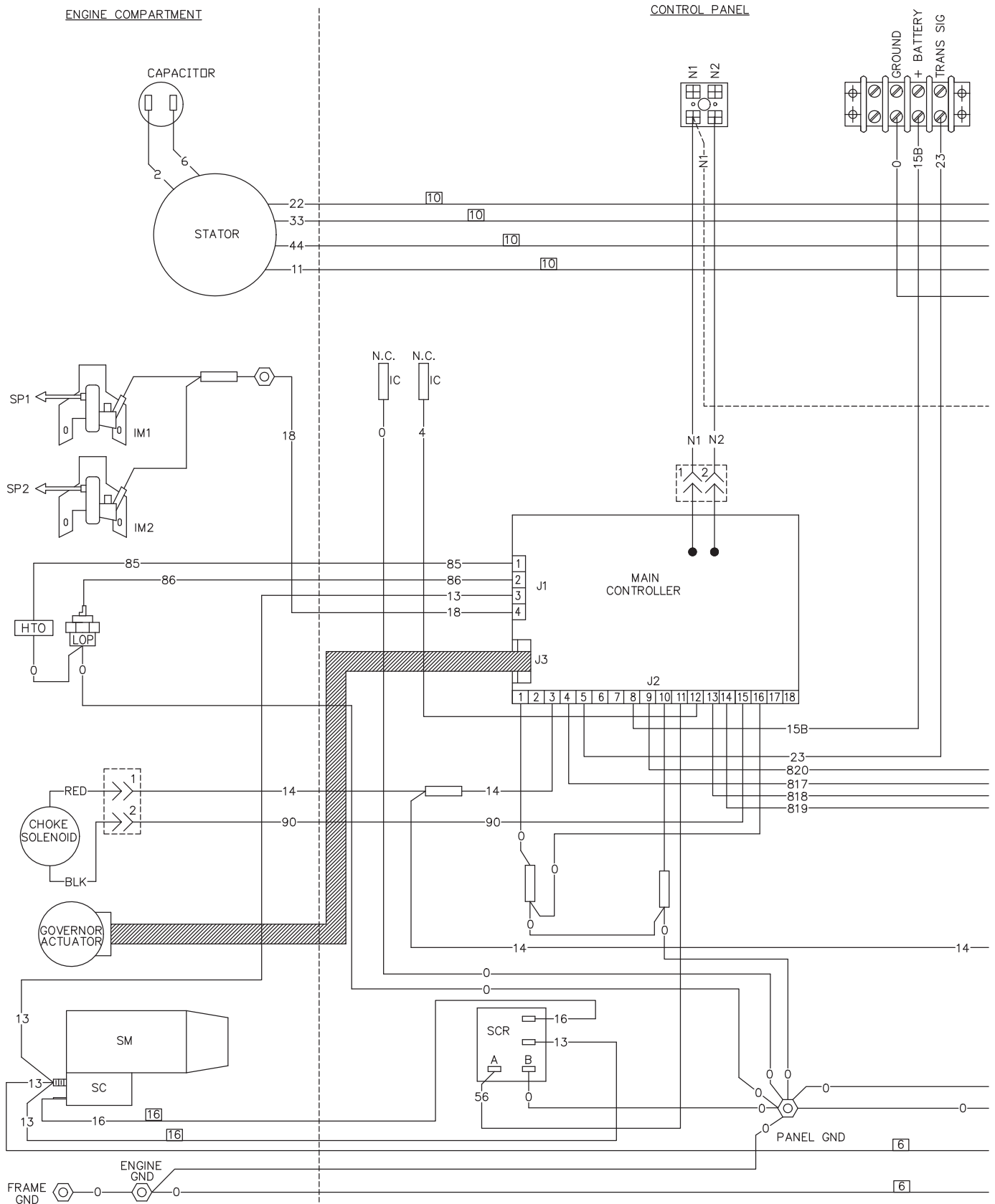

Electrical Data

Wiring Diagram - 10kW – Drawing No. 0G7946-A

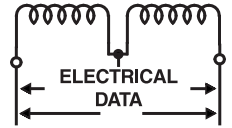

CUSTOMER CONNECT AREA

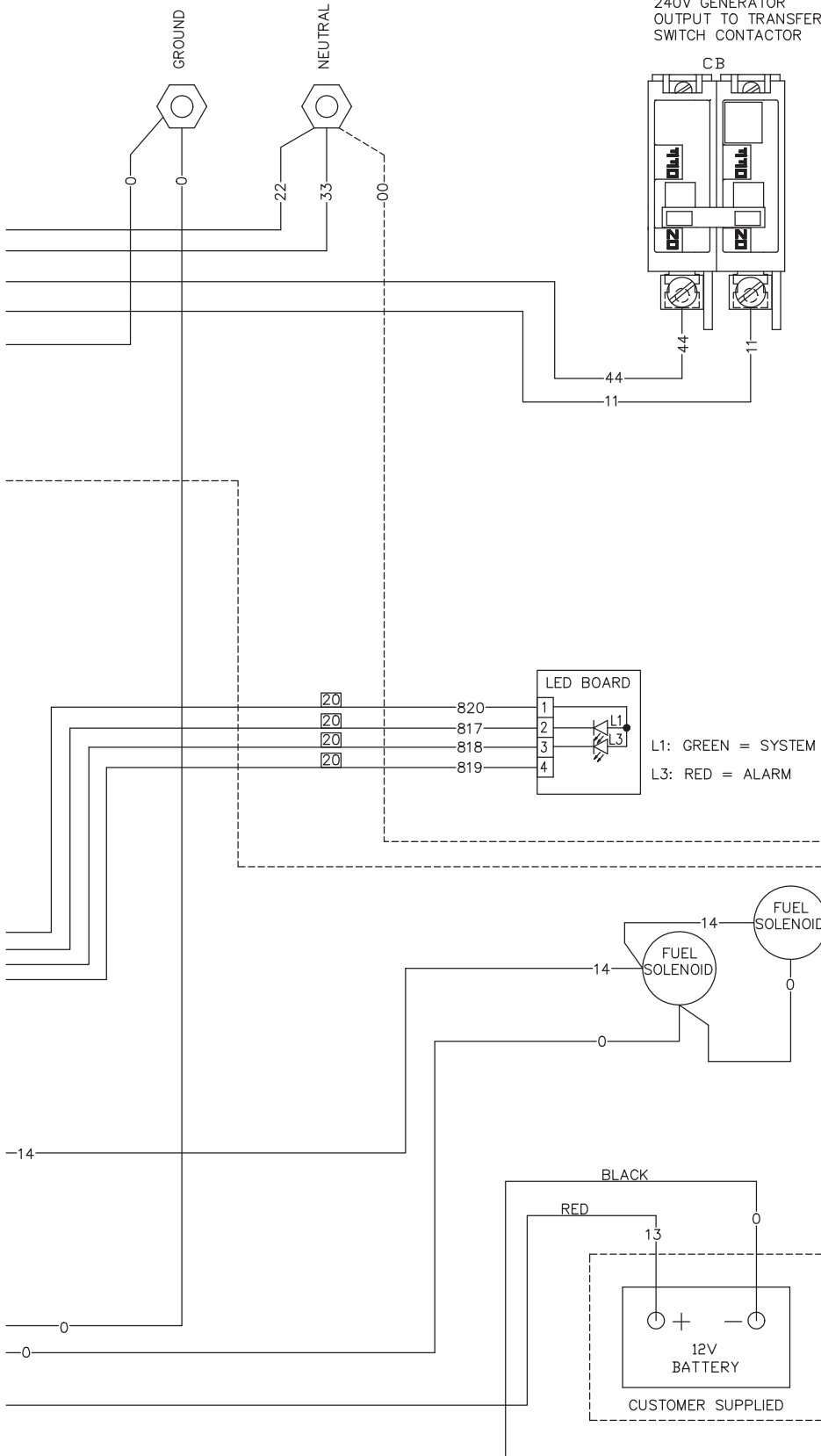

LEGEND

- CB - CIRCUIT BREAKER, MAIN OUTPUT
- GND - GROUND
- HTO - HIGH TEMPERATURE SWITCH
- IM_ - IGNITON MODULE
- LOP - LOW OIL PRESSURE SWITCH
- SC - STARTER CONTACTOR
- SCR - STARTER CONTROL RELAY
- SM - STARTER MOTOR
- SP_ - SPARK PLUG
- [Symbol] - SPLICE
- [Symbol] - DISCONNECT SPLICE
- IC

L1: GREEN = SYSTEM READY
L3: RED = ALARM

NOTE: ALL WIRES 18 AWG
300V UL LISTED UNLESS
SHOWN OTHERWISE
[Symbol] AWG SIZE

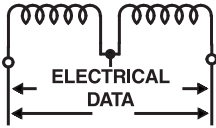

Electrical Data

Wiring Diagram - 12 & 14kW – Drawing No. 0G7947-A

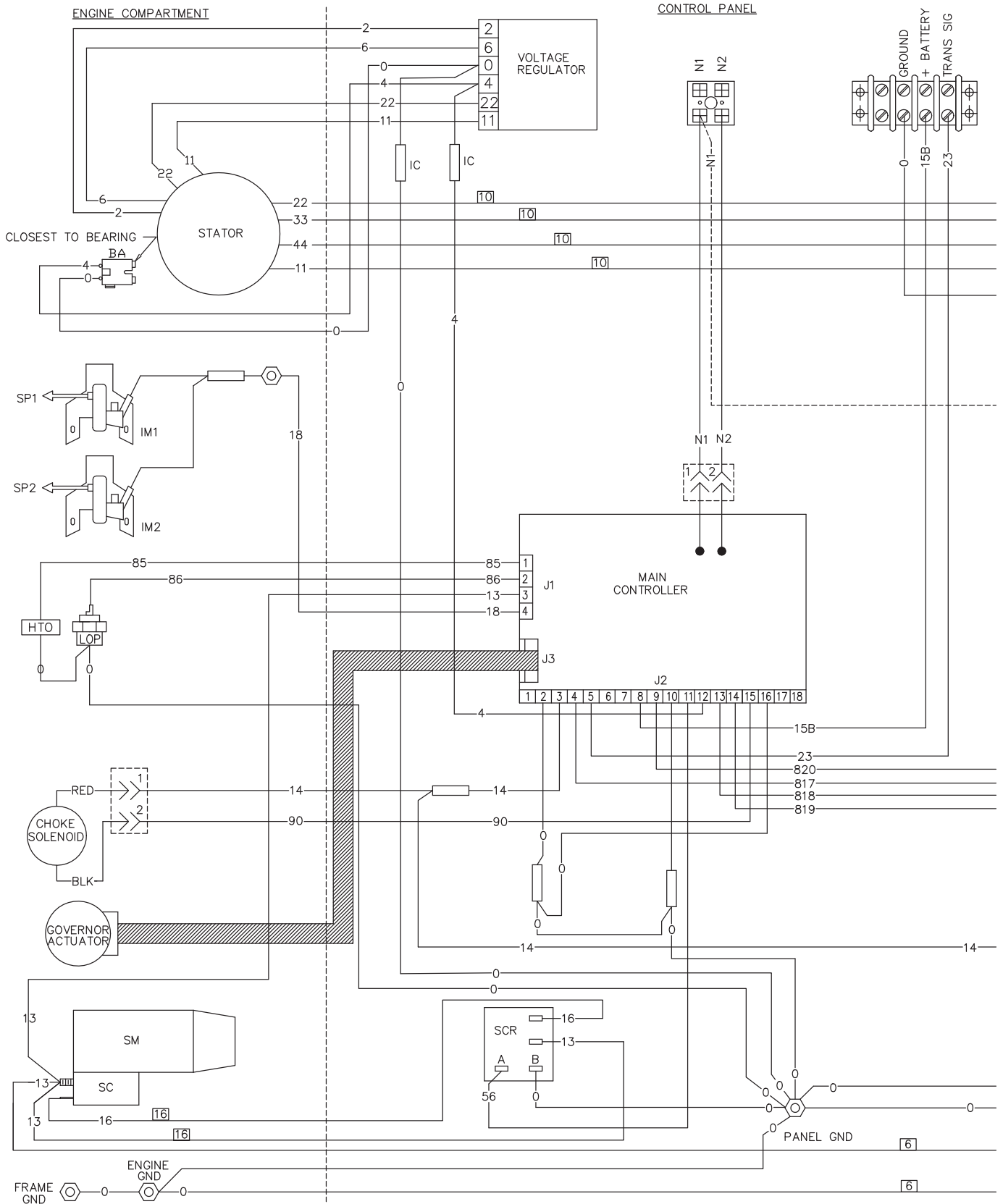

Electrical Data

Wiring Diagram - 12 & 14kW – Drawing No. 0G7947-A

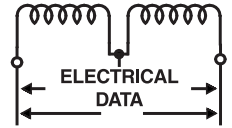

CUSTOMER CONNECT AREA

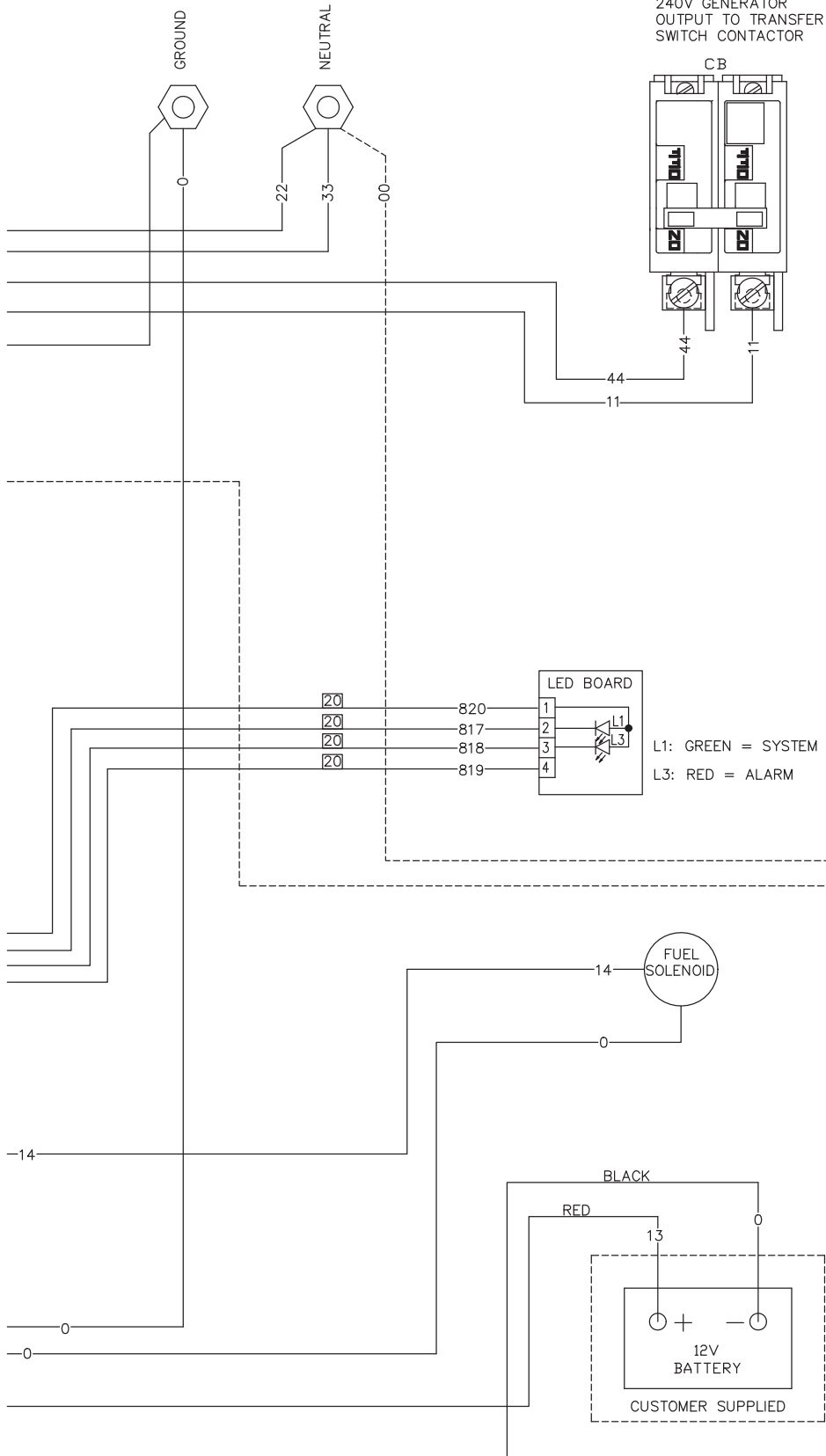

240V GENERATOR
OUTPUT TO TRANSFER
SWITCH CONTACTOR

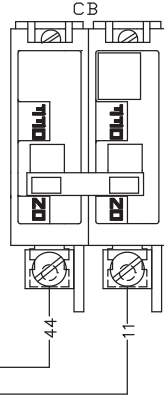

LEGEND

- BA - BRUSH ASSEMBLY
- CB - CIRCUIT BREAKER, MAIN OUTPUT
- GND - GROUND
- HTO - HIGH TEMPERATURE SWITCH
- IM_ - IGNITION MODULE
- LOP - LOW OIL PRESSURE SWITCH
- SC - STARTER CONTACTOR
- SCR - STARTER CONTROL RELAY
- SM - STARTER MOTOR
- SP_ - SPARK PLUG
- [Symbol] - SPLICE
- [Symbol] - DISCONNECT SPLICE
- IC

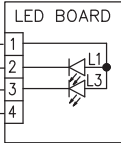

L1: GREEN = SYSTEM READY
L3: RED = ALARM

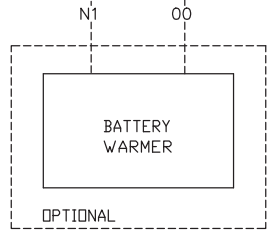

NOTE: ALL WIRES 18 AWG
300V UL LISTED UNLESS
SHOWN OTHERWISE
[Symbol] AWG SIZE

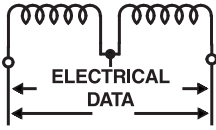

Electrical Data

Electrical Schematic - 12 & 14kW – Drawing No. 0G8513-A

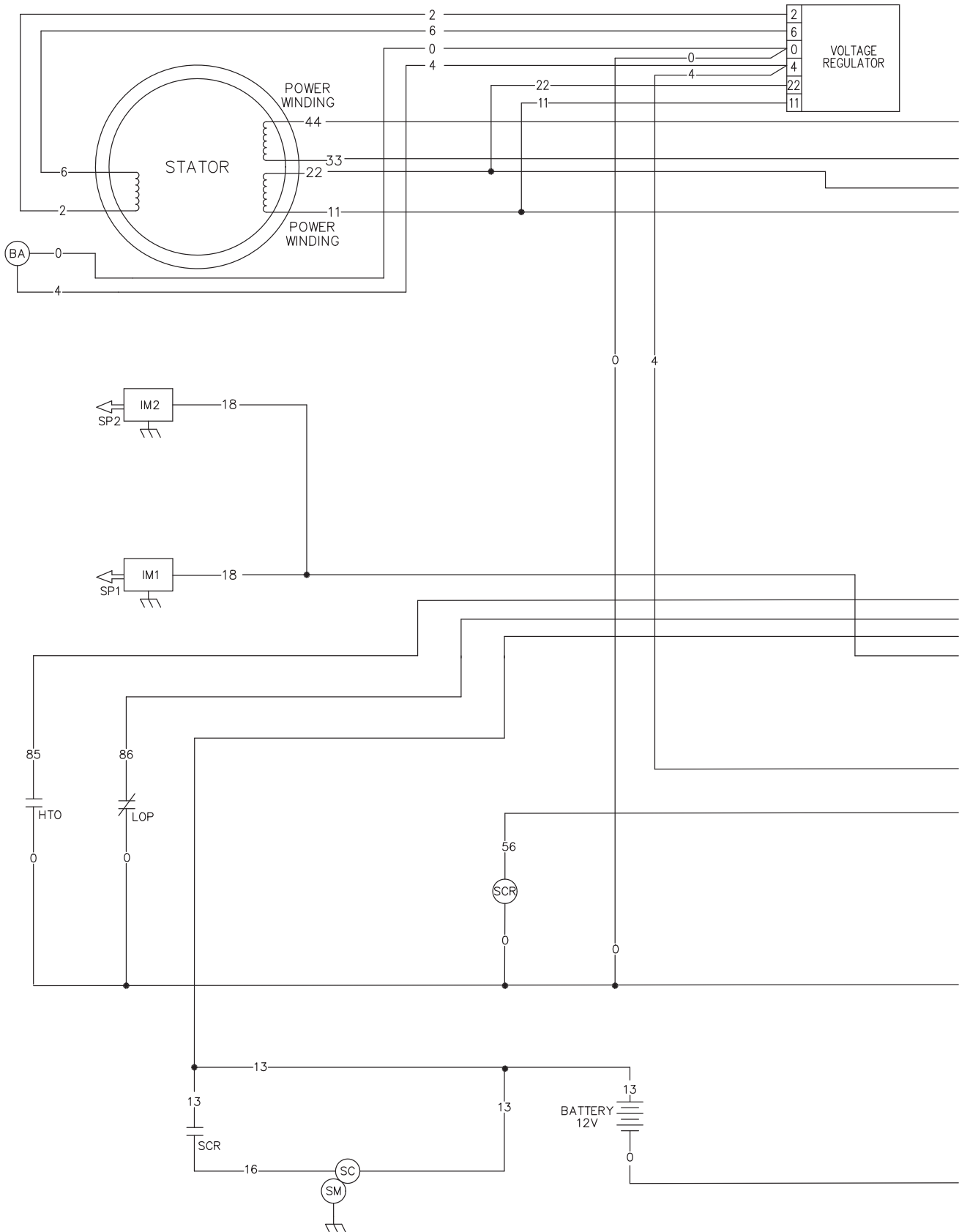

Electrical Data

Electrical Schematic - 12 & 14kW – Drawing No. 0G8513-A

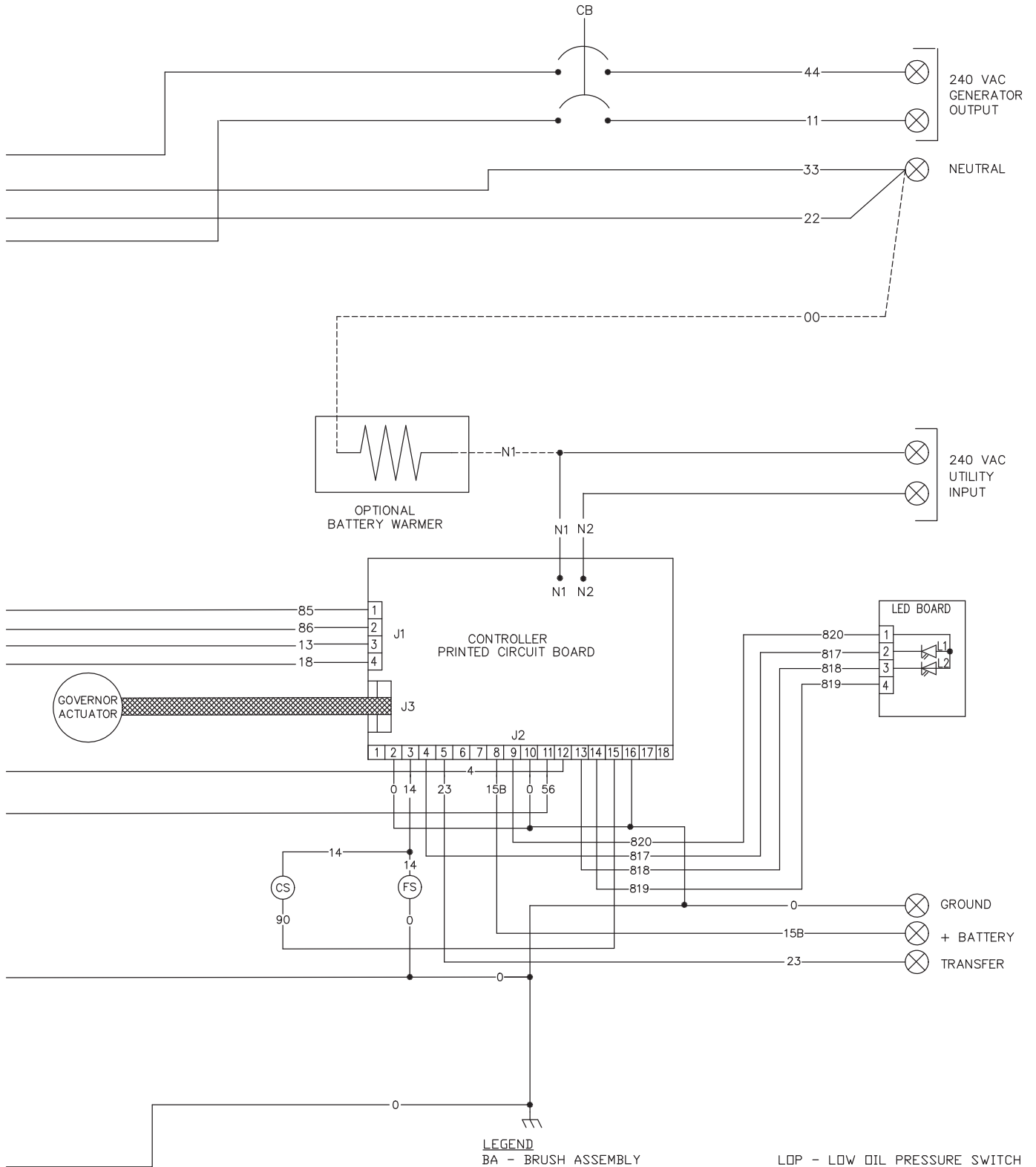
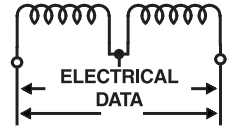

- LEGEND**
- BA - BRUSH ASSEMBLY
 - CB - CIRCUIT BREAKER, MAIN OUTPUT
 - CS - CHOKE SOLENOID
 - FS - FUEL SOLENOID
 - HTD - HIGH TEMPERATURE SWITCH
 - IM_ - IGNITION MODULE
 - LDP - LOW OIL PRESSURE SWITCH
 - SC - STARTER CONTACTOR
 - SCR - STARTER CONTROL RELAY
 - SM - STARTER MOTOR
 - SP_ - SPARK PLUG

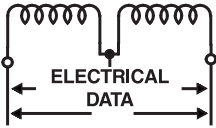

Electrical Data

Wiring Diagram - 16 & 17kW – Drawing No. 0G7948-A

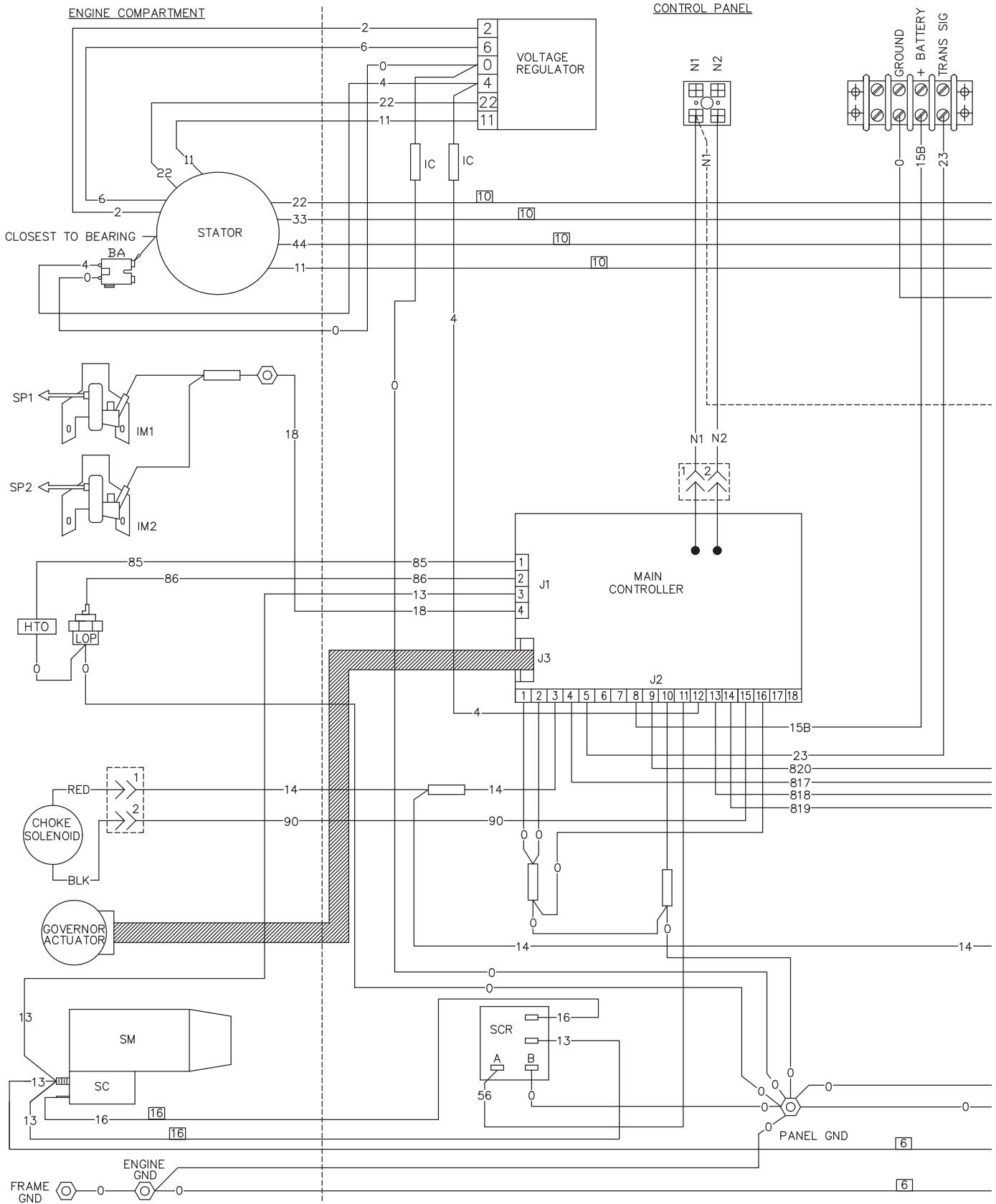

Electrical Data
Wiring Diagram - 16 & 17kW – Drawing No. 0G7948-A

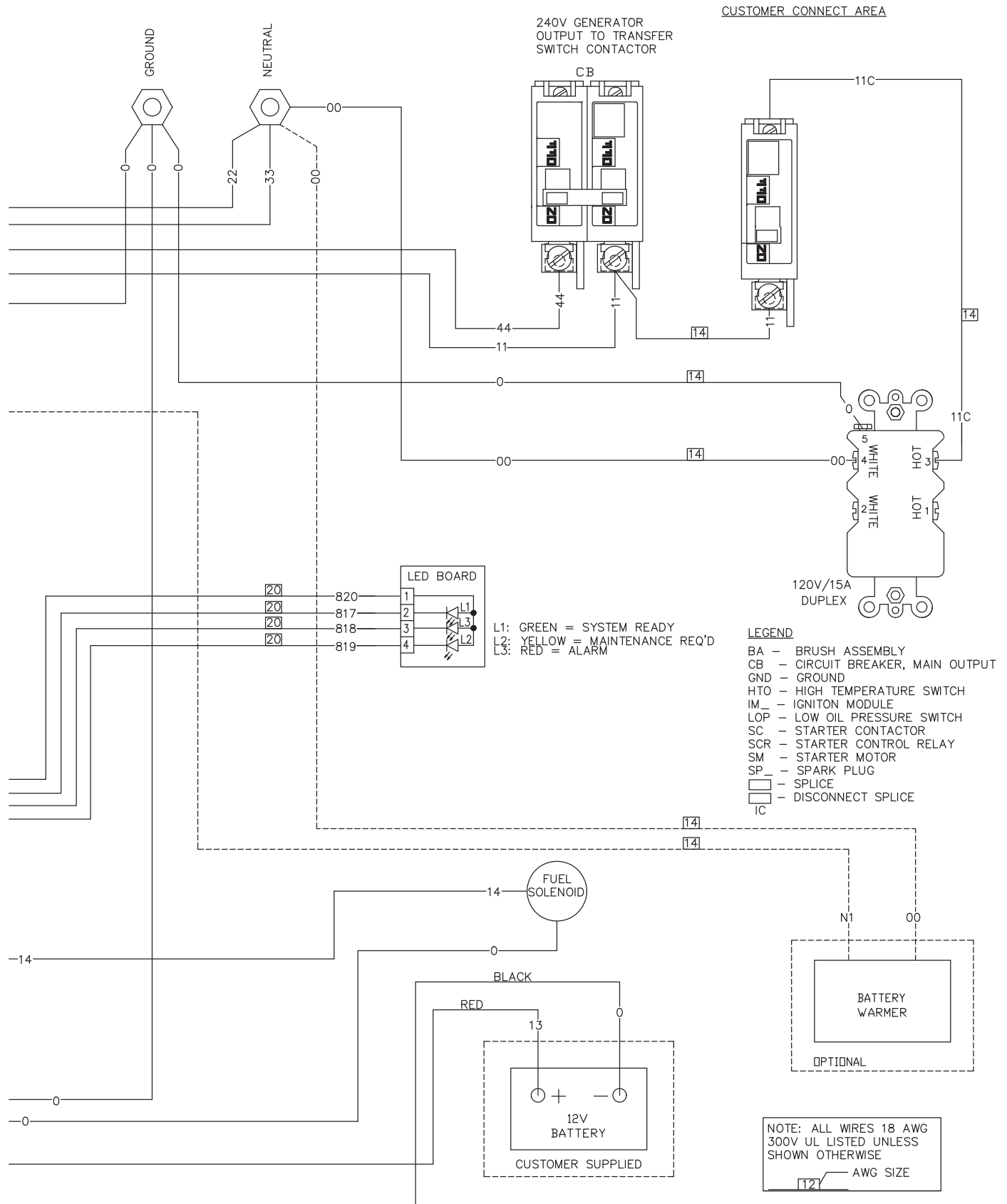
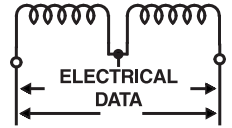

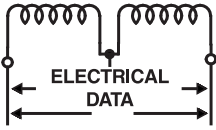

Electrical Data

Electrical Schematic - 16 & 17kW - Drawing No. 0G8514-A

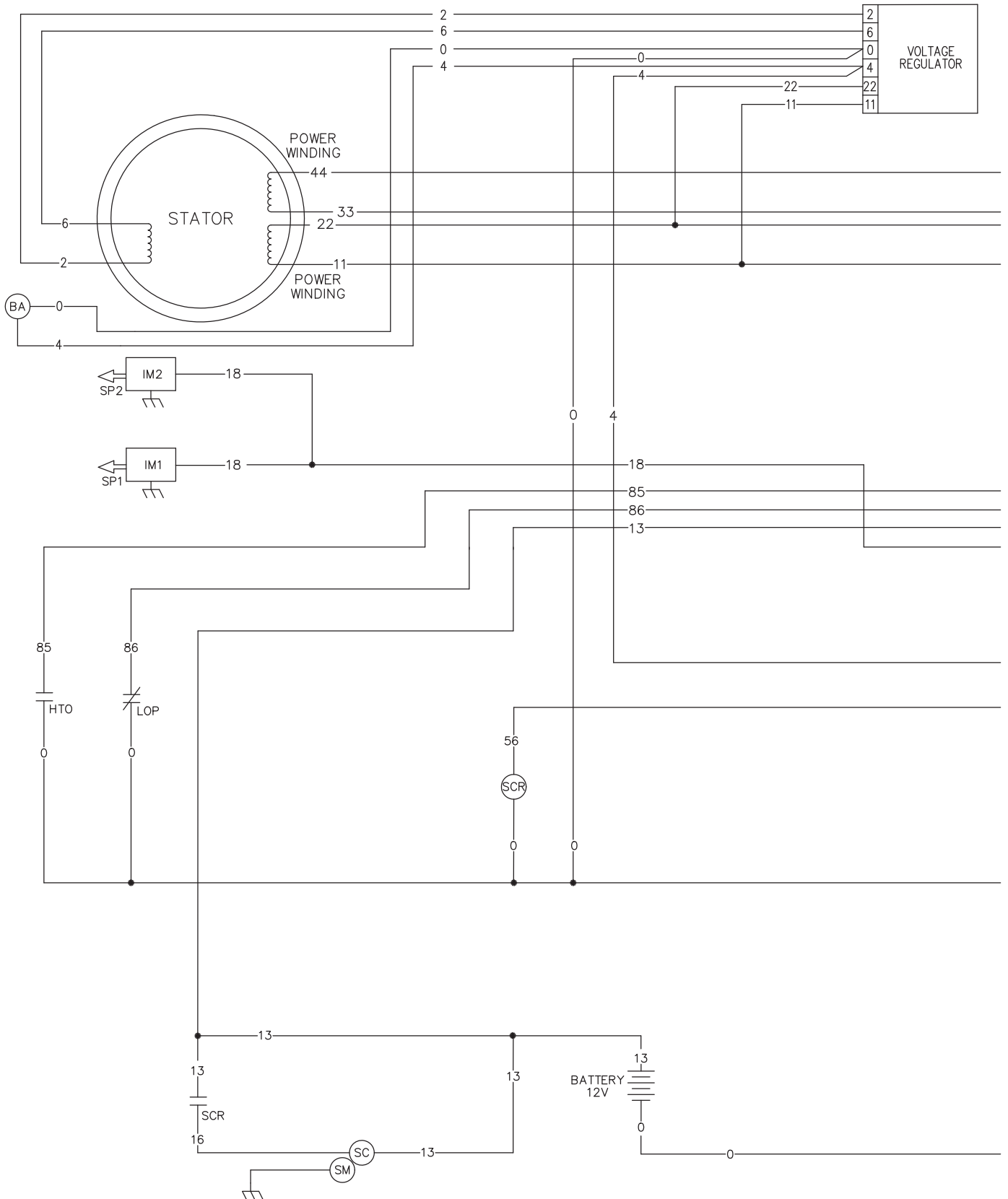

Electrical Data
Electrical Schematic - 16 & 17kW – Drawing No. 0G8514-A

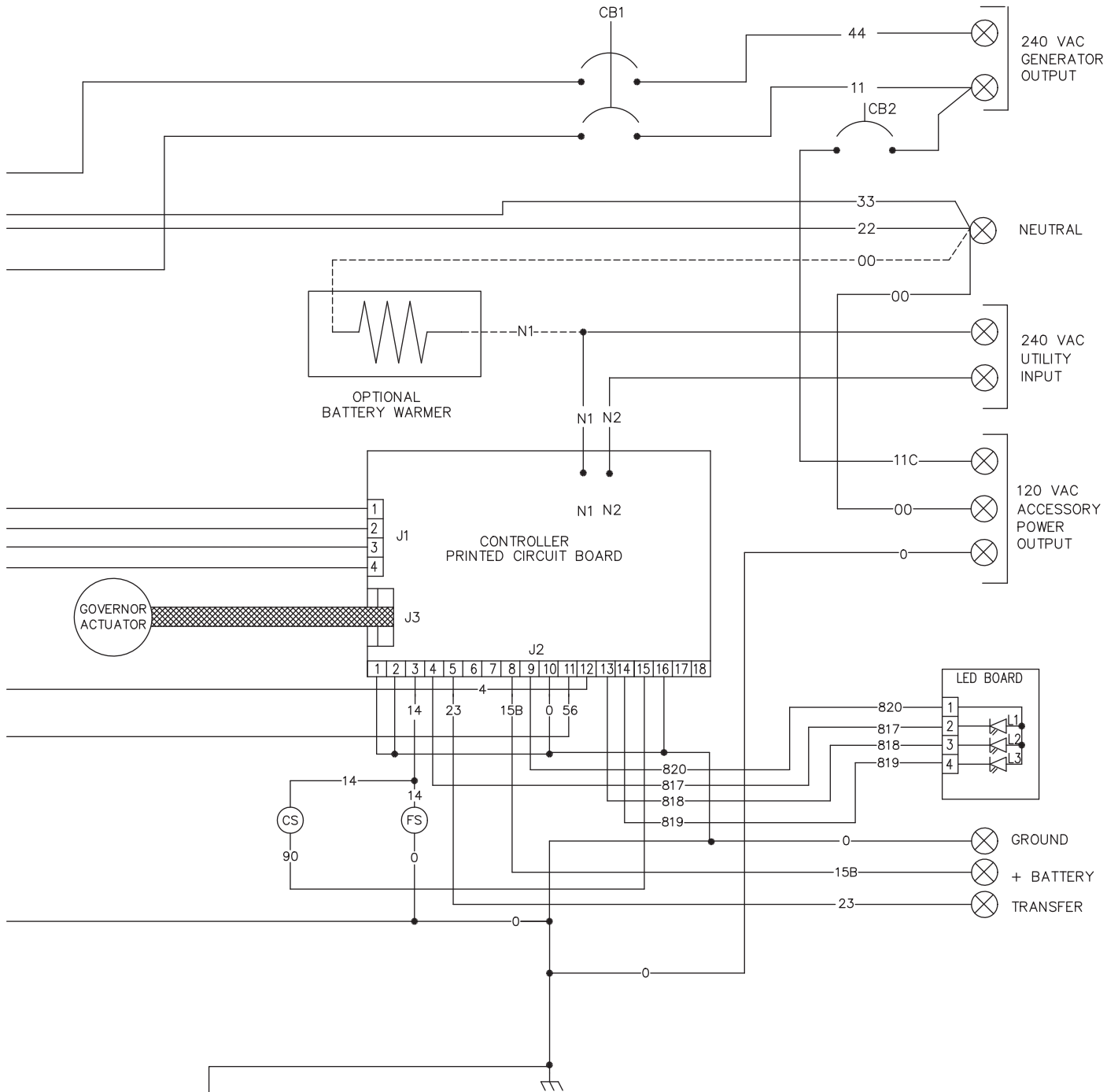
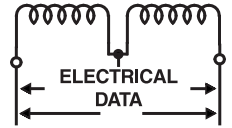

LEGEND

BA - BRUSH ASSEMBLY
 CB - CIRCUIT BREAKER, MAIN OUTPUT
 CS - CHOKE SOLENOID
 FS - FUEL SOLENOID
 HTO - HIGH TEMPERATURE SWITCH
 IM - IGNITION MODULE

LDP - LOW OIL PRESSURE SWITCH
 SC - STARTER CONTACTOR
 SCR - STARTER CONTROL RELAY
 SM - STARTER MOTOR
 SP - SPARK PLUG

Electrical Data
Wiring Diagram - 20kW – Drawing No. 0G8186-A

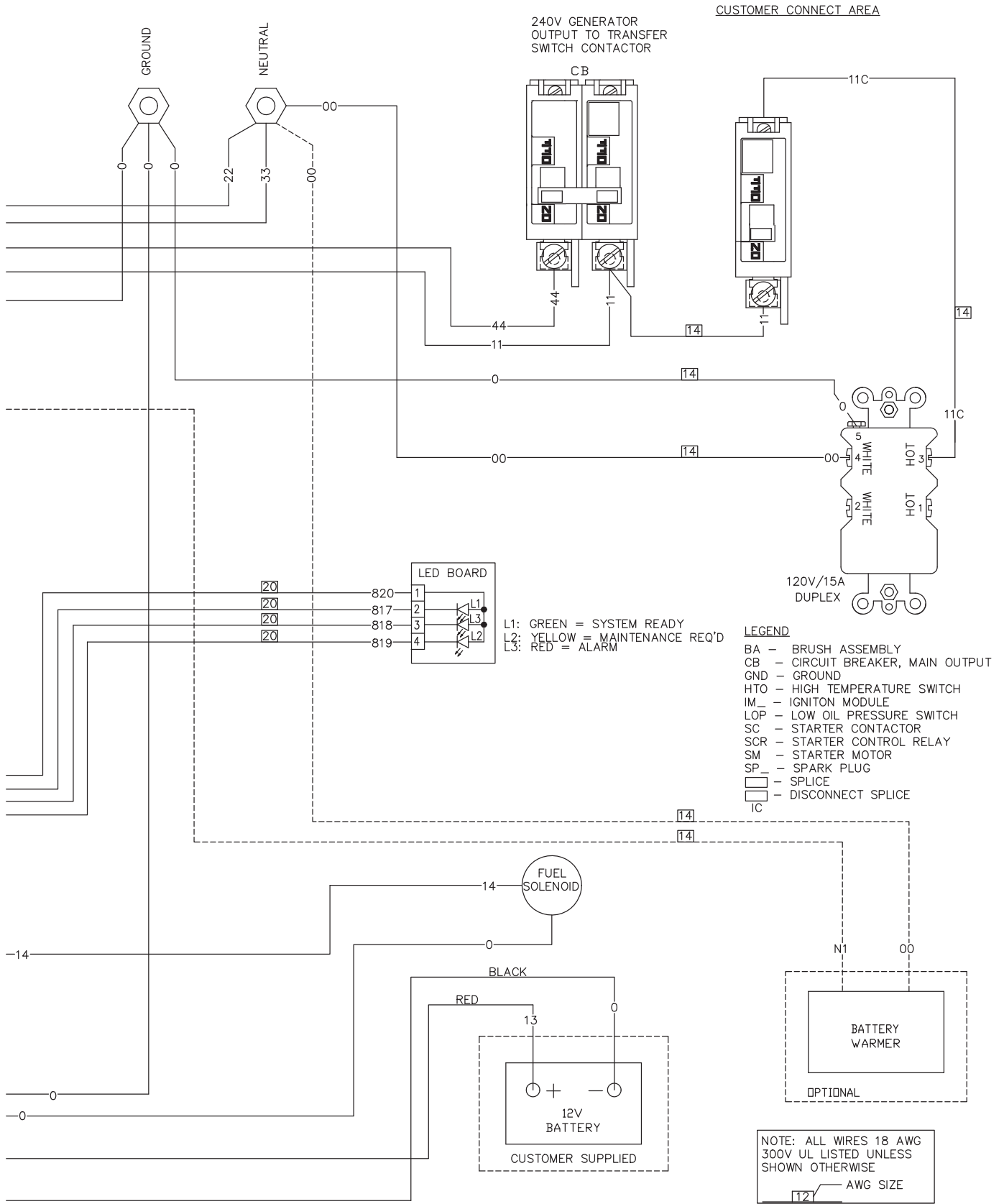
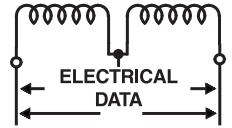

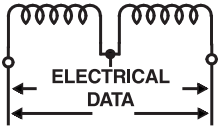

Electrical Data

Electrical Schematic - 20kW – Drawing No. 0G8515-A

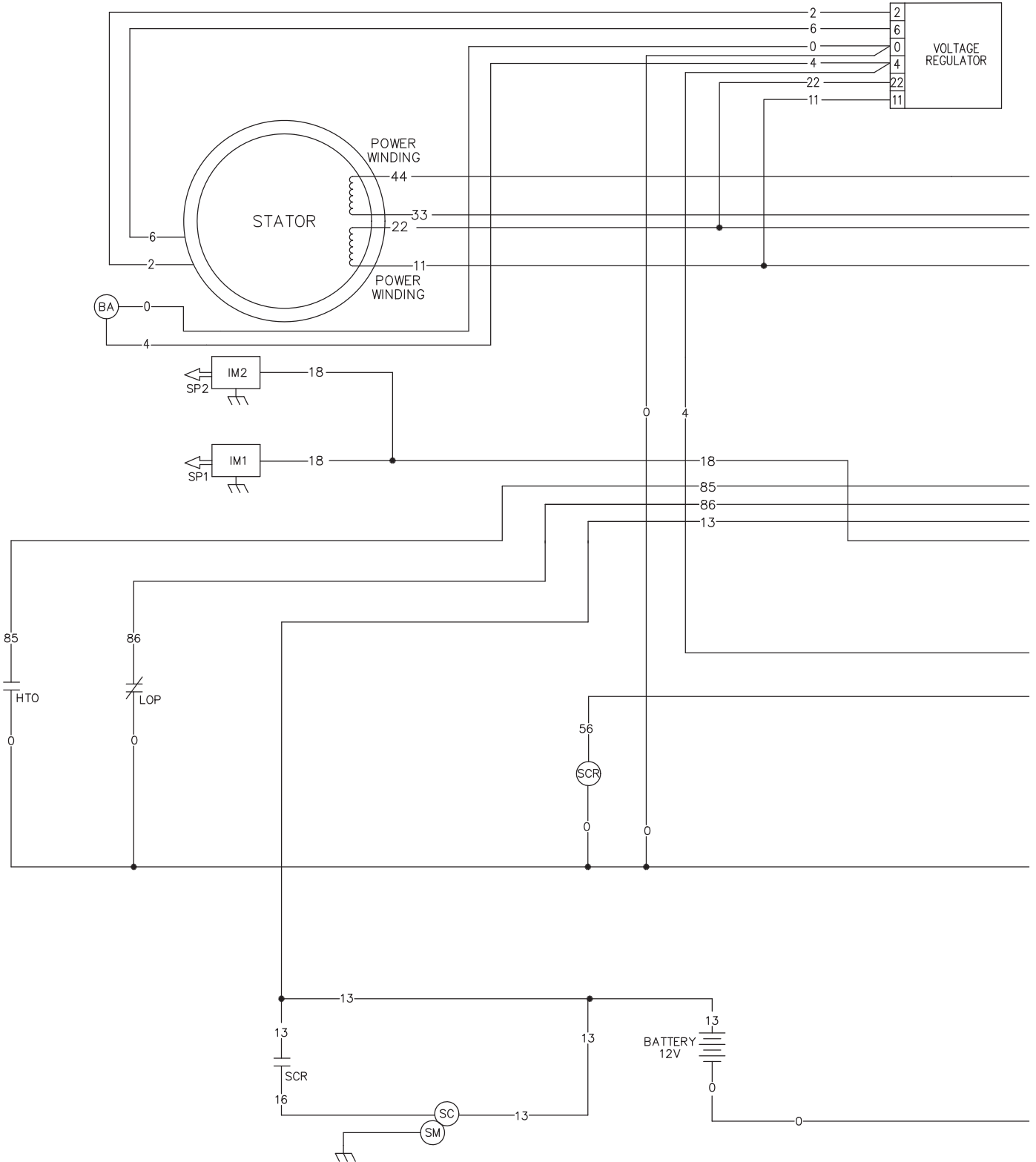

Electrical Data

Electrical Schematic - 20kW – Drawing No. 0G8515-A

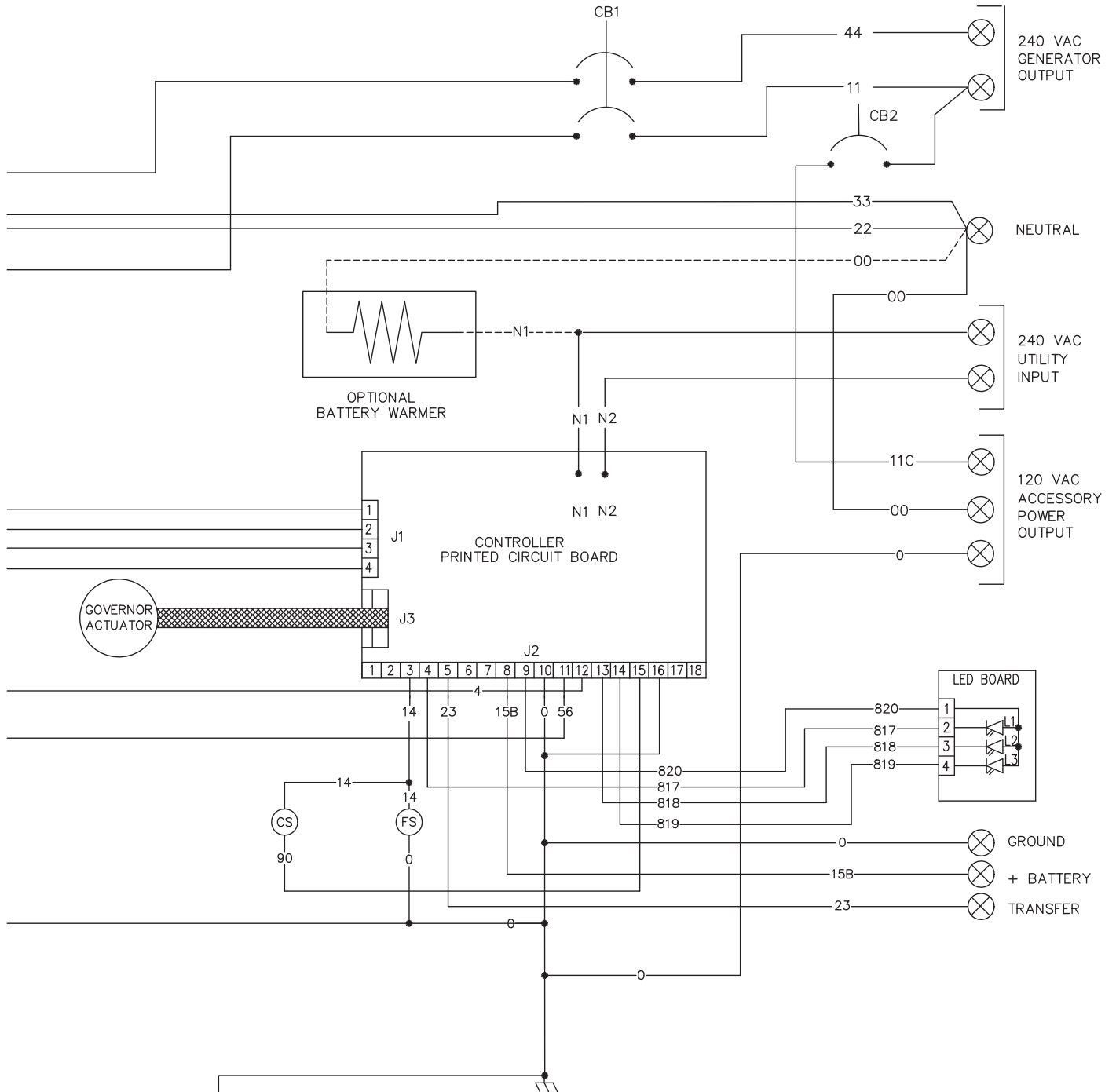
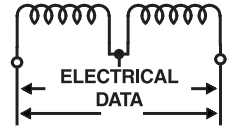

LEGEND
 BA - BRUSH ASSEMBLY
 CB_ - CIRCUIT BREAKER OUTPUT
 CS - CHOKE SOLENOID
 FS - FUEL SOLENOID
 HTD - HIGH TEMPERATURE SWITCH
 IM_ - IGNITION MODULE

LOP - LOW OIL PRESSURE SWITCH
 SC - STARTER CONTACTOR
 SCR - STARTER CONTROL RELAY
 SM - STARTER MOTOR
 SP_ - SPARK PLUG

