

# Installation Instructions

Upflow—Downflow  
Heating—Cooling

CJ5A Uncased Coil  
CK5A, CK5B Cased Coil

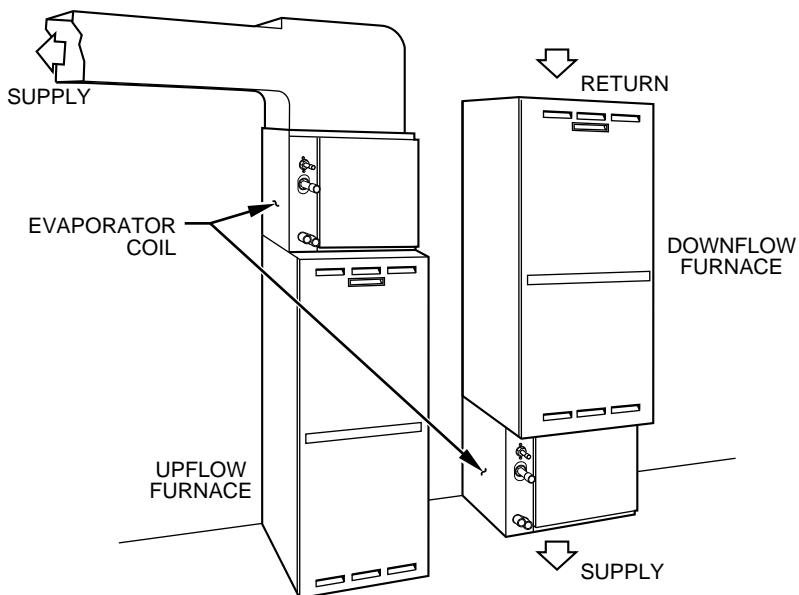

Fig. 1—Typical Coil Installation

A96244

**NOTE:** Read the entire instruction manual before starting the installation.  
This symbol → indicates a change since the last issue.

## SAFETY CONSIDERATIONS

Improper installation, adjustment, alteration, service, maintenance, or use can cause explosion, fire, electrical shock or other conditions which may cause personal injury or property damage. Consult a qualified installer, service agency, or your distributor or branch for information or assistance. The qualified installer or agency must use factory-authorized kits or accessories when modifying this product. Refer to the individual instructions packaged with the kits or accessories when installing.

Follow all safety codes. Wear safety glasses and work gloves. Use quenching cloth for brazing operations. Have fire extinguisher available. Read these instructions thoroughly and follow all warning or cautions attached to the unit. Consult local building codes and National Electrical Code (NEC) for special requirements.

It is important to recognize safety information. This is the safety-alert symbol . When you see this symbol on the unit and in instructions or manuals, be alert to the potential for personal injury.

Understand the signal words DANGER, WARNING, and CAUTION. These words are used with the safety-alert symbol. DANGER identifies the most serious hazards which **will** result in severe personal injury or death. WARNING signifies hazards which **could** result in personal injury or death. CAUTION is used to identify unsafe practices which **would** result in minor personal injury or product and property damage.

---

 **WARNING:** Before installing or servicing system, always turn off main power to system. There may be more than 1 disconnect switch. Turn off accessory heater power if applicable. Electrical shock can cause personal injury or death.

---

## INTRODUCTION

Use this instruction manual to install indoor coils on upflow or downflow furnaces. (See Fig. 1.) Do not install coil in horizontal position. Model CJ5A is an unenclosed bare coil, requiring a field-fabricated or accessory enclosure. Model CK5A is enclosed in a painted casing while model CK5B is available in an embossed clear coated casing.

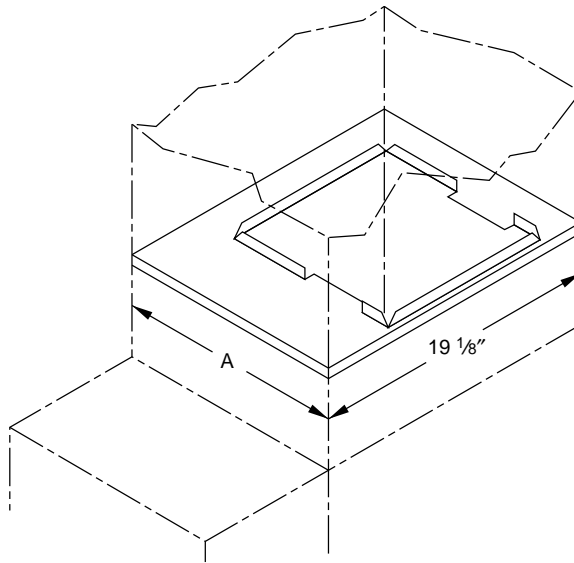

A96246

Dimensions (In.)

USED WITH CJ5A N-COIL SIZE	A
A018, A024, A030, N036	12-1/2
W024, W030, A036, N042, N048	15-13/16
W036, A042, A048, N060	19-3/8
W042, A060, X060	22-7/8

Fig. 2—Field Fabricated Mounting Support Shelf

### INSTALLATION

#### PROCEDURE 1—INSPECT EQUIPMENT

File claim with shipper if equipment is damaged or incomplete.

#### PROCEDURE 2—INSTALL COIL

##### A. Upflow CJ5A Uncased Furnace Coil Installation

**NOTE:** To select an accessory casing refer to Table 1 for available sizes.

1. Field fabricate mounting support shelf.
  - a. A corrugated template is shipped in each coil shipping box. Use this template as a guide in laying out the support shelf.
  - b. Place template on sheet metal shelf to trace opening.
  - c. Cut out sheet metal and bend up flanges as shown. (See Fig. 2.)
  - d. Locate and install coil support shelf 3-3/4 in. above furnace duct flanges in supply plenum.
2. Assemble support shelf and CJ5A coil. The assembly is designed to accommodate furnace opening. (See Fig. 3.)
3. Place casing or plenum on furnace. If casing is used slide coil assembly in until rear seal contacts rear panel of enclosure. (See Fig. 4.)
4. Make sure that right side of support shelf does not block off any of the coil opening.
5. Attach front access panel to coil enclosure.

**IMPORTANT:** If CJ5A uncased coil is mounted on furnace directly inside plenum without a coil casing, affix caution label attached to instruction sheet to right side of plenum enclosure. (See Fig. 5.)

6. Insulate enclosure.

→ Table 1—Accessory Casing for CJ5A N-Coil

CASING PART NO. PER SKID	DIMENSIONS PER INDIVIDUAL CASING (IN.)			COIL SIZE USAGE
	Height	Width	Depth	
KCAKC0612ECC	17-3/16	14-3/16	21	A018, A024, A030, N036
KCAKC0712ECC	19-1/8	17-1/2	21	W024, W030, A036, N042, N048
KCAKC0404ECC	24-15/16	21	21	W036, A042, A048, N060
KCAKC0904ECC	24-15/16	24-1/2	21	W048, A060, X060

##### B. Upflow CK5A/CK5B Cased Furnace Coil Installation

All cased coils are designed to directly match the furnace width. (See Table 2.) Under hanging or overhanging installations are not necessary or advised with the N-coil design.

**Table 2—Furnace Widths**

CK5A/CK5B CASED COILS	FURNACE WIDTHS (IN.)
A018, A024, A030, N036	14-3/16
W024, W030, A036, N042, N048	17-1/2
W036, A042, A048, N060	21
W048, A060, X060	24-1/2

1. Set coil in place on upflow furnace discharge air opening. (See Fig. 1.)
2. Ensure coil is level for proper condensate drainage. Do not tip coil toward condensate drain. Coil enclosure need not be fastened or screwed to furnace.

**C. Downflow CK5A/CK5B Coil Installation**

Place N-coil on supply duct opening. Place furnace on top of N-coil casing.

**PROCEDURE 3—CONNECT REFRIGERANT PIPING**

Refrigerant piping must be configured per local building codes. Lay out piping in relation to specifications and job site requirements.

→ **PROCEDURE 4—CONNECT REFRIGERANT LIQUID AND SUCTION LINES**

For matched and mix matched systems, use line sizes recommended in outdoor unit Installation Instructions.

The coil can be connected to outdoor units using accessory tubing packages or field-supplied tubing of refrigerant grade. Always evacuate tubing and reclaim refrigerant when making connections or flaring tubing. Leak check connections before insulating entire suction line.

---

**⚠ CAUTION: If unit is to be installed on system with a thermostatic expansion valve, removal of the indoor coil piston is required.**

---

**A. Suction Line**

Suction line is designed for field sweat connection. Line is plugged to keep out moisture and dirt. Remove these plugs only when ready to make connection.

**NOTE:** Use hole location template located on flap of carton to mark hole centers on sheet metal door for liquid, suction, and condensate drain lines.

---

**⚠ CAUTION: To avoid valve damage while brazing, wrap tubing or fittings with a heat-sinking material such as a wet cloth.**

---

**B. Liquid Line**

Liquid line is designed for sweat connection. During installation the following steps should be followed.

1. Remove rubber plug.
2. Replace piston if required. Check the piston size stamped into side of brass hex nut. (See Fig. 6.) If this piston number does not match required piston shown on outdoor unit rating plate, replace indoor piston with piston shipped with outdoor unit.

---

**⚠ CAUTION: Use a back up wrench to loosen and re-tighten nut.**

---

**System Refrigerant Control**

A refrigerant control device (bypass type) is factory supplied with coil. (See Table 3.) The piston has a refrigerant metering hole through it, and is field replaceable.

The piston shipped with the indoor coil may be different from the piston shipped with the outdoor condensing unit. If this is the case you may need to change the indoor piston. Always use the piston shipped with the outdoor condensing unit.

**Table 3—Refrigerant Metering Device**

MODELS CJ5A, CK5A, AND CK5B	FACTORY-SHIPED PISTON NO.
A018	52
A024, W024	59
A030, W030	67
A036, W036, N036	70
A042, N042	78
A048, W048, N048	84
A060, X060, N060	90

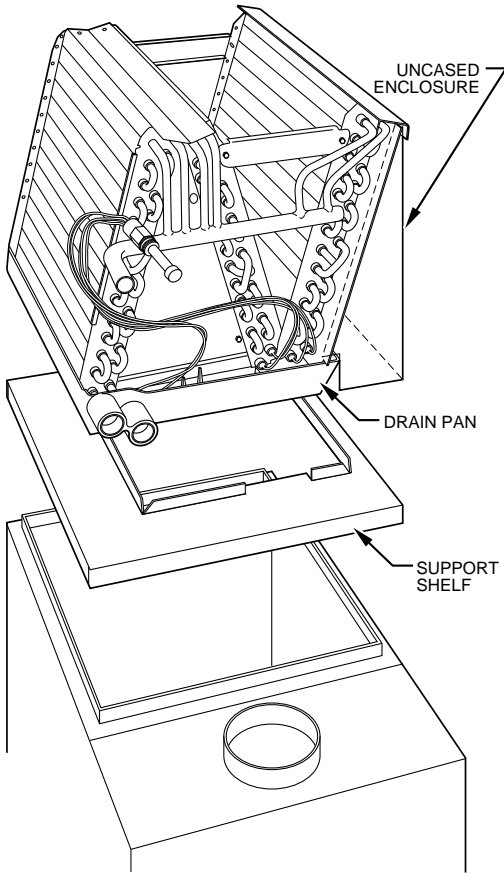

Fig. 3—Furnace opening and N-Coil with Support Shelf

A96245

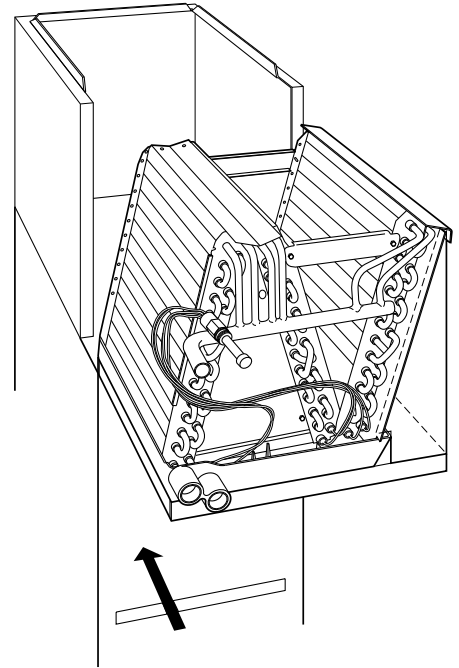

Fig. 4—Placing N-Coil Assembly Into Casing

A96247



Fig. 5—Plenum Caution Label

A96359

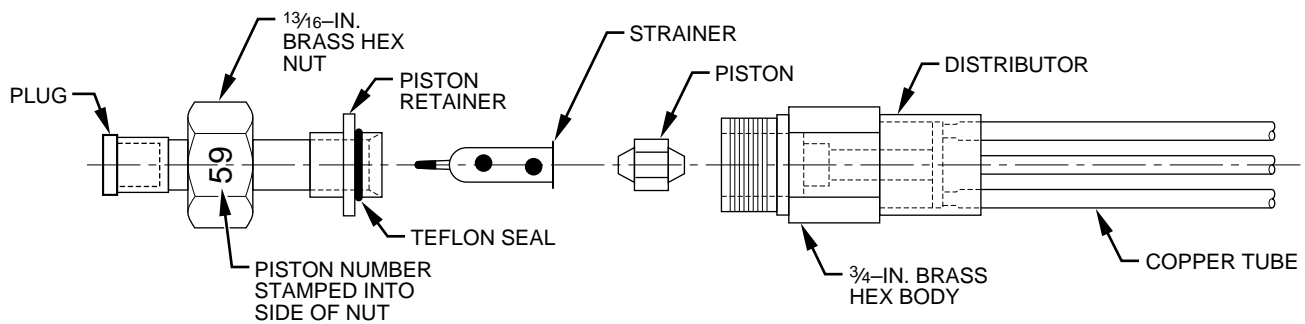

Fig. 6—Refrigerant Control Device Components

A96248

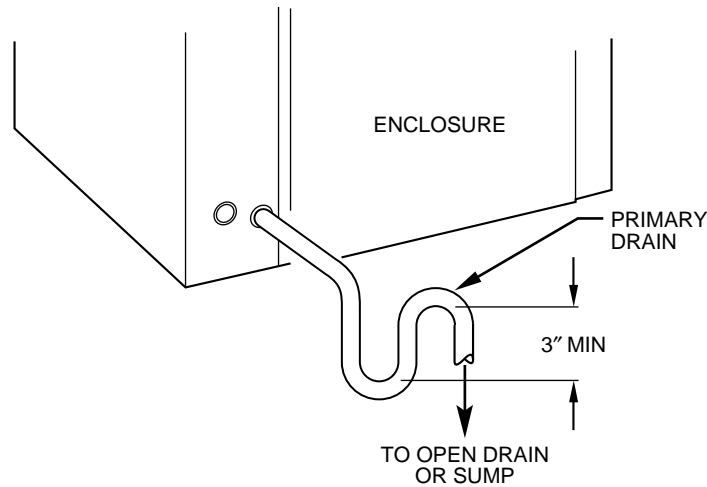

Fig. 7—Condensate Trap

A88571

**⚠ CAUTION: DO NOT BURY MORE THAN 36 IN. (914mm) OF REFRIGERANT TUBING IN GROUND.** If any section of tubing is buried, there must be a 6-in. (152mm) vertical rise to the valve connections on the outdoor unit. If more than the recommended length is buried, refrigerant may migrate to cooler buried section during extended periods of unit shutdown, causing refrigerant slugging and possible compressor damage at start-up.

**NOTE:** Wrap a wet cloth around rear of fitting to prevent damage to factory-made joints.

**PROCEDURE 5—MAKE CONDENSATE DRAIN LINE CONNECTION**

The coil is designed to dispose of accumulated water through built-in condensate drain fitting. Two 3/4-in. female threaded pipe connections are provided in each coil.

Install a trap in condensate line of CJ5A, CK5A, or CK5B coil as close to coil as possible. Make trap at least 3 in. deep and not higher than bottom of unit condensate drain opening. (See Fig. 7.) Pitch condensate line to open drain or sump.

When coil is installed over a finished ceiling and/or living area, a secondary sheet metal condensate pan must be constructed and installed under entire unit.

→ **PROCEDURE 6—HUMIDIFIER APPLICATION**

When installing a humidifier in a system which contains an N-Coil, consideration must be given to location of coil.

1. Care must be taken to prevent damage of N-Coil when attaching humidifier to coil casing or plenum.
2. Ensure that humidifier has adequate airflow.

The humidifier may be applied to left side of the coil enclosure or above coil slab on right side. (See Fig. 8.)

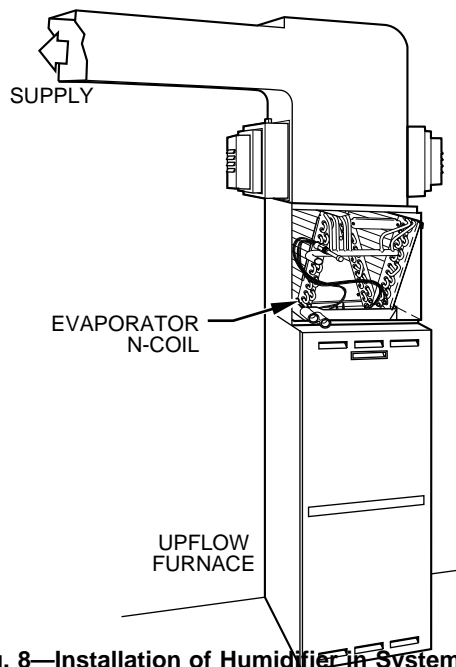

→ Fig. 8—Installation of Humidifier in System with N-Coil

A96401

# SERVICE TRAINING

**Packaged Service Training** programs are an excellent way to increase your knowledge of the equipment discussed in this manual, including:

- Unit Familiarization
- Maintenance
- Installation Overview
- Operating Sequence

A large selection of product, theory, and skills programs is available, using popular video-based formats and materials. All include video and/or slides, plus companion book.

**Classroom Service Training** plus "hands-on" the products in our labs can mean increased confidence that really pays dividends in faster troubleshooting, fewer callbacks. Course descriptions and schedules are in our catalog.

**CALL FOR FREE CATALOG 1-800-962-9212**

Packaged Service Training

Classroom Service Training



