

Installation Instructions

Cased Horizontal
Furnace Coil

CK3B

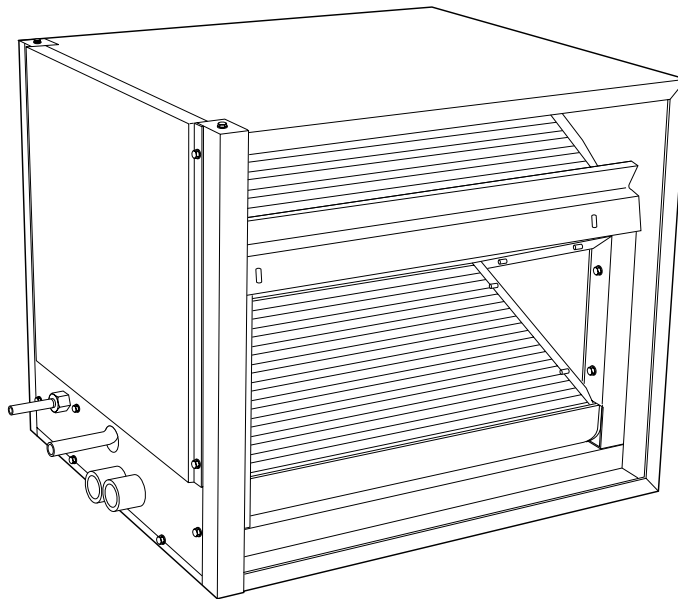

A96318

Fig. 1—Model CK3B Furnace Coil

NOTE: Read the entire instruction manual before starting the installation.

SAFETY CONSIDERATIONS

Improper installation, adjustment, alteration, service, maintenance, or use can cause explosion, fire, electrical shock or other conditions which may cause personal injury or property damage. Consult a qualified installer, service agency, or your distributor or branch for information or assistance. The qualified installer or agency must use factory-authorized kits or accessories when modifying this product. Refer to the individual instructions packaged with the kits or accessories when installing.

Follow all safety codes. Wear safety glasses and work gloves. Use quenching cloths for brazing operations. Have fire extinguisher available. Read these instructions thoroughly and follow all warnings or cautions attached to the unit. Consult local building codes and National Electrical Codes (NEC) for special requirements.

It is important to recognize safety information. This is the safety-alert symbol . When you see this symbol on the unit and in instructions or manuals, be alert to the potential for personal injury.

Understand the signal words DANGER, WARNING, CAUTION, and NOTE. These words are used with the safety-alert symbol. DANGER identifies the most serious hazards which **will** result in severe personal injury or death. WARNING signifies hazards which **could** result in personal injury or death. CAUTION is used to identify unsafe practices, which **would** result in minor personal injury or product and property damage. NOTE is used to highlight suggestions which **will** result in enhanced installation, reliability, or operation.

→  **WARNING:** Before installing or servicing system, always turn off main power to system. There may be more than one disconnect switch. Turn off accessory heater power if applicable. Electrical shock can cause personal injury or death.

→  **CAUTION:** This coil contains Nitrogen precharge of 15 PSIG. Release of this pressure through the center of the rubber plugs is required before removing the plugs. Failure to follow this CAUTION could result in minor personal injury or product and property damage.

IMPORTANT: Nitrogen can leak out through the needle pierce hole in the plugs. This does not indicate a leaking coil nor warrant return of the coil.

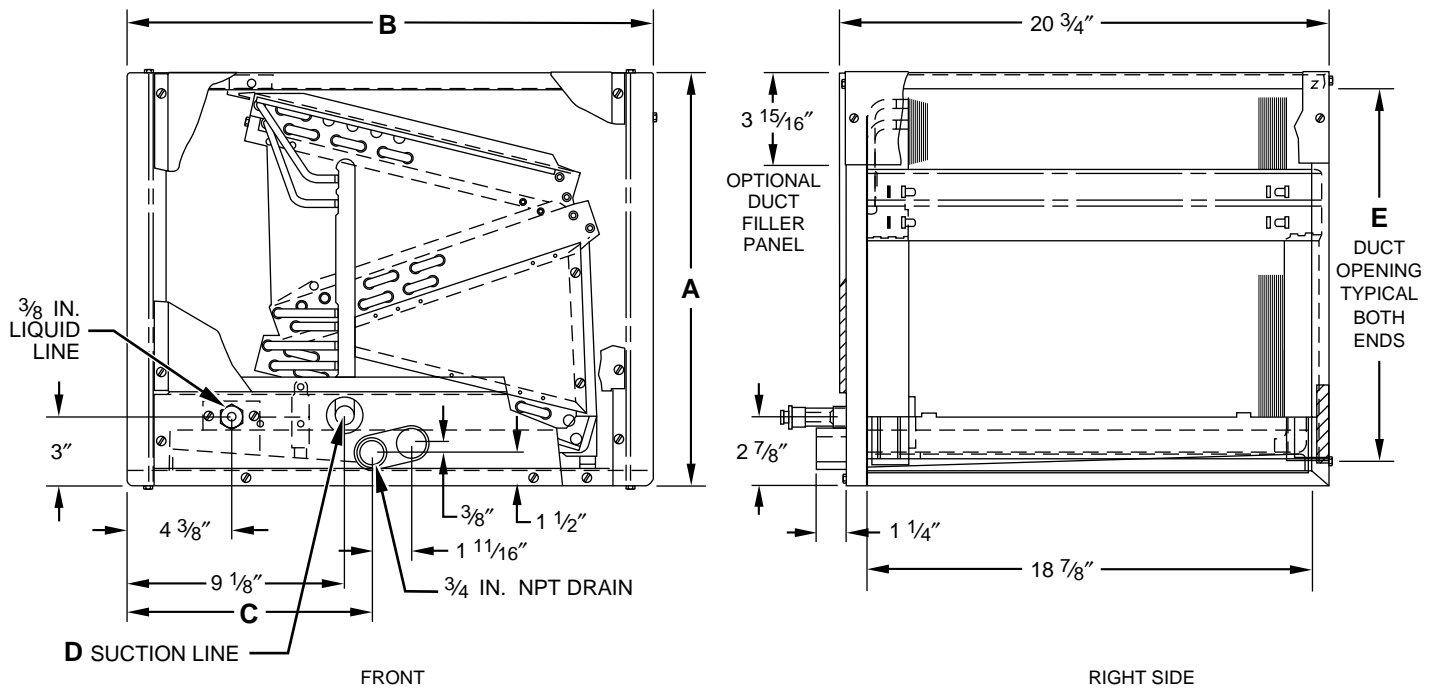

A97521

UNIT	A (IN.)	B (IN.)	C (IN.)	D (IN.)	E (IN.)	SHIPPING WEIGHT (LB)
CK3BXA024(0,T)17	17-9/16	19-1/16	10-1/16	5/8	16	37.0
CK3BXA030(0,T)17	17-9/16	19-1/16	10-1/16	3/4	16	40.5
CK3BXA036(0,T)17	17-9/16	22-1/16	10-1/4	3/4	16	45.5
CK3BXA042(0,T)21	21-1/16	22-1/16	10-1/4	7/8	19-1/2	47.0
CK3BXA048(0,T)21	21-1/16	22-1/16	10-1/4	7/8	19-1/2	51.0
CK3BXA060(0,T)24	24-9/16	28-1/8	13-3/16	7/8	23	64.0

Note: For the 10th digit position in the model number, 0 = standard copper coil and T = tin-plated copper coil.

→ Fig. 2—Dimensional Drawing

INTRODUCTION

The CK3B is a horizontal, multi-use cased furnace coil. (See Fig. 1.) With the use of field-supplied transition duct, these furnace coils can also be applied to other similar horizontal furnaces on the market. The CK3B is available in sizes 024 through 060. (See Fig. 2.)

NOTE: Models with tin-plated copper coils ("T" in the 10th position of the model number) are installed the same as standard copper coils.

INSTALLATION

The unit can be installed on a work platform, secured to roof truss in an attic, suspended from hangers on floor joists in crawl space, or installed on blocks. It is designed to allow airflow in either direction, to mate with horizontal-left (see Fig. 5) or horizontal-right (see Fig. 6) furnace installations.

NOTE: Before placing ductwork on casing opening, check the rubber grommet (see Fig. 3) to ensure that the grommet is located so the bottom end is within the condensate pan. Moisture on the header tube will run down the grommet and drip into the pan.

NOTE: Remove shipping brace from both ends of casing prior to installation. Also remove corrugated shipping block from inside the right end of casing prior to installation.

PROCEDURE 1—FURNACE ATTACHMENT

A. Attach coil to furnace.

The attachment plates (3) and filler plate (1) are packaged together and placed in coil carton. Remove these items, verifying the correct amount. Use the following procedure to attach CK3B horizontal coil to furnace.

1. Three attachment plates are used to attach coil to furnace. Application determines which end of the coil will be attached to the furnace.
2. Use self-tapping screws to mount attachment plates to coil casing. (See Fig. 4A.)
3. Connect furnace snugly against coil casing.
4. Use self-tapping screws to attach furnace. (See Fig. 4B.)
5. Seal joint between coil casing and furnace to create air tight seal using locally approved materials.

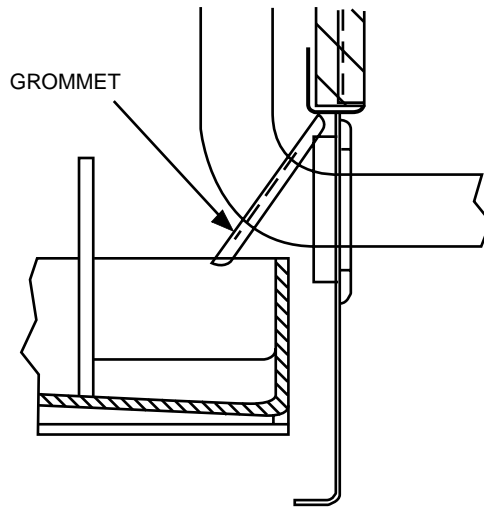

Fig. 3—Grommet Location

A00188

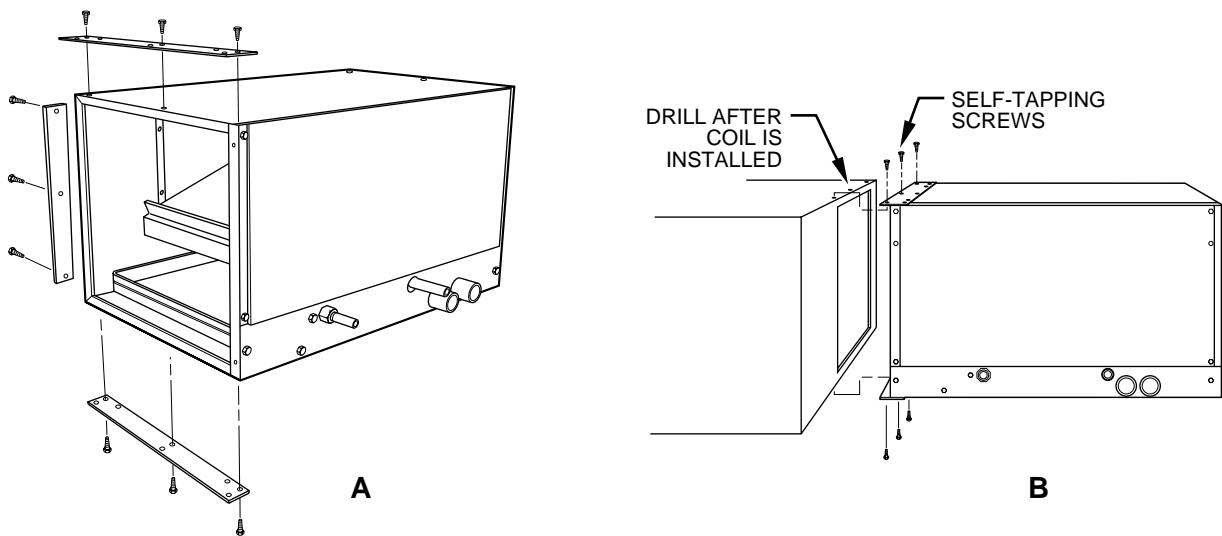

Fig. 4—Duct Flange Assembly

A97201

PROCEDURE 2—HORIZONTAL ATTIC INSTALLATION

A. Construct work platform to support coil/furnace combination.

1. Construct work platform, using material in platform that will support the weight of an installer or a service person.
2. Place work platform in front of discharge end of furnace.
3. Secure platform to building joists.

B. Install coil.

To suspend CK3B:

1. Cut plumbers strap to desired lengths.
2. Attach plumbers strap to 4 corners of coil casing. (See Fig. 7.)
3. Use a minimum of 2 screws per corner to attach plumbers strap to casing.
4. Position and secure coil in front of furnace discharge end.
5. Make sure coil is level for proper condensate drainage.
6. Using appropriate fasteners for duct type, connect supply-air duct to coil.
7. Coils are shipped with a filler plate included in the package for use when coil is coupled with a narrow furnace. Attach filler plate between coil flange in furnace as shown in Fig. 5 and 6.

PROCEDURE 3—HORIZONTAL CRAWL SPACE INSTALLATION

As an alternate to horizontal attic installation, the CK3B horizontal coil can be installed in a crawl space by mounting on suitable blocks, pads or by hanging from floor joists.

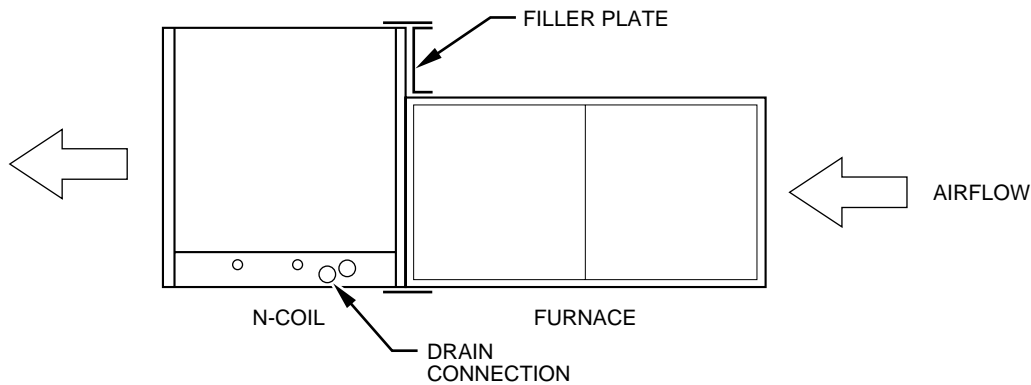

A97203

Fig. 5—Horizontal Left Installation with Filler Plate

To suspend CK3B:

1. Cut plumbers strap to desired lengths.
2. Attach plumbers strap to 4 corners of coil casing (See Fig. 7).
3. Use a minimum of 2 screws per corner to attach plumbers strap to casing.
4. Position and secure coil in front of furnace discharge end.
5. Make sure coil is level for proper condensate drainage.
6. Using appropriate fasteners from duct type, connect supply-air duct to coil.

PROCEDURE 4—REFRIGERANT LINES

Refrigerant lines must be configured per local building codes. Lay out lines in relation to specifications and job site requirements.

PROCEDURE 5—CONNECT REFRIGERANT LIQUID AND SUCTION LINES

For matched and mismatched systems, use line sizes recommended in outdoor unit Installation Instructions.

The coil can be connected to outdoor units using accessory refrigerant line sets or field-supplied lines of refrigerant grade. Always evacuate lines and reclaim refrigerant when making connections or flaring refrigerant lines. Leak check connections before insulating entire suction line.

⚠ CAUTION: If unit is to be installed on system with a thermostatic expansion valve, removal of indoor coil piston is required. Failure to follow this CAUTION could result in minor personal injury or product and property damage.

A. Suction Line

Suction line is designed for field sweat connections. Provide inverted loop on suction line if line set exceeds 50 ft. per long line application guide. Sweat stub has a rubber shipping plug to keep out moisture and dirt. Remove plug only when ready to make field sweat connection.

⚠ CAUTION: To avoid damage while brazing, wrap tubing or fittings with a heat-sinking material such as a wet cloth. Failure to follow this CAUTION could result in minor personal injury or product and property damage.

B. Liquid Line

Liquid line is designed for sweat connection. During installation these steps should be followed:

1. Replace piston, if required. Check piston size stamped into side of brass hex nut. (See Fig. 8.) If piston number does not match required piston shown on outdoor unit rating plate, replace indoor piston with piston shipped with outdoor unit.
2. When piston is replaced finger tighten plus 1/4 turn.

⚠ CAUTION: Remove Teflon seal during brazing. Replace when fitting has cooled. Failure to follow this CAUTION could result in minor personal injury or product and property damage.

3. Liquid stub has a rubber shipping plug to keep out moisture and dirt. Remove plug only when ready to make field sweat connection.

SYSTEM REFRIGERANT CONTROL

A refrigerant control device (bypass type) is factory supplied with coil. (See Table 2.) The piston has a refrigerant metering hole through it, and is field replaceable.

The piston shipped with indoor coil may be different from piston shipped with outdoor condensing unit. If this is the case, change the indoor piston. Always use piston shipped with outdoor condensing unit.

PROCEDURE 6—CONNECT CONDENSATE DRAIN LINE

The CK3B coil is designed to dispose of accumulated water through built-in condensate drain fittings. It is recommended that PVC fittings be used on the condensate pan. Do not over-tighten. Finger tighten plus 1-1/2 turns. Be sure to install plastic plug in unused condensate drain fitting.

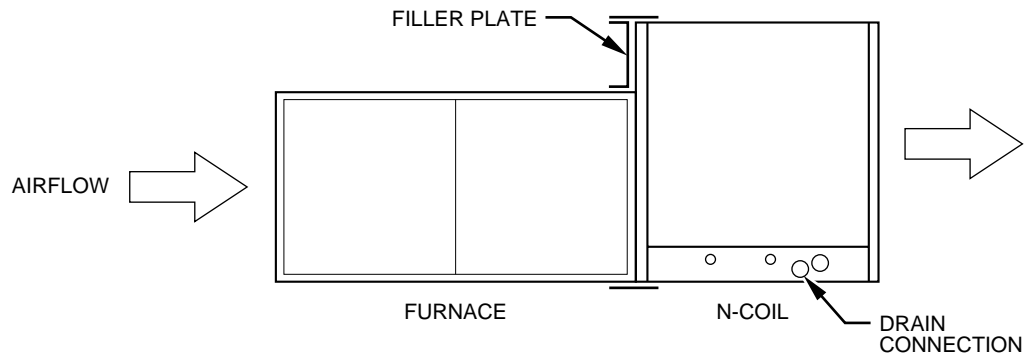

A97037

Fig. 6—Horizontal Right Installation with Filler Plate

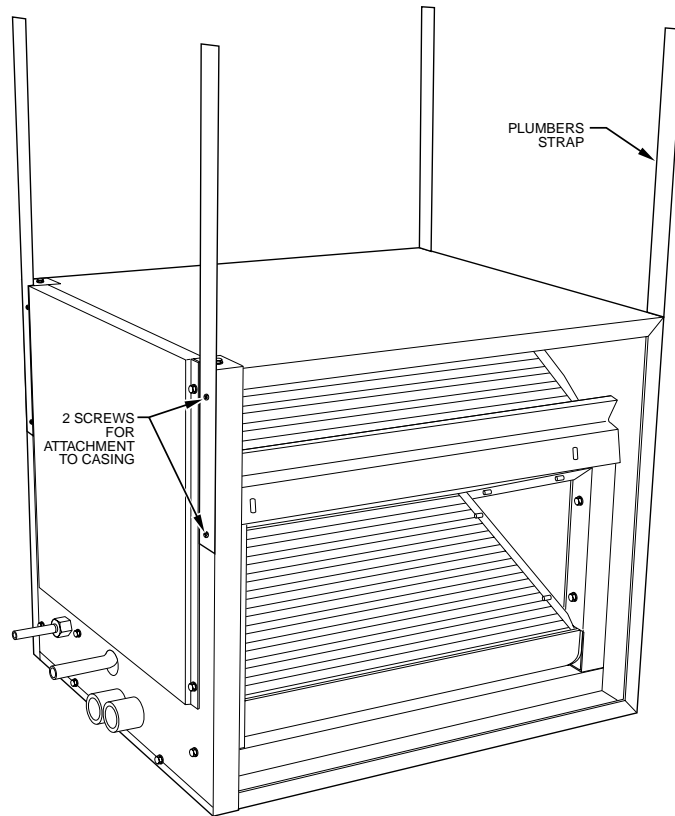

A97014

Fig. 7—CK3B Suspension with Plumbers Strap

Table 2—Refrigerant Metering Device

MODEL CK3B COIL SIZE	PISTON NUMBER
024	59
030	67
036	70
042	78
048	84
060	90

Install a trap in condensate line as close to the CK3B coil as possible. Make trap at least 2-1/4 in. deep and not higher than the bottom of unit condensate drain openings. (See Fig. 9.)

NOTE: If unit is located in or above a living space where damage may result from condensate overflow, a field-supplied, external condensate pan should be installed under the entire unit, and a secondary condensate line (with appropriate trap) should be run from unit into pan. Any condensate in this external condensate pan should be drained to a noticeable place. As an alternative to using an external condensate pan, some localities may allow the running of a separate 3/4-in. condensate line (with appropriate trap) to a place where condensate will be noticeable. The owner of the structure must be informed that when condensate flows from the secondary drain or external condensate pan, the unit requires servicing or water damage will occur.

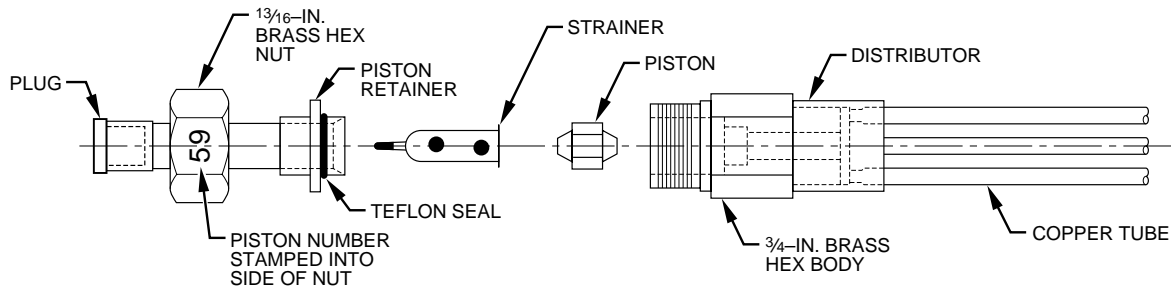

A96248

Fig. 8—Refrigerant Control Device Components

Install traps in condensate lines as close to coil as possible. (See Fig. 9.) Make sure that outlet of each trap is below its connection to condensate pan to prevent condensate from overflowing drain pan. Prime all traps, test for leaks, and insulate traps and lines if located above a living area. Consult local codes for additional restrictions or precautions.

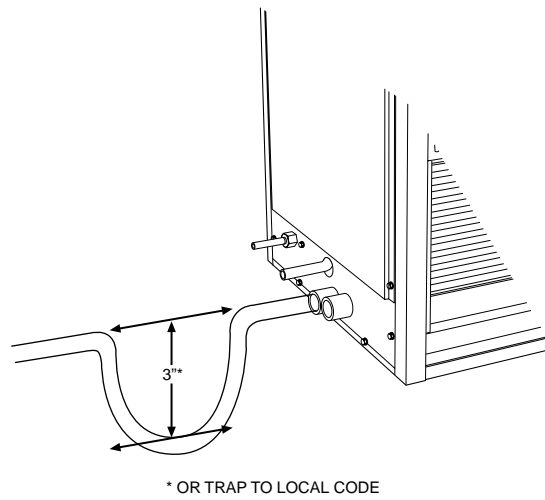

A03087

Fig. 9—Condensate Trap

SERVICE TRAINING

Packaged Service Training programs are an excellent way to increase your knowledge of the equipment discussed in this manual, including:

- Unit Familiarization • Maintenance
- Installation Overview • Operating Sequence

A large selection of product, theory, and skills programs is available, using popular video-based formats and materials. All include video and/or slides, plus companion book.

Classroom Service Training plus "hands-on" the products in our labs can mean increased confidence that really pays dividends in faster troubleshooting, fewer callbacks. Course descriptions and schedules are in our catalog.

CALL FOR FREE CATALOG 1-800-644-5544

[] Packaged Service Training [] Classroom Service Training

