

Installation Instructions

Barometric Bypass Damper

DAMPBAR08X14
DAMPBAR08X24

NOTE: Read the entire instruction manual before starting the installation.

SAFETY CONSIDERATIONS

Improper installation, adjustment, alteration, service, maintenance, or use can cause explosion, fire, electrical shock, or other conditions which may cause personal injury or property damage. Consult a qualified installer, service agency, or your distributor or branch for information or assistance. The qualified installer or agency must use factory-authorized kits or accessories when modifying this product. Refer to the individual instructions packaged with the kits or accessories when installing.

Follow all safety codes. Wear safety glasses and work gloves. Have fire extinguisher available. Read these instructions thoroughly and follow all warnings or cautions attached to the unit. Consult local building codes and National Electrical Code (NEC) for special requirements.

Recognize safety information. This is the safety-alert symbol . When you see this symbol on the unit and in instructions or manuals, be alert to the potential for personal injury.

Understand the signal words DANGER, WARNING, and CAUTION. These words are used with the safety-alert symbol. DANGER identifies the most serious hazards which **will** result in severe personal injury or death. WARNING signifies hazards which **could** result in personal injury or death. CAUTION is used to identify unsafe practices which **would** result in minor personal injury or product and property damage.

INTRODUCTION

The Barometric Bypass Damper is designed to control the operating pressure in the supply air system. The Bypass Damper is a mechanical device which requires no electrical wiring or power. The bypass operation is controlled by the difference in pressure between the damper inlet and the damper outlet.

NOTE: Because the operating pressures and control forces are relatively small, **ensure there is no binding or drag on the damper blade after installation.** Failure to verify this may prevent the damper from operating properly.

SPECIFICATIONS

Operating Range: -10° to 175°F (-23° to 80°C)

Pressure Range: 0.40 to 1.20 in. wc.

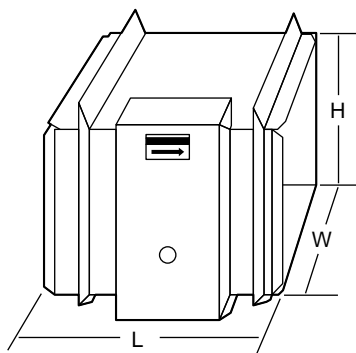

A98131

MODEL NO.	HEIGHT (IN.)	WIDTH (IN.)	LENGTH (IN.)	MAXIMUM AIR-FLOW (CFM)
DAMPBAR08X14	8	14	13-3/4	1200
DAMPBAR08X24	8	24	13-3/4	1800

Fig. 1—Barometric Bypass Dimensions

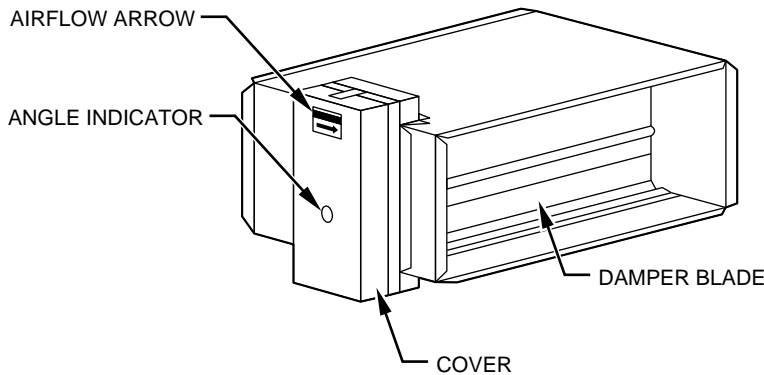

A98127

Fig. 2—Barometric Bypass Damper

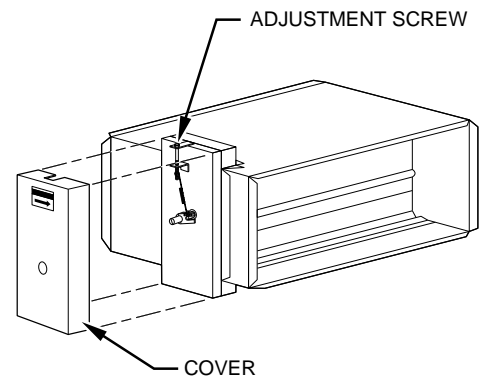

A98128

Fig. 3—Mechanism Cover Removal

INSTALLATION

PROCEDURE 1—FIND A LOCATION TO MOUNT DAMPER.

This location should be accessible to allow inspection and adjustment of damper after installation. The following must be performed:

1. The air must flow through the Bypass Damper in the direction indicated by the "airflow" arrow. See Fig. 2.
2. The mechanism cover must have enough clearance to allow it to be removed after installation. See Fig. 3. The damper should be oriented to allow the angle indicator to be easily seen. See Fig. 2.
3. The adjustment screw must be accessible. See Fig. 3.
4. The damper must connect to the supply air system **after leaving air temperature sensor**. The air flowing through the Bypass Damper must have first passed by the leaving air temperature sensor.

PROCEDURE 2—DIRECT RETURN METHOD

The direct return method involves routing the supply air directly back into the return.

1. If possible, mount the Bypass Damper in a horizontal position. The damper may be mounted vertically if required. See Fig. 4.

For best results, the damper should be placed as far from the air handler unit as possible. The intention is to create a long flow path for the air leaving the Bypass Damper. This helps mix the bypass and return air prior to entering the air handler unit.

2. To avoid problems with sweating, cover the Bypass Damper with a minimum of 1-in. thick insulation. The thickness and insulation material must be approved by the local building official. Do not use uninsulated duct work in areas where condensing may occur.
3. **DO NOT** connect the bypass discharge into ANY PART of the return air system or plenum unless the following is performed:

The discharge must be connected to the return air system prior to any air filters. In other words, all of the bypassed air must pass through the system air filters prior to re-entering the air handler unit. The reason is to prevent the pressure difference, which controls the bypass, from changing as the system operates. Otherwise as the air filter becomes dirty, the pressure across the bypass could increase. This would cause a greater quantity of air to pass through the Bypass Damper than is required.

The bypass discharge must be as close to room static pressure as possible.

PROCEDURE 3—DUMP ZONE METHOD

The dump zone method involves using a portion of the house as a dump zone. See Fig. 5.

1. When connecting the discharge to a return air system, or near a return air grille, always use a few feet of lined, rigid duct work (8 to 15 ft) to reduce noise.

NEVER install the Barometric Bypass Damper using flexible duct work. It is possible to connect the bypass discharge to a ceiling supply air grille if desired, when discharging the bypass air into a dump area.

2. Bypass sizing is critical. Directly returning great quantities of air to the return air system will result in duct temperature limits being exceeded and the system cycling on its safety limit devices. If this condition exists, it is required that the bypassed air be limited further or directed to living spaces either with a ceiling grille or other means and allow the bypassed air to be tempered prior to entering the air handler.

ADJUSTMENT OF THE BYPASS DAMPER

Final adjustment of the Barometric Bypass Damper is performed after the system is operating. The factory setting for the bypass is approximately 0.75 in. wg. This pressure set point is the difference between the inlet and discharge bypass duct pressures. To measure this, connect a U-tube manometer to the bypass duct work with 1 connection 2 ft upstream of the bypass and the other 2 ft downstream.

The bypass pressure setting should be as high as possible. There should be as much air as possible entering the supply air duct work rather than passing through the Bypass Damper. The pressure setting will generally be fixed by the noise in the duct system. If diffusers in the individual zones are noisy, then reduce the pressure setting until a satisfactory setting is achieved.

1. To INCREASE the pressure setting, turn the adjustment screw clockwise.
2. To DECREASE the pressure setting, turn the adjustment screw counter-clockwise.

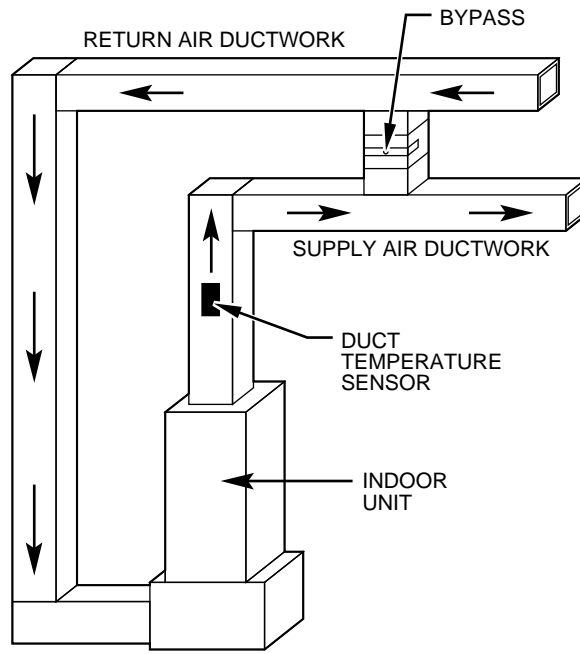

Fig. 4—Direct Return Installation

A98129

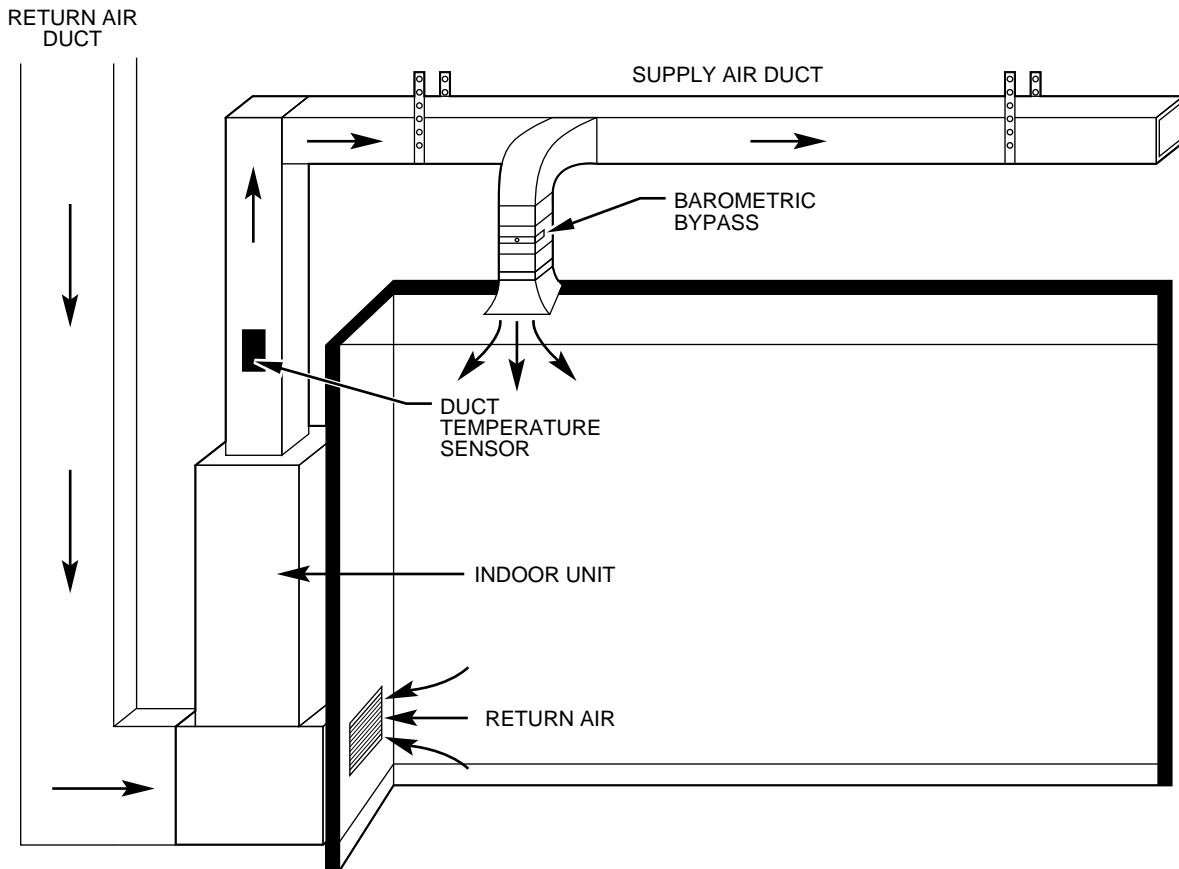

Fig. 5—Dump Zone Installation

A98130

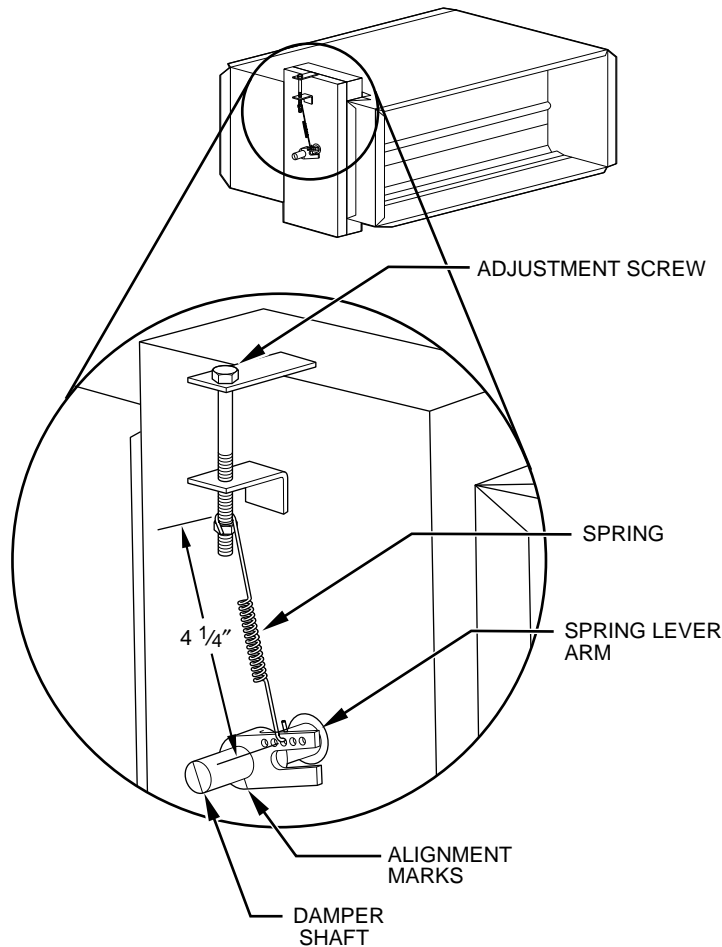

Fig. 6—Barometric Bypass Adjustment

A98132

The adjustment screw is used for fine adjustment. (See Fig. 6.) To make greater changes in the operating pressure, change the spring connection on the spring lever arm. To perform this, remove the mechanism cover by removing the 4 attachment screws. Once removed, the spring and the spring lever arm attached to the damper blade shaft will be visible.

The spring lever arm has a series of 5 holes in it. These holes are used as attachment points for the damper spring. For reference purposes, the holes are numbered 1 to 5 with No. 1 being the closest to the damper blade shaft. These numbers ARE NOT embossed on the spring lever arm.

The mounting holes closer to the damper shaft are for lower operating pressures. The mounting holes further from the damper shaft are for higher pressures. To change the spring setting, unhook the spring from the lever arm and hook it into the desired mounting hole. Now use the screw adjustment for finer adjustments.

Each mounting hole will change the pressure set point approximately 0.25 in. wg. starting at 0.40 to 0.50 in. wg. at the mounting hole (No. 1) closest to the damper blade shaft. As the spring moves from the nearest holes, the pressure will increase. The highest pressure recommended is approximately 1.25 in. wg.

The static pressure should be set as high as possible without creating unacceptable noise when the duct system is most restricted. When connected as a direct bypass, no more than 25 percent of the air through the air handler should be bypassed. Refer to the Zoning Design Application Guide for further information.

RESETTING THE DAMPER TO FACTORY SET POINTS

It is possible to reset the Barometric Bypass Damper to the factory settings by performing the following:

1. Verify that the alignment marks on the end of the damper blade shaft and the spring lever arm are aligned. (See Fig. 6.)
2. Ensure that the damper blade is free to rotate and that there is no binding.
3. Mount the damper spring in hole No. 3 on the spring lever arm. This **MUST BE** the original spring or an approved equal.
4. Use the adjustment screw to change the spring length while it is installed. The spring should be adjusted so that the spring measures 4-1/4 in., measured from spring hook to spring hook.
5. This should set the Barometric Bypass Damper to approximately 0.75 in. wg.