

Installation Instructions

NOTE: Read the entire instruction manual before starting the installation.

TABLE OF CONTENTS

	PAGE
SAFETY CONSIDERATIONS	1
INTRODUCTION	1
DESCRIPTION AND USAGE	1
INSTALLATION	5
COMMONLY ASKED QUESTIONS	7
MAINTENANCE OF CELLS	8
TROUBLESHOOTING	8
PARTS LIST	11

SAFETY CONSIDERATIONS

Improper installation, adjustment, alteration, service, maintenance, or use can cause explosion, fire, electrical shock, or other conditions which may cause death, personal injury, or property damage. Consult a qualified installer, service agency, or your distributor or branch for information or assistance. The qualified installer or agency must use factory-authorized kits or accessories when modifying this product. Refer to the individual instructions packaged with the kits or accessories when installing.

Follow all safety codes. Wear safety glasses, protective clothing, and work gloves. Have a fire extinguisher available. Read these instructions thoroughly and follow all warnings or cautions included in literature and attached to the unit. Consult local building codes, the current editions of the National Fuel Gas Code (NFGC) NFPA 54/ANSI Z223.1, and the National Electrical Code (NEC) NFPA 70.

In Canada refer to the current editions of the National Standards of Canada CAN/CSA-B149.1 and .2 Natural Gas and Propane Installation Codes, and Canadian Electrical Code CSA C22.1.

Recognize safety information. When you see this symbol  on the unit and in instructions or manuals, be alert to the potential for personal injury. Understand the signal words **DANGER**, **WARNING**, **CAUTION**, and **NOTE**. These words are used with the safety-alert symbol. **DANGER** identifies the most serious hazards which **will** result in severe personal injury or death. **WARNING** signifies hazards which **could** result in personal injury or death. **CAUTION** is used to identify unsafe practices which **may** result in minor personal injury or product and property damage. **NOTE** is used to highlight suggestions which **will** result in enhanced installation, reliability, or operation.

INTRODUCTION

These instructions cover the installation, operation and maintenance of an EACB Electronic Air Cleaner.

This electronic air cleaner is technically known as a two-stage electrostatic precipitator. The air cleaner is designed to remove airborne particulates, including dust, dirt, smoke, pollen, virus, spores, bacteria and mold, from indoor air. Air movement through the unit is provided by the heating, air conditioning or ventilating system blower. As dirty air enters the air cleaner, the air passes through a metal mesh prefilter. The prefilter prevents lint, pet hair and other large particulates from entering the air cleaner. It is important that these filters be in place to prevent excessive dirt loading of the air cleaner collector cells. These filters extend the time between maintenance of the air cleaner collector cells. This allows the ionizing-collector cells to provide clean air for a longer period between washings. The prefiltered air then passes through a two-stage Electronic Air Cleaner. In the first stage, all airborne particulate, even submicron size, are electronically charged (positive) as they pass through the ionizer. The ionizer field is set up by a corona discharge emanating from the fine, tightly strung wires suspended between two adjacent flat plates. In the second stage, the charged particulate passes through an intense electrical field established between alternately charged and grounded parallel collector plates. Here, the positively charged particulate is attracted to the negatively ground plates and removed from the air stream.

DESCRIPTION AND USAGE

Unit Specifications

This air cleaner is easy to install, operate, and maintain. See Fig. 1 for EACB assembly. See Table 1 and Fig. 2 for unit specifications.

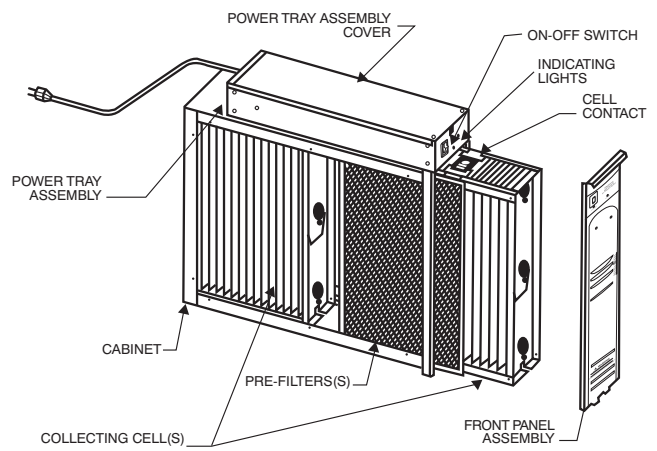

C04006

Fig. 1 - Unit Assembly

Table 1 – Unit Specifications

MODEL NO.	EACBA---0014	EACBA---0020	EACBA---1614	EACBA---2020	EACBB---2020
Airflow Sensor Factory Installed	YES	YES	YES	YES	YES
Electrical Input	120v, 60Hz, 1 PH	120v, 60Hz, 1 PH	120v, 60Hz, 1 PH	120v, 60Hz, 1 PH	240v, 60Hz, 1 PH
Electrical Power Cord	6' / 1.8 m Length	6' / 1.8 m Length	6' / 1.8 m Length	6' / 1.8 m Length	6' / 1.8 m Length
Maximum Rated Airflow	1400 CFM (2380 m3/hr)	2000 CFM (3400 m3/hr)	1350 CFM (2282 m3/hr)	1600–2000 CFM* (2720–3400 m3/hr)	1600–2000 CFM* (2720–3400 m3/hr)
Maximum Pressure Drop	.11 in. w.g. @ 1400 CFM	.14 in. w.g. @ 2000 CFM	.14 in. w.g. @ 1350 CFM	.11–.22 in. w.g. @ 1600–2000 CFM*	.11–.22 in. w.g. @ 1600–2000 CFM*
Cell Weight (2 per unit)	10 lbs each (4.54 kg)	12 lbs each (5.45 kg)	7 lbs each (3.2 kg)	9 lbs each (4.08 kg)	9 lbs each (4.08 kg)
Unit Weight	32 lbs (14.6 kg)	36 lbs (16.4 kg)	29 lbs (13.2 kg)	30 lbs (13.6 kg)	30 lbs (13.6 kg)
Maximum Power Consumption	40 Watts	48 Watts	40 Watts	40 Watts	40 Watts
Electrical output	2.5 mADC 6200 kVDC	3.2 mADC 6200 kVDC	2.5 mADC 6200 kVDC	2.5 mADC 6200 kVDC	2.5 mADC 6200 kVDC
Approvals/Certifications	c UL us	c UL us	c UL us	c UL us	c UL us
Dimensions	20 x 7–1/4 x 25	24–1/2 x 7–1/4 x 25	20 x 7–1/4 x 21–1/4	24–1/2 x 7–1/4 x 21–3/8	24–1/2 x 7–1/4 x 21–3/8

* Pressure drop at 2000 CFM. Filter efficiency is less than peak at this higher airflow. Refer to the Efficiency and Pressure Drop Performance chart below for different applications.

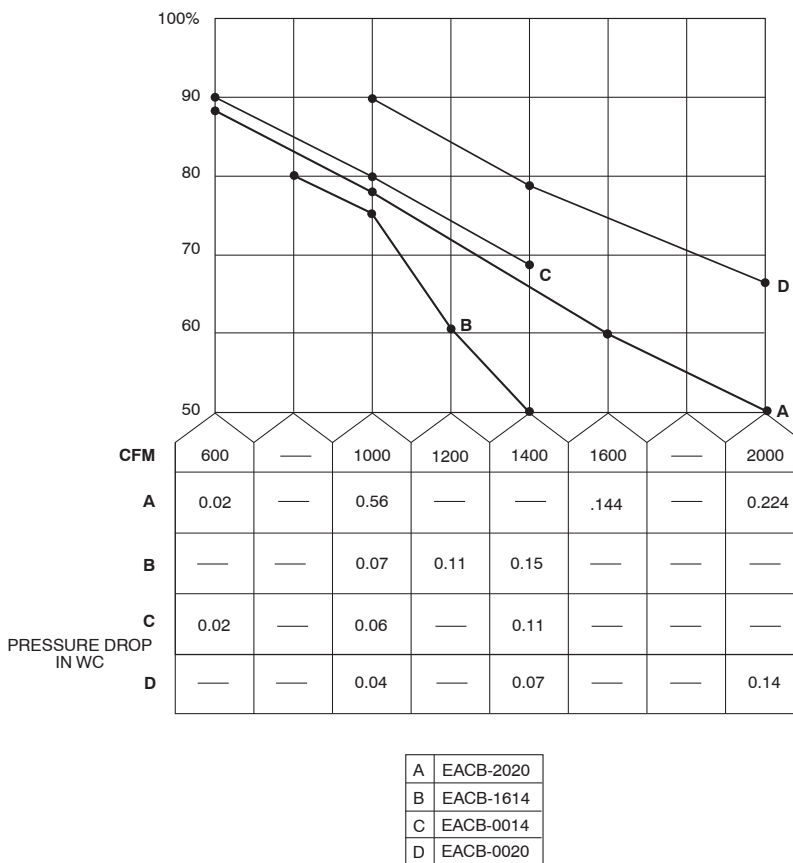

Fig. 2 - Efficiency and Pressure Drop Performance

A06014

The EACB basic components are:

Cabinet

Mounts to existing ductwork; houses the ionizing-collecting cells and prefilters.

Ionizing-Collector Cells

Collect the dust, dirt, and other particulates in the air. They contain the ionizing and collecting sections. The cells must be installed with ionizing wires on the air intake side. A spring contact is located on the top of each cell and must be in position to make

contact with the contact board assemblies on the bottom of the power tray assembly.

Prefilters

Trap large particulates before it enters the ionizing-collector cells.

Power Tray Assembly

Contains the indicating light, solid state power supply, contact boards and electrical controls including ON/OFF switch, airflow sensor and safety interlock switch. A power cord at the rear of the tray allows the unit to be connected to a standard 120-v or 240-v outlet (see voltage of your EACB unit). A wiring compartment is

EACB

provided at the rear of the tray allowing the option to permanently wire the unit directly to a furnace control.

AirFlow Sensor (AFS)

This part controls the operation of the unit by sensing the movement of air within the duct. This helps to reduce power usage.

How to Identify Which Air Cleaner Model You Own

The model number and serial number for your Electronic Air Cleaner can be found on the data label located on the inside of the access door.

Facts You Should Know About Your New Electronic Air Cleaner

Dusting and “White Dust”

Your new Electronic Air Cleaner will efficiently clean and filter your household air. Unfortunately, it will not eliminate the need for regular dusting of your furniture and belongings. Due to the design of all duct-mounted air cleaners, they can only clean the air that reaches the air cleaner. Therefore, if the particulates are not being carried to the air cleaner in the air stream, the air cleaner cannot remove them from your home. Occasionally a “white dust” may be noticed in bedrooms or newly furnished rooms. This is mainly composed of lint which, because it is heavier than other particulates, settles before it reaches your unit. This “white dust” is not mixed with airborne dirt particles, therefore, it is clean and has no staining or soiling properties. However, running the furnace blower continuously, day and night, will help reduce this from occurring.

Ozone

Under normal operating conditions all Electronic Air Cleaners produce minute quantities of ozone as an incidental by-product. In fact, all electronic products, such as televisions, cordless phones and refrigerators, produce some amount of ozone. The average homeowner can detect the smell of ozone concentrations as low as 25 to 100 ppb (parts per billion). The design of this unit has been tested and ozone production is approximately half of the published permissible limits established by the Environmental Protection Agency. These limits recommend that the concentration of indoor ozone not exceed 50 ppb. Ozone is not harmful in these concentrations. In fact, the ozone level in major cities can sometimes reach as high as 100 ppb on a summer day. The addition of optional charcoal after-filters can help reduce this. Normally, a new unit will produce more ozone than one that has been in operation for several weeks. This is due to sharp corners or manufacturing burrs on the ionizing-collecting cell(s) and is normal. As the Electronic Air Cleaner arcs and zaps, the voltage is vaporizing these areas and tends to round them off. This is part of the breaking-in period of ownership and the issue is self-correcting. Also, high-altitude locations can be more susceptible to noticing the presence of ozone. An ionizing-collecting cell that has been damaged or bent (the designed spacing between electrically charged and ground components has been decreased) may also produce an abnormal amount of ozone.

How the Airflow Sensor (AFS) Works

Electronic AFS (see Fig. 3) was designed to provide an efficient and reliable method of controlling the operation of the air cleaner when the dealer is unable to wire the unit directly into the furnace blower. The electronic AFS is now integrated into the power supply circuitry and utilizes a thermistor that heats up to approximately 130°F (54°C). The AFS then stabilizes at this temperature and when the furnace blower turns on and air flows through the ductwork, the same vacuum effect pulls cooler air over the hot surface. This air movement cools down the thermistor and

this cooling down effect allows the electronic AFS to understand that the furnace blower is moving air and the Electronic Air Cleaner must turn on to provide air cleaning.



Fig. 3 - Airflow Sensor

A05029

If the air cleaner is installed in a location that is dusty and dirty, the sensor on the AFS can become coated with dirt and lint. This coating can insulate the AFS and keep it from operating properly. To clean the thermistor, turn unit off and allow thermistor to cool, then take a cotton swab dipped in rubbing alcohol and carefully insert it into the hole located on the right hand side of the power pack assembly (when facing the unit). The hole is 3/16” (5 mm) in diameter and is located on the front of the power tray assembly. Carefully twirl the cotton swab between your fingers, making sure the tip is lightly in contact with the coated bead, cleaning this coating from the thermistor. If airflow sensor is bypassed on the circuit board, the Air Cleaner will run at all times when power is applied (see Fig. 4).

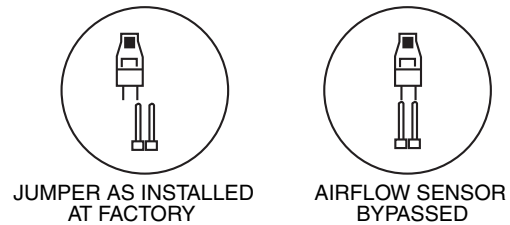

Fig. 4 - JP9 Prongs

A05030

Outdoor Air

When outdoor air is added to the return air duct, sufficient heat should be added to maintain the return air temperature at 55°F (13°C) intermittent or 60°F (16°C) continuous. Lower air temperatures can cause premature heat exchanger or ionizer wire failures.

Sheet Metal Installations

⚠ CAUTION

CUT HAZARD

Failure to follow this caution may result in personal injury.

Sheet metal parts may have sharp edges or burrs. Use care and wear appropriate protective clothing and gloves when handling these parts.

The Electronic Air Cleaner is adaptable to all new or existing residential forced air furnace and cooling systems.

Transitions

If the air duct does not fit the air cleaner cabinet opening, gradual transitions (see Fig. 5) are recommended to reduce air turbulence through the air cleaner and maximize efficiency. Not more than 20° (about 4” / 102 mm per running foot / 305 mm) of expansion should be used on each side of the transition fitting.

EACB

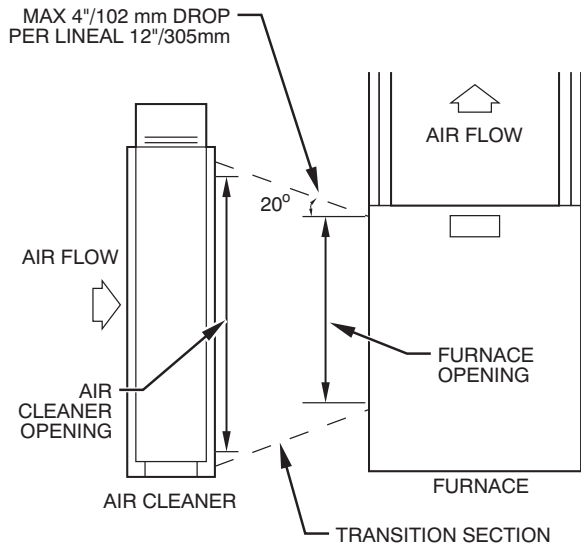

Fig. 5 - Transition to Unit

A07682

Turning Vanes

If the air cleaner is installed adjacent to a 90° duct elbow, add turning vanes (see Fig. 6) inside the duct to improve air distribution across the face of the air cleaner. Failure to follow this recommendation can reduce the efficiency of the Electronic Air Cleaner.

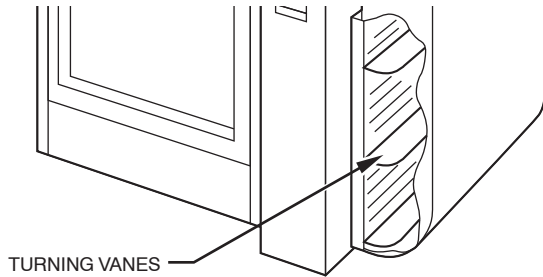

Fig. 6 - Turning Vanes

C02038

Select Location for Air Cleaner

Remember to select a location that is readily accessible for periodic inspection and cleaning of this air cleaner. Allow a minimum of

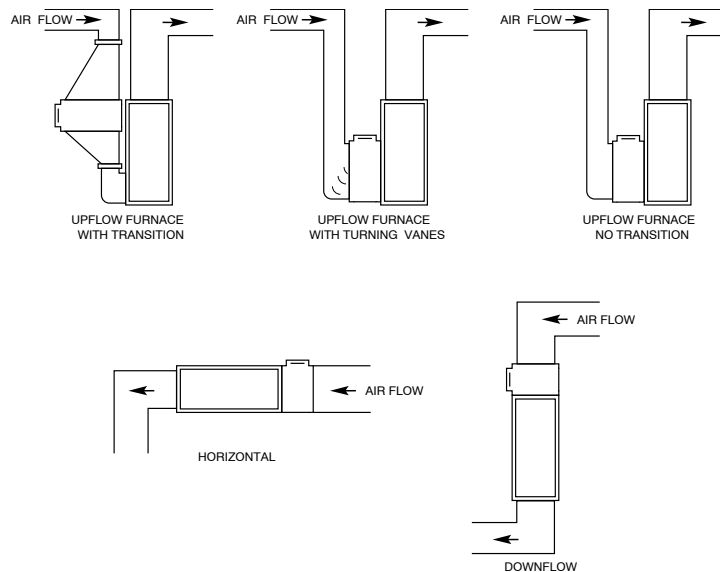

Fig. 7 - Typical Installations

A98179

24" (610 mm) clearance in front and 12" (305 mm) clearance above the air cleaner for component removal and service space.

Planning the Installation

Application

Air cleaners are used in forced air heating cooling and ventilating systems. The air cleaner should be installed in the system so that all the system air is circulated through the air cleaner. The air cleaner will only remove the airborne contaminants delivered to it. Maximum performance is obtained when the system blower is set for continuous operation.

Installation Requirements

The best location for the air cleaner is in the return air duct next to the blower compartment. In this location, the blower motor and cooling coils will be kept clean.

⚠ CAUTION

UNIT OPERATION AND SAFETY HAZARD

Failure to follow this caution may result in reduced airflow and potential operating problems.

Do not install the air cleaner in the discharge air duct.

Before installing the air cleaner, consider the application and type of HVAC system present. See Fig. 7 for the most common types. If a transition between the ductwork and air cleaner is required, refer to section entitled Transitions and Fig. 5. The unit must be readily accessible for periodic inspection and cleaning of the prefilters and electronic cells to maintain maximum efficiency and trouble-free operation.

Air Conditioning

The air cleaner should be installed upstream of the cooling coil. This will keep the coil clean and reduce air conditioning coil maintenance. Improved cooling efficiency is the result and directly affects energy costs. A clean coil will reduce utility costs.

Humidifiers

An evaporative humidifier can be mounted upstream of the air cleaner. It is best to install an atomizing humidifier downstream of the air cleaner because hard water salt deposits and water droplets may damage the air cleaner.

If an atomizing humidifier must be mounted upstream of this air cleaner:

1. Mount it as far upstream as possible (recommended 6’/2m minimum).
2. Install a standard disposable furnace filter between the humidifier and the air cleaner to trap water droplets and hard water salts.
3. Clean the air cleaner more frequently to prevent a hard water salt buildup.

Direction of Airflow Through the Air Cleaner

This air cleaner is set up for left to right airflow when you are facing the access door. For right to left airflow, follow these directions:

1. Remove the prefilter(s) and cells from the cabinet. A plastic positioning spacer is located inside the bottom of the cabinet. This spacer (see Fig. 8) is secured to the cabinet using a #6-32 round head Phillips drive thread cutting screw to assure installation of the cells in the proper position with respect to airflow.
2. Remove the screw and reposition the spacer in the alternate hole at the bottom of the cabinet.

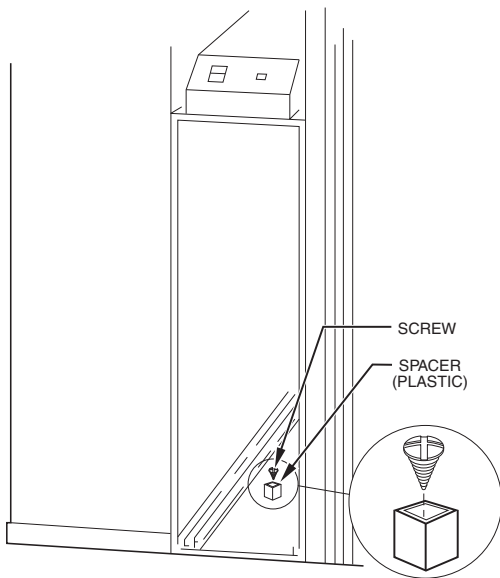

A05298

Fig. 8 - Plastic Positioning Spacer

3. Replace the screw to insure the plastic spacer is not accidentally knocked out of place during normal maintenance. It must be installed in the hole provided closest to the air leaving side of the cabinet. Seal the unused hole with duct tape.
4. Remove the cell handle and reattach to the opposite end of the cell. Turn cells around, replace in cabinet and replace prefilters on the air entering side. The directional arrows on the cell end plates must point in the direction of airflow.

INSTALLATION

This Electronic Air Cleaner can be installed in any position, except with the access door facing down. Fig. 7 shows examples of proper air cleaner mounting with a variety of furnace installations.

⚠ WARNING

ELECTRICAL SHOCK HAZARD

Failure to follow this warning could result in personal injury or death.

The following procedures could expose hazardous live components. Only a trained, experienced service person should install this electronic air cleaner. Before performing installation, service or maintenance operations on unit, turn off all power to unit. TAG DISCONNECT SWITCH WITH LOCKOUT TAG.

⚠ WARNING

ELECTRICAL SHOCK HAZARD

Failure to follow this warning could result in personal injury or death.

The power supply should be removed before installation. To remove the power supply, remove the two (2) screws in the top front of the cabinet. Remember to keep this hardware for reinstallation of the power supply when the air cleaner installation is complete.

EACB

Prior to installing this product:

1. Read rules and instructions carefully for safe operation. Failure to follow them could damage the product or cause a hazardous condition.
2. Check the ratings given on the product to make sure it is suitable for your application.
3. Select a location for the air cleaner.
4. Remove the old furnace filter and discard.
5. The air cleaner cannot remove existing dirt from the blower and ducts. Clean the area thoroughly before you begin.
6. Remove unit access panel, and slide the prefilters and ionizing-collecting cells out of the cabinet. Place them safely aside for later use.

NOTE: The following is a typical installation of the air cleaner on a upflow furnace. You may have to alter the installation to fit your particular application.

Installation of the EAC

⚠ WARNING

ELECTRICAL SHOCK HAZARD

Failure to follow this warning could result in personal injury or death.

The following procedures could expose hazardous live components. Only a trained, experienced service person should install this electronic air cleaner. Before performing installation, service or maintenance operations on unit, turn off all power to unit. TAG DISCONNECT SWITCH WITH LOCKOUT TAG.

1. Locate the cabinet in the cold air return duct so that all of the return air flows through the unit. If the furnace and air cleaner openings are different, use a transition.
2. Mounting holes are provided for ductwork attachment. The .140” holes (see Fig. 9) are sized for #8 sheet metal screws,

or 1/8" rivets. If the adjoining ductwork is flanged, install the screws so that the screw heads are inside the cabinet. This will prevent damage to the prefilters and optional charcoal after-filter during removal and installation after cleaning.

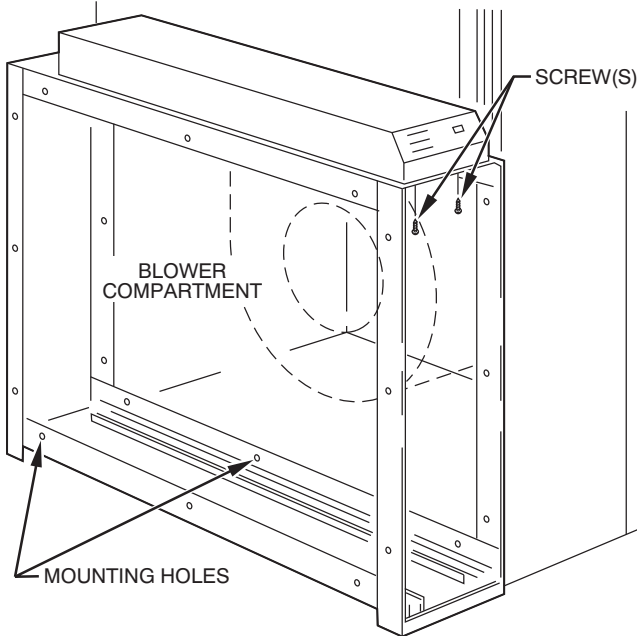

Fig. 9 - Mounting Hole Location

A07683

3. After the unit has been secured, seal seams air tight with foil tape or caulking.
4. Determine direction of airflow and make any changes necessary.
5. Install prefilters and ionizer-collector cells.
6. Reinstall power tray assembly into the cabinet.
7. Reinstall unit access panel.

ELECTRICAL INSTALLATION

⚠ WARNING

ELECTRICAL SHOCK HAZARD

Failure to follow this warning could result in personal injury or death.

The following procedures could expose hazardous live components. Only a trained, experienced service person should install this electronic air cleaner. Before performing installation, service or maintenance operations on unit, turn off all power to unit. TAG DISCONNECT SWITCH WITH LOCKOUT TAG.

The Electronic Air Cleaner is designed to take advantage of the AFS (AirFlow Sensor) integrated into the power supply. This airflow sensor will sense the air movement within the duct and turn the Electronic Air Cleaner on and off accordingly.

Wiring Procedure

This air cleaner is powered by plugging the power cord into an acceptable receptacle (see Fig. 10).

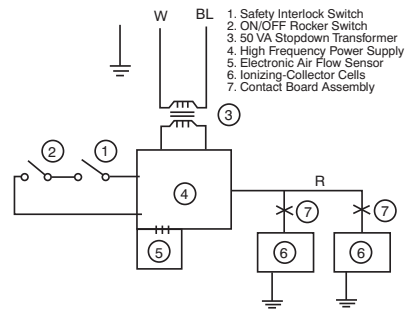

Fig. 10 - Typical Wiring Diagram

A07814

1. Turn air cleaner OFF using ON/OFF rocker switch located on front panel.
2. Plug power cord into acceptable receptacle.
3. Replace the unit door to the front of the air cleaner.
4. Air cleaner will now operate when door is in place, ON/OFF rocker switch is in the ON position and input voltage is present to unit.

Furnace Application

AFS will turn unit on when airflow is sensed. Air cleaner should only operate when blower motor is running. The unit will also operate normally if the air cleaner is hard wired directly to the furnace control board. To bypass the airflow sensor, install the jumper on the JP9 prongs as shown in Fig. 4. Now the air cleaner will run at all times when power is applied.

⚠ CAUTION

UNIT DAMAGE HAZARD

Failure to follow this caution may result in damage to this unit.

This unit cannot be powered directly from blower motor leads. Back EMF (electromagnetic field) voltages can exceed 190 volts for 120v motors or possibly double with 240v fan coil motors.

Fan Coil Application of 2020 Model (240v)

One Model 2020 is a 240v power supply model designed to match your fan coil. AFS will turn unit on when airflow is sensed. Air cleaner should only operate when blower motor is running.

⚠ CAUTION

UNIT DAMAGE HAZARD

Failure to follow this caution may result in damage to this unit.

This unit cannot be powered directly from blower motor leads. Back EMF (electromagnetic field) voltages can exceed 190 volts for 120v motors or possibly double with 240v fan coil motors.

To install this model with a 240v fan coil:

1. Turn air cleaner OFF using ON/OFF rocker switch located on front panel.
2. Plug power cord into acceptable receptacle.
3. Replace the unit door to the front of the air cleaner.
4. Air cleaner will now operate when door is in place, ON/OFF rocker switch is in the ON position and input voltage is present to unit.

System Checkout

WARNING

ELECTRICAL SHOCK HAZARD

Failure to follow this warning could result in personal injury or death.

The following procedures could expose hazardous live components. Only a trained, experienced service person should install this electronic air cleaner. Before performing installation, service or maintenance operations on unit, turn off all power to unit. **TAG DISCONNECT SWITCH WITH LOCKOUT TAG.**

1. The HVAC system blower should be turned OFF.
2. Switch the ON/OFF rocker switch to the ON position. The bright red segment of the rocker switch should be visible.
3. Inspect both the Green INPUT POWER light and the Red CELL ENERGIZED light:
 - With the AFS installed, the Red CELL ENERGIZED light should go out in approximately 20 to 60 seconds. This is the normal time for the electronic airflow sensor to complete its stabilization period. Both lights will come back on when the HVAC system blower begins to operate. See the section entitled HOW THE AIRFLOW SENSOR WORKS for more information.
4. Wait approximately one (1) minute and turn the HVAC system blower ON. Most thermostats have a setting that will allow you to run the fan manually. If not, then set the thermostat so that either hot or cold air begins to flow through the ductwork.
5. The Green INPUT POWER light and Red CELL ENERGIZED light should come on.
6. Check to make sure that the Red CELL ENERGIZED light goes out when the following conditions occur:
 - Cell access panel is removed
 - Rocker switch is switched to the OFF position
 - HVAC system blower is not running

COMMONLY ASKED QUESTIONS

Q. Why isn't my air cleaner cleaning my air?

A. The air cleaner is most likely working just like it was designed. However, many factors can affect the performance of the unit. Are cold air registers located in the ceiling? If so, it will be difficult for the airflow to carry heavier particulates to the air cleaner. If the dirt doesn't get to the air cleaner, it can't be removed from the air. Are both the Red and Green lights illuminated? If not, then the unit may be in need of servicing. Contact your local HVAC dealer for assistance.

Q. It still isn't cleaning my air the way I want it to. What can I do?

A. We recommend that you run the blower continuously so that the air movement will carry the dirt to the air cleaner. Unfortunately, there will always be some dirt that is left behind on

the appliances, furniture, etc. Regular dusting is recommended to stir up these pockets of dust so that they can enter the airstream and be removed by the Electronic Air Cleaner.

Q. When I turn on my Electronic Air Cleaner, the lights come on for a couple of seconds and then turn off. The air cleaner isn't working!

A. The air cleaner is fine as long as both the Red and Green lights are coming on. Try turning the HVAC blower OFF and then turning the Electronic Air Cleaner on. This should solve the problem.

Q. What is the zapping noise I am hearing from my unit? Should I be concerned?

A. The zapping or popping noise that you are hearing is the sound of larger particles being vaporized by the ionizing-collector cell. This is normal and is no cause for alarm. As your HVAC system blower moves the air through the ductwork and allows the Electronic Air Cleaner to clean the air, the noise will diminish. However, there will always be instances when larger particles enter the ionizing-collector cell.

Q. Should I hear this zapping noise all the time?

A. All Electronic Air Cleaners will occasionally zap or pop as larger particles pass through the ionizing-collector cells. However, if the sound is constant or is repetitive in nature, then a large particle may have become lodged in the ionizing-collector cells and they may require cleaning. If cleaning the ionizing-collector cells does not stop the noise and there are no large particles trapped in the ionizing-collector cells, then the cause could be a broken/loose ionizing wire, bent collector plate or other mechanical reason. Please contact your local HVAC dealer for assistance.

Q. What if I no longer hear any popping or zapping noises coming from my unit? Is it still cleaning the air?

A. If the zapping noises stop and the air cleaner is not in need of servicing, then one of two situations has occurred. First, the Electronic Air Cleaner has successfully removed all larger particles from the air and is cleaning microscopic particles which do not cause the zapping noise. Second, the blower and/or HVAC system is not running and air is not flowing through the ductwork. The Electronic Air Cleaner cannot remove particles if the air stream is not moving.

Q. I lost power to my home during a storm. Should I worry about the Electronic Air Cleaner?

A. The most common problem associated with power outages is the unit will not turn on properly after power is restored. If the Red and Green light come on for a couple of seconds and then go off, the unit is OK. Just turn the HVAC blower off, turn the unit ON and then turn the blower back on. If the Red and/or Green light does NOT come on after a storm, the power supply in the Electronic Air Cleaner may be short circuited. Contact a local HVAC contractor for further information.

Q. My installer told me to keep the HVAC system blower running all the time, but I don't want to increase my power bill. What should I do?

A. It is recommended that you keep your HVAC system blower running all the time to achieve the maximum air cleaning efficiency. This will allow the Electronic Air Cleaner to do what it is designed to do, which is clean the air. Remember that if the air does not reach the air cleaner, it cannot be cleaned. On average, your Electronic Air Cleaner will use the same amount of electricity as a 55 watt light bulb. The energy usage of the HVAC system blower will depend on the age of your system, energy costs in your regional location and other variables. The best solution is to try running the HVAC system blower in continuous mode for a month or two to estimate your annual energy costs and base your final decision on what you feel most comfortable with.

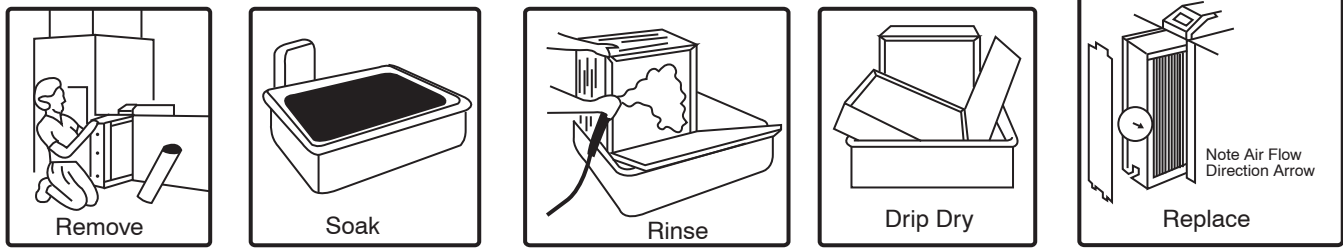

C02035

Fig. 11 - Typical Call and Prefilter Cleaning

MAINTENANCE OF CELLS

Washing Cells and Prefilters

Regular washing is necessary to ensure proper performance (see Fig. 11). A thorough washing once every two months will be adequate for most installations. More frequent washing (once a month) may be necessary on some installations (new homes for example) where there is new carpeting, plaster dust, or excessive cigarette smoke.

To remove cells and prefilter

1. Push air cleaner switch to the OFF position. Wait 15 seconds. Open door access panel.
2. Carefully remove cells and prefilter(s) and set aside in a safe place.
3. Do not drop the ionizing-collector cell. This could cause damage to the cell plates or ionizing wires and cause excessive arcing and noise.

To wash cells and prefilter(s)

To wash cells and prefilter(s) We suggest that you follow the instructions below to properly and thoroughly clean your collector cells.

1. Place enough hot water in a utility tub to cover the first cell. Dissolve 2 to 4 oz. of granulated automatic dishwasher detergent (not laundry detergent) in the water.
2. Allow the cell to soak for 30 minutes. Agitate it up and down in the solution until it appears clean and remove.
3. Repeat with second cell.
4. Agitate the prefilters up and down in the solution until they appear clean.
5. With a hose, rinse the cells and prefilters. The hose should be held about 10" (254 mm) from the cell plates and at a slight angle for better cleaning results. Be careful not to spray the ionizing wires directly with the hose. The water pressure can cause the wire to snap and break. The cell frame should be thoroughly rinsed along the edges to dislodge any trapped lint or dirt. Carefully wipe a damp cloth or sandpaper (not emery cloth) along the ionizing wires.
6. Stand cells and prefilters up to drain. Let dry two hours. You may experience a slight discoloration of the aluminum collector cells after washing. This is a normal chemical reaction and will not harm your unit or affect its performance.

To replace cells in air cleaner

1. Replace prefilter and cells in cabinet. Check that arrow on cells points in same direction as air flows through the duct (If you have to force it past the positioning screw on bottom, it is probably in the wrong position).
2. Replace access door (engage tabs on lower edge of door into slots in cabinet). Carefully close door.
3. Turn air cleaner switch to ON.

TROUBLESHOOTING

⚠ WARNING

ELECTRICAL SHOCK HAZARD

Failure to follow this warning could result in personal injury or death.

The following procedures could expose hazardous live components. Only a trained, experienced service person should install this electronic air cleaner. When the circuit has been de-energized, always discharge any residual current in the secondary with an insulated handle screwdriver. Always ground power supply and ionizing-collecting cell when bench testing. Before performing installation, service or maintenance operations on unit, turn off all power to unit. TAG DISCONNECT SWITCH WITH LOCKOUT TAG.

Recommended Service Tools

1. Screwdriver, 8" common with insulated handle (plastic)
2. Screwdrivers Phillips #1 and #2 with plastic insulated handles
3. Needle nose pliers
4. Multimeter
5. High voltage probe

Indication of Electrical Trouble

The air cleaner is equipped with a Red CELL ENERGIZED light for indicating proper unit operation. When the unit is in normal operation (with the HVAC system fan running, access door in place and rocker switch in the ON position) and the Red CELL ENERGIZED light is not lit, the problem is a shorted secondary. Although failure of the indicating light itself should not be overlooked, this condition is unusual and rather remote.

Primary Circuit with Blower Operating

If there is supply line voltage at the connections and no input voltage to the power supply, the outage can be located by checking operation of the safety switch and the interconnecting wiring with a multimeter. Refer to Circuit Diagram, to check operation of the switches. Following these steps to test for proper operation of the circuit board and power supply assembly:

1. Ensure that the circuit breaker controlling the furnace blower is in the ON position and the main fuse is not open.
2. The power supply board has a built-in internal fuse to protect the 24V transformer. It can be checked visually by inspecting the fuse. If the fine wire inside the fuse is broken, this indicates a problem in the 24V circuit of the power supply board. Do NOT replace this fuse. The entire power supply board must be replaced. The purpose of the fuse is not to protect the power supply board, but to function as a troubleshooting feature of the product and to protect the transformer from damage.

3. If the fuse is NOT blown, check the ON/OFF switches and safety interlock switch for proper engagement and operation. This can be completed using a volt ohm millimeter on a scale that will measure ohms as low as 1.0. If you are using the recommended meter previously mentioned in this manual, set the meter to read 200 ohm and proceed with Steps 4 through 6.
4. Remove the fuse. Connect one lead to the test pin located directly beside the wire that connects the ON/OFF switch to the power supply board. Connect the other lead to the fuse connection closest to the front panel.
5. Turn the ON/OFF switch to the ON position and depress the safety interlock switch. The meter should have the capability of reading levels as low as 1.0 ohm.
6. If there is no reading on the meter, begin the process of elimination by disconnecting the wire from the test point and connecting it to the terminal with the blue wire located on the safety interlock switch. Depress the safety interlock switch. If the reading on the meter is greater than 1.0 ohm, the safety interlock switch is defective and must be replaced. If the reading on the meter is less than 1.0 ohm, the ON/OFF switch is defective and must be replaced.

Ionizing-Collecting Cell

Secondary Circuit

The cell is electrically energized through a contact terminal located at the top center of the cell. The ionizing wires and alternating collector plates are electrically charged while the interleaving plates are grounded. If the space between the charged and grounded plates is bridged with conductive or semi-conductive material, a short circuit develops. The bridging or short may be caused by damaged plates, or foreign material lodged between/on the components.

Since the cell should be periodically removed from the unit to wash away collected dirt, it is susceptible to physical damage. The cell also contains the ionizing wires which, due to their function, have been designed with minimal structural support and are susceptible to breakage. However, trouble related to a shorted collector cell is readily shown by the Red CELL ENERGIZED light and can be quickly isolated by a simple procedure.

To determine if a short exists in one or both of the collector cells, turn the Electronic Air Cleaner OFF and remove both electronic cells from the cabinet. Shut the door and repower the unit. If the Red CELL ENERGIZED light comes on, an electrical short exists in one or both of the electronic cells. Replace the cells in the unit, one at a time, to determine which cell is shorted. Most troubles in the cell can be visually detected and corrected.

NOTE: The ionizer collector cells are not designed for field repair. Ionizing wires and insulators can be field replaced. It is not recommended that you attempt to replace other cell components (i.e. Collector plates, end plates, ionizer supports).

Replacing the Ionizing Wires

Ionizing wire breakage is minimal because of the constant tension design and fixed location of the ionizing wire supports. When an ionizing wire breaks, the efficiency of the Electronic Air Cleaner will decrease slightly. However, the unit will continue to operate with broken ionizing wires as long as the broken wires have not caused a short circuit of the unit. Remove all loose and broken wires as soon as they are identified. Although the replacement of the ionizing wires can be attempted by a homeowner, it is recommended that you should contact a qualified HVAC contractor for replacement parts and/or servicing.

Wires are supplied in a coiled spring configuration, with a clinch nut on each end of the wire. Replacement requires a pair of needle nose pliers. Exercise caution in removing any broken wires in the collector cell. This will prevent accidental shorting of the cell and reduce the need for further maintenance. Use the following procedure when replacing an ionizing wire.

1. Ensure that all power to the Electronic Air Cleaner is OFF, remove the access door and remove the ionizing-collector cells from the unit.
2. Carefully remove all remains of the broken wire.
3. Grip the new wire at each end of the wire with your thumb and index finger. While stretching the wire to approximately 6" (152 mm) allow one end of the wire to uncoil between your thumb and index finger.
4. Place one end of the wire in the slot of the stainless steel support on the collector cell from the front of the cell. This support is partially covered by the cell brace in front of the support.
5. Grip the other end of the ionizing wire with needle nose pliers and insert the terminated end of the wire into the slot on the support bar of the opposite end of the collector cell.
6. The wire should be tight enough to be self supporting and remain suspended between the two support slots in the support bar.

EACB

 **WARNING**

ELECTRICAL SHOCK HAZARD

Failure to follow this warning could result in personal injury or death.

The following procedures could expose hazardous live components. Only a trained, experienced service person should install this electronic air cleaner. Before performing installation, service or maintenance operations on unit, turn off all power to unit. TAG DISCONNECT SWITCH WITH LOCKOUT TAG.

AFS Troubleshooting

1. Make sure the furnace blower is not operating, the rocker switch is OFF, and the circuit breaker is turned OFF or the cord is disconnected.
2. Remove the access door.
3. Remove power tray assembly.
4. Locate the AFS. It is the circuit board with a small gray disc connected to the circuit board by two (2) silver wires. Carefully bend the thermistor so that it is located in the center of the opening and approximately 1/8" (3 mm) from the inside edge of the power pack assembly.
5. Reinstall the power tray assembly and access door.

High Altitude Operation

Because the air is less dense at higher altitudes, there is a possibility of nuisance arcing. The homeowner can quickly and easily correct this condition.

1. Turn the unit OFF. Turn off circuit breaker or disconnect the power cord.
2. Remove the two screws that secure the cover to the power tray and remove it from the unit. (The entire power supply tray may be removed from the cabinet by removing two screws from inside cabinet.) Do not lose these screws.

3. Locate the jumper terminal (see 12).

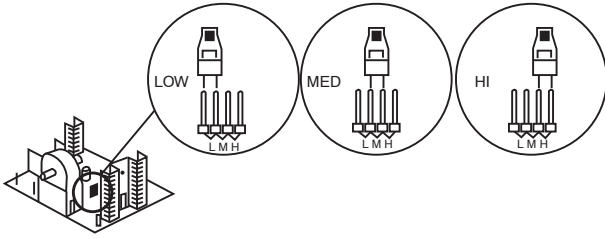

Fig. 12 - Jumper Terminal Adjustment

C02036

4. With a pair of needle nose pliers, carefully adjust the jumper settings from HIGH to MED. Ensure that the jumper is firmly seated in the terminal.
5. Replace the power tray cover and secure it with the two screws.
6. Replace the access door and turn the unit ON.

This procedure will slightly reduce the output voltage, minimize arcing, and reduce ozone production. If the condition does not improve, repeat the above procedure and move the jumper setting from MED to LOW. If this does not correct the situation, contact your local HVAC dealer. All Electronic Air Cleaners are produced at the factory with the jumpers set in the HIGH position. However, the output voltage may be lowered in any situation where the unit is arcing excessively or there is excessive ozone production.

Checking the Power Supply

If the output light remains out with the collector cells removed from the cabinet, the power supply is defective. Specific problems on the power tray assembly can be isolated by using a multimeter and high voltage probe to check the output voltages. To check the secondary circuit, a high voltage meter is required. See the section entitled Recommended Service Tools. To check for proper operation, it is imperative that the procedure be followed as outlined below:

1. Make sure the furnace blower is operating, the control switch is on, and input voltage is correct.
2. Remove front door assembly panel.
3. Remove power pack access cover.
4. Check the high voltage contact board assembly(s) for damage or carbon tracking.

NOTE: The cell contacts should be visually checked for corrosion, excessive dirt build up, and electrical arc tracking (carbon path from stainless steel spring to grounded metal). Clean or replace as required.

5. Make connections from the high voltage probe to the multimeter in accordance with the operator's manual. The meter should be set for reading DC voltage on the 20 volt full scale.
6. Attach the high voltage probe ground lead to the cabinet. While depressing the safety switch lever, touch the ionizer

wire support bar with end of the high voltage probe. The meter reading should be 6.2 kVDC \pm .2 kVDC.

⚠ WARNING

ELECTRICAL SHOCK HAZARD

Failure to follow this warning could result in personal injury or death.

The following procedures could expose hazardous live components. Only a trained, experienced service person should install this electronic air cleaner. Before performing installation, service or maintenance operations on unit, turn off all power to unit. TAG DISCONNECT SWITCH WITH LOCKOUT TAG.

7. If no voltage is measured, remove the first cell and check the second cell. The meter should read 6.2 kVDC \pm .2 kVDC.
8. If proper voltage is measured, the first cell is shorted.
9. If no voltage is present, remove the second cell. Install cell number one and measure voltage as described above. If voltage is present, the second cell, which is now out of the cabinet, is shorted.
10. If no voltage is present, remove both cells and measure the power supply output. While depressing the safety switch, touch the end of the high voltage probe (see Fig. 13) to either the front or rear contact board assembly. The meter should read 6.2 kVDC or higher.
11. If no voltage is present, check the power supply. Set the multimeter for reading AC voltage at 200 volt full scale and attach meter test leads.
12. While depressing the safety lever, touch the two transformer output lead junctions to the power supply board with the meter leads and read the meter.
13. If there is no output voltage from 24 volt transformer, replace the 24 volt transformer and power supply board.

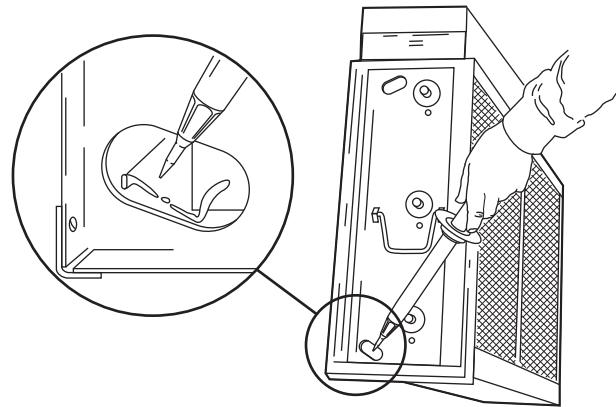
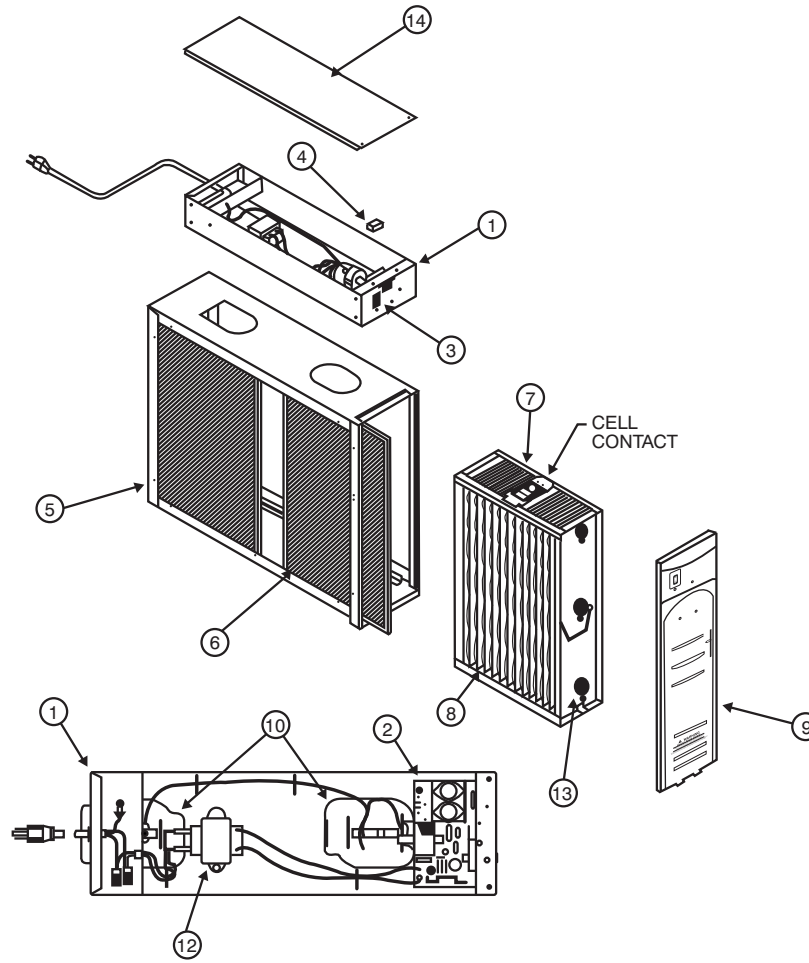

Fig. 13 - High Voltage Operation Check
(Ionizer Wire Support Bar)

A97171

PARTS LIST



EACB

A09624

PARTS LIST	
Reference Number	Description
1	Power Tray Assembly
2	High Frequency Power Supply
3	ON/OFF Switch
4	Interlock Switch
5	Cabinet Assembly
6	Prefilter (2 required)
7	Cell, Ionizing – Collecting
8	Ionizing Wire Assembly
9	Front Panel Assembly
10	Contact Board Assembly (2 required)
11	Charcoal Filter (optional, not shown)
12 (120v model)	Stepdown Transformer 120v to 24v
12 (240v model)	Stepdown Transformer 240v to 24v
13	Insulator
14	Power Tray Cover

Fig. 14 - Unit Parts Description

TROUBLESHOOTING THE DUCT MOUNT ELECTRONIC AIR CLEANER

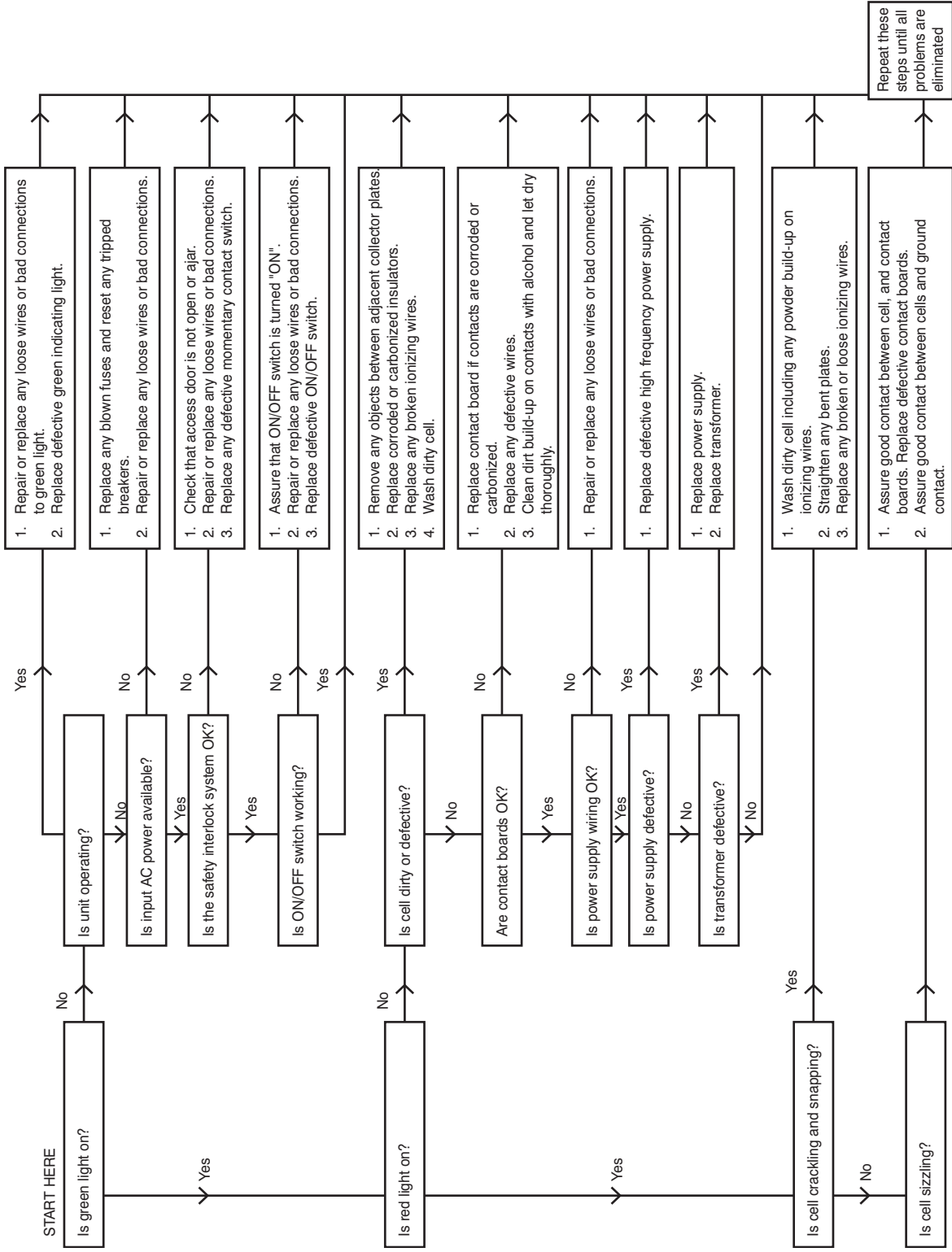

Limited Warranty for Electronic Air Cleaner

FOR WARRANTY SERVICE OR REPAIR:

Contact the installer. You may find the installer's name on the equipment or in your Owner's Packet.

For help, contact: CAC / BDP, Consumer Relations, P.O. Box 4808, Syracuse, New York 13221, Phone 1-800-227-7437

PRODUCT REGISTRATION: You can register your product online at www.cac-bdp.com.

Model No. _____ Unit Serial No. _____
 Date of Installation _____ Installed by _____
 Name of Owner _____ Address of Installation _____

CAC / BDP (hereinafter "Company") warrants this product against failure due to defect in materials or workmanship under normal use and maintenance as follows. All warranty periods begin on the date of original installation. If a part fails due to defect during the applicable warranty period Company will provide a new or remanufactured part, at Company's option, to replace the failed defective part at no charge for the part. Alternatively, and at its option, the Company will allow a credit in the amount of the then factory selling price for a new equivalent part toward the retail purchase price of a new Company product. Except as otherwise stated herein, those are Company's exclusive obligations under this warranty for a product failure. This limited warranty is subject to all provisions, conditions, limitations and exclusions listed below and on the reverse (if any) of this document.

OWNER-OCCUPIED, RESIDENTIAL APPLICATIONS

This warranty is to the original purchasing owner and is transferable only to the extent and as stated in the Warranty Conditions and below. The warranty period in years, depending on the part and the claimant, is as shown in the chart below.

Product	Limited Warranty (Years)	
	Original Owner	Subsequent Owner
EACB Electronic Air Cleaner	10* (or 5)	10** (or 5)

* If properly registered within 90 days, otherwise 5 years (except in California and Quebec and other jurisdictions that prohibit warranty benefits conditioned on registration, registration is not required to obtain longer warranty periods). See Warranty Conditions below.

** If properly transferred within 90 days, otherwise 5 years. See Warranty Conditions below. In California and Quebec and other jurisdictions that prohibit warranty benefits conditioned on registration, registration is not required for a transfer and all warranty periods for subsequent owners are five years from original installation.

OTHER RESIDENTIAL APPLICATIONS (Apartments, Rental Properties, etc.)
 The warranty period is five (5) years and is not transferable.

OTHER APPLICATIONS
 This warranty is non-transferable. The warranty period is one (1) year on all such applications.

LEGAL REMEDIES - The owner must notify the Company in writing, by certified or registered letter to CAC / BDP, Warranty Claims, P.O. Box 4808, Syracuse, New York 13221, of any defect or complaint with the product, stating the defect or complaint and a specific request for repair, replacement, or other correction of the product under warranty, mailed at least thirty (30) days before pursuing any legal rights or remedies.

39004DP449
 01/10



WARRANTY CONDITIONS:

1. To obtain the longer warranty periods as shown in the table under original owner, for the original purchaser, the product must be properly registered at www.cac-bdp.com within ninety (90) days of original installation. In jurisdictions where warranty terms conditioned on registration are prohibited by law, registration is not required and the longer warranty period shown will be apply.
2. Where a product is installed in a newly constructed home, the date of installation is the date the homeowner purchased the home from the builder.
3. If the date of original installation cannot be verified, then the warranty period begins ninety (90) days from the date of product manufacture (as indicated by the model and serial number). Proof of purchase may be required at time of service.
4. The remainder of the first five years of warranty is freely transferable without registration. To obtain a transfer of the longer warranty periods as shown in the table under subsequent owner, a subsequent owner must register the transfer at www.cac-bdp.com within 90 days of the change in ownership and payment of a transfer fee. Not applicable in all jurisdictions. See website for details.
5. Product must be installed properly and by a licensed HVAC technician.
6. The warranty applies only to products remaining in their original installation location.
7. Installation, use, care, and maintenance must be normal and in accordance with instructions contained in the Installation Instructions, Owner's Manual and Company's service information.
8. Defective parts must be returned to the distributor through a registered servicing dealer for credit.

LIMITATIONS OF WARRANTIES: ALL IMPLIED WARRANTIES AND/OR CONDITIONS (INCLUDING IMPLIED WARRANTIES OR CONDITIONS OF MERCHANTABILITY AND FITNESS FOR A PARTICULAR USE OR PURPOSE) ARE LIMITED TO THE DURATION OF THIS LIMITED WARRANTY. SOME STATES OR PROVINCES DO NOT ALLOW LIMITATIONS ON HOW LONG AN IMPLIED WARRANTY OR CONDITION LASTS, SO THE ABOVE MAY NOT APPLY TO YOU. THE EXPRESS WARRANTIES MADE IN THIS WARRANTY ARE EXCLUSIVE AND MAY NOT BE ALTERED, ENLARGED, OR CHANGED BY ANY DISTRIBUTOR, DEALER, OR OTHER PERSON, WHATSOEVER.

THIS WARRANTY DOES NOT COVER:

1. Labor or other costs incurred for diagnosing, repairing, removing, installing, shipping, servicing or handling of either defective parts, or replacement parts, or new units.
2. Any product purchased over the Internet.
3. Normal maintenance as outlined in the installation and servicing instructions or Owner's Manual, including filter cleaning and/or replacement and lubrication.
4. Failure, damage or repairs from faulty installation, misapplication, abuse, improper servicing, unauthorized alteration or improper operation.
5. Failure to start due to voltage conditions, blown fuses, open circuit breakers, or damages due to the inadequacy or interruption of electrical service.
6. Failure or damage due to floods, winds, fires, lightning, accidents, corrosive environments (rust, etc) or other conditions beyond the control of Company.
7. Parts not supplied or designated by Company, or damages resulting from their use.
8. Products installed outside the U.S.A. or its territories and Canada.
9. Electricity or fuel costs, or increases in electricity or fuel costs from any reason whatsoever, including additional or unusual use of supplemental electric heat.
10. Any cost to replace, refill or dispose of refrigerant, including the cost of refrigerant.
11. **ANY SPECIAL, INDIRECT OR CONSEQUENTIAL PROPERTY OR COMMERCIAL DAMAGE OF ANY NATURE WHATSOEVER.** Some states or provinces do not allow the exclusion of incidental or consequential damages, so the above limitation may not apply to you.

This Warranty gives you specific legal rights, and you may also have other rights which vary from state to state or province to province.

39004DP449
01/10