



EZXCABCR Sizes 016 and 020

High Efficiency Air Filtration System

Installation Instructions

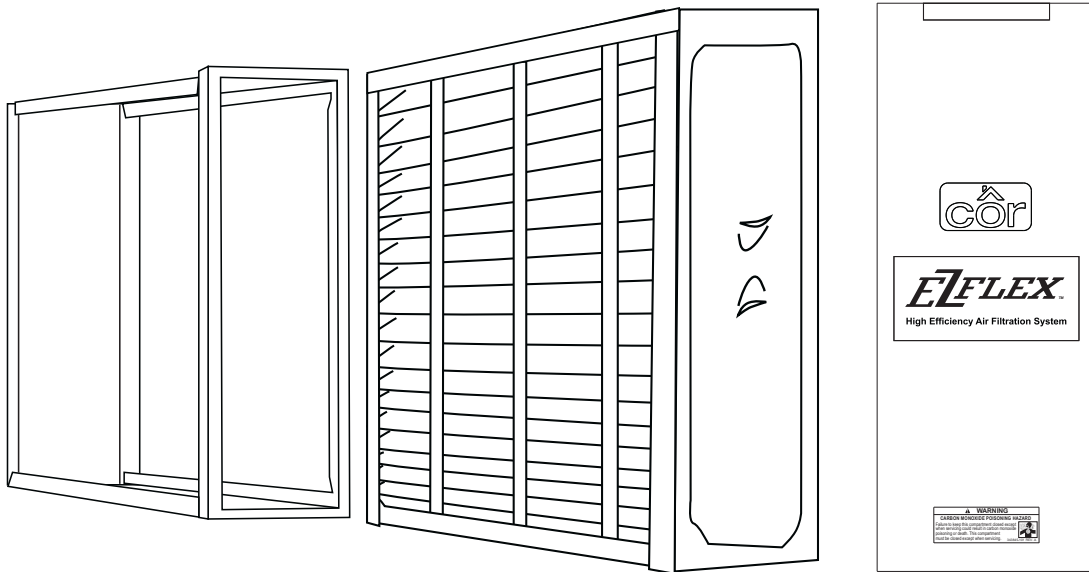

Fig. 1 - EZXCABCR

A180069CR

NOTE: Read the entire instruction manual before starting the installation.

SAFETY CONSIDERATIONS

Improper installation, adjustment, alteration, service, maintenance, or use can cause explosion, fire, electrical shock, or other conditions which may cause death, personal injury, or property damage. Consult a qualified installer, service agency, or your distributor or branch for information or assistance. The qualified installer or agency must use factory-authorized kits or accessories when modifying this product. Refer to the individual instructions packaged with the kits or accessories when installing.

Follow all safety codes. Wear safety glasses, protective clothing, and work gloves. Have a fire extinguisher available. Read these instructions thoroughly and follow all warnings or cautions included in literature and attached to the unit. Consult local building codes, the current editions of the National Fuel Gas Code (NFGC) NFPA 54/ANSI Z223.1, and the National Electrical Code (NEC) NFPA 70.

In Canada refer to the current editions of the National Standards of Canada CAN/CSA-B149.1 and .2 Natural Gas and Propane Installation Codes, and Canadian Electrical Code CSA C22.1.

Recognize safety information. When you see this symbol  on the unit and in instructions or manuals, be alert to the potential for personal injury. Understand the signal words **DANGER**, **WARNING**, **CAUTION**, and **NOTE**. These words are used with the safety-alert symbol. **DANGER** identifies the most serious hazards which will result in severe personal injury or death. **WARNING** signifies hazards which could result in personal injury

or death. **CAUTION** is used to identify unsafe practices which may result in minor personal injury or product and property damage. **NOTE** is used to highlight suggestions which will result in enhanced installation, reliability, or operation.

INTRODUCTION

These instructions cover the installation, operation and maintenance of an EZXCABCR High Efficiency Air Filtration System. See Fig. 1. Refer to Fig. 2 for a list of major components.

DESCRIPTION AND USAGE

APPLICATION

This High Efficiency Air Filtration System must be used in a forced air heating, cooling or ventilation system. This High Efficiency Air Filtration System cleaner should be installed in the system so that all the system air is circulated through this air cleaner. The High Efficiency Air Filtration System cleaner will only remove the airborne contaminants delivered to it. Maximum performance is obtained when the system blower is set for continuous operation.

INSTALLATION REQUIREMENTS

The best location for the High Efficiency Air Filtration System cleaner is in the return air duct next to the blower compartment. In this location, the blower motor and cooling coils will be kept clean. Do not install the air cleaner in the discharge (supply) air duct. Before installing this High Efficiency Air Filtration System cleaner, consider the application. If a transition is required, refer to Fig. 3 or Fig. 4. The unit must be readily accessible for periodic inspection and replacement of EZ-Flex™ filter to maintain maximum efficiency and trouble-free operation.

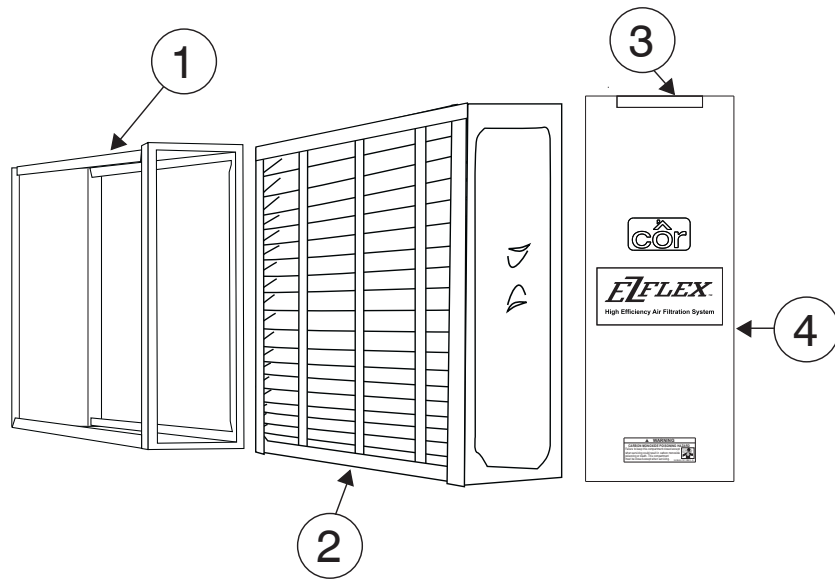

A180070CR

Fig. 2 - EZXCABCR Major Components

Table 1 – Major Components

MODELS 016 & 020	PART DESCRIPTION
1	Cabinet
2	EZ Flex Filter Media
3	Access Handle
4	Access Door

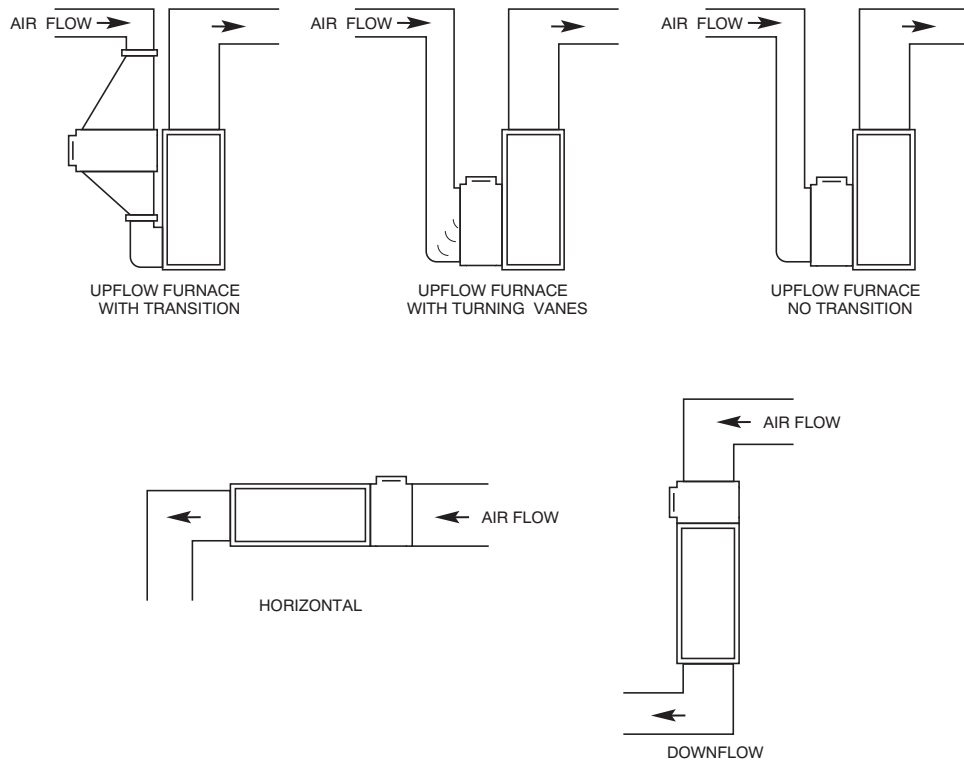

Fig. 3 - Typical Mounting Positions

A98179

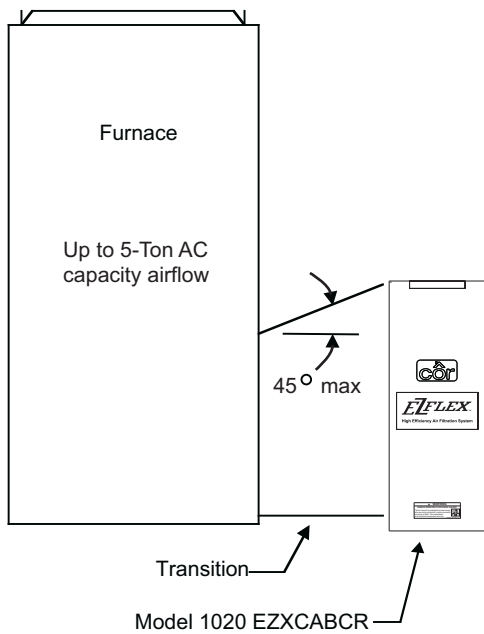

Fig. 4 - Furnace

A180071CR

AIR CONDITIONING

The High Efficiency Air cleaner should be installed upstream of the cooling coil. This will help keep the coil clean and reduce air conditioning coil maintenance. Improved cooling efficiency is the result, which directly affects energy costs. A clean coil will reduce utility costs.

IMPORTANT: Failure to replace EZ-Flex filter can cause damage to the cooling system.

TURNING VANES

If the air cleaner is installed adjacent to a 90° duct connection, add turning vanes inside the duct to improve the air distribution across the face of the high efficiency air cleaner. See Fig. 6.

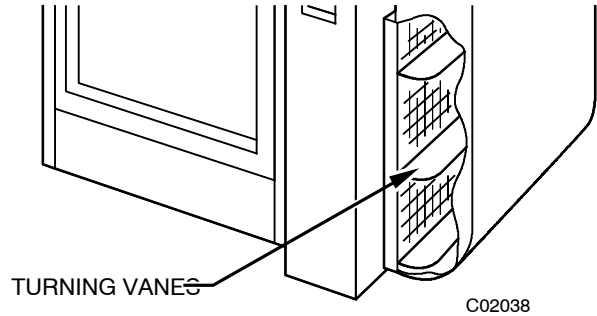

Fig. 6 - Turning Vanes

C02038

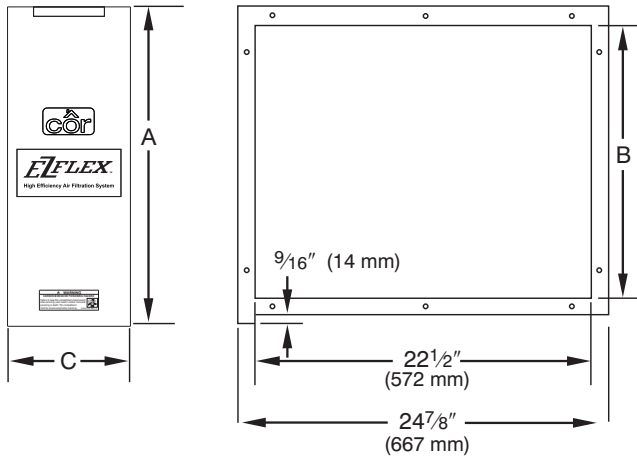

Fig. 5 - EZXCABCR Dimensions

A180072CR

MODEL EZXCAB	A	B	C
1016	16- 15/16" (430mm)	13- 7/8" (352mm)	7- 1/4" (184mm)
1020	20- 15/16" (532mm)	17- 7/8" (454mm)	7- 1/4" (184mm)

SELECT LOCATION FOR THE AIR CLEANER

Select a location that is readily accessible for periodic inspection and cleaning. Allow a minimum of 26-in. (660mm) in front of the access panel for EZ-Flex filter removal and replacement. For complete unit dimensions refer to Fig. 5.

DIRECTION OF AIR FLOW THROUGH THIS AIR CLEANER

The High Efficiency Air cleaner is set up for left to right airflow, when facing the access door. For right to left air flow remove EZ-Flex filter, turn it around and replace in cabinet. The directional arrows on the filter must point in the direction of air flow.

HUMIDIFIERS

Location of the system humidifier is important to the operation of the air cleaner. When an evaporator type humidifier is used, it may be installed between the furnace warm air duct and the return air duct without affecting the air cleaner.

INSTALLATION

⚠ WARNING

CARBON MONOXIDE HAZARD

Failure to follow this warning could result in personal injury or death.

Do not remove door during blower operation or operate blower with door removed or improperly latched.

⚠ CAUTION

CUT HAZARD

Failure to follow this caution may result in personal injury.

Sheet metal parts may have sharp edges or burrs. Use care and wear appropriate protective clothing and gloves when handling parts.

1. Turn off power disconnect and install lockout tag.
2. Check the rating given on this product to make sure it is suitable for your application.
3. Remove the old furnace filter and discard.

NOTE: The air cleaner cannot remove existing dirt from the blower and ducts.

NOTE: The following is a typical installation of this air cleaner on an upflow furnace. You may have to alter the installation to fit your specific application.

4. Locate the cabinet in the cold air return duct so that all of the return air flows through the unit. If the furnace and air cleaner openings are different, use a transition. See Fig. 3.

5. Mounting holes are provided for simple connection to duct work and unit cabinet. See Fig. 7. The .140 in. holes are sized for # 8 sheet metal screws, or 1/8 in. rivets. If the adjoining duct work is flanged, install the screws so that the screw heads are inside the cabinet. This will prevent damage to the EZ-Flex filter during removal and installation.

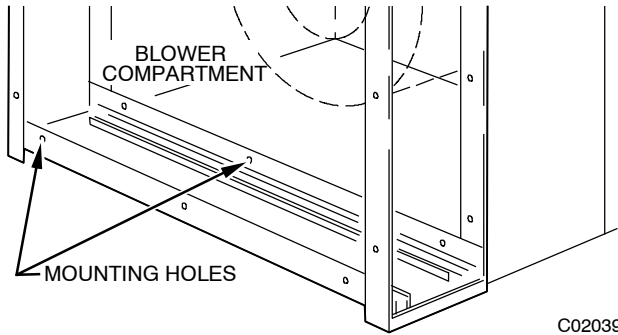

Fig. 7 - Mounting Holes

6. After the cabinet has been secured, use caulk or tape to seal seams airtight.
7. Remove Filter from box, assemble then place in cabinet. See Fig. 8.
8. Install access door and ensure a tight seal.

MAINTENANCE

HOW TO MAINTAIN YOUR AIR CLEANER

The filter media in your cabinet **MUST** be replaced periodically. The frequency of filter replacement is best determined by visual examination. On average, filters of this type should be replaced every 6–12 months under normal usage.

STEPS FOR REPLACING FILTER

1. Turn off power to blower.
2. Open access door by pulling the handle and lifting upward. Remove door completely.
3. Pull used filter straight out of cabinet and disassemble and discard media only.
4. Remove new filter from box and assemble. See Fig.8.
5. Slide new assembled filter into cabinet with Air-Flow arrow pointing in the direction of air flow.
6. Replace access door.

REPLACEMENT FILTERS

REPLACEMENT EZ-FLEX FILTERS FOR YOUR HIGH EFFICIENCY AIR FILTRATION SYSTEM

Remember, periodic inspection and twice annual replacement of your filter will ensure high efficiency air cleaning. Contact your HVAC dealer for replacement EZ-Flex Filters (See Table 2).

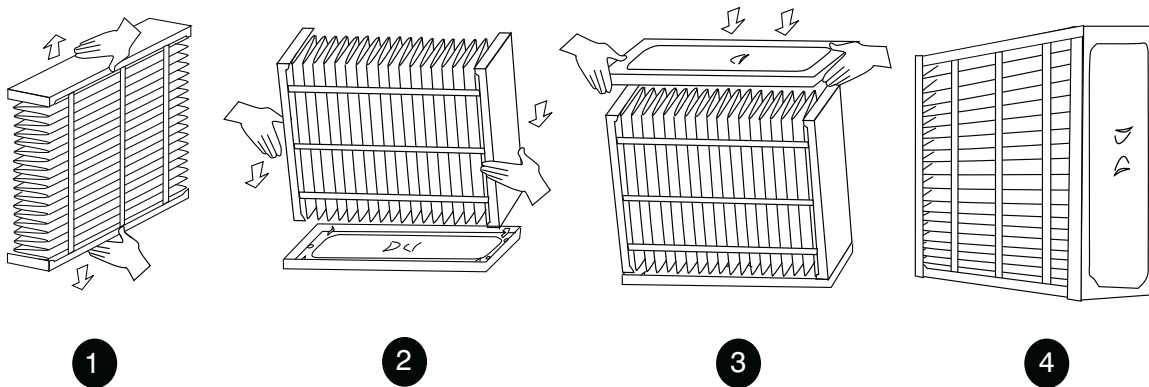

Fig. 8 - EZ-Flex Filter Assembly

A01397

Table 2 – Replacement Filters

PART NUMBER	MERV
EXPXXFIL0016	10
EXPXXFIL0316	13
EXPXXFIL0020	10
EXPXXFIL0320	13