

Installation Instructions

Direct Expansion
Fan Coil Unit

FB4BSX
50 HZ



NOTE: Read the entire instruction manual before starting the installation.

This symbol → indicates a change since the last issue.

SAFETY CONSIDERATIONS

Improper installation, adjustment, alteration, service, maintenance, or use can cause explosion, fire, electrical shock, or other conditions which may cause personal injury or property damage. Consult a qualified installer, service agency, or your distributor or branch for information or assistance. The qualified installer or agency must use factory-authorized kits or accessories when modifying this product. Refer to the individual instructions packaged with the kits or accessories when installing.

Follow all safety codes. Wear safety glasses and work gloves. Use quenching cloth for brazing operations. Have fire extinguisher available. Read these instructions thoroughly and follow all warnings or cautions attached to the unit. Consult local building codes and IEC code for special requirements.

Recognize safety information. This is the safety-alert symbol . When you see this symbol on the unit and in instructions or manuals, be alert to the potential for personal injury.

- Understand the signal word DANGER, WARNING, CAUTION, or NOTE. These words are used with the safety-alert symbol. DANGER identifies the most serious hazards which **will** result in severe personal injury or death. WARNING signifies hazards which **could** result in personal injury or death. CAUTION is used to identify unsafe practices which **would** result in minor personal injury or product and property damage. NOTE is used to highlight suggestions which will result in enhanced installation, reliability, or operation.

 **WARNING:** Before installing or servicing unit, always turn off all power to unit. There may be more than 1 disconnect switch. Turn off accessory heater power if applicable. Electrical shock can cause personal injury or death.

-  **WARNING:** Do not operate unit in the vicinity of toxic or flammable material. Failure to do so can result in personal injury or death.
-

INSTALLATION

PROCEDURE 1—MOUNT UNIT

Unit can stand or lie on floor, or hang from ceiling or wall. Allow space for wiring, piping, and servicing unit.

IMPORTANT: When unit is installed over a finished ceiling and/or living area, building codes may require a field-supplied secondary condensate pan to be installed under the entire unit. Some localities may allow as an alternative, the running of a separate, secondary condensate line. Consult local codes for additional restrictions or precautions.

A. Upflow Installation

If return air is to be ducted through a floor, set unit on floor over opening and use 1/8- to 1/4-in. thick fireproof resilient gasket between duct, unit, and floor.

Side return is a field option on slope coil models. Cut opening per dimensions. (See Fig. 1.) A field-supplied bottom closure is required.

B. Downflow Installation

- **NOTE:** To convert units for downflow applications, refer to Installation Instructions supplied with kit for proper installation. For slope fan coils, use kit Part No. KFADC0201SLP. For A fan coils use kit Part No. KFADC0401ACL. Use fireproof resilient gasket, 1/8- to 1/4-in. thick, between duct, unit, and floor.

- **NOTE:** Gasket kit number KFAHD0101SLP is also required for all downflow applications to maintain low air leak/low sweat performance.

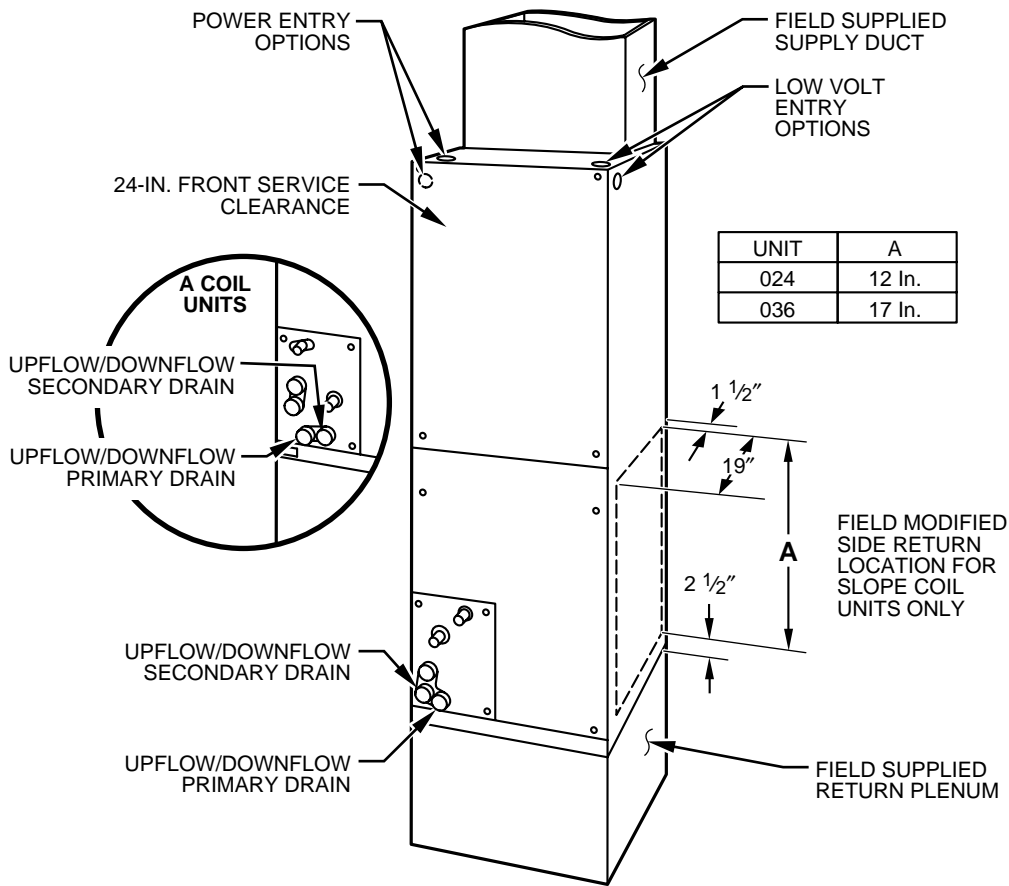

Fig. 1—Slope Coil Unit in Upflow Application

A96375

- **CAUTION:** The conversion of the fan coil to downflow requires special procedures for the condensate drains on both A-coil and Slope units. The vertical drains have an overflow hole between the primary and secondary drain holes. This hole is plugged for all applications except downflow, but must be used for downflow. During the conversion process, remove the plastic cap covering the vertical drains only and discard. Remove the plug from the overflow hole and discard. At completion of the downflow installation, caulk around the vertical pan fitting to door joint to retain the low air leak performance of the unit.

C. Horizontal Installation

Units must not be installed with access panels facing up or down. All units are factory built for horizontal left installation. When suspending unit from ceiling, dimples in casing indicate suitable location of screws for mounting metal support straps. (See Fig. 2.)

- CAUTION:** For optimum condensate drainage performance in horizontal installations, unit should be leveled along its length and width.

NOTE: The 070 modular unit can be disassembled and components moved separately to installation area for reassembly. This process accommodates small scuttle holes and limiting entrances to installation sites. (See Fig. 3.)

HORIZONTAL RIGHT CONVERSION OF UNITS WITH SLOPE COILS

- **NOTE:** Gasket kit number KFAHD0101SLP is required for horizontal slope coil conversion to maintain low air leak/low sweat performance.
1. Remove blower and coil access panels and fitting panel. (See Fig. 4.)
 2. Remove coil mounting screw securing coil assembly to right-side casing flange.
 3. Remove coil assembly.
 4. Lay fan coil unit on its right side and reinstall coil assembly with condensate pan down. (See Fig. 4.)
 5. Attach coil to casing flange using coil mounting screw previously removed.
 6. Make sure the pan cap in the fitting door is properly seated on the fitting door to retain the low air leak rating of the unit.
 7. Align holes with tubing connections and condensate pan connections, and reinstall access panels and fitting panel.

NOTE: Make sure liquid and suction tube grommets are in place to prevent air leaks and cabinet sweating. Install after brazing.

HORIZONTAL RIGHT CONVERSION OF UNITS WITH A-COIL

1. Remove blower and coil access panels. (See Fig. 5.)
2. Remove metal clip securing fitting panel to condensate pan. Remove fitting panel.
3. Remove 2 snap-in clips securing A-coil in unit.

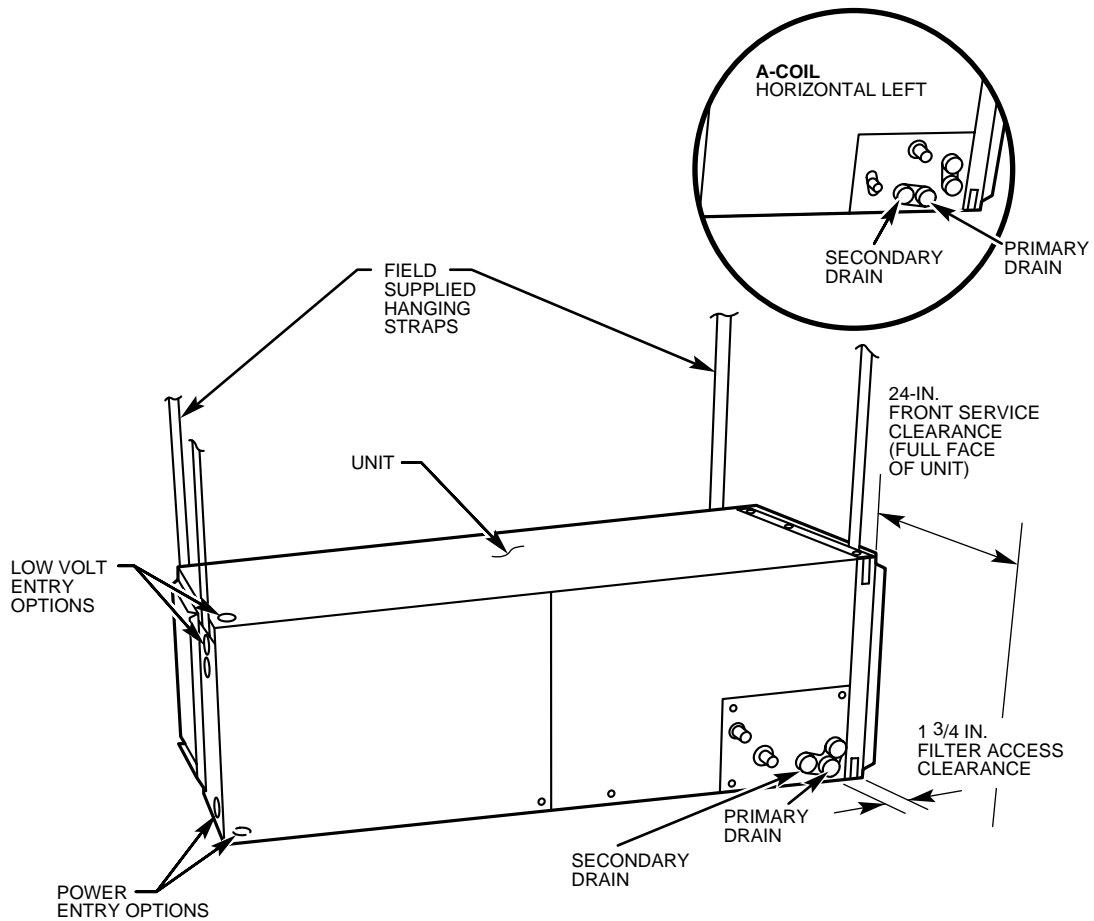

Fig. 2—Slope Coil Unit in Horizontal Left Application

A95292

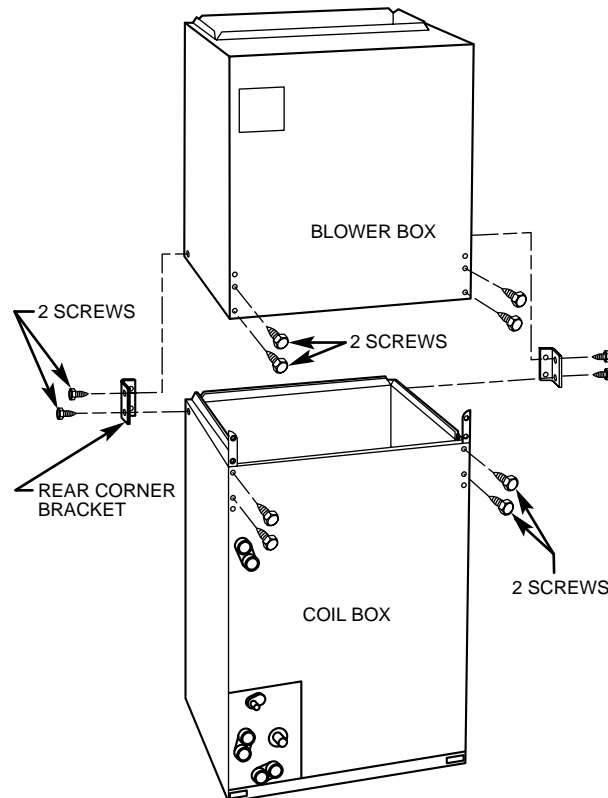
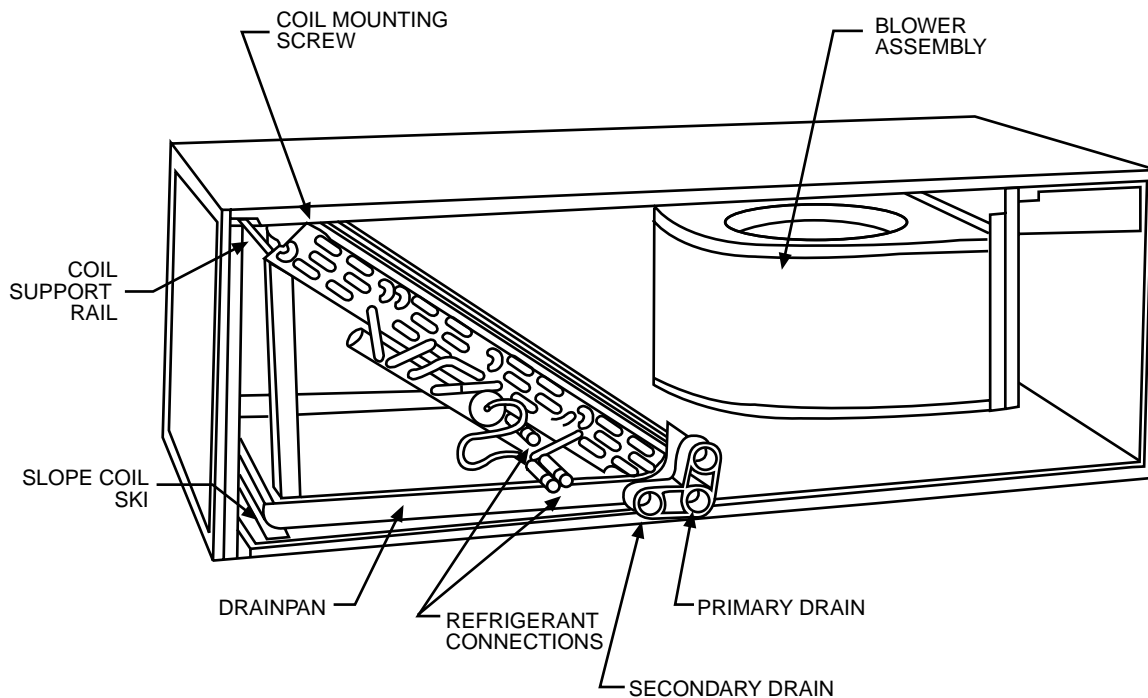

Fig. 3—Removal of Brackets on 070 Modular Unit

A95293

4. Slide coil and pan assembly out of unit.
5. Remove horizontal drain pan support bracket from coil support rail on left side of unit and reinstall on coil support rail on right side of unit.



→ Fig. 4—Conversion for Horizontal Right Applications Using a Slope Coil

A03001

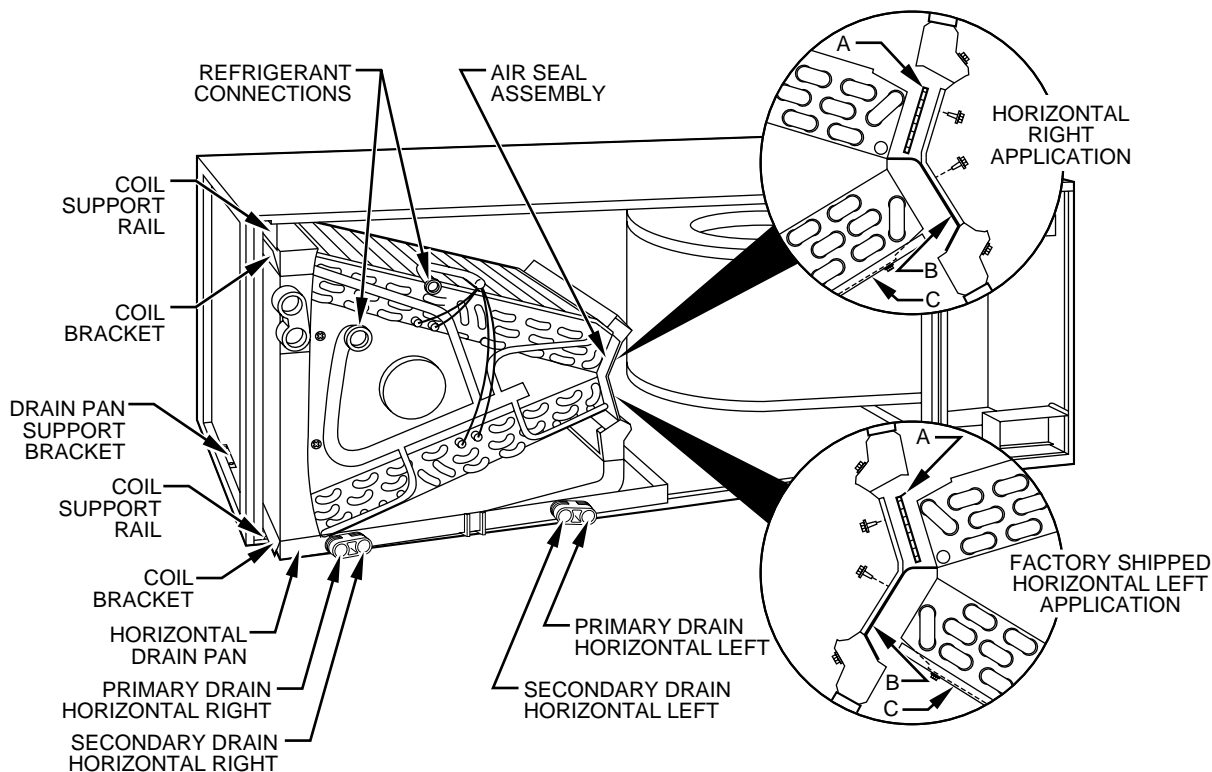

Fig. 5—Conversion for Horizontal Right Applications Using A-Coil

A95286

6. Convert air-seal assembly for horizontal right
 - a. Remove air-seal assembly from coil by removing 4 screws.
 - b. Remove air splitter (B) from coil seal assembly by removing 3 screws. (See Fig. 5—factory-shipped inset.)
 - c. Remove filler plate (A) and install air splitter (B) in place of filler plate.
 - d. Install filler plate (A) as shown in horizontal right application.
 - e. Remove condensate troughs (C) and install on opposite tube sheets.
 - f. Install hose onto plastic spout.
7. Install horizontal pan on right side of coil assembly.

8. Slide coil assembly into casing. Be sure coil bracket on each corner of vertical pan engages coil support rails.
9. Reinstall 2 snap-in clips to correctly position and secure coil assembly in unit. Be sure clip with large offset is used on right side of unit to secure horizontal pan.
- 10. Remove two oval fitting caps from left side of the coil, access panel, and fitting panel.
11. Remove insulation knockouts on right side of coil access panel.
12. Remove 2 oval coil access panel plugs and reinstall into holes on left side of coil access panel and fitting panel.
- 13. Install condensate pan fitting caps (from Step 10) in the right side of the coil door making sure that the cap snaps and seats cleanly on the back side of the coil door. Make sure no insulation interferes with seating of the cap.
14. Reinstall access and fitting panels, aligning holes with tubing connections and condensate pan connections. Be sure to reinstall metal clip between fitting panel and vertical condensate pan.

Make sure liquid and suction tube grommets are in place to prevent air leaks and cabinet sweating.

PROCEDURE 2—AIR DUCTS

Connect the supply-air duct over the outside of the 3/4-in. flanges provided on the supply-air opening. Secure the duct to the flange, using proper fasteners for the type of duct used, and seal the duct-to-unit joint. If return-air flanges are required, install factory-authorized accessory kit.

Use flexible connectors between ductwork and unit to prevent transmission of vibration. When electric heater is installed, use heat-resistant material for flexible connector between ductwork and unit at discharge connection. Ductwork passing through unconditioned space must be insulated and covered with vapor barrier.

A. Ductwork Acoustical Treatment

Metal duct systems that do not have a 90° elbow and 10 ft of main duct to first branch takeoff may require internal acoustical insulation lining. As an alternative, fibrous ductwork may be used if constructed and installed in accordance with the latest edition of SMACNA construction standard on fibrous glass ducts. Both acoustical lining and fibrous ductwork shall comply with National Fire Protection Association as tested by UL Standard 181 for Class 1 air ducts.

PROCEDURE 3—ELECTRICAL CONNECTIONS

All products from the factory utilize a printed-circuit board (PCB) which has a low voltage circuit protective fuse (5 amp), fan motor speed selection terminal (SPT), and time delay relay (TDR) jumper. To disable the TDR feature, sever the jumper wire. (See Fig. 6.)

⚠ CAUTION: If a disconnect switch is to be mounted on the unit, select a location where drill or fastener will not contact electrical or refrigerant components.

Before proceeding with electrical connections, make certain that supply voltage, frequency, phase, and ampacity are as specified on the unit rating plate. See unit wiring label for proper field high- and low-voltage wiring. Make all electrical connections in accordance with the IEC and any local codes or ordinances that may apply. Use copper wire only.

The unit must have a separate branch electric circuit with a field-supplied disconnect switch located within sight from and readily accessible from the unit.

⚠ WARNING: Field wires on the line side of the disconnect found in the fan coil unit remain live, even when the pull-out is removed. Service and maintenance to incoming wiring can not be performed until the main disconnect switch (remote to the unit) is turned off. Failure to do so will result in electrical shock causing personal injury or death.

A. Line Voltage Connections

Connect 230-1-50 motor power supply to unit terminal block marked L1 and N. Connect field ground to unit ground lug marked PE. Refer to wiring label affixed to blower housing for detail.

NOTE: It is not necessary to cover the opening for accessory heaters. The unit will perform properly with opening uncovered.

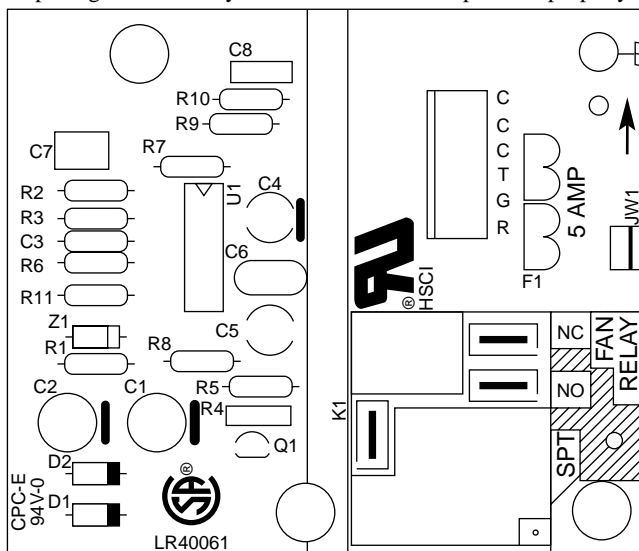

→ Fig. 6—Fan Coil Printed-Circuit Board

B. 24-v Control System

CONNECTION TO UNIT

Wire low voltage in accordance with the wiring label on the blower. (See Fig. 7, 8, 9, 10, and 11.) Use No. 18 AWG color-coded, insulated (35°C minimum) wire to make the low-voltage connections between the thermostat, the unit, and the outdoor equipment. If the thermostat is located more than 100 ft from the unit (as measured along the low-voltage wire), use No. 16 AWG color-coded, insulated (35°C minimum) wire. All wiring must be NEC Class 1 and must be separated from incoming power leads.

Refer to outdoor unit wiring instructions for any additional wiring procedure recommendations.

C. Electric Heater

Electric heaters are not offered as accessories with the CE marked fan coil units. If heaters are required for the application, use of other certified heaters installed in the air duct per local electrical codes is suggested.

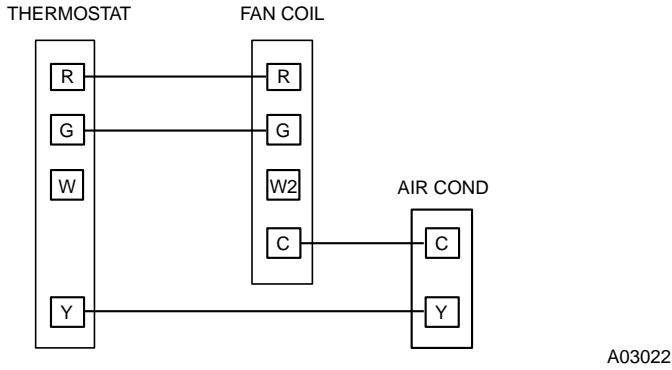

Fig. 7—Wiring Layout Air Conditioning Unit (Cooling Only)

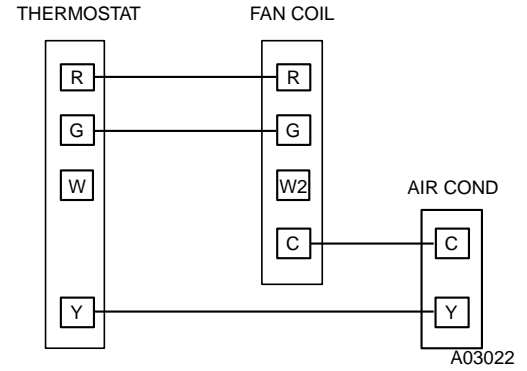

Fig. 8—Wiring Layout Air Conditioning Unit (Cooling and 1-Stage Heat)

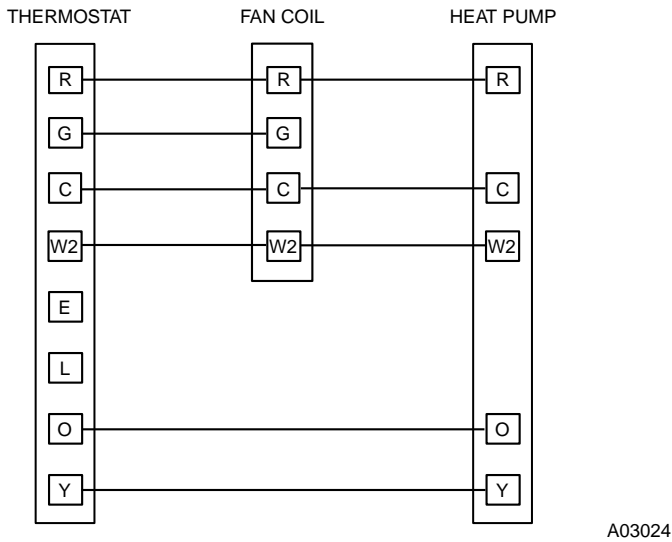

Fig. 9—Wiring Layout Heat Pump Unit (Cooling and 2-Stage Heat with No Outdoor Thermostat)

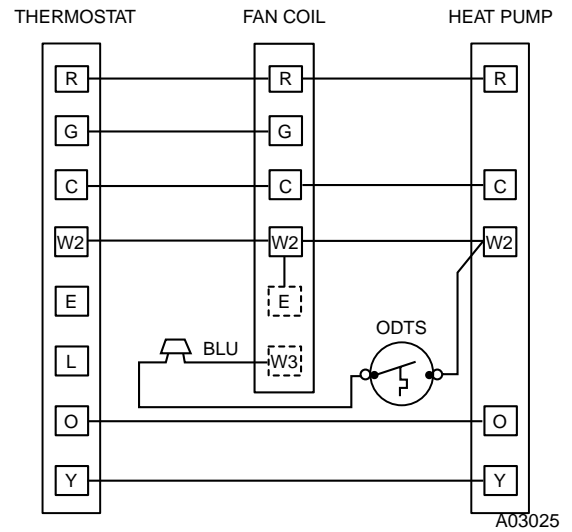

Fig. 10—Wiring Layout Heat Pump Unit (Cooling and 2-Stage Heat with 1 Outdoor Thermostat)

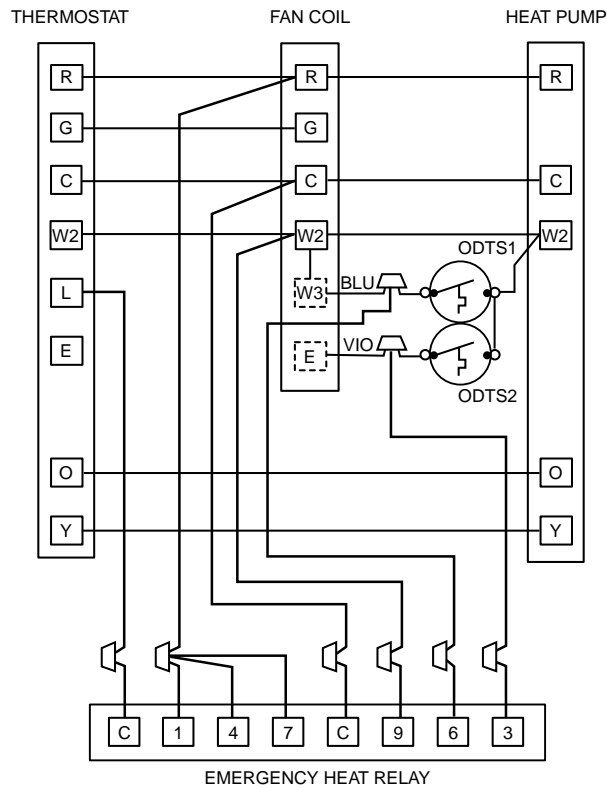

Fig. 11—Wiring Layout Heat Pump Unit (Cooling and 2-Stage Heat with 2 Outdoor Thermostats)

A03026

TRANSFORMER INFORMATION

Transformer is factory wired for 230-v operation. For 200-v applications, disconnect the black wire from the 230-v terminal on the transformer and connect it to the 200-v terminal. (See Fig. 12.)

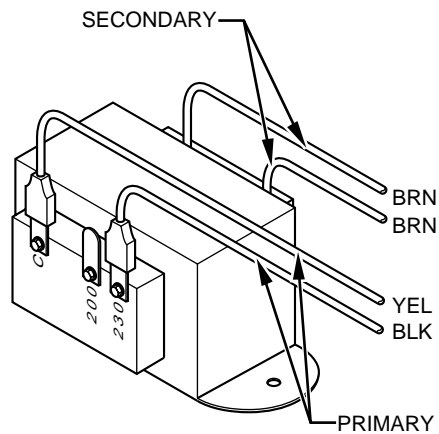

Fig. 12—Transformer Connections

96514

HEATER STAGING

The controls are factory-circuited for single-stage operation. For 2-stage operation, use outdoor thermostat kit KHAOT0301FST, and for 3-stage use both kits KHAOT0201SEC and KHAOT0301FST.

When 2 stages are desired, cut W3 at the W2 wire nut, strip and reconnect per the thermostat kit instruction. (See Fig. 10.) When 3 stages are desired, cut the W2 wire nut off and discard. Strip W2, W3, and E and reconnect per thermostat kit instructions. (See Fig. 11.)

NOTE: When 3 stages are used or anytime the E terminal is not tied to W2, the emergency heat relay, part of outdoor thermostat kit KHAOT0201SEC must be used.

D. Ground Connections

⚠ WARNING: According to NEC, ANSI/NFPA 70, and local codes, the cabinet must have an uninterrupted or unbroken ground to minimize personal injury if an electrical fault should occur. The ground may consist of electrical wire or metal conduit when installed in accordance with existing electrical codes. Failure to follow this warning could result in electric shock, fire, or death.

Use UL-listed conduit and conduit connector for connecting supply wire(s) to unit to obtain proper grounding. Grounding may also be accomplished by using grounding lugs provided in control box.

E. Minimum CFM and Motor Speed Selection

Units with or without electric heaters require a minimum CFM. Refer to the unit wiring label to ensure that the fan speed selected is not lower than the minimum fan speed indicated.

Fan speed selection is done at the fan relay on the printed-circuit board. To change motor speeds, disconnect the fan lead used on the relay terminal (SPT) and replace with the motor speed tap desired. (See Fig. 13.) Save the insulating cap and place on the motor lead removed from the relay.

NOTE: In low static applications, lower motor speed tap should be used to reduce possibility of water being blown off coil.

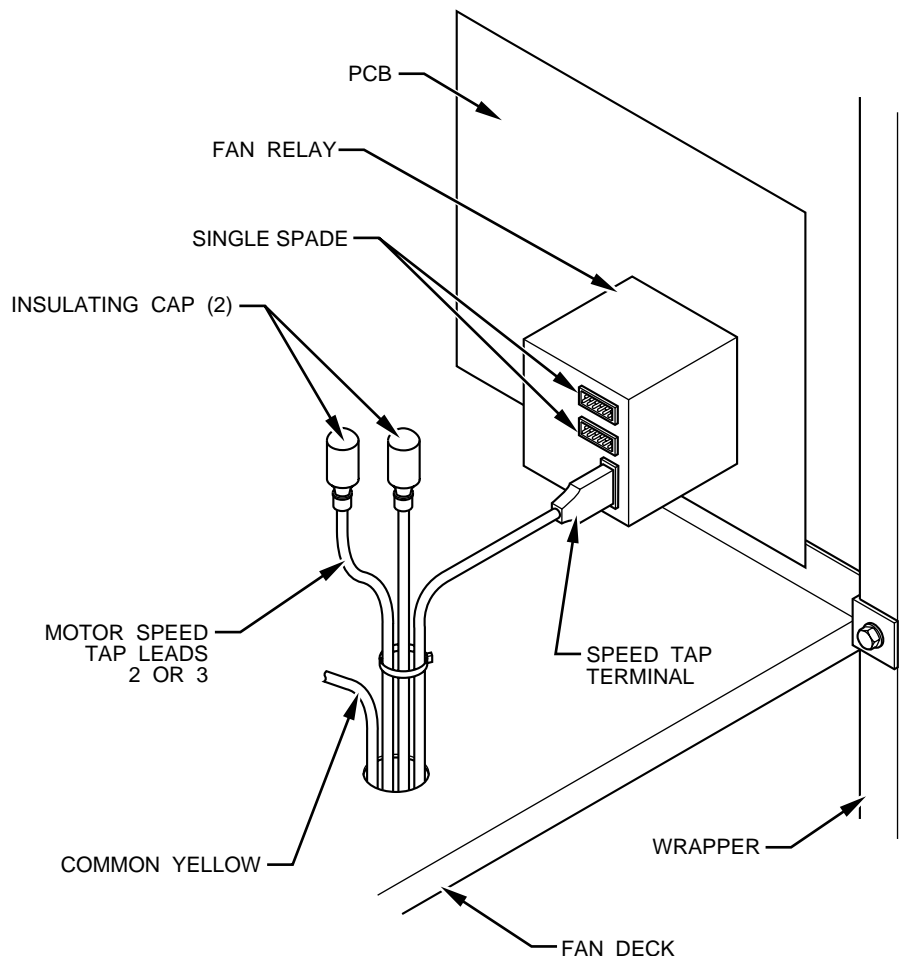

Fig. 13—Fan Coil Fan Relay and Speed Tap Terminal

A94068

All units have 3 motor speed taps. Low speed (red) is designed for mismatch outdoor unit applications. Medium speed (blue) is designed for straight matched operations. High speed (black) is used with high external static duct systems of straight matched systems.

PROCEDURE 4—REFRIGERANT TUBING

Use accessory tubing package or field-supplied tubing of refrigerant grade. Suction tube must be insulated. Do not use damaged, dirty, or contaminated tubing because it may plug refrigerant flow-control device. ALWAYS evacuate the coil and field-supplied tubing before opening outdoor unit service valves.

→ **⚠ CAUTION:** A brazing shield **MUST** be used when tubing sets are being brazed to the unit connections to prevent damage to the unit surface and condensate pan fitting caps.

→ Units have sweat suction and liquid tube connections. Make suction tube connection first.

1. Cut tubing to correct length.

2. Insert tube into sweat connection on unit until it bottoms.
3. Braze connection using silver bearing or non-silver bearing brazing materials. Do not use solder (materials which melt below 800°F). Consult local code requirements.

→ **CAUTION:** Wrap a wet cloth around rear of fitting to prevent damage to TXV and factory-made joints.

4. Evacuate coil and tubing system to 500 microns using deep vacuum method.

PROCEDURE 5—REFRIGERANT FLOW-CONTROL DEVICE

CAUTION: If using a TXV in conjunction with a reciprocating compressor, a compressor start capacitor and relay are required. Consult outdoor unit pre-sale literature for start assist kit Part No.

Replace piston if required. Check piston size shown on indoor unit rating plate to see if it matches required piston shown on outdoor unit rating plate. If it does not match, replace indoor piston with piston shipped with outdoor unit. The piston shipped with outdoor unit is correct for any approved indoor coil combination. (See Fig. 14.)

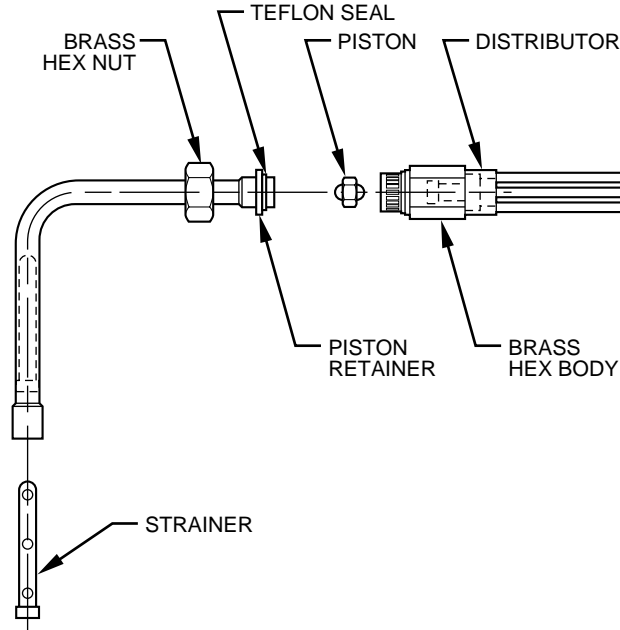

Fig. 14—Refrigerant Flow-Control Device

A94415

PROCEDURE 6—CONDENSATE DRAINS

→ To connect drains, the cap openings must be removed. Use a knife to start the opening near the tab and using pliers, pull the tab to remove the disk. Clean the edge of the opening if necessary and install the condensate line. Finally caulk around the lines where they exit the fitting to retain the low leak rating of the unit.

→ **CAUTION:** The conversion of the fan coil to downflow requires special procedures for the condensate drains on both A-coil and Slope units.

The vertical drains have an overflow hole between the primary and secondary drain holes. This hole is plugged for all applications except downflow, but must be used for downflow.

During the conversion process, remove the plastic cap covering the vertical drains only and discard. Remove the plug from the overflow hole and discard. At completion of the downflow installation, caulk around the vertical pan fitting to door joint to retain the low air leak performance of the unit.

Units are equipped with primary and secondary 3/4-in. FPT drain connections. It is recommended that PVC fittings be used on the plastic condensate pan. Do not over-tighten. Finger-tighten plus 1-1/2 turns. For proper condensate line installation review Fig. 1, 2, 4, and 5.

CAUTION: To prevent property damage and achieve optimum drainage performance, BOTH primary and secondary drain lines should be installed and include properly-sized condensate traps. (See Fig. 15.) Shallow, running traps are inadequate and DO NOT allow proper condensate drainage. (See Fig. 16.) Use pipe dope. Do not over-torque. Hand-tighten plus 1-1/2 turns.

NOTE: When connecting condensate drain lines, avoid blocking filter access panel, thus preventing filter removal. After connection, prime both primary and secondary condensate traps.

NOTE: If the unit is located in or above a living space where damage may result from condensate overflow, a field-supplied, external condensate pan should be installed underneath the entire unit, and a secondary condensate line (with appropriate trap) should be run from the unit into the pan. Any condensate in this external condensate pan should be drained to a noticeable place. As an alternative to using an external condensate pan,

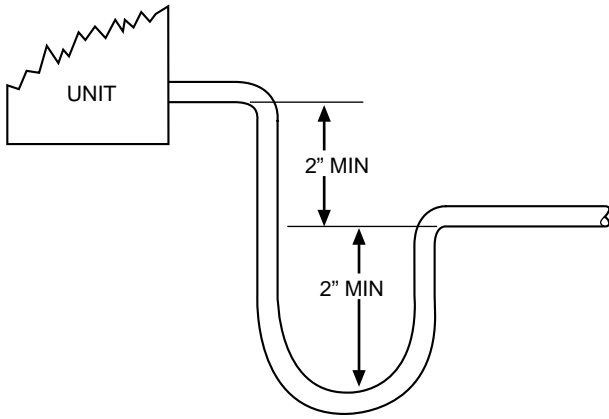

A03002

→ **Fig. 15—Recommended Condensate Trap**



DO NOT USE SHALLOW RUNNING TRAPS!

A03013

→ **Fig. 16—Insufficient Condensate Trap**

some localities may allow the running of a separate 3/4-in. condensate line (with appropriate trap) to a place where the condensate will be noticeable. The owner of the structure must be informed that when condensate flows from the secondary drain or external condensate pan, the unit requires servicing else water damage will occur.

Install traps in the condensate lines as close to the coil as possible. (See Fig. 17.) Make sure that the outlet of each trap is below its connection to the condensate pan to prevent condensate from overflowing the drain pan. Prime all traps, test for leaks, and insulate traps if located above a living area.

Condensate drain lines should be pitched downward at a minimum slope of 1 in. for every 10 ft of length.

Consult local codes for additional restrictions or precautions.

START-UP

Refer to outdoor unit Installation Instructions for system start-up instructions and refrigerant charging method details.

⚠ CAUTION: Never operate unit without a filter. Damage to blower motor or coil may result. Factory-authorized filter kits must be used when locating the filter inside the unit. For those applications where access to an internal filter is impractical, a field-supplied filter must be installed in the return duct system.

CARE AND MAINTENANCE

To continue high performance and minimize possible equipment failure, it is essential that periodic maintenance be performed on this equipment. Consult your local dealer as to the proper frequency of maintenance and the availability of a maintenance contract.

The ability to properly perform maintenance on this equipment requires certain mechanical skills and tools. If you do not possess these, contact your dealer for maintenance. The only consumer service recommended or required is filter replacement or cleaning on a monthly basis.

⚠ WARNING: Relieve pressure and recover all refrigerant before system repair or final unit disposal to avoid personal injury or death. Use all service ports and open all flow-control devices, including solenoid valves.

⚠ CAUTION: Do not vent refrigerant to atmosphere. Recover during system repair or final unit disposal.

Operating outdoor temperature ranges of a fan coil in a matched system are listed in Table 1.

Table 1—Operating Outdoor Temperature Ranges

Cooling	125°F(51.7°C) MAX.
	55°F(12.8°C) Min. (W/O low ambient control)
Heating	66°F(18.9°C) Max.
	-30°F(-34.4°C) Min.

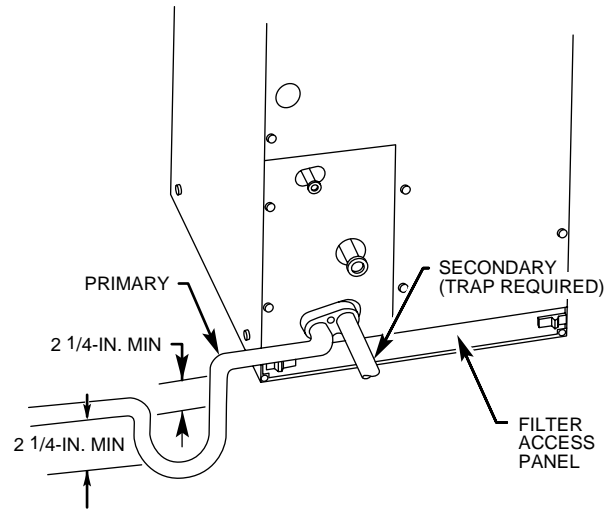

Fig. 17—Condensate Drain

A90173

