

**Sizes:**  
**014, 017, 021, 024**

# **FNCCAB** **High Efficiency Filtration System** **For Fan Coils**

## **Installation Instructions**

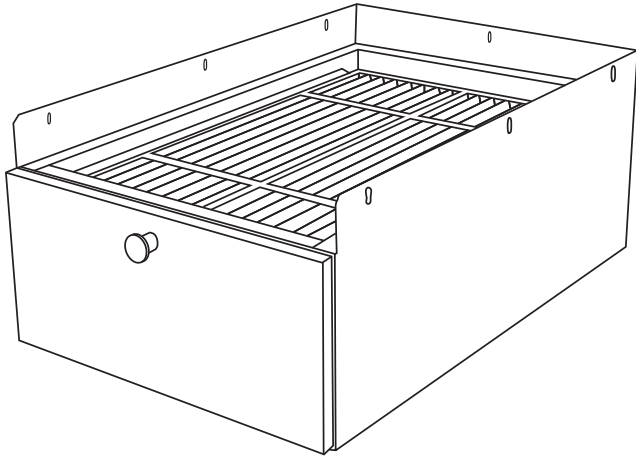

C04032

**Fig. 1 - FNCCAB High Efficiency Air Filtration System**

**NOTE:** Read the entire instruction manual before starting the installation.

### **SAFETY CONSIDERATIONS**

Improper installation, adjustment, alteration, service, maintenance, or use can cause explosion, fire, electrical shock, or other conditions which may cause death, personal injury, or property damage. Consult a qualified installer, service agency, or your distributor or branch for information or assistance. The qualified installer or agency must use factory-authorized kits or accessories when modifying this product. Refer to the individual instructions packaged with the kits or accessories when installing.

Follow all safety codes. Wear safety glasses, protective clothing, and work gloves. Use quenching cloth for brazing operations. Have fire extinguisher available. Read these instructions thoroughly and follow all warnings or cautions included in literature and attached to the unit. Consult local building codes and current editions of the National Electrical Code (NEC) NFPA 70. In Canada, refer to current editions of the Canadian electrical code CSA 22.1.

Recognize safety information. This is the safety-alert symbol . When you see this symbol on the furnace and in instructions or manuals, be alert to the potential for personal injury. Understand the signal words **DANGER**, **WARNING**, **CAUTION** and **NOTE**. The words **DANGER**, **WARNING**, and **CAUTION** are used with the safety alert symbol. **DANGER** identifies the most serious hazards which **will** result in severe personal injury or death. **WARNING** signifies a hazard which **could** result in personal injury or death. **CAUTION** is used to identify unsafe practices

which **may** result in minor personal injury or product and property damage. **NOTE** is used to highlight suggestions which **will** result in enhanced installation, reliability, or operation.

### **INTRODUCTION**

These instructions cover the installation, operation and maintenance of FNCCAB High Efficiency Air Filtration System. Become familiar with the components listed in Table 1. See Fig. 2.

**Table 1 – FNCCAB Major Components**

<b>COMPONENT</b>	<b>DESCRIPTION</b>
1	Cabinet
2	Filter
3	Access Handle
4	Access Door
5	Door Latch Hardware
6	Door Alignment Table

### **DESCRIPTION AND USAGE**

#### **CAUTION**

##### **UNIT OPERATION AND SAFETY HAZARD**

Failure to follow this caution may result in personal injury and/or damage to the equipment.

Prior to installing this product, you should read these entire instructions and follow all directions.

### **APPLICATION**

This High Efficiency Air Filtration System must be used in a forced air heating, cooling or ventilation system. This High Efficiency Air Filtration System cleaner should be installed in the system so that all the system air is circulated through this air cleaner. The High Efficiency Air Filtration System will only remove the airborne contaminants delivered to it. Maximum performance is obtained when the system blower is set for continuous operation.

### **INSTALLATION REQUIREMENTS**

The location for the High Efficiency Air Filtration System is on the return side of the fan coil next to the blower compartment. In this location, both the blower motor and cooling coils will be kept clean. Do not install the air cleaner in the discharge (supply) air duct. The front of this unit must be readily accessible for periodic inspection and replacement of filter to maintain maximum efficiency and trouble-free operation.

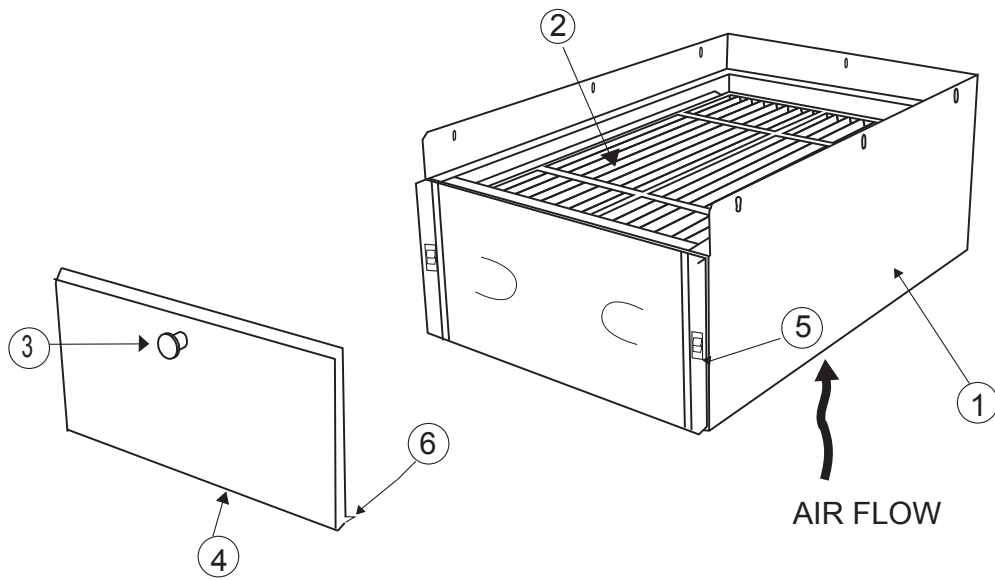

**Fig. 2 - FNCCAB Major Components**

C04033

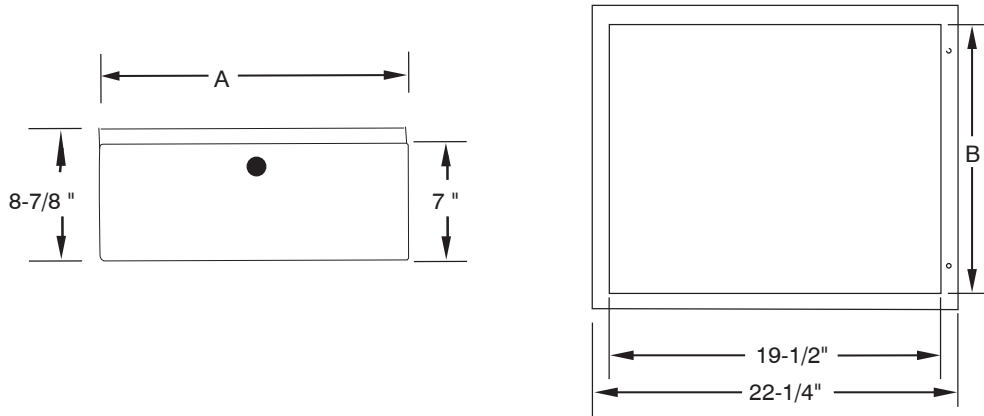

**Fig. 3 - FNCCAB Dimensions**

C04031

**Table 2 – Dimensions and Airflow**

MODELS	FNCCAB-0014	FNCCAB-0017	FNCCAB-0021	FNCCAB-0024
Airflow (CFM) Range	600-900	600-1350	600-2000	600-2200
A	14-5/16-in (36 cm)	17-5/8-in (45 cm)	21-1/8-in (54 cm)	24-5/8-in (63 cm)
B	11-in (28 cm)	14-11/32-in (36 cm)	17-7/8-in (45 cm)	21-11/32-in (54 cm)

**Table 3 – Typical Pressure Drop**

TYPICAL PRESSURE DROP					
Airflow Range (CFM)	Resistance (in. w.c.)				
	Typical Factory-supplied Filter in Fan Coil Unit	Model Number			
		FNCCAB-0014	FNCCAB-0017	FNCCAB-021	FNCCAB-0024
600	.044	.125	.060	.040	.015
800	.075	.150	.090	.060	.030
1000	.072	.250	.125	.070	.040
1200	.100	-	.180	.090	.060
1400	.092	-	.250	.140	.090
1600	.120	-	-	.187	.125
1800	.152	-	-	.230	.150
2000	.187	-	-	.280	.190
2200	-	-	-	-	.250

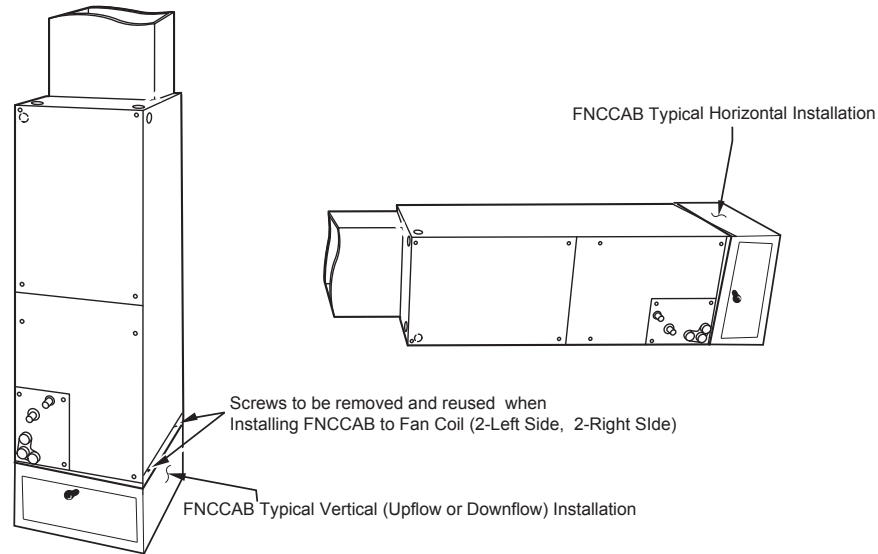

**Fig. 4 - Typical Installation**

C04029

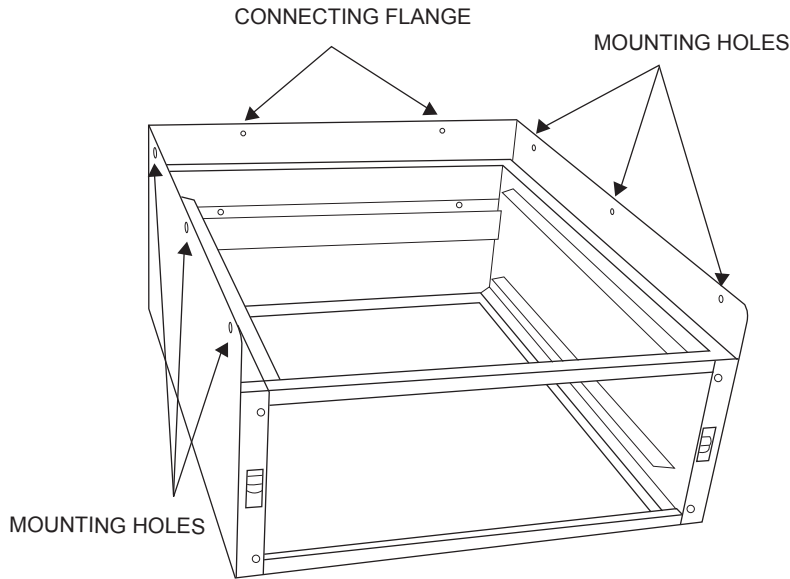

**Fig. 5 - Mounting Holes and Mounting Flange**

C04034

**SELECT LOCATION FOR THE AIR CLEANER**

Select a location that is readily accessible for periodic inspection and cleaning. Allow a minimum of 26-in. in front of the access panel for filter removal and replacement. For complete unit dimensions refer to Fig. 3.

**IMPORTANT:** Failure to replace filter can cause damage to the system.

This High Efficiency Air cleaner can be mounted in several positions. See Fig. 4 for proper air cleaner mounting with a variety of installation styles.

**⚠ CAUTION**

**CUT HAZARD**

Failure to follow this caution may result in personal injury. Sheet metal parts may have sharp edges or burrs. Use care and wear appropriate protective clothing and gloves when handling these parts.

**⚠ WARNING**

**ELECTRICAL SHOCK HAZARD**

Failure to follow this warning could result in personal injury or death.

Only a trained, experienced service person should install this air cleaner. A thorough checkout of the unit installation should be completed before unit operation. Before performing installation, service or maintenance operations on unit, turn off all power to unit. TAG DISCONNECT SWITCH WITH LOCKOUT TAG.

## INSTALLATION

1. Turn off power disconnect and install lockout tag.
2. Check the airflow rating given on this product to make sure it is suitable for your application.
3. Remove the fan coil filter door and the factory supplied 1-in air filter. Discard filter and reinstall filter door.

**NOTE:** The air cleaner cannot remove existing dirt from the blower and ducts.

**NOTE:** The following is a typical installation of this air cleaner on an upflow furnace. You may have to alter the installation to fit your specific application.

4. Remove screws from the fan coil edge (return side) and retain for use once FNCCAB is in place.
5. Slide FNCCAB installation connecting flange over fan coil cabinet (return side) edge.
6. Mounting holes are provided for simple connection to unit cabinet. See Fig. 5. The clearance slots/holes are sized for #10 sheet metal screws or pop rivets. Reinstall the four screws removed in item 4 above, then shoot screws into remaining four clearance slots/holes of FNCCAB. If the adjoining duct work is flanged, install the screws so that the screw heads are inside the cabinet. This will prevent damage to the filter during removal and installation.
7. After the cabinet has been secured, use caulk or tape to seal connecting seams airtight to the bottom opening as required.
8. If not already installed, slide filter into mounted FNCCAB.
9. Install access door and ensure a tight seal. See Fig. 6.

## OWNERS MANUAL SECTION

### FNCCAB and FILFNC Maintenance

#### How to Maintain your air cleaner

The filter media in your cabinet **MUST** be replaced periodically. The frequency of filter replacement is best determined by visual examination.

On average, filters of this type should be replaced before each heating and each cooling season under normal usage (or at least yearly under minimum usage).

#### Steps for Replacing Filter

1. Turn off power to blower.
2. Open access door by pulling the handle. Remove door completely.
3. Pull used filter straight out of cabinet and discard.
4. Remove new filter from packaging.
5. Slide new filter into cabinet with Air-Flow arrow pointing in the direction of air flow (toward fan coil cabinet).
6. Replace access door. See Fig. 6.
7. Turn on power to blower.

### REPLACEMENT FILTERS

#### REPLACEMENT FILTERS FOR YOUR HIGH EFFICIENCY AIR FILTRATION SYSTEM

Remember, periodic inspection and replacement of your filter will ensure high efficiency air cleaning. Contact your HVAC dealer for replacement filters. See Table 4.

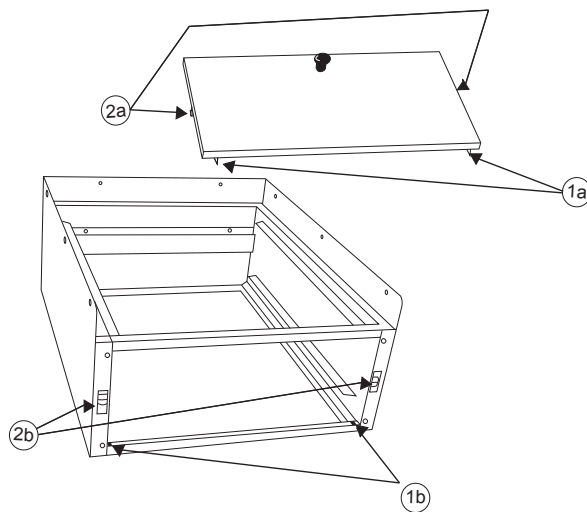

#### FNCCAB Door Latching Procedure

- Step 1-Fully Insert Door Alignment Tabs (1a) into Cabinet Slots (1b)  
 Step 2-Firmly Pivot Door upward to Capture Door Tabs (2a) into Cabinet Latching Mechanism (2b)

**Fig. 6 - Door Assembly Detail View**

C04035

**Table 4 – Replacement Filter Order Number**

MERV 8	FILXXFNC0014	FILXXFNC0017	FILXXFNC0021	FILXXFNC0024
MERV 11	FILXXFNC0114	FILXXFNC0117	FILXXFNC0121	FILXXFNC0124
Quantity per carton	2	2	2	2