

Installation Instructions

Fan Coil for Puron® Refrigerant
002, 003, 005, 006

FV4B

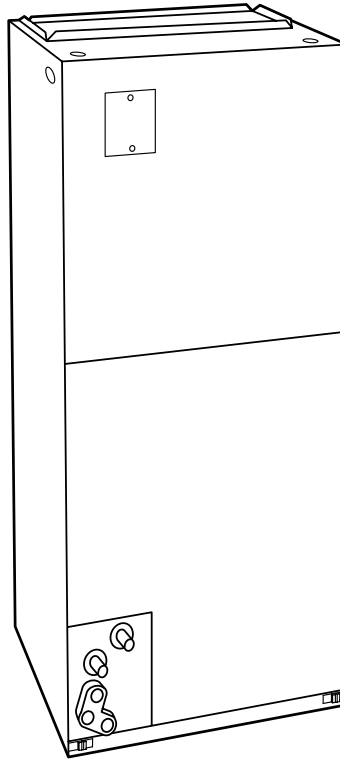

Fig. 1—Model FV4B

A98023

NOTE: Read the entire instruction manual before starting the installation.

This symbol → indicates a change since the last issue.

SAFETY CONSIDERATIONS

Improper installation, adjustment, alteration, service, maintenance, or use can cause explosion, fire, electrical shock, or other conditions which may cause personal injury or property damage. Consult a qualified installer, service agency, or your distributor or branch for information or assistance. The qualified installer or agency must use factory-authorized kits or accessories when modifying this product. Refer to the individual instructions packaged with kits or accessories when installing.

Follow all safety codes. Wear safety glasses and work gloves. Use quenching cloth for brazing operations. Have fire extinguisher available. Read these instructions thoroughly and follow all warnings or cautions attached to the unit. Consult local building codes and National Electrical Code (NEC) for special requirements.

Recognize safety information. This is the safety-alert symbol . When you see this symbol on the unit and in instructions manuals, be alert to the potential for personal injury.

Understand the signal words DANGER, WARNING, CAUTION, and NOTE. These words are used with the safety-alert symbol. DANGER identifies the most serious hazards which **will** result in severe personal injury or death. WARNING signifies hazards which **could** result in personal

injury or death. CAUTION is used to identify unsafe practices which **would** result in minor personal injury or product and property damage. NOTE is used to highlight suggestions which will result in enhanced installation, reliability, or operation.

⚠ WARNING: Before installing or servicing unit, always turn off all power to unit. There may be more than 1 disconnect switch. Turn off accessory heater power if applicable. Electrical shock can cause personal injury or death.

INTRODUCTION

Model FV4B Fan Coil units are designed for flexibility and can be used for upflow, horizontal, or downflow (kits required and manufactured and mobile home) applications. These units are designed specifically for Puron (R-410A) and must be used only with Puron air conditioners and heat pumps as shipped.

These units are designed to meet the low air leak requirements currently in effect. Because of this, the units need special attention in the condensate pan and drain connection area and when brazing tubing.

These units are available for application in systems of 24,000 through 60,000 Btuh nominal cooling capacities. Factory-authorized, field-installed electric heater packages are available in 5 through 30 kw. See Product Data for available accessory kits.

INSTALLATION

PROCEDURE 1—CHECK EQUIPMENT

Unpack unit and move to final location. Remove carton taking care not to damage unit.

Inspect equipment for damage prior to installation. File claim with shipping company if shipment is damaged or incomplete. Locate unit rating plate which contains proper installation information. Check rating plate to be sure unit matches job specifications.

PROCEDURE 2—MOUNT FAN COIL

Unit can stand or lie on floor, or hang from ceiling or wall. Allow space for wiring, piping, and servicing unit.

IMPORTANT: When unit is installed over a finished ceiling and/or living area, building codes may require a field-supplied secondary condensate pan to be installed under the entire unit. Some localities may allow the alternative of running a separate, secondary condensate line. Consult local codes for additional restrictions or precautions.

When installing any fan coil over a finished ceiling and/or living area, installation of a secondary drain pan under entire unit to avoid damage to ceiling is recommended.

FV4B Fan Coils can be installed for upflow and horizontal-left applications as factory shipped. (See Fig. 2, 4 and 8.) Units can be installed for horizontal-right applications with field modifications. Units may be converted for downflow applications using factory-authorized accessory kits.

NOTE: To ensure proper drainage for horizontal installations, unit must be installed so it is within 1/8 in. level of the length and width of unit.

A. Upflow Installation

If return air is to be ducted, install duct flush with floor. Set unit on floor over opening.

Only use return-air opening provided. All return air must pass through the coil. (See Fig. 2.)

B. Modular Units

The FV4B Fan Coil in size 006 is a 2-piece modular unit. Modular construction allows installer to disassemble unit into 2 components, coil box and blower box, for ease of installation. (See Fig. 3.)

To disassemble unit, remove rear corner brackets by removing 2 screws which secure brackets. (See Fig. 3.) Remove either 2 screws in each front corner of coil box, or 2 screws in blower box. Do not remove all 4 screws in each corner. (See Fig. 3.) Sections may now be separated by lifting top section from lower section.

To reassemble, reverse above procedure. Be certain to reinstall all fasteners when reassembling.

C. Horizontal Installations

Be sure installation complies with all applicable building codes that may require installation of a secondary condensate pan.

1. Arrange support for unit by setting it in or above secondary condensate pan.
2. When suspending unit from ceiling dimples in casing indicate proper location of screws for mounting metal support straps. (See Fig. 4.)

D. Horizontal-Right Conversion of Units with Slope Coils

NOTE: Gasket kit number KFAHD0101SLP is required for horizontal slope coil conversion to maintain low air leak/low sweat performance.

1. Remove blower and coil access panels and fitting panel. (See Fig. 5.)
2. Remove screw securing coil assembly to right side casing flange.
3. Remove coil assembly.
4. Lay fan coil on its right side and reinstall coil assembly with condensate pan down. (See Fig. 5.)
5. Attach coil to casing flange using previously removed coil mounting screw.
6. Make sure the pan cap in the fitting door is properly seated on the fitting door to retain the low air leak rating of the unit.
7. Add gaskets from kit KFAHD per kit instructions.
8. Reinstall access panels and fitting panel, aligning holes with tubing connections and condensate pan connections.

Make sure liquid and suction tube grommets are in place to prevent air leaks and cabinet sweating. Install grommets after brazing.

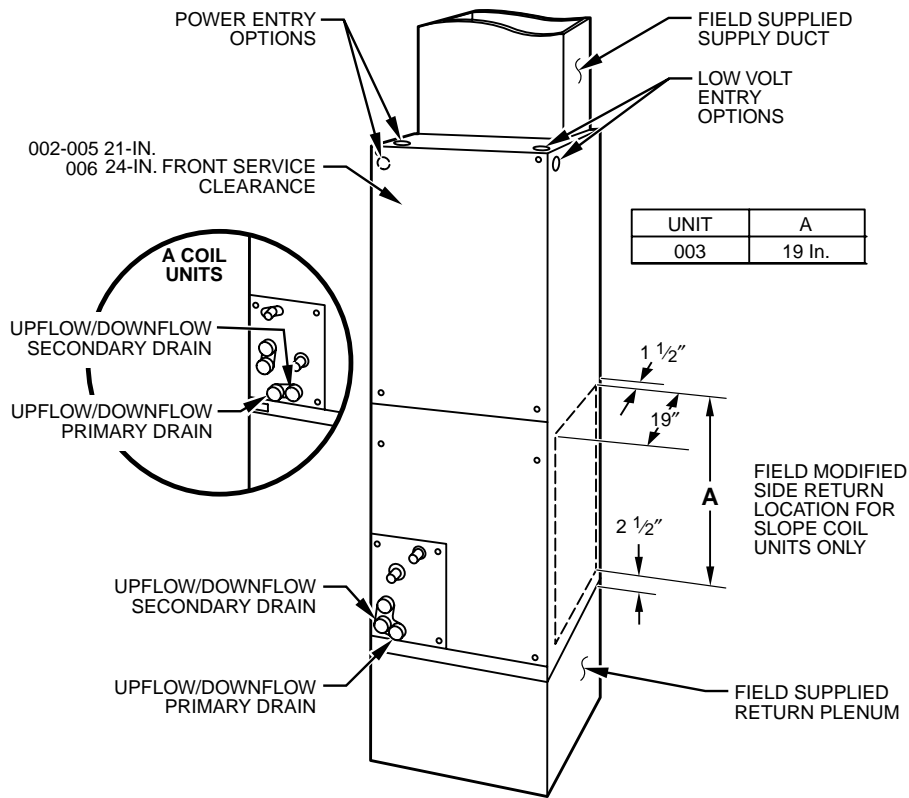

A00091

Fig. 2—Slope Coil Unit in Upflow Application

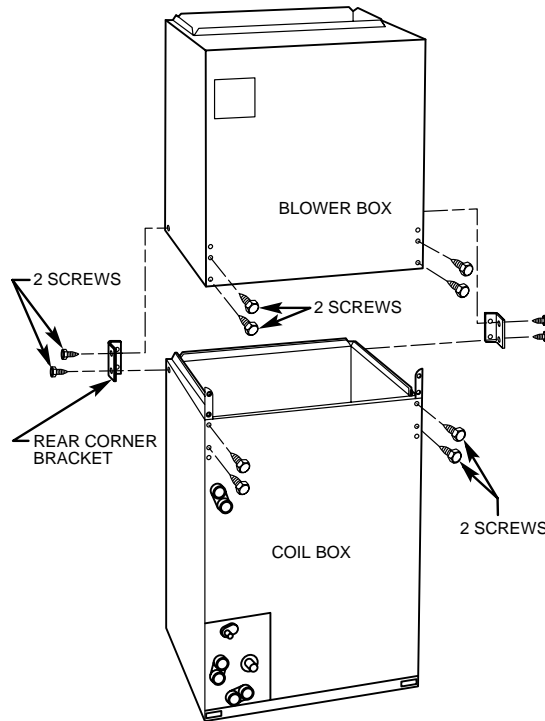

A95293

Fig. 3—Modular Unit Assembly

E. Horizontal Right Conversion of Units With A-Coil

To convert units for horizontal right installations:

1. Remove blower and coil access panels. (See Fig. 6.)
2. Remove metal clip securing fitting panel to condensate pan. Remove fitting panel.
3. Remove 2 snap-in clips securing A-coil in unit.
4. Slide coil and pan assembly out of unit.
5. Remove horizontal drain pan support bracket from coil support rail on left side of unit and reinstall on coil support rail on right side of unit.

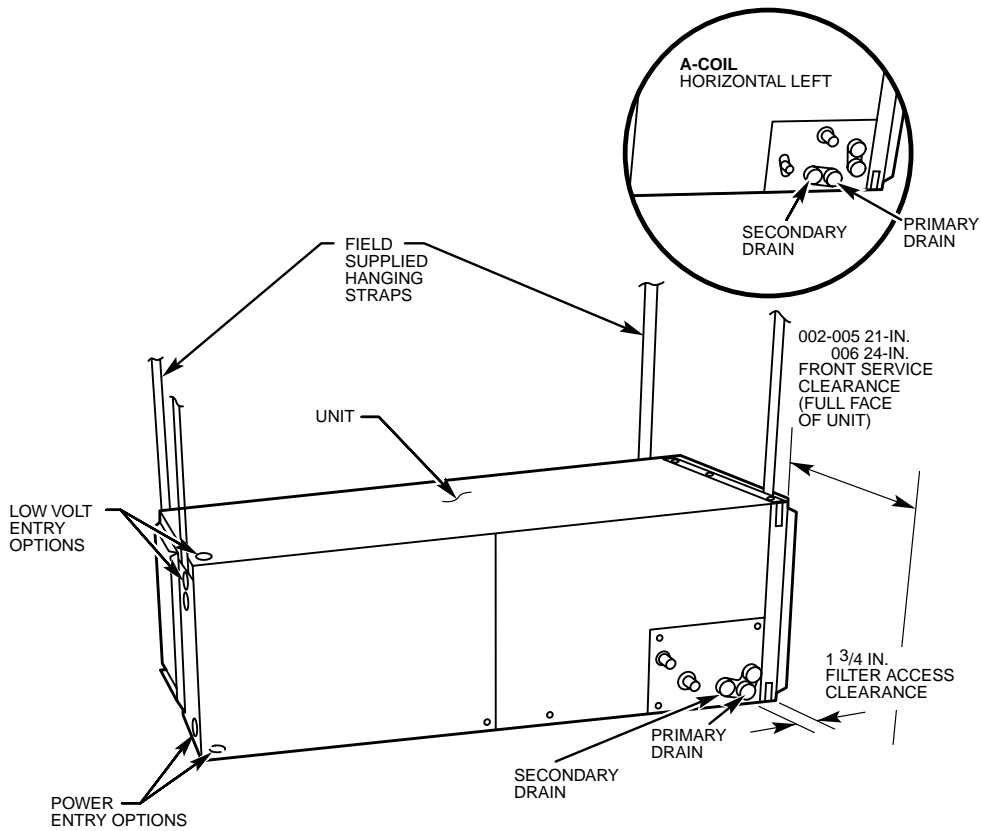

A00096

Fig. 4—Slope Coil in Horizontal-Left Application (Factory Ready)

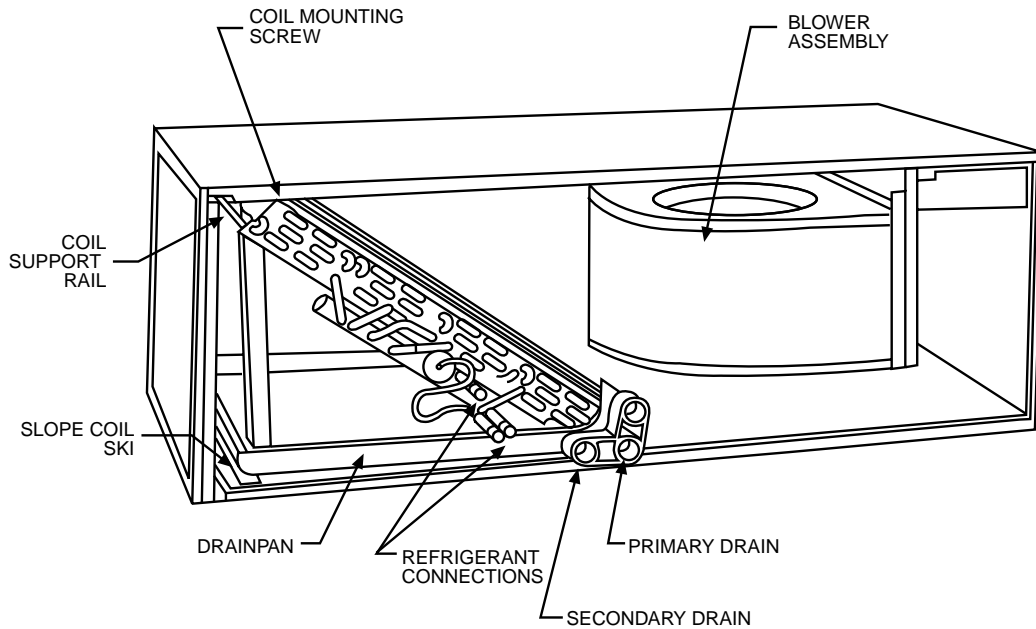

A03001

Fig. 5—Slope Coil in Horizontal Right Application

6. Convert air-seal assembly for horizontal right.
 - a. Remove air-seal assembly from coil by removing 4 screws. (See Fig. 6.)
 - b. Remove air splitter (B) from coil seal assembly by removing 3 screws. (See Fig. 6-factory-shipped inset.)
 - c. Remove filler plate (A) and install air splitter (B) in place of filler plate.
 - d. Install filler plate (A) as shown in horizontal right application.
 - e. Remove condensate troughs (C) and install on opposite tube sheets.
 - f. Install hose onto plastic spout.
7. Install horizontal pan on right side of coil assembly.

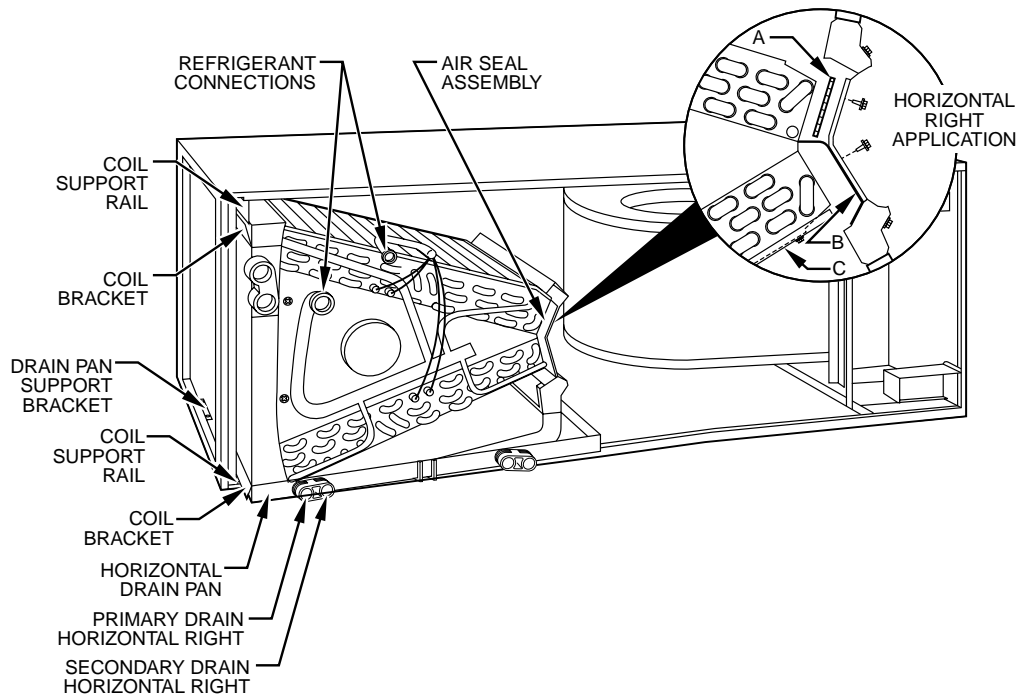

A00071

Fig. 6—A-Coil in Horizontal-Right Application

8. Slide coil assembly into casing. Be sure coil bracket on each corner of vertical pan engages coil support rails.
9. Reinstall 2 snap-in clips to correctly position and secure coil assembly in unit. Be sure clip with large offset is used on right side of unit to secure horizontal pan.
10. Remove two oval fitting caps from left side of the coil, access panel, and fitting panel.
11. Remove insulation knockouts on right side of coil access panel
12. Remove 2 oval coil access panel plugs and reinstall into holes on left side of coil access panel and fitting panel.
13. Install condensate pan fitting caps (from Step 10) in the right side of the coil door making sure that the cap snaps and seats cleanly on the back side of the coil door. Make sure no insulation interferes with seating of the cap.
14. Reinstall access and fitting panels, aligning holes with tubing connections and condensate pan connections. Be sure to reinstall metal clip between fitting panel and vertical condensate pan.

Make sure liquid and suction tube grommets are in place to prevent air leaks and cabinet sweating.

F. Downflow Installations

⚠ CAUTION: The conversion of the fan coil to downflow requires special procedures for the condensate drains on both A coil and Slope units. The vertical drains have an overflow hole between the primary and secondary drain holes. This hole is plugged for all applications except downflow, but must be used for downflow. During the conversion process, remove the plastic cap covering the vertical drains only and discard. Remove the plug from the overflow hole and discard. At completion of the downflow installation, caulk around the vertical drain fitting to door joint to retain the low air leak performance of the unit. Failure to follow this CAUTION could result in personal injury or product and property damage.

In this application, field conversion of the evaporator is required using accessory downflow kit along with an accessory base kit. Use fireproof resilient gasket, 1/8- to 1/4-in. thick, between duct, unit, and floor.

NOTE: To convert units for downflow applications, refer to Installation Instructions supplied with kit for proper installation. For slope fan coils, use kit Part No. KFADC0201SLP. For A fan coils use kit Part No. KFADC0401ACL. Use fireproof resilient gasket, 1/8- to 1/4-in. thick, between duct, unit, and floor.

NOTE: Gasket kit number KFAHD0101SLP is also required for all downflow applications to maintain low air leak/low sweat performance.

G. Manufactured and Mobile Home Housing Applications

1. Fan coil unit must be secured to the structure using field-supplied hardware.
2. Allow a minimum of 24" clearance from access panels.
3. Recommended method of securing for typical applications
 - a. If fan coil is away from wall, attach pipe strap to top of fan coil using No. 10 self tapping screws. Angle strap down and away from back of fan coil, remove all slack, and fasten to wall stud of structure using 5/16-in. lag screws. Typical both sides of fan coil.
 - b. If fan coil is against wall, secure fan coil to wall stud using 1/8-in. thick right-angle brackets. Attach brackets to fan coil using No. 10 self tapping screws and to wall stud using 5/16-in. lag screws. (See Fig. 7.)

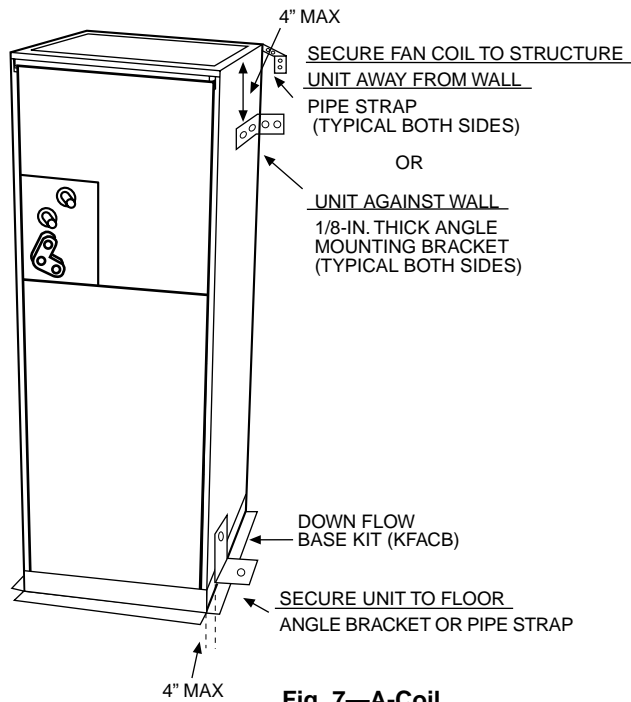

Fig. 7—A-Coil

A02003

PROCEDURE 3—AIR DUCTS

Connect supply-air duct over outside of 3/4-in. flange provided on supply-air opening. Secure duct to flange with proper fasteners for type of duct used, and seal duct-to-unit joint.

Duct connection flanges are provided on unit air discharge connection.

When using FV4B units with 20-, 24-, and 30-kw electric heaters, maintain a 1-in. clearance from combustible materials to discharge plenum and ductwork for a distance of 36 in. from unit. Use accessory downflow base to maintain proper clearance on downflow installations.

Use flexible connectors between ductwork and unit to prevent transmission of vibration. When electric heater is installed, use heat resistant material for flexible connector between ductwork and unit at discharge connection. Ductwork passing through unconditioned space must be insulated and covered with vapor barrier.

Ductwork Acoustical Treatment

Metal duct systems that do not have a 90° elbow and 10 ft of main duct to first branch takeoff may require internal acoustical insulation lining. As an alternative, fibrous ductwork may be used if constructed and installed in accordance with the latest edition of SMACNA construction standard on fibrous glass ducts. Both acoustical lining and fibrous ductwork shall comply with National Fire Protection Association Standards 90A or B as tested by UL Standard 181 for Class 1 air ducts.

PROCEDURE 4—ELECTRICAL CONNECTIONS

On units with a factory installed disconnect with pull-out removed, service and maintenance can be safely performed on only the load side of the control package.

⚠ WARNING: Field wires on the line side of the disconnect found in the fan coil unit remain live, even when the pull-out is removed. Service and maintenance to incoming wiring can not be performed until the main disconnect switch (remote to the unit) is turned off. Failure to do so will result in electrical shock causing personal injury or death.

A. Line-Voltage Connections

If unit contains an electric heater, remove and discard power plug from fan coil and connect male plug from heater to female plug from unit wiring harness. (See Electric Heater Installation Instructions.)

For units without electric heat:

1. Connect 208/230v power leads from field disconnect to yellow and black stripped leads.
2. Connect ground wire to unit ground lug.

Check all factory wiring per unit wiring diagram and inspect factory wiring connections to be sure none were loosened in transit or installation.

⚠ WARNING: Before installing or servicing system, always turn off all power to system. There may be more than 1 disconnect switch. Turn off accessory heater power if applicable. Electrical shock can cause personal injury or death.

⚠ WARNING: If a disconnect switch is to be mounted on the unit, select a location where drill or fastener will not contact electrical or refrigerant components. Electrical shock can cause personal injury or death.

NOTE: Before proceeding with electrical connections, make certain that supply voltage, frequency, and phase are as specified on unit rating plate. Be sure that electrical service provided by the utility is sufficient to handle the additional load imposed by this equipment. See unit wiring label for proper field high- and low-voltage wiring. Make all electrical connections in accordance with NEC and any local codes or ordinances that may apply. Use copper wire only. The unit must have a separate branch electric circuit with a field-supplied disconnect switch located within sight from, and readily accessible from the unit.

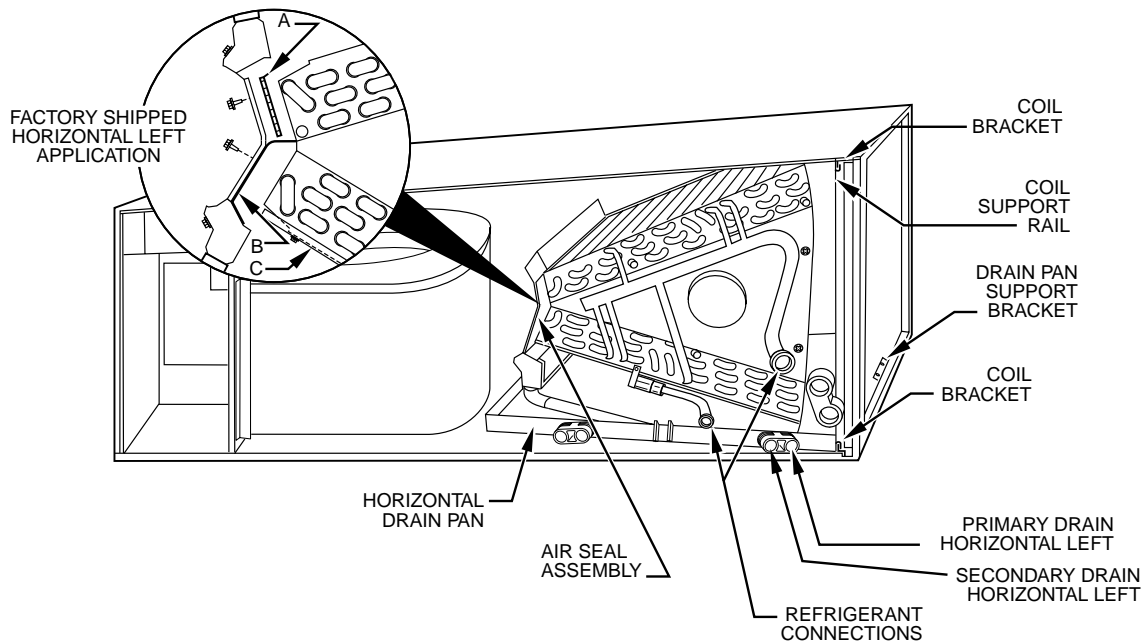

A00072

Fig. 8—A-Coil in Horizontal Left Application (Factory Ready)

B. 24-V Control System Connections to Unit Printed-Circuit Board (PCB)

Refer to unit wiring instructions for recommended wiring procedures. Use No. 18 AWG color-coded, insulated (35°C minimum) wires to make low-voltage connections between thermostat and unit. If thermostat is located more than 100 ft from unit (as measured along the low-voltage wires), use No. 16 AWG color-coded, insulated (35°C minimum) wires. PCB is circuited for single-stage heater operation. When additional heater staging is desired using outdoor thermostats or Intelligent Heat Staging, remove Jumper J2 on PCB to enable staging.

Connect low-voltage leads to thermostat and outdoor unit. (See Fig. 9, 10, 11, or 12.)

C. Intelligent Heat Staging Option

Intelligent Heat staging of the electric heat package is possible when the FV4B is installed as a part of a single-speed heat pump system using a corporate 2-speed programmable thermostat (model TSTATXXP2S01-B), Thermidistat™ Control, or capable zoning control and any 1 of the following electric heat packages:

Relay heaters KFCEH1401N09, KFCEH1501F15, KFCEH1701C15, KFCEH1801F20, KFCEH1901C20, KFCEH2101F24, OR KFCEH2201F30. Complete system low-voltage wiring as shown in Fig. 9, 10, 11, or 12.

NOTE: Where local codes require thermostat wiring be routed through conduit or raceways, splices can be made inside the fan coil unit. All wiring must be NEC Class 1 and must be separated from incoming power leads.

A factory-authorized disconnect kit is available for installation of 0- through 10-kw applications. When electric heat packages with circuit breakers are installed, the circuit breaker can be used as a disconnect. Transformer is factory wired for 230-v operation. For 208-v applications, disconnect black wire from 230-v terminal on transformer and connect it to 208-v terminal. (See Fig. 13.)

The secondary circuit of transformer is protected by a 5-amp fuse mounted on printed-circuit board.

IMPORTANT: Do not use outdoor thermostat with Intelligent Heat Staging.

→ **D. Manufactured Housing**

In manufactured housing applications, the Code of Federal Regulations, Title 24, Chapter XX, Part 3280.714 requires that supplemental electric heat be locked out at outdoor temperatures above 40 deg. F. except for a heat pump defrost cycle. A corporate thermostat in conjunction with an outdoor sensor can be used to lock out supplemental heat above 40 deg. F. Refer to thermostat instructions for details. If a non-corporate thermostat is used, an outdoor thermostat may be required.

E. Ground Connections

⚠ WARNING: The cabinet must have an uninterrupted or unbroken ground according to NEC, ANSI/NFPA 70 and local codes to minimize personal injury if an electrical fault should occur. The ground may consist of electrical wire or metal conduit when installed in accordance with existing electrical codes. (See Ground/Conduit Note below.) Failure to follow this warning could result in an electrical shock, fire, or death.

NOTE: Use UL listed conduit and conduit connector to connect supply wire(s) to unit and obtain proper grounding. If conduit connection uses reducing washers, a separate ground wire must be used. Grounding may also be accomplished by using grounding lug provided in control box. Use of dual or multiple supply circuits will require grounding of each circuit to ground lugs provided on unit and heaters.

PROCEDURE 5—REFRIGERANT TUBING CONNECTION AND EVACUATION

Use accessory tubing package or field-supplied tubing of refrigerant grade. Insulate entire suction tube if field-supplied tubing is used. Tubing package has an insulated suction tube. Do not use damaged, dirty, or contaminated tubing because it may plug refrigerant flow control device. When tubing package is used and sweat connections are made within 60 sec, coil and tubing system does not require evacuation. Always evacuate coil and field-supplied tubing to 500 microns before opening outdoor unit service valves.

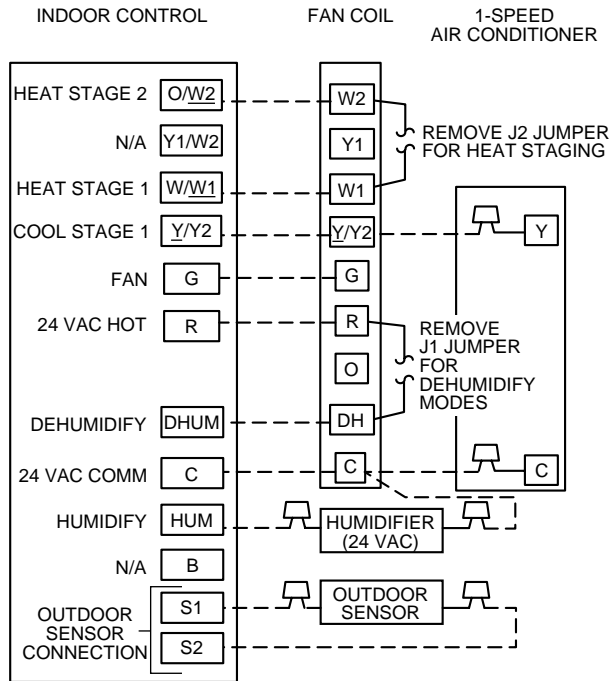

A98477

Fig. 9—FV4B Fan Coil Wiring with 1-Speed Air Conditioner

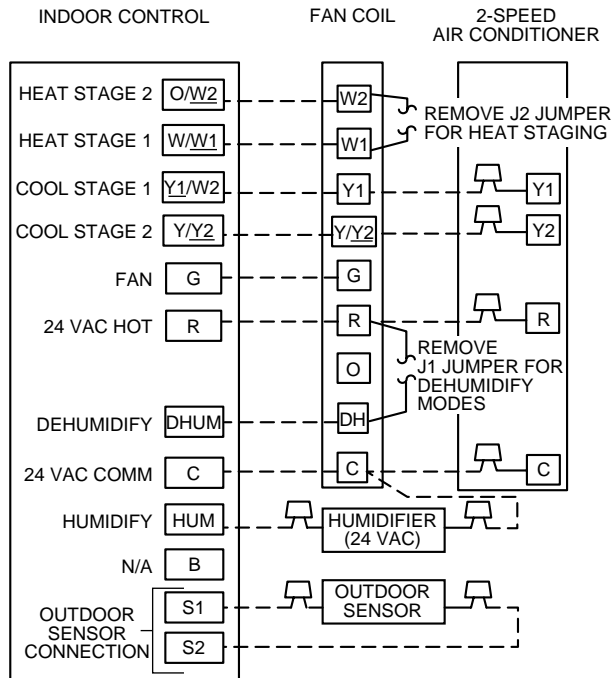

A98478

Fig. 10—FV4B Fan Coil Wiring with 2-Speed Air Conditioner

⚠ CAUTION: A brazing shield MUST be used when tubing sets are being brazed to the unit connections to prevent damage to the unit surface and condensate pan fitting caps. Failure to follow this CAUTION could result in minor personal injury or product and property damage.

Units have sweat suction and liquid tube connections. Make suction tube connection first.

1. Cut tubing to correct length.
2. Insert tube into sweat connection on unit until it bottoms.
3. Braze connection using silver bearing or non-silver bearing brazing materials. Do not use solder (materials which melt below 800°F). Consult local code requirements.

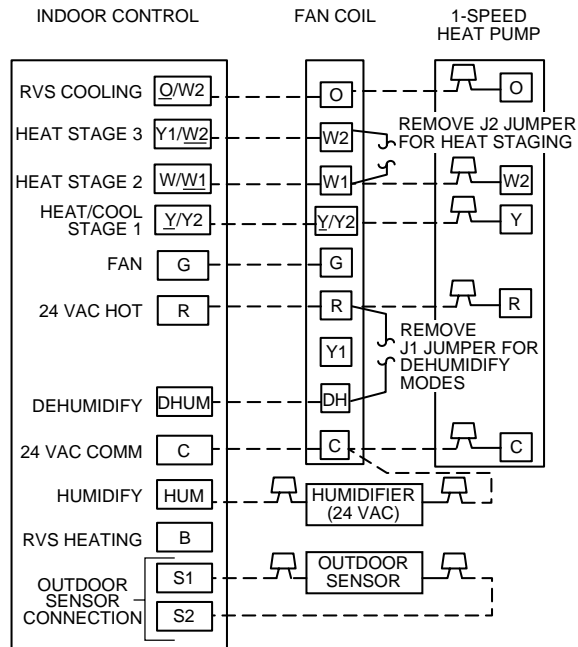

A98475

Fig. 11—FV4B Fan Coil Wiring with 1-Speed Heat Pump

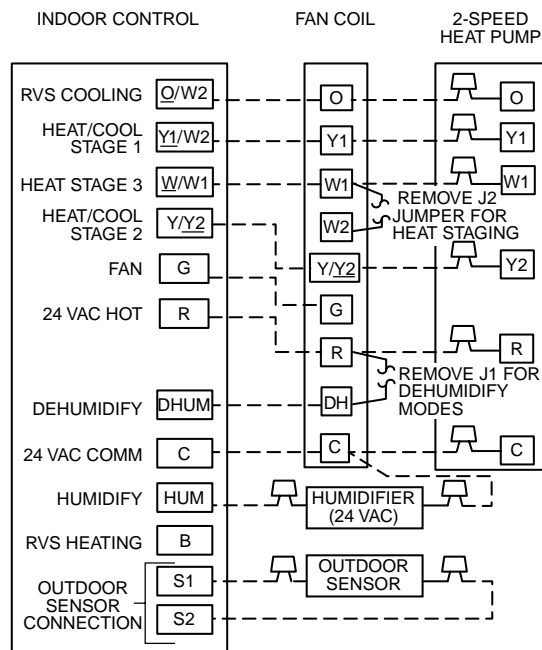

A02005

Fig. 12—FV4B Fan Coil Wiring with 2-Speed Puron Heat Pump

⚠ CAUTION: Wrap a wet cloth around rear of fitting to prevent damage to TXV and factory-made joints. Failure to follow this CAUTION could result in minor personal injury or product and property damage.

4. Evacuate coil and tubing system to 500 microns using deep vacuum method.

PROCEDURE 6—CONDENSATE DRAIN

To connect drains the cap openings must be removed. Use a knife to start the opening near the tab and using pliers, pull the tab to remove the disk. Clean the edge of the opening if necessary and install the condensate line. Finally caulk around the lines where they exit the fitting to retain the low leak rating of the unit.

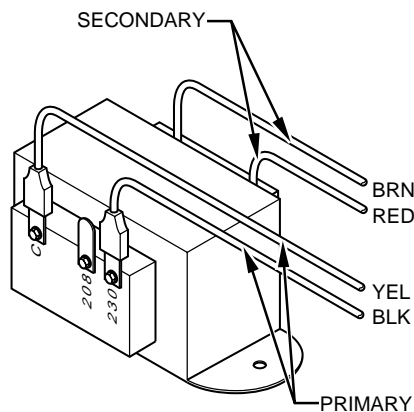

Fig. 13 - Transformer Connections

A94067

CAUTION: The conversion of the fan coil to downflow requires special procedures for the condensate drains on both A coil and Slope units. The vertical drains have an overflow hole between the primary and secondary drain holes. This hole is plugged for all applications except downflow, but must be used for downflow. During the conversion process, remove the plastic cap covering the vertical drains only and discard. Remove the plug from the overflow hole and discard. At completion of the downflow installation, caulk around the vertical pan fitting to door joint to retain the low air leak performance of the unit. Failure to follow this CAUTION could result in minor personal injury or product and property damage.

Units are equipped with primary and secondary 3/4-in. FPT drain connections. For proper condensate line installation see Fig. 2, 4, 5, 6, and 8. To prevent property damage and achieve optimum drainage performance, BOTH primary and secondary drain lines should be installed and include properly-sized condensate traps. (See Fig. 14 and 16.) Factory-approved condensate traps are available. Be sure to install plastic push-in plugs in unused condensate drain fittings. It is recommended that PVC fittings be used on the plastic condensate pan. Do not over-tighten. Finger-tighten plus 1-1/2 turns. Use pipe dope.

CAUTION: Shallow running traps are inadequate and DO NOT allow proper condensate drainage. (See Fig. 15.) Failure to follow this CAUTION could result in minor personal injury or product and property damage.

NOTE: When connecting condensate drain lines avoid blocking filter access panel. Prime both primary and secondary condensate traps after connecting to drain pan.

NOTE: If unit is located in or above a living space where damage may result from condensate overflow, a field-supplied external condensate pan should be installed underneath the entire unit, and a secondary condensate line (with appropriate trap) should be run from the unit into the pan. Any condensate in this external condensate pan should be drained to a noticeable place. As an alternative to using an external condensate pan, some localities may allow the use of a separate 3/4-in. condensate line (with appropriate trap) to a place where the condensate will be noticeable. The owner of the structure must be informed that when condensate flows from the secondary drain or external condensate pan, the unit requires servicing, or water damage will occur.

Install traps in the condensate lines as close to the coil as possible. (See Fig. 16.) Make sure that the outlet of each trap is below its connection to the condensate pan to prevent condensate from overflowing the drain pan. Prime all traps, test for leaks, and insulate traps if located above a living area.

Condensate drain lines should be pitched downward at a minimum of 1 in. for every 10 ft. of length. Consult local codes for additional restrictions or precautions.

CAUTION: Never operate unit without a filter or with filter access door removed. Damage to blower motor or coil can result. Failure to follow this CAUTION could result in minor personal injury or product and property damage.

IMPORTANT: Factory authorized filters must be used when locating the filter inside the unit. (See Table 1.) For those applications where access to an internal filter is impractical, a field-supplied filter must be installed in the return duct system.

PROCEDURE 7—UNIT START-UP

Refer to outdoor unit Installation Instructions for system start-up instructions and refrigerant charging method details.

PROCEDURE 8—EASY SELECT CONFIGURATION TAPS

Easy Select™ taps are used by the installer to configure a system. The ECM motor uses the selected taps to modify its operation to a pre-programmed table of airflows. (See Table 3 and 4.) Airflows are based on system size or mode of operation and those airflows are modified in response to other inputs such as the need for de-humidification. (See Fig. 17 and 18.)

The FV4B Fan Coil must be configured to operate properly with system components with which it is installed. To successfully configure a basic system (see information printed on circuit board label located next to select pins), move the 6 select wires to the pins which match the components used.

A. AUX HEAT KW/CFM - Select heater range for size of electric heater installed

Installer must select the auxiliary heat airflow approved for application with kw size heater installed. If no heater is installed, this step can be skipped. Each select pin is marked with a range of heaters for which airflow, also marked, is approved. For increased comfort select the narrowest kw range matching the heater size, for example, 0-10 for 10-kw heater. This airflow must be greater than the minimum CFM for electric heater

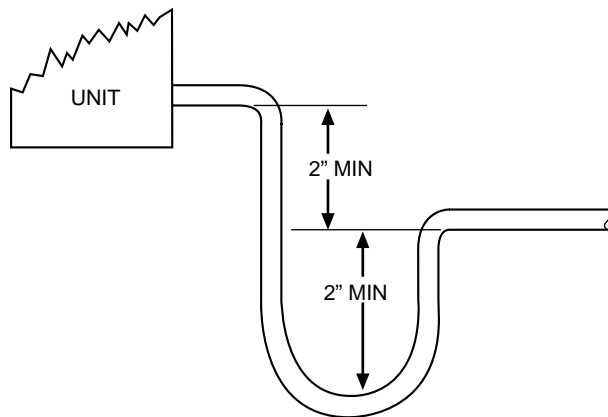

A03002

Fig. 14—Recommended Condensate Trap

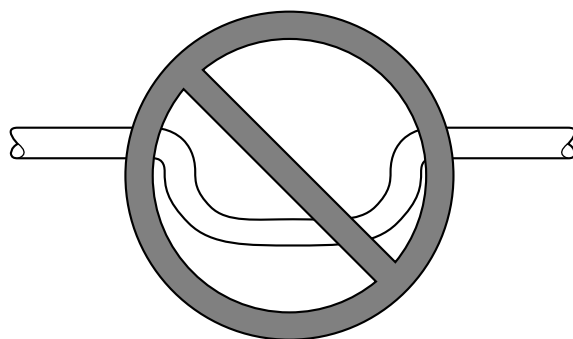

DO NOT USE SHALLOW RUNNING TRAPS!

A03013

Fig. 15—Insufficient Condensate Trap

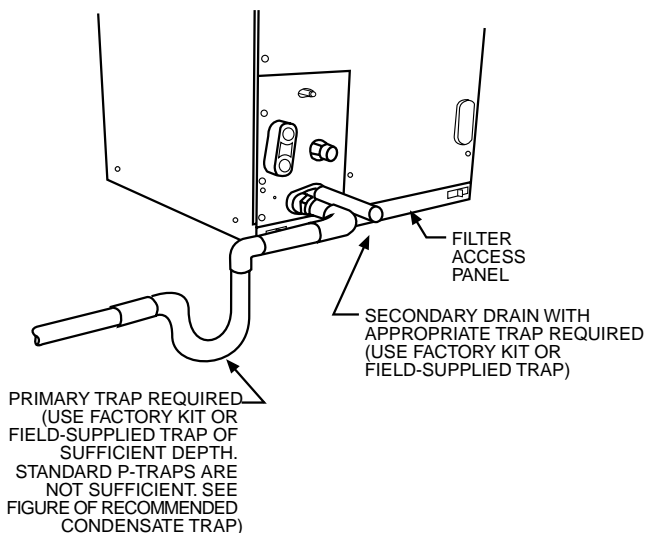

A03003

Fig. 16—Condensate Trap and Unit

application with the size system installed for safe and continuous operation. (See Table 5 and 6 for airflow delivery and minimum CFM.) Note that airflow marked is the airflow which will be supplied in emergency heat mode and heating mode on air conditioners when electric heat is the primary heating source. In heat pump heating mode when electric heaters are energized, the ECM motor will run the higher of heat pump heating airflow and electric heater airflow to ensure safe heater operation. The factory selection is the largest heater range approved. (See Fig. 17, A as indicated.)

B. AC/HP SIZE - Select system size installed

The factory setting for air conditioner or heat pump size is the largest unit meant for application with the model of fan coil purchased. Installer needs to select air conditioner or heat pump size to ensure that airflow delivered falls within proper range for the size unit installed. This applies to all operational modes with the exception of electric heat modes. (See Fig. 17, B as indicated.)

Table 1—Filter Kits

| FILTER KIT (12 PACK) | PART NUMBER | SIZE USED WITH |
|-------------------------|--------------|----------------|
| | KFAFK0212MED | 002, |
| | KFAFK0312LRG | 003, 005 |
| | KFAFK0412XXL | 006 |

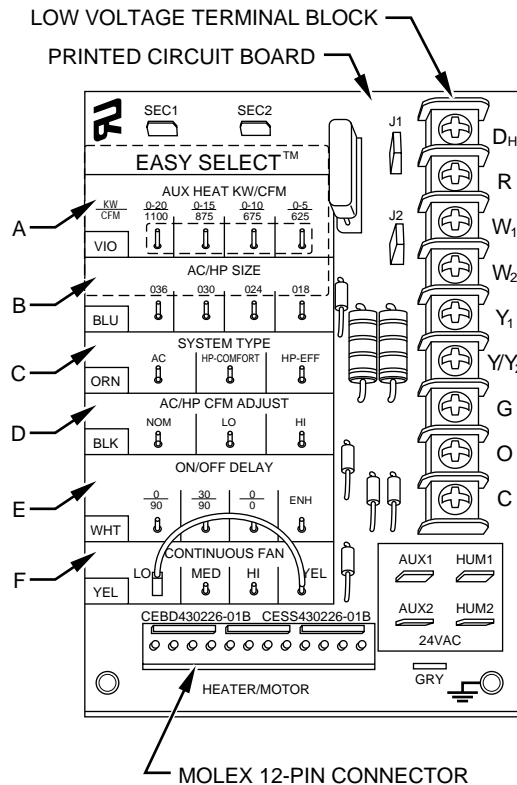

Fig. 17—Detail of FV4B Printed-Circuit Board

A95275

C. SYSTEM TYPE - Select system type installed AC or HP

The type of system must be selected:

1. AC - Air conditioner
2. HP-COMFORT - Heat Pump Comfort provides approximately 315 CFM per ton for higher normal heating air delivery temperature. Provides approximately 350 CFM per ton cooling airflow for good humidity removal.
3. HP-EFF - Heat Pump Efficiency provides same airflow for heating and cooling modes to increase overall HP efficiency; approximately 350 CFM per ton.

The factory setting is AC. (See Fig. 17, C as indicated.)

D. AC/HP CFM ADJUST - Select Medium, Low, or High Airflow

To provide airflow at rates described above, the AC/HP ADJUST select is factory set to the nominal (nom) tap. The adjust selections HI/LO will regulate airflow supplied for all operational modes, except non-heat pump heating modes. HI provides 15 percent airflow over nominal unit size selected and LO provides 10 percent airflow below nominal unit size selected. Adjust selection options are provided to adjust airflow supplied to meet individual installation needs for such things as noise, comfort, and humidity removal. (See Fig. 17, D as indicated.)

E. ON/OFF DELAY - Select desired time delay profile

NOTE: Delay selections are active in cooling and heat pump heating modes only. Auxiliary heating modes have a 1 minute off delay and zero on delay programmed into the ECM motor that cannot be overridden.

Four motor operation delay profiles are provided to customize and enhance system operation. (See Fig. 17, E as indicated)

Selection options are:

1. The standard 90 sec off delay (Factory setting) at 100 percent airflow.
2. No delay option used for servicing unit or when a thermostat is utilized to perform delay functions.
3. A 30 sec on delay with no airflow/90 sec off delay at 100 percent airflow profile is used when it is desirable to allow system coils time to heat-up/cool-down in conjunction with the airflow.
4. ENH, enhanced selection, provides a 30 sec on delay with no airflow/ plus 150 sec at 70 percent airflow/ no off delay for added comfort. This profile will minimize cold blow in heat pump operation and could enhance system efficiency.

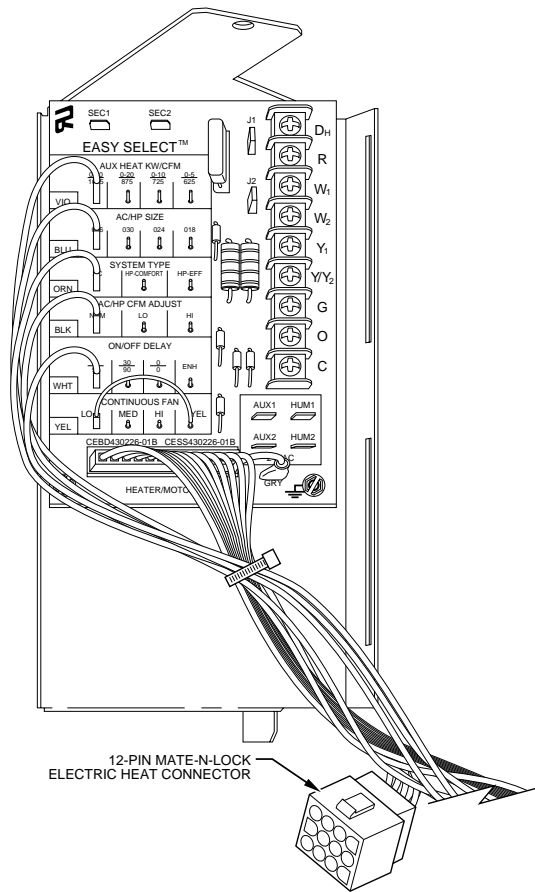

A95275

Fig. 18—PCB Wiring Arrangement

F. CONTINUOUS FAN - Select desired fan speed when thermostat is set on continuous fan

NOTE: If installed with a 2-speed outdoor unit, do not select HI speed continuous fan. If HI is selected, low speed compression will also run HI speed possibly resulting in insufficient dehumidification.

1. LO speed - factory setting, 50 percent cooling mode airflow.
2. MED speed - move connector to MED, 65 percent cooling mode airflow.
3. HI speed - move connector of HI, 100 percent cooling mode airflow. (See Fig. 17, F as indicated.)

G. Low-Voltage Circuit Fusing and Reference

The low-voltage circuit is fused by a board-mounted 5-amp automotive fuse placed in series with the transformer SEC2 and the R circuit. The C circuit of the transformer is referenced to chassis ground through a printed circuit run at SEC1 connected to metal standoff marked with ground symbol.

H. Basic Fan Coil Configuration

The following basic configuration of the fan coil will provide ARI rated performance of the heat pump:

1. AUX HEAT KW/CFM - Select the heater range for the size electric heater installed.
2. AC/HP SIZE - Select system size installed.
3. SYSTEM TYPE - Select system type HP-EFF.
4. AC/HP CFM ADJUST - Select NOM.
5. ON/OFF DELAY - Select 0/90 profile.
6. CONTINUOUS FAN - Select desired fan speed when thermostat is set to continuous fan.

I. COMFORT OPTIONS - WARMER HEATING AND SUPER DEHUMIDIFY (See Fig. 21 for Quick Reference Guide)

The FV4B Fan Coil provides better than average humidity control and heated air temperature. This configuration will improve the comfort provided by the heat pump system if more humidity removal or if warmer heating air is desired. While providing this improved comfort, the heat pump system will operate efficiently, but not at the published HSPF or ARI SEER efficiency.

The following fan coil configuration is recommended for maximum heating and cooling/dehumidifying comfort: (See Fig. 17.)

1. AUX HEAT KW/CFM - Select narrowest heater range to match size of electric heater installed (skip this step if no heater is installed).
2. AC/HP SIZE - Select system size installed.

3. SYSTEM TYPE - Select system type HP-COMFORT (for heat pump system) or AC (for air conditioner system).
4. AC/HP CFM ADJUST - Select LO.
5. ON/OFF DELAY - Select ENH profile.
6. CONTINUOUS FAN - Select desired fan speed when thermostat is set to continuous fan.
7. If the fan coil is installed with Intelligent Heat Staging capable electric heaters, remove jumper J2. (See Fig. 17.)

NOTE: If configuring to run warmer heating, do not remove jumper J2 when using 5-, 8-, or 10-kw heaters.

8. Remove jumper J1 to activate dehumidify modes.
9. Wire low voltage connections as shown in Fig. 9, 10, 11, or 12.
10. Configure Thermidistat (or capable zoning system) following its installation instructions for enhanced dehumidification and SuperComfort/Perfect Heat operation.

This configuration provides the following comfort enhancements:

- a. A 30 second blower on delay with 150 seconds at 70 percent airflow to allow the indoor coil to warm up or cool down before the blower is asked to deliver 100 percent airflow reducing the cold blow sensation at start up in heating and allowing the indoor coil to more quickly reach wet coil operating conditions in cooling.
- b. No blower off delay eliminates cold blow which may be associated with running the blower after shut down of the compressor and avoids re-evaporation of condensed moisture after cooling/dehumidifying operation.
- c. Lower airflow while the compressor is running to reduce draft effects and increase heating air temperature and improved humidity control during cooling operation.
- d. Intelligent Staging of the electric heater elements to more closely match heating load requirements and provide more consistent heating air temperatures.

PROCEDURE 9—ACCESSORY INSTALLATION

A. Accessory Electric Heaters

Electric heaters may be installed with the FV4B Fan Coil per instructions supplied with electric heater package. See unit rating plate for factory-approved electric heater kits.

NOTE: Units installed without electric heat should have a field-supplied sheet metal block-off plate covering the heater opening. This reduces air leakage and formation of exterior condensation.

B. Auxiliary Terminals

The AUX and HUM terminals on the Easy Select Board are tied directly to the G terminal, and provide a 24-vac signal whenever the G terminal is energized. (See Fig. 17 and 18.) During Super Dehumidify and SuperComfort / Perfect Heat modes, the G signal is not present and the auxiliary terminals are not energized. If the installation includes the use of these operating modes, do not use these terminals to control accessories. See Electronic Air Cleaner and Humidifier sections for further information.

C. Electronic Air Cleaner Connections

The AUX1 and AUX2 terminals are not always energized during blower operation, as described above. When using an electronic air cleaner with the FV4B Fan Coil, use Airflow Sensor Part No. KEAAC0101AAA. The airflow sensor turns on electronic air cleaner when the fan coil blower is operating.

D. Humidifier/Humidistat Connections

Easy Select Board terminals HUM1 and HUM2 are provided for direct connection to the low-voltage control of a humidifier through a standard humidistat. (See Fig. 19.) These terminals are energized with 24vac when G thermostat signal is present. (See Fig. 20.) Alternately, the 24-vac signal may be sourced from the W and C terminal block connections when electric heaters are used as primary heating source. When using a Thermidistat™ Control, Zone Perfect *Plus* or Comfort Zone II, the 24-vac signal may be sourced directly from the Thermidistat HUM terminal. (See Fig. 9, 10, 11, and 12.)

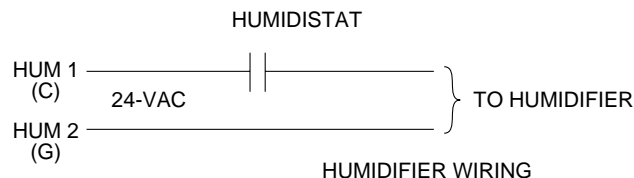

A95317

Fig. 19—Humidifier Wiring

E. Dehumidify Capability with Standard Humidistat Connection

Latent capacities for systems using the FV4B Fan Coil are better than average systems. If increased latent capacity is an application requirement, the field wiring terminal block provides connection terminals for use of a standard humidistat. The FV4B Fan Coil will detect the humidistat contacts opening on increasing humidity and reduce its airflow to approximately 80 percent of nominal cooling mode airflow. This reduction will increase the system latent capacity until the humidity falls to a level which causes the humidistat to close its contacts. When the contacts close, the airflow will return to 100 percent of the selected cooling airflow. To activate this mode, remove Jumper J1 and wire in a standard humidistat. (See Fig. 20.)

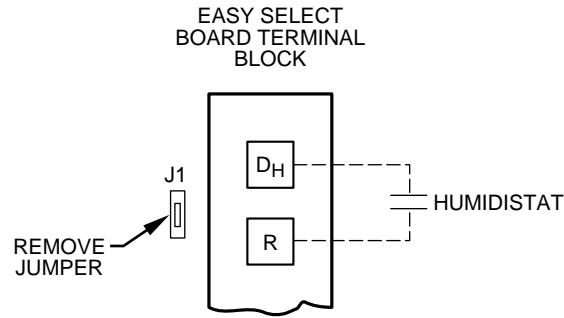

A95316

Fig. 20—Humidistat Wiring for De-Humidify Mode

F. Dehumidify and Super Dehumidify Capabilities

This model fan coil is capable of responding to a signal from indoor system control (Thermostat, zoning control) to operate in comfort control modes such as Super Dehumidify Mode. Consult literature provided with indoor system control to determine if these operating modes are available, and to see control set up instructions. No special setup or wiring of fan coil is required.

PROCEDURE 10—FV4B FAN COIL SEQUENCE OF OPERATION

The FV4B will supply airflow in a range which is more than twice the range of a standard fan coil. It is designed to provide nominal cooling capacities at a 50°F evaporator temperature and the required airflow which enables it to match with 4 air conditioner or heat pump system sizes. Table 2 outlines the CFM range for the different FV4B Fan Coil sizes.

A. Continuous Fan

- Thermostat closes circuit R to G.
- The blower runs at continuous fan airflow.

B. Cooling Mode - Single speed

- If indoor temperature is above temperature set point and humidity is below humidity set point, thermostat closes circuits R to G, R to Y/Y2 and R to O.
- The fan coil delivers single speed cooling airflow.

C. Cooling Mode - Dehumidification

- If indoor temperature is above temperature set point and humidity is above humidity set point, thermostat or Thermostat™ closes circuits R to G, R to O, and R to Y/Y2, and humidistat or Thermostat opens R to DH.
- The fan coil delivers airflow which is approximately 80 percent of the nominal cooling airflow to increase the latent capacity of the system.

D. Cooling Mode - Super Dehumidify Operation (See Fig. 22 for Quick Reference Guide)

NOTE: The indoor control used, such as Thermostat, must be capable of providing Super Dehumidify operation mode and control must be configured as outlined in its installation instructions. Consult indoor control literature to determine if control is capable of providing Super Dehumidify inputs and for configuration instructions.

If the indoor temperature is below the temperature set point and the humidity is above the humidity set point, the Thermostat closes circuit R to O, opens circuits R to DH and R to G, and cycles circuit R to Y/Y2 (for single speed system R to Y1, or R to Y1 and Y/Y2 for 2-speed system). The ECM motor reads the G signal to the fan coil while the heat pump is operating, (circuit R to Y/Y2 for single speed system, R to Y1 or R to Y1 and Y/Y2 for 2-speed system), closed (24 vac). If circuit R to G is closed (24 vac), the motor will deliver airflow at the full cooling or cooling plus dehumidify mode requested value. If circuit R to G is open (0 vac) for super dehumidify mode, the motor delivers reduced airflow to maximize the humidity removal of the system while minimizing overcooling.

E. Electric Heat Heating Mode

- Thermostat closes circuit R to W/W1, or W2.
- The fan coil delivers the selected electric heat airflow.

F. Heat Pump Heating Mode - Single speed

- Thermostat closes circuits R to G and R to Y/Y2.
- The fan coil delivers single speed heat pump heating airflow.

G. Heat Pump Heating with Auxiliary Electric Heat

Thermostat closes circuits R to G, R to Y/Y2 and/or R to Y1 with R to W/W1 or W2 (and R to O in the case of defrost).

In the event that electric heating is called for by the thermostat while the heat pump is also operating in either heating or defrost modes, the motor will modify its airflow output, if necessary, to provide an airflow which is defined as safe for the operation of the electric heater during heat pump operation. That airflow is the greater of the heat pump heating airflow and the electric heater only airflow.

PROCEDURE 11—TROUBLESHOOTING ECM MOTOR AND CONTROLS

⚠ CAUTION: High voltage is always present at motor. Disconnect power to unit before removing or replacing connectors or servicing motor. Wait at least 5 min after disconnecting power before opening motor. Failure to follow this CAUTION could result in minor personal injury or product and property damage.

Table 2—CFM Range for FV4B Units

| FAN COIL SIZE | SYSTEM SIZES | CFM RANGE |
|---------------|--------------------|-----------|
| FV4BNF002 | 024, 030, 036 | 450-1275 |
| FV4BNF003 | 024, 030, 036, 042 | 525-1475 |
| FV4BNF005 | 036, 042, 048 | 550-1700 |
| FV4BNB006 | 042, 048, 060 | 550-2150 |

Table 3—FV4B Fan Coil Airflow Delivery (CFM) in Cooling Mode

| UNIT SIZE | OUTDOOR UNIT CAPACITY | OPERATING MODE | | | | | | FAN ONLY LO/MED/HI |
|-----------|-----------------------|--------------------------|------------------------|-----------------------|------------------------|---------------------|------------------------|--------------------|
| | | Single-Speed Application | | Two-Speed Application | | | | |
| | | | | High Speed | | Low Speed | | |
| | | Nominal A/C Cooling | A/C Cooling Dehumidity | Nominal A/C Cooling | A/C Cooling Dehumidity | Nominal A/C Cooling | A/C Cooling Dehumidity | |
| 002 | 018 | 525 | 420 | — | — | — | — | 350/350/525 |
| | 024 | 700 | 560 | 735 | 590 | 440 | 350 | 350/440/700 |
| | 030 | 875 | 700 | — | — | — | — | 440/550/875 |
| | 036 | 1050 | 840 | 1100 | 880 | 660 | 530 | 525/660/1050 |
| 003 | 024 | 700 | 560 | 735 | 590 | 440 | 415 | 415/440/700 |
| | 030 | 875 | 700 | — | — | — | — | 440/550/875 |
| | 036 | 1050 | 840 | 1100 | 880 | 660 | 530 | 525/660/1050 |
| | 042 | 1225 | 980 | — | — | — | — | 610/770/1225 |
| 005 | 030 | 875 | 700 | — | — | — | — | 440/550/875 |
| | 036 | 1050 | 840 | 1100 | 880 | 660 | 530 | 525/660/1050 |
| | 042 | 1225 | 980 | — | — | — | — | 610/770/1225 |
| | 048 | 1400 | 1120 | 1470 | 1175 | 880 | 705 | 700/880/1400 |
| 006 | 036 | 1050 | 840 | 1100 | 880 | 660 | 530 | 525/660/1050 |
| | 042 | 1225 | 980 | — | — | — | — | 610/770/1225 |
| | 048 | 1400 | 1120 | 1470 | 1175 | 880 | 705 | 700/880/1400 |
| | 060 | 1750 | 1400 | 1835 | 1470 | 1100 | 880 | 875/1100/1750 |

NOTE

1. The above airflows result with the AC/HP CFM ADJUST select jumper set on NOM.
2. Airflow can be adjusted +15 percent or -10 percent by selecting HI or LO respectively for all modes except fan only.
3. Dry coil at 230 volts and with 10kw heater and filter installed.
4. Airflows shown are at standard air conditions.

Table 4—FV4B Fan Coil Airflow Delivery (CFM) in Heat Pump Only Heating Mode

| UNIT SIZE | OUTDOOR UNIT CAPACITY | OPERATING MODE | | | | | | FAN ONLY LO/MED/HI |
|-----------|-----------------------|--------------------------|----------------------|-----------------------|----------------------|-------------------|----------------------|--------------------|
| | | Single-Speed Application | | Two-Speed Application | | | | |
| | | | | High Speed | | Low Speed | | |
| | | Heat Pump Comfort | Heat Pump Efficiency | Heat Pump Comfort | Heat Pump Efficiency | Heat Pump Comfort | Heat Pump Efficiency | |
| 002 | 018 | 420 | 525 | — | — | — | — | 350/350/470 |
| | 024 | 560 | 700 | 660 | 735 | 395 | 440 | 350/395/630 |
| | 030 | 700 | 875 | — | — | — | — | 440/520/785 |
| | 036 | 840 | 1050 | 990 | 1100 | 595 | 660 | 525/595/945 |
| 003 | 024 | 560 | 700 | 660 | 735 | 415 | 440 | 415/415/630 |
| | 030 | 700 | 875 | — | — | — | — | 440/520/785 |
| | 036 | 840 | 1050 | 990 | 1100 | 595 | 660 | 525/595/945 |
| | 042 | 980 | 1225 | — | — | — | — | 610/695/1100 |
| 005 | 030 | 700 | 875 | — | — | — | — | 440/520/785 |
| | 036 | 840 | 1050 | 990 | 1100 | 595 | 660 | 525/595/945 |
| | 042 | 980 | 1225 | — | — | — | — | 610/695/1100 |
| | 048 | 1120 | 1400 | 1320 | 1470 | 795 | 880 | 700/795/1260 |
| 006 | 036 | 840 | 1050 | 990 | 1100 | 595 | 660 | 525/595/945 |
| | 042 | 980 | 1225 | — | — | — | — | 610/695/1100 |
| | 048 | 1120 | 1400 | 1325 | 1470 | 795 | 880 | 700/795/1260 |
| | 060 | 1400 | 1750 | 1655 | 1835 | 990 | 1100 | 875/990/1575 |

NOTE

1. The above airflows result with the AC/HP CFM ADJUST select jumper set on NOM.
2. Airflow can be adjusted +15 percent or -10 percent by selecting HI or LO respectively for all modes except fan only.
3. Dry coil at 230 volts and with 10kw heater and filter installed.
4. Airflows shown are at standard air conditions.

The ECM motor used with this product contains two parts: the control module and motor winding section. Do not assume the motor or module is defective if it will not start. Go through the steps described below before replacing control module, Easy Select Board or entire motor. The control module is available as a replacement part.

Table 5—FV4B Airflow Delivery (CFM)

| FAN UNIT SIZE | OUTDOOR UNIT CAPACITY BTUH | ELECTRIC HEATER KW RANGE | | | | | | | | | | | |
|---------------|----------------------------|--------------------------|------|------|------|------|------|------|------|------|------|------|------|
| | | 0-5 | | | 0-10 | | | 0-15 | | | 0-20 | | |
| | | LO | NOM | HI | LO | NOM | HI | LO | NOM | HI | LO | NOM | HI |
| 002 | 18,000 | 625 | 625 | 625 | 675 | 675 | 675 | * | * | * | * | * | * |
| | 24,000 | 650 | 725 | 835 | * | 725 | 835 | 875 | 875 | 875 | * | * | * |
| | 30,000 | 815 | 905 | 1040 | * | 905 | 1040 | 900 | 900 | 1040 | 1100 | 1100 | 1100 |
| | 36,000 | 980 | 1085 | 1250 | 980 | 1085 | 1250 | 980 | 1085 | 1250 | 1100 | 1100 | 1250 |
| 003 | 24,000 | 675 | 725 | 835 | 875 | 875 | * | * | * | * | * | * | * |
| | 30,000 | 815 | 905 | 1040 | 875 | 905 | 1040 | 1100 | 1100 | 1100 | * | * | * |
| | 36,000 | 980 | 1085 | 1250 | 980 | 1085 | 1250 | 1100 | 1100 | 1250 | 1225 | 1225 | 1250 |
| | 42,000 | 1140 | 1270 | 1460 | 1140 | 1270 | 1460 | 1140 | 1270 | 1460 | 1225 | 1270 | 1460 |
| FAN UNIT SIZE | OUTDOOR UNIT CAPACITY BTUH | ELECTRIC HEATER KW RANGE | | | | | | | | | | | |
| | | 0-10 | | | 0-15 | | | 0-20 | | | 0-30 | | |
| | | LO | NOM | HI | LO | NOM | HI | LO | NOM | HI | LO | NOM | HI |
| 005 | 30,000 | 975 | 975 | 1040 | 1100 | 1100 | 1100 | * | * | * | * | * | * |
| | 36,000 | 980 | 1085 | 1250 | 1100 | 1100 | 1250 | 1250 | 1250 | 1250 | * | * | * |
| | 42,000 | 1140 | 1270 | 1460 | 1140 | 1270 | 1460 | 1250 | 1270 | 1460 | * | * | * |
| | 48,000 | 1305 | 1450 | 1665 | 1305 | 1450 | 1665 | 1305 | 1450 | 1665 | 1500 | 1500 | 1665 |
| 006 | 36,000 | 1100 | 1100 | 1250 | 1350 | 1350 | 1350 | * | * | * | * | * | * |
| | 42,000 | 1140 | 1270 | 1460 | 1350 | 1350 | 1460 | 1525 | 1525 | 1525 | * | * | * |
| | 48,000 | 1305 | 1450 | 1665 | 1350 | 1450 | 1665 | 1525 | 1525 | 1665 | 1750 | 1750 | 1750 |
| | 60,000 | 1630 | 1810 | 2085 | 1630 | 1810 | 2085 | 1630 | 1810 | 2085 | 1750 | 1810 | 2085 |

* Airflow not recommended for heater/system size.
NOTE: LO, NOM, and HI refer to AC/HP CFM ADJUST selection.

Table 6—FV4B Minimum CFM for Electric Heater Application

| FAN COIL UNIT | HEAT PUMP UNIT SIZE | CFM | | | | |
|---------------|---------------------|----------------|----------|------|--------|--------|
| | | HEATER SIZE KW | | | | |
| | | 5 | 8, 9, 10 | 15 | 18, 20 | 24, 30 |
| 002 | Heater Only | 625 | 625 | 725 | 875 | — |
| | 018 | 625 | 625 | — | — | — |
| | 024 | 650 | 725 | 875 | — | — |
| | 030 | 800 | 875 | 875 | 1040 | — |
| | 036 | 970 | 970 | 970 | 1040 | — |
| 003 | Heater Only | 675 | 700 | 1050 | 1050 | — |
| | 024 | 675 | 875 | - | — | — |
| | 030 | 800 | 875 | 1100 | — | — |
| | 036 | 975 | 975 | 1100 | 1225 | — |
| | 042 | 1125 | 1125 | 1125 | 1225 | — |
| 005 | Heater Only | 675 | 700 | 1050 | 1050 | 1400 |
| | 030 | 800 | 875 | 1100 | — | — |
| | 036 | 975 | 975 | 1100 | 1225 | — |
| | 042 | 1125 | 1125 | 1125 | 1225 | — |
| | 048 | 1305 | 1305 | 1305 | 1305 | 1400 |
| 006 | Heater Only | 1050 | 1050 | 1050 | 1050 | 1750 |
| | 036 | 1100 | 1100 | 1350 | 1350 | — |
| | 042 | 1125 | 1125 | 1350 | 1350 | — |
| | 048 | 1300 | 1300 | 1350 | 1465 | 1750 |
| | 060 | 1625 | 1625 | 1625 | 1750 | 1750 |

NOTES:
1. Heater Only-Air conditioner with electric heater application.
2. These airflows are minimum acceptable airflows as UL listed. Actual airflow delivered will be per airflow delivery chart for Electric Heating Modes.

A. If motor turns slowly:

1. Replace panel. Motor may appear to run slowly if access panel is removed.
2. It is normal operation to run noticeably slower if G terminal is not energized in cooling or heat-pump modes.

B. If motor does not run:

Turn off power and check the following:

1. Check 5 amp fuse on Easy Select Board.
2. Check for 24vac on SEC1 and SEC2. If no voltage is present, check transformer.
3. Check all plugs and receptacles for any deformation which could cause loose connections. Be sure plugs are fully seated.

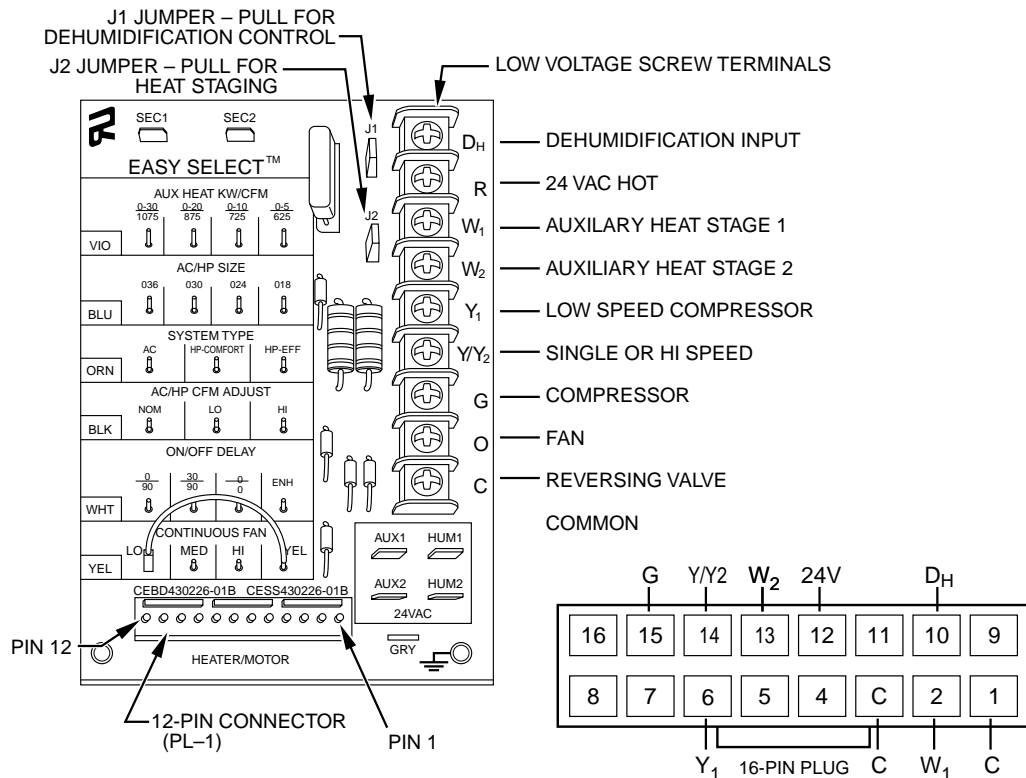

A03004

→ Fig. 21—Control Signals (Easy Select Board & 16-Pin Plug)

- Verify that approximately 230vac is present at motor.
- Verify low-voltage control signals to motor. The motor receives its control signals through the 12-pin plug (PL-1) on Easy Select Board and 16-pin plug on wiring harness. (See Troubleshooting Example.) The combinations of pins energized will determine motor speed. (See Fig. 20.) See Table 7 for circuit board, low-voltage screw terminals energized and for voltage present at each pin on 12-pin plug (PL-1). See Table 7 for pin number on 16-pin plug which should have voltage when Easy Select Board screw terminals have 24vac.

C. Use following procedure to check control signals:

THERMOSTAT

- Remove all thermostat wires from Easy Select Board.
- Jumper screw terminals (1 at a time): R-G, R-Y/Y₂, R-Y₁, R-W₁. If motor runs in all cases, thermostat is miswired, configured incorrectly or defective. If motor runs in some cases, but not others, continue to check wiring harness and circuit board.

WIRING HARNESS

- Shut off power to unit; wait 5 min.
- Remove 5-pin plug from motor.
- Remove 16-pin from motor.
- Replace 5-pin plug and turn power on.
- Check for appropriate voltages on 16-pin connector with screw terminals jumpered. (See Table 7 for values and see examples below.)

If signals check correctly and motor does not run, inspect wiring harness for loose pins or damaged plastic that could cause poor connections. If connections are good, either control module or motor is defective. If proper signals are not present, check circuit board using procedure below:

12-PIN PLUG (PL-1) ON EASY SELECT BOARD

- Unplug harness from board.
- Check for appropriate voltages on pins with Easy Select Board screw terminals jumpered. (See Table 7 for values and see example below.)

If proper signals are not present, replace Easy Select Board. If present at board and not at 16-pin connector, wiring harness is defective.

TROUBLESHOOTING EXAMPLE:

Motor is not running on a call for heat-pump heating. System is a single-speed heat pump.

- After performing checks in Thermostat section, follow steps 1 thru 5 in Wiring Harness section. Then proceed with example.
- With all thermostat wires removed from Easy Select Board, place a jumper wire between R and Y/Y₂ low-voltage screw terminals on the Easy Select board.
- Check Table 7 for pin number on 16-pin connector associated with the Y/Y₂ signal. The correct pin is #14. The far right column shows that (-) 12vdc should be present between pin #14 and pin #1 (common) on the 16-pin connector.

Table 7—Wiring Connections of FV Fan Coil Wiring Harness

| 16-IN PLUG ON WIRING HARNESS TO MOTOR | | | WIRING HARNESS CONNECTION TO EASY SELECT BOARD | | |
|---------------------------------------|----------------------------|--|--|------------|--|
| Pin on 16-Pin Plug | Description | | Pin on 12-Pin Plug or Set-up Selection | Wire Color | Signal on Pin with Screw Terminal Jumpered to R* |
| 1 | Common | | Pin 9 on PL-1 | Brown | |
| 2 | W1 | Auxiliary Heat Stage 1 | Pin 7 on PL-1 | Violet | 24VAC** |
| 3 | Common | | Pin 10 on PL-1 | Orange | |
| 4 | On/Off Delay Selection | | On/Off Delay Selection | White | |
| 5 | AC/HP Size Selection | | AC/HP Size Selection | Blue | |
| 6 | Y1 | Low Speed AC or HP | Pin 3 on PL-1 | Black | (-) 12VDC** |
| 7 | AC/HP CFM Adjust Selection | | AC/HP CFM Adjust Selection | Black | |
| 8 | Not Used | | N/A | Not Used | |
| 9 | System Type Selection | | System Type Selection | Orange | |
| 10 | Dehumidify | | Pin 12 on PL-1 | Gray | 0V (24VAC on no call) |
| 11 | Aux Heat Size Selection | | Aux Heat Size Selection | Violet | |
| 12 | 24v AC | | Pin 8 on PL-1 | Red | 24VAC continuous |
| 13 | W2 | Auxiliary Heat Stage 2 | Pin 4 on PL-1 | White | 24VAC** |
| 14 | Y/Y2 | Single Speed AC or HP, High Speed 2-Speed AC or HP | Pin 2 on PL-1 | Yellow | (-) 12VDC** |
| 15 | G | Fan | Pin 1 on PL-1 | Green | 24VAC** |
| 16 | Not Used | | N/A | Not Used | |

* Check voltages with 16-Pin Plug disconnected from motor.

** These signals will start motor.

- Set meter to read DC voltage. Place meter between pins #1 and #14 and check for (-) 12vdc (common side of meter on pin #1). If signal is present, the problem is in the module or motor. If signal is not, problem is either in wiring harness or Easy Select Board.

These steps can be repeated for other modes of operation.

To check Easy Select Board:

- Leave jumper wire in place between R and Y/Y2.
- Check Table 7 under "Wiring Harness Connection to Easy Select Board" column and row for pin #14 to see pin# on Easy Select Board that should have voltage. The correct pin is #2. The column on far right will show voltage that should be present between pin #2 and #9 (or #10 common).
- Place meter between pins #2 and #9 on Easy Select Board and check for (-) 12vdc.
- If voltage is present, the wiring harness is bad; if not, the Easy Select Board is bad.

D. Verify Motor Winding Section:

Before proceeding with module replacement, check the following to ensure motor winding section is functional. With control module removed and unplugged from winding section:

- The resistance between any 2 motor leads should be similar.
- The resistance between any motor lead and the unpainted motor end plate should be greater than 100K ohms.

If motor winding section fails one of these tests, it is defective and must be replaced.

START-UP PROCEDURES

Refer to outdoor unit Installation Instructions for system start-up instructions and refrigerant charging method details.

CARE AND MAINTENANCE

For continuing high performance, and to minimize possible equipment failure, it is essential that periodic maintenance be performed on this equipment. The only required maintenance that may be performed by the consumer is filter maintenance.

⚠ WARNING: Disconnect all power to unit before servicing field wires or removing control package. The disconnect (when used) on access panel does not disconnect power to the line side of disconnect, but does allow safe service to all other parts of unit. If unit does not have a disconnect, disregard the foregoing. Instead, make sure that a disconnecting means is within sight from, and is readily accessible from, the unit. Disconnect all electrical power to unit before performing any maintenance or service on it. A failure to follow this warning can cause electrical shock, fire, personal injury, or death.

The minimum maintenance requirements for this equipment are as follows:

- Inspect and clean or replace air filter each month or as required.
- Inspect cooling coil, drain pan, and condensate drain each cooling season for cleanliness. Clean as necessary. An inspection port is provided on all A-coil delta plates. Remove plastic plug to inspect.

QUICK REFERENCE GUIDE

SET-UP INSTRUCTIONS FOR WARMER HEATING TEMPERATURES AND SUPER HUMIDITY CONTROL IN COOLING

LOW VOLTAGE TERMINAL BLOCK

EASY SELECT™

AUX HEAT KW/CFM

AC/HP SIZE

SYSTEM TYPE

AC/HP CFM ADJUST

ON/OFF DELAY

CONTINUOUS FAN

HEATER/MOTOR

MOLEX 12-PIN CONNECTOR

EASY SELECT BOARD

1. Configuration Taps
(See Installation Instructions, for detailed description.)
 - A. AUX HEAT - Set for heater size (Ex: 0-10 for 10 kw)
 - B. AC/HP SIZE - Set for size of outdoor unit
 - C. SYSTEM TYPE - Select "HP COMFORT"
 - D. AC/HP CFM ADJUST - Select "LO"
 - E. ON/OFF DELAY - Select "ENH"
 - F. CONTINUOUS FAN - Select desired speed
2. Install heater with Intelligent Heat Staging, and remove Jumper J2, except when using 5-, 8-, or 10-kw heater.
3. Remove Jumper J1 to activate all dehumidify modes.
4. Complete wiring and install outdoor temperature sensor according to Installation Instructions.

THERMIDISTAT™ CONTROL SETTINGS

1. Set "DIP Switches" - Set the dip switches (back of Thermidistat Control Board) appropriately for specific system being installed.
2. Thermidistat Control Configurations
(See Thermidistat™ Control Installation Instructions for detailed description.)
 - Option 5 (Variable Speed Motors) - set to ON
 - Option 7 (Super Dehumidify) - set to ON
 - Option 9 (Intelligent Heat) - set to ON if installing with a single speed heat pump
 - Option 12 (Heaters during Defrost) - setting "2" is suggested for all heaters
 - Option 16 - Set to ON for warmer heat below 40° F.
 - Option 17 - Select programmable or non-programmable mode.
3. Set desired humidity level on front of Thermidistat (50 to 55% RH recommended). For cool to dehumidify operation, both "dhu" and "cool" must be displayed.

A03100

→ **Fig. 22—Set-Up Instructions for Warmer Heating Temperatures and Super Humidity Control in Cooling**

3. Inspect blower motor and wheel for cleanliness each heating and cooling season. Clean as necessary.
4. Inspect electrical connections for tightness and controls for proper operation each heating and cooling season. Service as necessary. Consult Fan Coil Service Manual available from equipment distributor for maintenance procedures.

⚠ WARNING: As with any mechanical equipment, personal injury can result from sharp metal edges, etc, therefore, care should be taken when removing parts.

Using the Owner's/User Manual furnished in outdoor unit, the installing technician should explain system operation to the consumer with particular emphasis on indoor fan coil operation sounds and filter maintenance.

**PURON® QUICK REFERENCE GUIDE
FOR INSTALLERS AND TECHNICIANS**

- Puron refrigerant operates at 50-70 percent higher pressures than R-22. Be sure that servicing equipment and replacement components are designed to operate with Puron.
- Puron refrigerant cylinders are rose colored.
- Recovery cylinder service pressure rating must be 400 psig, DOT 4BA400 or DOT BW400.
- Puron systems should be charged with liquid refrigerant.
- Use a commercial type metering device in the manifold hose.
- Manifold sets should be 750 psig high-side and 200 psig low-side with 520 psig low-side retard.
- Use hoses with 750 psig service pressure rating.
- Leak detectors should be designed to detect HFC refrigerant.
- Puron, as other HFC's, is only compatible with POE oils.
- Vacuum pumps will not remove moisture from oil.
- Do not use liquid-line filter driers with rated working pressures less than 600 psig.
- Do not install a suction-line filter drier in liquid line.
- POE oils absorb moisture rapidly. Do not expose oil to atmosphere.
- POE oils may cause damage to certain plastics and roofing materials.
- Wrap all filter driers and service valves with wet cloth when brazing.
- A liquid-line filter drier is required on every unit.
- Do not use an R-22 TXV.
- If indoor unit is equipped with an R-22 TXV, it must be changed to a Puron TXV.
- Never open system to atmosphere while it is under a vacuum.
- When system must be opened for service, break vacuum with dry nitrogen and replace filter driers.
- Do not vent Puron into the atmosphere.
- Do not use capillary tube indoor coils.
- Observe all **warnings**, **cautions** and **bold** text.

