

Installation Instructions

NOTE: Read the entire instruction manual before starting the installation.

TABLE OF CONTENTS

	PAGE
SAFETY CONSIDERATIONS	1
INTRODUCTION	1
HEATER PACKAGES	2
INSTALLATION	2
Step 1 — Check Equipment	2
Step 2 — Mount Unit	2
Step 3 — Air Ducts	4
Step 4 — Electrical Connections	4
Step 5 — Refrigerant Tubing Connection and Evacuation ..	6
Step 6 — Refrigerant Flow-Control Device	7
Step 7 — Condensate Drains	7
Step 8 — Accessories	7
Step 9 — Sequence of Operation	8
START-UP PROCEDURES	9
CARE AND MAINTENANCE	9
AIRFLOW PERFORMANCE TABLES	9

SAFETY CONSIDERATIONS

Improper installation, adjustment, alteration, service, maintenance, or use can cause explosion, fire, electrical shock, or other conditions which may cause death, personal injury or property damage. Consult a qualified installer, service agency, or your distributor or branch for information or assistance. The qualified installer or agency must use factory-authorized kits or accessories when modifying this product. Refer to the individual instructions packaged with kits or accessories when installing.

Follow all safety codes. Wear safety glasses, protective clothing and work gloves. Have a fire extinguisher available. Read these instructions thoroughly and follow all warnings or cautions included in literature and attached to the unit. Consult local building codes and the current editions of the National Electrical Code (NEC) NFPA 70.

In Canada, refer to the current editions of the Canadian Electrical Code CSA C22.1.

Recognize safety information. This is the safety-alert symbol . When you see this symbol on the unit and in instruction manuals, be alert to the potential for personal injury.

Understand the signal words **DANGER**, **WARNING**, and **CAUTION**. These words are used with the safety-alert symbol. **DANGER** identifies the most serious hazards which **will** result in severe personal injury or death. **WARNING** signifies hazards

which **could** result in personal injury or death. **CAUTION** is used to identify unsafe practices which **may** result in minor personal injury or product and property damage. **NOTE** is used to highlight suggestions which will result in enhanced installation, reliability, or operation.

WARNING

ELECTRICAL OPERATION HAZARD

Failure to follow this warning could result in personal injury or death.

Before installing or servicing unit, always turn off all power to unit. There may be more than one disconnect switch. Turn off accessory heater power if applicable. Lock out and tag switch with a suitable warning label.

CAUTION

CUT HAZARD

Failure to follow this caution may result in personal injury.

Sheet metal parts may have sharp edges or burrs. Use care and wear appropriate protective clothing and gloves when handling parts.

INTRODUCTION

FZ4A models are R-410A Fan Coils designed for installation flexibility. These units are designed to meet cabinet air leakage of less than 2% at 0.5 inches W.C. and cabinet air leakage less than 1.4% at 0.5 inches W.C. when tested in accordance with ASHRAE 193 standard.

A TXV is used on FZ4ANP(024-061). All FZ4A fan coils use a multi-tap ECM motor for efficiency. These units have been designed for upflow, downflow (kit required), and horizontal orientations, including manufactured and mobile home applications.

These units require a field supplied air filter, and are designed specifically for R-410A refrigerant air conditioners and heat pumps as shipped. These units are available for systems of 24,000 through 60,000 BTUh nominal cooling capacity. Factory-authorized, field - installed electric heater packages are available in sizes 5 through 30kW. See Product Data literature for all available accessory kits.

HEATER PACKAGES

This unit may or may not be equipped with an electric heater package. For units not equipped with factory-installed heat, a factory-approved, field-installed, UL listed heater package is available from your equipment supplier. See unit rating plate for a list of factory-approved heaters. Heaters that are not factory approved could cause damage which would not be covered under the equipment warranty. If fan coil contains a factory-installed heater package, minimum circuit ampacity (MCA) and maximum fuse/breaker may be different than units with a same size field-installed accessory heater. The differences is not an error and is due to calculation difference per UL guidelines.

INSTALLATION

Step 1 — Check Equipment

Unpack unit and move to final location. Remove carton taking care not to damage unit. Inspect equipment for damage prior to installation. File claim with shipping company if shipment is damaged or incomplete.

Locate unit rating plate which contains proper installation information. Check rating plate to be sure unit matches job specifications.

Refer to Table 1. Install the fan coil with the accompanying kit to ensure compliance with low leak requirements of less than 2% cabinet leakage rate at 0.5 inches W.C. and 1.4% cabinet leakage rate at 0.5 inches W.C. when tested in accordance with ASHRAE 193 standard.

NOTE: Units that require a kit to meet low leak requirements have a gasket kit automatically included with shipment.

Table 1 – Gasket Kit Requirement

Unit Size	Kit Needed?
024	Yes
036	Yes
048	No
060	No
061	No

Step 2 — Mount Unit

Unit can stand or lie on floor, or hang from ceiling or wall. Allow space for wiring, piping, and servicing unit.

IMPORTANT: When unit is installed over a finished ceiling and/or living area, building codes may require a field-supplied secondary condensate pan to be installed under the entire unit. Some localities may allow as an alternative, the running of a separate, secondary condensate line. Consult local codes for additional restrictions or precautions.

NOTE: Nuisance sweating may occur if the unit is installed in a humid location with low airflow.

A. Upflow Installation

If return air is to be ducted through a floor, set unit on floor over opening and use 1/8 to 1/4-in (3 to 6 mm) thick fireproof resilient gasket between duct, unit, and floor.

Side return is a field option on slope coil models. Cut opening per dimensions. (See Fig. 1.) A field-supplied bottom closure is required.

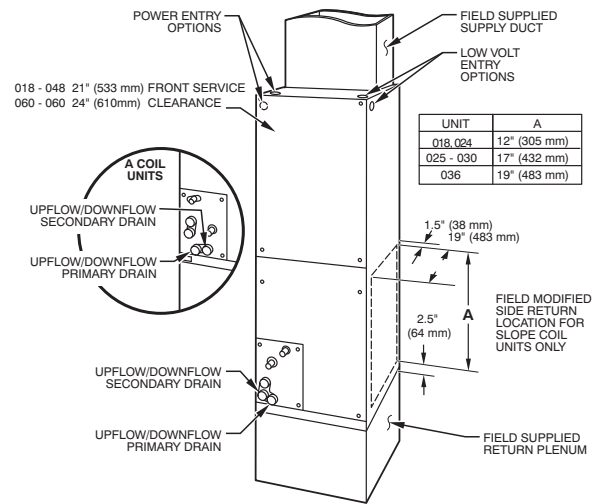

Fig. 1 - Slope Coil Unit in Upflow Application

B. Downflow Installation

In this application, field conversion of the evaporator is required using accessory downflow kit along with an accessory base kit. Use fireproof resilient gasket, 1/8 to 1/4-in (3 to 6 mm) thick, between duct, unit, and floor.

CAUTION

UNIT OR PROPERTY DAMAGE HAZARD

Failure to follow this caution may result in product or property damage.

The conversion of the fan coil to downflow requires special procedures for the condensate drains on both A-coil and slope units. The vertical drains have an overflow hole between the primary and secondary drain holes. This hole is plugged for all applications except downflow, but must be used for downflow. During the conversion process, remove the plastic cap covering the vertical drains only and discard. Remove the plug from the overflow hole and discard. At completion of the downflow installation, caulk around the vertical pan fitting to door joint to retain the low air leak performance of the unit.

NOTE: To convert units for downflow applications, refer to Installation Instructions supplied with kit for proper installation. For slope fan coils, use kit Part No. KFADC0201SLP. For A-coils, use kit Part No. KFADC0401ACL. Use fireproof resilient gasket, 1/8 to 1/4-in (3 to 6 mm) thick, between duct, unit, and floor.

NOTE: Gasket kit number KFAHD0101SLP is also required for all downflow applications to maintain low air leak/low sweat performance.

C. Horizontal Installation

Units must not be installed with access panels facing up or down. All other units are factory built for horizontal left installation. (See Fig. 2 and 3.) When suspending unit from ceiling, dimples in casing indicate suitable location of screws for mounting metal support straps. (See Fig. 2.)

⚠ CAUTION

PROPERTY DAMAGE HAZARD

Failure to follow this caution may result in product or property damage.

For optimum condensate drainage performance in horizontal installations, unit should be leveled along its length and width.

For horizontal applications having high return static and humid return air, the Water Management Kit, KFAHC0125AAA, may need to be used to assist in water management.

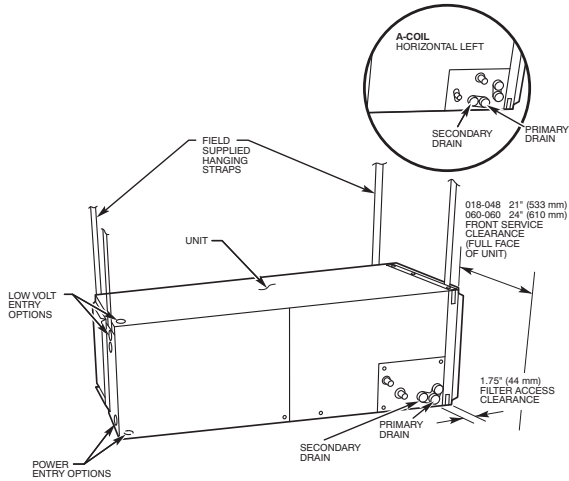

A07566

Fig. 2 - Slope Coil Unit in Horizontal Left Application

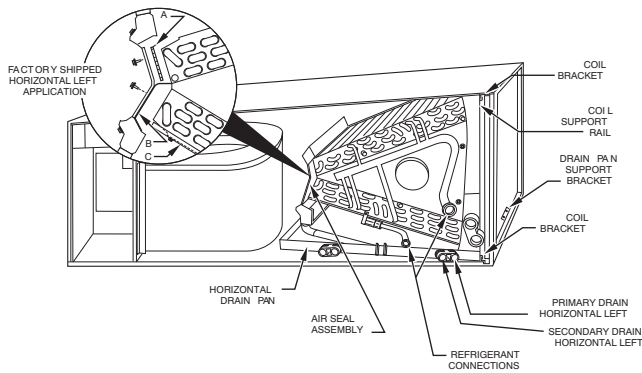

A00072

Fig. 3 - A-Coil in Horizontal Left Application

NOTE: Gasket kit number KFAHD0101SLP is required for horizontal slope coil conversion to maintain low air leak/low sweat performance.

1. Remove blower and coil access panel and fitting panel. (See Fig. 4.)
2. Remove coil mounting screw securing coil assembly to right side casing flange.
3. Remove coil assembly.
4. Lay fan coil unit on its right side and reinstall coil assembly with condensate pan down. (See Fig. 4.)
5. Attach coil to casing flange using coil mounting screw previously removed.
6. Make sure the pan cap in the fitting door is properly seated on the fitting door to retain the low air leak rating of the unit.
7. Add gaskets from kit KFAHD per kit instructions.
8. Align holes with tubing connections and condensate pan connections, and reinstall access panels and fitting panel.

Make sure liquid and suction tube grommets are in place to prevent air leaks and cabinet sweating. Install after brazing.

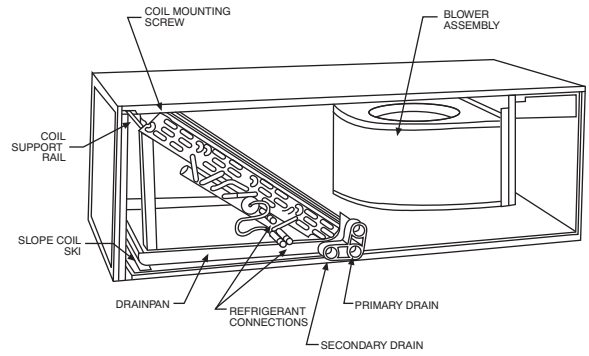

A03001

Fig. 4 - Conversion for Horizontal Right Applications

Horizontal Right Conversion of Units With A-Coils

1. Remove blower and coil access panels. (See Fig. 5.)
2. Remove metal clip securing fitting panel to condensate pan. Remove fitting panel.
3. Remove 2 snap-in clips securing A-coil in unit.
4. Slide coil and pan assembly out of unit.
5. Remove horizontal drain pan support bracket from coil support rail on left side of unit and reinstall on coil support rail on right side of unit. (See Fig. 6.)

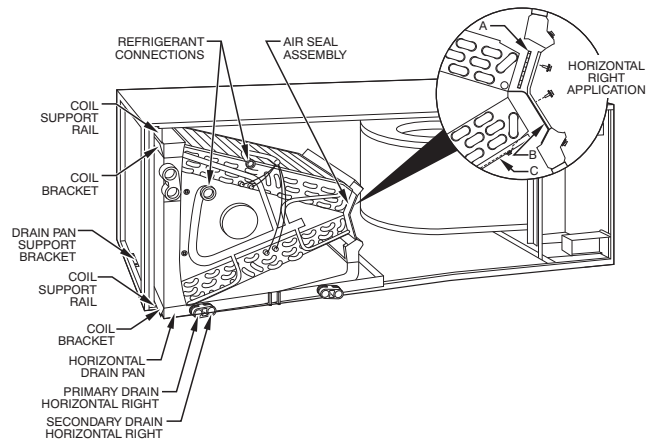

A00071

Fig. 5 - Conversion for Horizontal Right Applications Using A-Coil

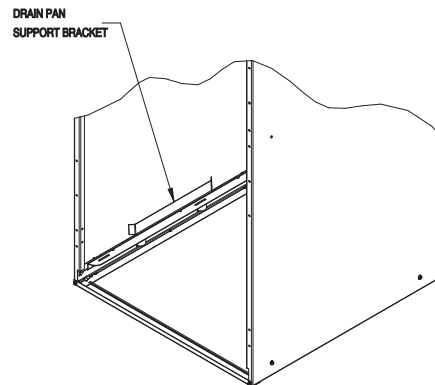

A07571

Fig. 6 - Drain Pan Support Bracket

6. Convert air-seal assembly for horizontal right.
 - a. Remove air-seal assembly from coil by removing 4 screws. (See Fig. 5.)

- b. Remove air splitter (B) from coil seal assembly by removing 3 screws. (See Fig. 3- factory shipped inset.)
 - c. Remove filter plate (A) and install air splitter (B) in place of filter plate.
 - d. Install filter plate (A) as shown in horizontal right application.
 - e. Remove condensate troughs (C) and install on opposite tube sheets.
 - f. Install hose onto plastic spout.
7. Install horizontal pan on right side of coil assembly.
 8. Slide coil assembly into casing. Be sure coil bracket on each corner of vertical pan engages coil support rails.
 9. Reinstall 2 snap-in clips to correctly position and secure coil assembly in unit. Be sure clip with large offsets is used on right side of unit to secure horizontal pan.
 10. Remove two oval fitting caps from the left side of the coil door and fitting panel.
 11. Remove insulation knockouts on right side of coil access panel.
 12. Remove 2 oval coil access panel plugs and reinstall into holes on left side of coil access panel and fitting panel.
 13. Install condensate pan fitting caps (from item 10) in the right side of the coil door making sure that the cap snaps and seats cleanly on the back side of the coil door. Make sure no insulation interferes with seating of the cap.
 14. Reinstall access fitting panels, aligning holes with tubing connections and condensate pan connections. Be sure to re-install metal clip between fitting panel and vertical condensate pan.

Make sure liquid and suction tube grommets are in place to prevent air leaks and cabinet sweating.

D. Manufactured and Mobile Home Housing Applications

1. Fan coil unit must be secured to the structure using field-supplied hardware.
2. Allow a minimum of 24- in (610 mm) clearance from access panels.
3. Recommended method of securing for typical applications:
 - a. If fan coil is away from wall, attach pipe strap to top of fan coil using no. 10 self- tapping screws. Angle strap down and away from back of fan coil, remove all slack, and fasten to wall stud of structure using 5/16- in. lag screws. Typical both sides of fan coil.

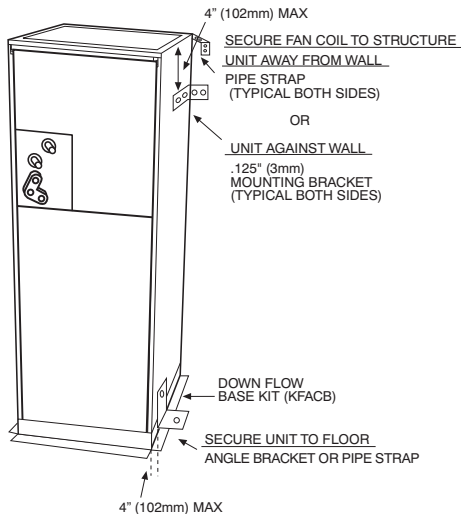

Fig. 7 - A-Coil

A07567

- b. If fan coil is against wall, secure fan coil to wall stud using 1/8- in (3 mm) thick right-angle brackets. Attach brackets to fan coil using no. 10 self- tapping screws and to wall stud using 5/16- in. lag screws. (See Fig. 7.)

Step 3 — Air Ducts

Connect supply-air duct over the outside of 3/4- in (19 mm) flanges provided on supply-air opening. Secure duct to flange, using proper fasteners for type of duct used, and seal duct-to-unit joint. If return-air flanges are required, install factory-authorized accessory kit.

Use flexible connectors between ductwork and unit to prevent transmission of vibration. When electric heater is installed, use heat-resistant material for flexible connector between ductwork and unit at discharge connection. Ductwork passing through unconditioned space must be insulated and covered with vapor barrier.

Units equipped with 20-30kW electric heaters require a 1- in (25 mm) clearance to combustible materials for the first 36- in (914 mm) of supply duct.

Ductwork Acoustical Treatment

Metal duct systems that do not have a 90° elbow and 10- ft (3m) of main duct to first branch takeoff may require internal acoustical insulation lining. As an alternative, fibrous ductwork may be used if constructed and installed in accordance with the latest edition of SMACNA construction standard on fibrous glass ducts. Both acoustical lining and fibrous ductwork shall comply with National Fire Protection Association as tested by UL Standard 181 for Class 1 air ducts.

Step 4 — Electrical Connections

FZ4A units from the factory protect the low voltage circuit with a 3 amp automotive type fuse in-line on the wire harness and Does Not contain a circuit board. Motor speeds and time delay function are built into the motor (see section E for clarification).

When a factory-approved accessory control package has been installed, check all factory wiring per unit wiring diagram and inspect factory wiring connections to be sure none were loosened in transit or installation. If a different control package is required, see unit rating plate.

▲ CAUTION

PROPERTY DAMAGE HAZARD

Failure to follow this caution may result in product or property damage.

If a disconnect switch is to be mounted on unit, select a location where drill or fastener will not contact electrical or refrigerant components.

Before proceeding with electrical connections, make certain that supply voltage, frequency, phase, and ampacity are as specified on the unit rating plate. See unit wiring label for proper field high- and low-voltage wiring. Make all electrical connections in accordance with the NEC and any local codes or ordinances that may apply. Use copper wire only.

The unit must have a separate branch electric circuit with a field-supplied disconnect switch located within sight from, and readily accessible from, the unit.

On units with a factory-installed disconnect with pull-out removed, service and maintenance can be safely performed on only the load side of the control package.

⚠ WARNING

ELECTRICAL SHOCK HAZARD

Failure to follow this warning could result in personal injury or death.

Field wires on the line side of the disconnect found in the fan coil unit remain live, even when the pull-out is removed. Service and maintenance to incoming wiring cannot be performed until the main disconnect switch (remote to the unit) is turned off.

A. Line Voltage Connections

If unit will contain accessory electric heater, remove and discard power plug from fan coil and connect male plug from heater to female plug from unit wiring harness. (See Electric Heater Installation Instructions.)

For units without electric heater:

1. Connect 208/230v power leads from field disconnect to yellow and black stripped leads.
2. Connect ground wire to unit ground lug.

NOTE: Units installed without electric heat should have a field-supplied sheet metal block-off plate covering the heater opening. This will reduce air leakage and formation of exterior condensation.

B. 24-v Control System

Connection To Unit

Wire low voltage in accordance with wiring label on the blower. (See Fig. 8 through 12.) Use no. 18 AWG color-coded, insulated (35°C minimum) wire to make the low-voltage connections between the thermostat, the unit, and the outdoor equipment. If the thermostat is located more than 100-ft (30 m) from the unit (as measured along the low-voltage wire), use no. 16 AWG color-coded, insulated (35°C minimum) wire. All wiring must be NEC Class 1 and must be separated from incoming power leads.

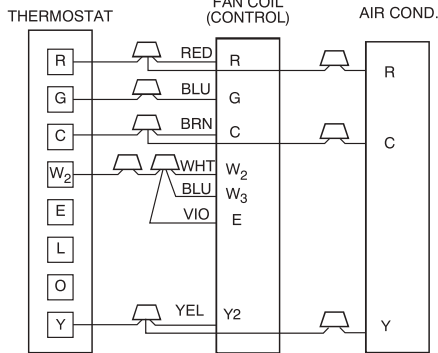

A160008

Fig. 8 - Wiring Layout Single-Stage Air Conditioning Unit

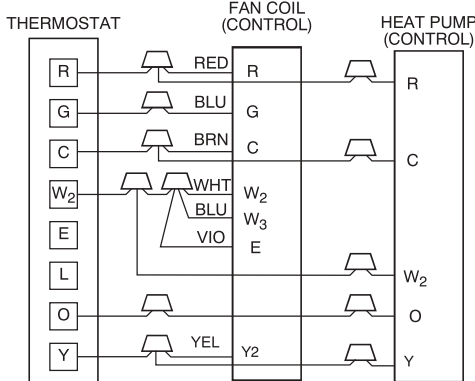
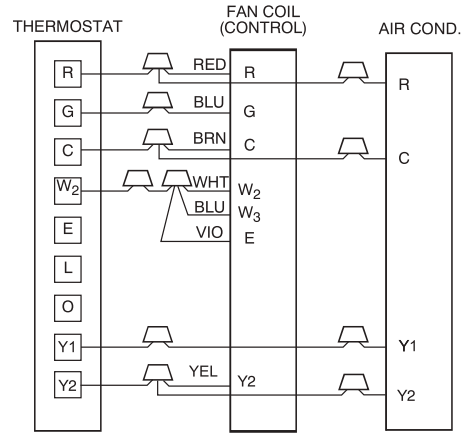

Fig. 9 - Wiring Layout Single-Stage Heat Pump Unit

A160009



A160010

Fig. 10 - Wiring Layout Two-Stage Air Conditioning Unit

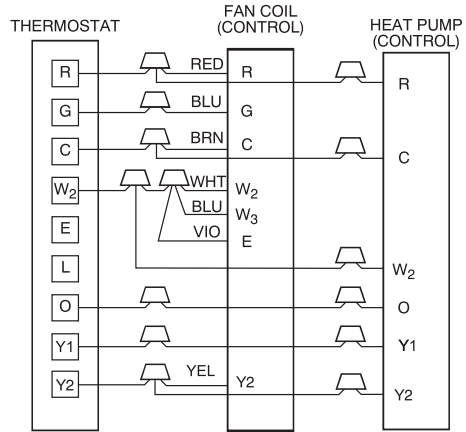

A16011

Fig. 11 - Wiring Layout Two-Stage Heat Pump

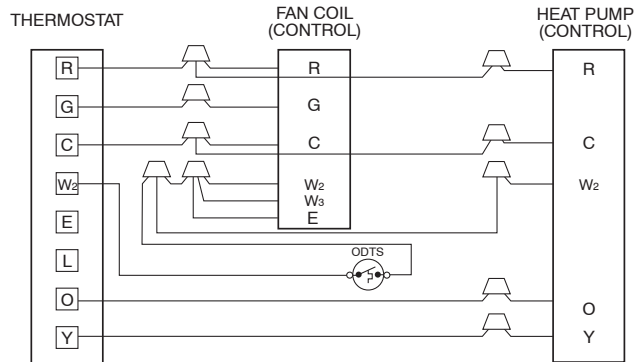

A03088

Fig. 12 - Wiring Layout Heat Pump Unit (Cooling and 2-Stage Heat for Manufactured Housing)

Refer to outdoor unit wiring instructions for any additional wiring procedure recommendations.

Transformer Information

Transformer is factory-wired for 230v operation. For 208v applications, disconnect the black wire from the 230v terminal on transformer and connect it to the 208v terminal. (See Fig. 13.)

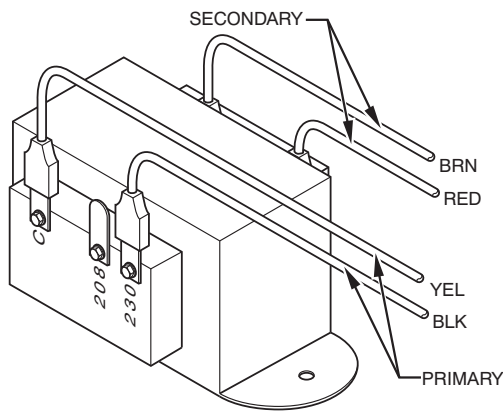

A05182

Fig. 13 - Transformer Connections

Heater Staging

If electric heat staging is required, a multi-stage heating room thermostat is required. Consult your equipment supplier for a suitable thermostat.

C. Manufactured Housing

In manufactured housing applications, the Code of Federal Regulations, Title 24, Chapter XX, Part 3280.714 requires that supplemental electric heat be locked out at outdoor temperatures above 40°F (4°C), except for a heat pump defrost cycle. Refer to Fig. 12 for typical low voltage wiring with outdoor thermostat.

D. Ground Connections

⚠ WARNING

ELECTRICAL SHOCK HAZARD

Failure to follow this warning could result in personal injury or death.

According to NEC, ANSI/NFPA 70, and local codes, the cabinet must have an uninterrupted or unbroken ground to minimize personal injury if an electrical fault should occur. The ground may consist of electrical wire or metal conduit when installed in accordance with existing electrical codes. If conduit connection uses reducing washers, a separate ground wire must be used.

NOTE: Use UL-listed conduit and conduit connector for connecting supply wire(s) to unit to obtain proper grounding. Grounding may also be accomplished by using grounding lugs provided in control box.

E. Minimum CFM and Motor Speed Selection

The fan speed selection is done at the motor connector. Units with or without electric heaters require a minimum CFM. Refer to the unit wiring label to ensure that the fan speed selected is not lower than the minimum fan speed indicated.

Tap 1	Low	90 sec off delay
Tap 2	Medium	90 sec off delay
Tap 3	High	90 sec off delay
Tap 4	Electric heat †	0 sec off delay
Tap 5	Max ‡	0 sec off delay

† electric heat airflow is same CFM as Tap 3, except 0 sec off delay
‡ high static applications, see airflow tables for max airflow

To change motor speeds disconnect the BLUE fan lead from motor connector terminal #2 (factory default position) and move to desired speed-tap; 1, 2, 3, or 5.

On single stage systems with dehum and two stage systems, use blower speed taps 2 and 3 for straight match systems and blower speed taps 1 and 2 for up-sized indoor systems..

Speed-taps 1, 2, and 3 have a 90 second blower off time delay pre-programmed into the motor. Speed-tap 4 is used for electric heat only (with 0 second blower time delay) and the WHITE wire should remain on tap 4. Speed-tap 5 is used for high static applications, but has a 0 second blower time delay pre-programmed into the motor. See Airflow Performance tables for actual CFM. Also, see Fig. 14 for motor speed selection location.

NOTE: In low static applications, lower motor speed tap should be used to reduce possibility of water being blown off coil.

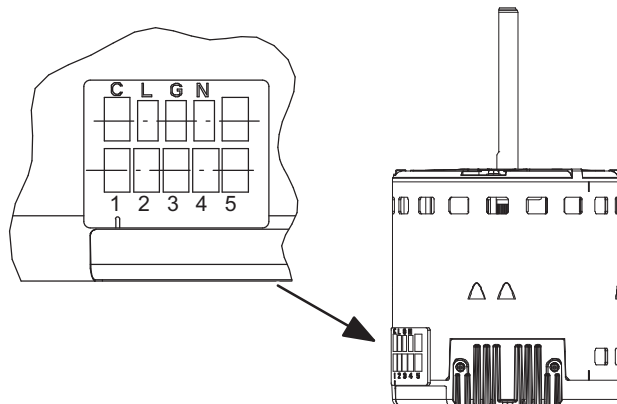

Speed Taps may be located on motor, or on plug close to motor.

A160016

Fig. 14 - Motor Speed Connection

Step 5 — Refrigerant Tubing Connection and Evacuation

Use accessory tubing package or field-supplied tubing of refrigerant grade. Suction tube must be insulated. Do not use damaged, dirty, or contaminated tubing because it may plug refrigerant flow-control device. ALWAYS evacuate the coil and field-supplied tubing to 500 microns before opening outdoor unit service valves.

⚠ CAUTION

PRODUCT DAMAGE HAZARD

Failure to follow this caution may result in product or property damage.

A brazing shield **MUST** be used when tubing sets are being brazed to the unit connections to prevent damage to the unit surface and condensate pan fitting caps.

Units have sweat suction and liquid tube connections. Make suction tube connection first.

1. Cut tubing to correct length.
2. Insert tube into sweat connection on unit until it bottoms.
3. Braze connection using silver bearing or non-silver bearing brazing materials. Do not use solder (materials which melt below 800°F / 427°C). Consult local code requirements.
4. Evacuate coil and tubing system to 500 microns using deep vacuum method.

⚠ CAUTION

PRODUCT DAMAGE HAZARD

Failure to follow this caution may result in product or property damage.

Wrap a wet cloth around rear of fitting to prevent damage to piston assembly or TXV and factory-made joints.

Step 6 — Refrigerant Flow- Control Device

The FZ4ANP(024-061) size units come equipped with a R-410A refrigerant TXV.

Always use outdoor units designed to match indoor fan coil applications.

⚠ CAUTION

PRODUCT OPERATION HAZARD

Failure to follow this caution may result in improper product operation.

If using a TXV in conjunction with a single-phase reciprocating compressor, a compressor start capacitor and relay are required. Consult outdoor unit pre-sale literature for start assist kit part number.

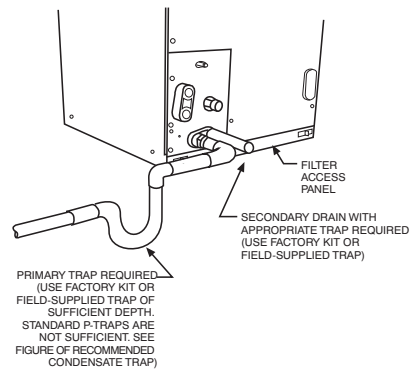

A03003

Fig. 16 - Condensate Trap and Unit

Step 7 — Condensate Drains

To connect drains, the cap openings must be removed. Use a knife to start the opening near the tab and using pliers, pull the tab to remove the disk. Clean the edge of the opening if necessary and install the condensate line. Finally caulk around the lines where they exit the fitting to retain the low leak rating of the unit.

⚠ CAUTION

UNIT OR PROPERTY DAMAGE HAZARD

Failure to follow this caution may result in product or property damage.

The conversion of the fan coil to downflow requires special procedures for the condensate drains on both A-coil and slope units. The vertical drains have an overflow hole between the primary and secondary drain holes. This hole is plugged for all applications except downflow, but must be used for downflow. During the conversion process, remove the plastic cap covering the vertical drains only and discard. Remove the plug from the overflow hole and discard. At completion of the downflow installation, caulk around the vertical pan fitting to door joint to retain the low air leak performance of the unit.

⚠ CAUTION

PROPERTY DAMAGE HAZARD

Failure to follow this caution may result in product or property damage.

Shallow running traps are inadequate and DO NOT allow proper condensate drainage. (See Fig. 17.)

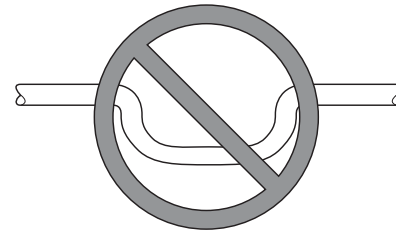

DO NOT USE SHALLOW RUNNING TRAPS!

A03013

Fig. 17 - Insufficient Condensate Trap

NOTE: When connecting condensate drain lines, avoid blocking filter access panel, thus preventing filter removal. After connection, prime both primary and secondary condensate traps.

NOTE: If unit is located in or above a living space where damage may result from condensate overflow, a field-supplied, external condensate pan should be installed underneath the entire unit, and a secondary condensate line (with appropriate trap) should be run from the unit into the pan. Any condensate in this external condensate pan should be drained to a noticeable place. As an alternative to using an external condensate pan, some localities may allow the use of a separate 3/4-in (19 mm) condensate line (with appropriate trap) to a place where the condensate will be noticeable. The owner of the structure must be informed that when condensate flows from the secondary drain or external condensate pan, the unit requires servicing or water damage will occur.

Install traps in the condensate lines as close to the coil as possible. (See Fig. 16.) Make sure that the outlet of each trap is below its connection to the condensate pan to prevent condensate from overflowing the drain pan. Prime all traps, test for leaks, and insulate traps if located above a living area. Condensate drain lines should be pitched downward at a minimum slope of 1-in (25 mm) for every 10-ft (3 m) of length. Consult local codes for additional restrictions or precautions.

Step 8 — Accessories

Humidifier

Connect humidifier and humidistat to fan coil unit as shown in Fig. 18 and Fig. 19. The cooling lockout relay is optional.

Units are equipped with primary and secondary 3/4-in. FPT drain connections. For proper condensate line installations see Fig. 1, 2, 3, 4 and 5. To prevent property damage and achieve optimum drainage performance, BOTH primary and secondary drain lines should be installed and include properly-sized condensate traps. (See Fig. 15 and 16.) Factory-approved condensate traps are available. It is recommended that PVC fittings be used on the plastic condensate pan. Finger-tighten plus 1-1/2 turns. Do not over-tighten. Use pipe dope.

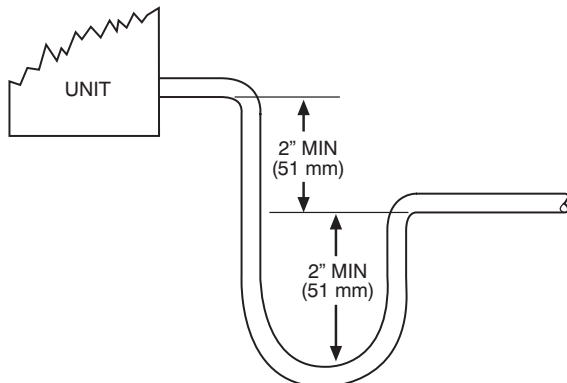

A03002

Fig. 15 - Recommended Condensate Trap

Step 9 — Sequence of Operation

A. Continuous Fan

Thermostat closes R to G. G energizes fan relay on PCB which completes circuit to indoor blower motor. When G is de-energized, there is a 90-sec delay before relay opens.

B. Cooling Mode

Thermostat energizes R to G, R to Y, and R to O (heat pump only). G energizes fan relay on PCB which completes circuit to indoor blower motor. When G is de-energized, there is a 90-sec delay before fan relay opens.

C. Heat Pump Heating with Auxiliary Electric Heat

Thermostat energizes R to G, R to Y, and R to W. G energizes fan relay on PCB which completes circuit to indoor blower motor. W energizes electric heat relay(s) which completes circuit to heater element(s). When W is de-energized, electric heat relay(s) open, turning off heater elements. When G is de-energized there is a 90-sec delay before fan relay opens.

D. Electric Heat or Emergency Heat Mode

Thermostat closes R to W. W energizes electric heat relay(s) which completes circuit to heater element(s). Blower motor is energized through normally closed contacts on fan relay. When W is de-energized, electric heat relay(s) opens.

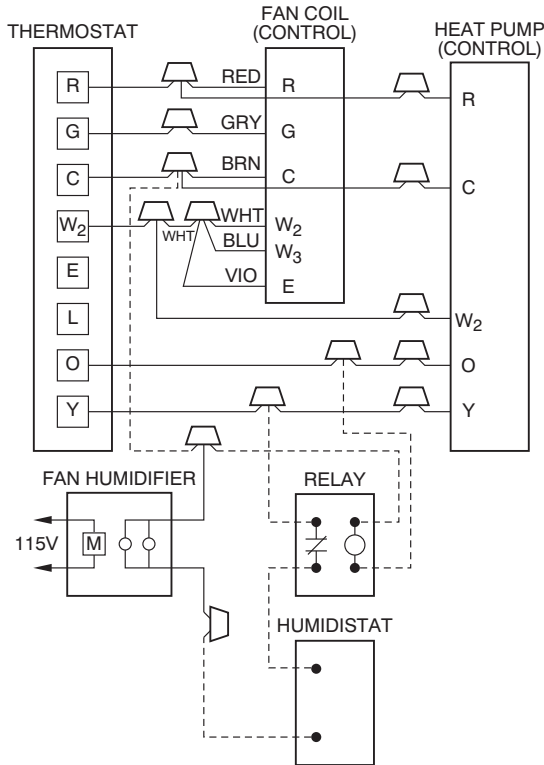

Fig. 18 - Wiring Layout of Humidifier to Heat Pump

A95294

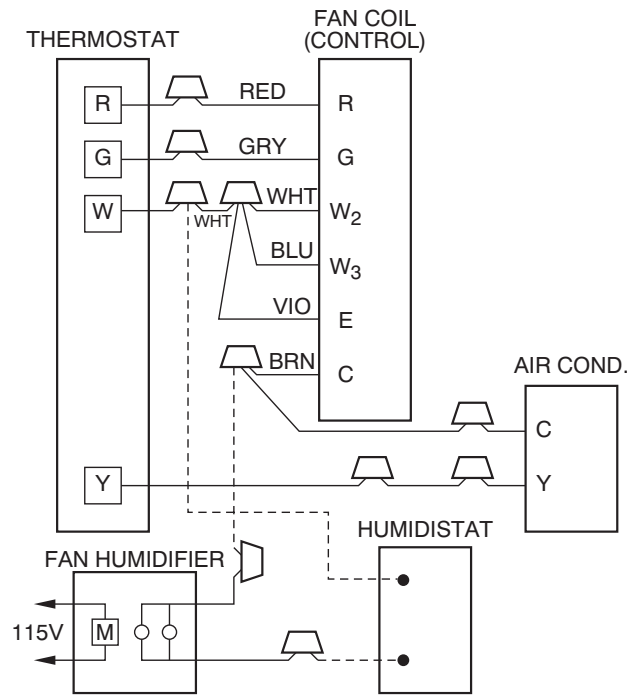

Fig. 19 - Wiring Layout of Humidifier to Fan Coil With Electric Heat

A95295

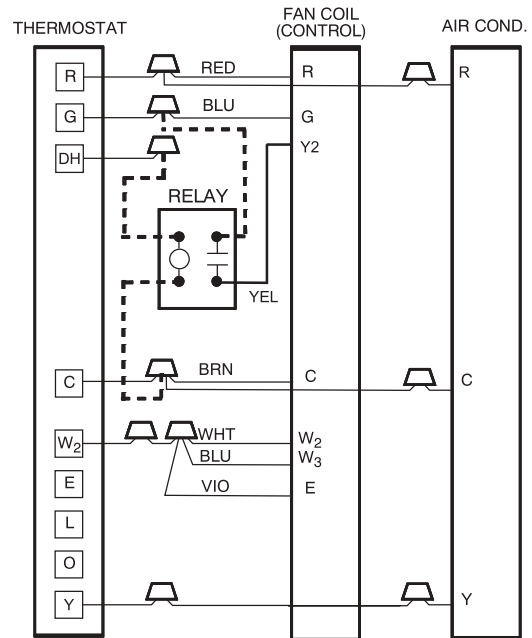
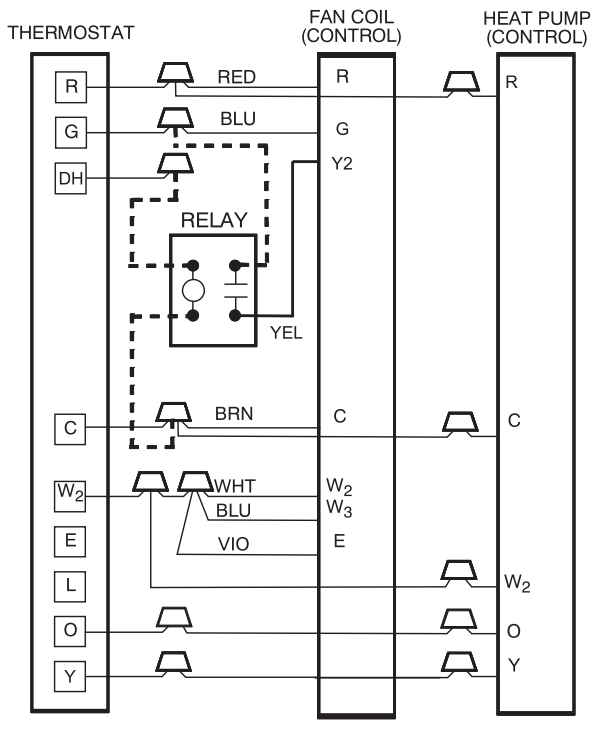

Fig. 20 - Wiring Layout DEHUM Option for Single-Stage Air Conditioning Unit

A160012

NOTE: DEHUM can only be used if a lower tap is available on the motor.



A160013

Fig. 21 - Wiring Layout DEHUM Option for Heat Pump Unit

START-UP PROCEDURES

Refer to outdoor unit Installation Instructions for system start-up instructions and refrigerant charging method details.

CAUTION

UNIT COMPONENT HAZARD

Failure to follow this caution may result in product damage.

Never operate unit without a filter. Damage to blower motor or coil may result. Factory authorized filter kits must be used when locating the filter inside the unit. For those applications where access to an internal filter is impractical, a field-supplied filter must be installed in the return duct system.

CARE AND MAINTENANCE

To continue high performance and minimize possible equipment failure, it is essential that periodic maintenance be performed on this equipment. Consult your local dealer as to the proper frequency of maintenance contract.

The ability to properly perform maintenance on this equipment requires certain mechanical skills and tools. If you do not possess these, contact your dealer for maintenance. The only consumer service recommended or required is filter replacement or cleaning on a monthly basis.

Table 2 – FZ4A Airflow Performance (CFM)

MODEL & SIZE	BLOWER SPEED	0.10	0.20	0.30	0.40	0.50	0.60
FZ4A 024	Tap 5	969	936	892	835	763	676
	Tap 4	826	795	766	743	706	660
	Tap 3	755	736	711	679	639	593
	Tap 2	573	541	507	471	434	394
	Tap 1	573	541	507	471	434	394
FZ4A 036	Tap 5	1301	1276	1245	1218	1176	1121
	Tap 4	1227	1191	1169	1143	1105	1074
	Tap 3	1209	1190	1166	1136	1100	1059
	Tap 2	792	753	710	665	616	564
	Tap 1	547	485	429	380	337	302
FZ4A 048	Tap 5	1743	1712	1679	1642	1610	1574
	Tap 4	1669	1634	1599	1564	1531	1499
	Tap 3	1496	1454	1415	1378	1344	1312
	Tap 2	1112	1066	1021	978	937	897
	Tap 1	822	764	702	634	562	485
FZ4A 060	Tap 5	1897	1867	1836	1808	1774	1736
	Tap 4	1817	1785	1757	1724	1693	1655
	Tap 3	1878	1848	1816	1782	1747	1711
	Tap 2	1445	1403	1360	1316	1271	1225
	Tap 1	1086	1026	963	895	822	746
FZ4A 061	Tap 5	2030	1995	1961	1927	1888	1842
	Tap 4	1811	1775	1740	1703	1664	1613
	Tap 3	1671	1666	1654	1634	1607	1573
	Tap 2	1350	1332	1309	1280	1245	1206
	Tap 1	1188	1063	949	846	753	670

NOTES:

- Airflow based upon dry coil at 230v with factory-approved filter and electric heater (2 element heater sizes 024 through 036, 3 element heater sizes 048 through 061). For FZ4A models, airflow at 208 volts is approximately the same as 230 volts because the multi-tap ECM motor is a constant torque motor. The torque doesn't drop off at the speeds the motor operates.
- To avoid potential for condensate blowing out of drain pan prior to making drain trap:
Return static pressure must be less than 0.40 in. wc.
Horizontal applications of 048 - 061 sizes must have supply static greater than 0.20 in. wc.
- Airflow above 400 cfm/ton on 048- 061 size could result in condensate blowing off coil or splashing out of drain pan.

Table 3 – FZ4A Air Delivery Performance Correction Component Pressure Drop (in. wc) at Indicated Airflow (Dry to Wet Coil)

UNIT SIZE	CFM															
	500	600	700	800	900	1000	1100	1200	1300	1400	1500	1600	1700	1800	1900	2000
024	0.034	0.049	0.063	0.076	0.089	--	--	--	--	--	--	--	--	--	--	--
036	--	--	--	--	--	0.070	0.080	0.090	0.099	--	--	--	--	--	--	--
048	--	--	--	--	--	--	--	--	--	0.063	0.070	0.076	0.083	0.090	--	--
060	--	--	--	--	--	--	--	--	--	--	--	0.049	0.054	0.059	0.065	0.070
061	--	--	--	--	--	--	--	--	--	--	--	0.027	0.031	0.035	0.039	0.043

Table 4 – Electric Heater Static Pressure Drop (in. wc)

FZ4A024 - 036			FZ4A048 - 060		
HEATER ELEMENTS	kW	EXTERNAL STATIC PRESSURE CORRECTION	HEATER ELEMENTS	kW	EXTERNAL STATIC PRESSURE CORRECTION
0	0	+ .02	0	0	+ .04
1	3, 5	+ .01	2	8, 10	+ .02
2	8, 10	0	3	9, 15	0
3	9, 15	- .02	4	20	- .02
4	20	- .04	6	18, 24, 30	- .10

R-410A QUICK REFERENCE GUIDE

- R-410A refrigerant operates at 50-70 percent higher pressures than R-22. Be sure that servicing equipment and replacement components are designed to operate with R-410A refrigerant.
- R-410A refrigerant cylinders are rose colored.
- Recovery cylinder service pressure rating must be 400 psig, DOT 4BA400 or DOT BW400.
- R-410A refrigerant systems should be charged with liquid refrigerant. Use a commercial type metering device in the manifold hose when charging into suction line with compressor operating
- Manifold sets should be 700 psig high side and 180 psig low side with 550 psig low-side retard.
- Use hoses with 700 psig service pressure rating.
- Leak detectors should be designed to detect HFC refrigerant.
- R-410A refrigerant, as with other HFCs, is only compatible with POE oils.
- Vacuum pumps will not remove moisture from oil.
- Do not use liquid-line filter driers with rated working pressures less than 600 psig.
- Do not leave R-410A refrigerant suction line filter driers in line longer than 72 hours.
- Do not install a suction-line filter drier in liquid line.
- POE oils absorb moisture rapidly. Do not expose oil to atmosphere.
- POE oils may cause damage to certain plastics and roofing materials.
- Wrap all filter driers and service valves with wet cloth when brazing.
- A factory approved liquid-line filter drier is required on every unit.
- Do NOT use an R-22 TXV.
- If indoor unit is equipped with a R-22 TXV or piston metering device, it must be changed to a hard-shutoff R-410A refrigerant TXV.
- Never open system to atmosphere while it is under a vacuum.
- When system must be opened for service, recover refrigerant, evacuate then break vacuum with dry nitrogen and replace filter driers. Evacuate to 500 microns prior to recharging.
- Do not vent R-410A refrigerant into the atmosphere.
- Do not use capillary tube coils.
- Observe all **warnings**, **cautions**, and **bold** text.
- All indoor coils must be installed with a hard-shutoff R-410A refrigerant TXV metering device.