

Installation Instructions

RESCO™ Vent Tables For Category I Fan-Assisted Furnaces

NOTE: Read the entire instruction manual before starting the installation.

SAFETY CONSIDERATIONS

Installing and servicing heating equipment can be hazardous due to gas and electrical components. Improper installation, adjustment, alterations, service, maintenance, or use can cause explosion, fire, electrical shock, asphyxiation, or other conditions which may cause personal injury, death, or property damage. Only trained and qualified personnel should install, repair, or service heating equipment.

Wear safety glasses, protective clothing, and work gloves. Have a fire extinguisher available during start-up and adjustment procedures and service calls. Read these instructions thoroughly. Follow all warnings or cautions included in literature and attached to equipment.

Follow all safety codes including local building codes, the National Fuel Gas Code (NFGC) ANSI Z223.1-1992/NFPA 54-1992 in the United States and the National Standard of Canada for Natural Gas and Propane Installation Codes (NSCNGPIC) CAN/CGA-B149.1 and .2-M91 and Amendment No. 1 in Canada.

Recognize safety information. This is the safety-alert symbol . When you see this symbol on the furnace and in instructions or manuals, be alert to the potential for personal injury.

Understand the signal words DANGER, WARNING, and CAUTION. These words are used with the safety-alert symbol. DANGER identifies the most serious hazards which **will** result in severe personal injury or death. WARNING signifies a hazard which **could** result in personal injury or death. CAUTION is used to identify unsafe practices which **would** result in minor personal injury or product and property damage.

INTRODUCTION

Category I furnaces operate with a nonpositive vent static pressure to limit the potential for vent gas leakage, and operate with a flue loss not less than 17 percent to limit the potential for condensation in the venting system.

This information supplements the information found in the Installation, Start-Up, and Operating Instructions provided with this furnace.

All venting instructions for Category I fan-assisted or induced-draft appliances are included in these instructions.

Refer to the **RESCO™** Table Application Chart located on page 5 to determine the appropriate table to use for the furnace type and vent type.

References made in this publication to the NFGC NFPA 54-1992/ANSI Z223.1-1992 apply to installations in the United States of America. References made to the NSCNGPIC CAN/CGA-B149.1-M91 and .2-M91 and Amendment No. 1 apply to installations in Canada. Venting systems for **RESCO™** fan-assisted furnaces shall be made in accordance with 1 of the above codes and all authorities having jurisdiction.

GENERAL INSTRUCTIONS

These instructions are for fan-assisted furnaces classified as Category I furnaces in accordance with ANSI Z21.47b-1992.

Type-B connector and vent pipe, single-wall metal connector pipe, and/or lined masonry chimneys shall be used to vent Category I furnaces in accordance with these venting instructions. Chimneys shall conform to ANSI/NFPA 211-1992 in the United States and to a Provincial or Territorial Building Code in Canada (in its absence, the National Building Code of Canada).

A clay tile chimney liner in poor condition can be relined in lieu of repairing or rebuilding if the rest of the chimney is in good condition. If the rest of the chimney is in poor condition, repairing or rebuilding is required. UL listed (ULC listed in Canada) metal liner or a UL listed Type-B vent pipe shall be used for relining. Rebuilding and repairing shall conform to ANSI/NFPA 211-1992.

A chimney without a clay tile liner, which is otherwise in good condition, shall be rebuilt to conform to ANSI/NFPA 211-1992 or be lined with a UL listed (ULC listed in Canada) metal liner or UL listed Type-B vent. Relining with a listed metal liner or Type-B vent is considered to be a vent-in-a-chase.

If a metal liner or Type-B vent is used to line a chimney, no appliance shall be vented into the annular space between the chimney and the metal liner.

Clay tile-lined chimneys exposed to the outdoors below the roof line may require relining with a listed metal liner to reduce vent gas condensation in cold climates. Experience in local areas with standard draft-hood-equipped furnaces will indicate whether exposed tile-lined chimneys have condensation problems. Fan-assisted furnaces installed in accordance with these instructions will not have chimney condensation problems if standard gas-fired draft-hood-equipped furnaces installed in accordance with the NFGC or NSCNGPIC have not experienced condensation problems in exposed tile-lined chimneys.

APPLIANCE APPLICATION REQUIREMENTS

Appliance operation has a significant impact on the performance of the venting system. If the appliances are sized, installed, adjusted, and operated properly, the venting system and/or the appliances should not suffer from condensation and corrosion.

The venting system and all appliances shall be installed in accordance with applicable listings, standards, and codes.

1. The furnace should be sized to provide 100 percent of the design heating load requirement plus any margin that occurs because of furnace model size capacity increments. Heating load estimates can be made using approved methods available from **RESCO™**, Air Conditioning Contractors of America (Manual J), American Society of Heating, Refrigerating, and Air-Conditioning Engineers, or others. Excessive oversizing of the furnace could cause the furnace and/or vent to fail prematurely.
2. When a metal vent or metal liner is used, the vent must be in good condition and be installed in accordance with the vent manufacturer's instructions.
3. When a masonry chimney is used, chimney construction must conform to ANSI/NFPA 211 1992 and must be in good condition. Inspections before the sale and at the time of installation will determine the acceptability of the chimney or the need for repair and/or (re)lining. An inspection chart is included on page 4. If the inspection of a previously used tile-lined chimney:
 - a. Shows signs of vent gas condensation, the chimney should be relined in accordance with these venting tables with a listed metal liner or Type-B vent to reduce condensation. If a condensate drain is required by local code, refer to the NFGC, Section 7.9 for additional information on condensate drains.
 - b. Indicates the chimney exceeds the maximum permissible size in these tables, the chimney should be rebuilt or relined to conform to these instructions.
4. The return-air temperature must be at least 60°F db except for brief periods of time during warm-up from setback at no lower than 55°F db or during initial start-up from a standby condition.
5. The furnace shall be adjusted according to the Installation, Start-Up, and Operating Instructions provided with the furnace for the following:
 - a. Gas input rate—Insufficient gas input rate can cause low vent gas temperatures causing condensation and corrosion in the furnace and/or venting system. Derating is permitted only for altitudes above 2000 ft.
 - b. Midpoint of the air temperature rise range—Low air temperature rise can cause low vent gas temperature.
 - c. Thermostat heat anticipation or cycle rate to reduce short cycling.
6. Air for combustion must not be contaminated by halogen compounds which include chlorides, fluorides, bromides, and iodides. These compounds are found in many common home products such as detergent, paint, glue, aerosol spray, bleach, cleaning solvent, salt, and air freshener, and can cause corrosion of furnaces and vents. Avoid using such products in the combustion-air supply.
Furnace use during construction of the building could cause the furnace to be exposed to halogen compounds, causing premature corrosion failure of the furnace or venting system.
7. Vent dampers on any appliance connected to the common vent can cause condensation and corrosion in the venting system. Do not use vent dampers on appliances common vented with this furnace. These venting tables apply only to appliances without vent dampers.

VERTICAL VENT OR CHIMNEY SIZING AND INSTALLATION

1. The **RESCO™** Tables found on the following pages are based on the GAMA Venting Tables, the NFGC, and the NSCNPGIC. **RESCO™** Tables are designed to be used with only Category I fan-assisted furnaces. The **RESCO™** Tables provide a simple method to size typical vent and chimney installations without referring to the GAMA Venting Tables, the NFGC, and the NSCNPGIC. Additional venting and chimney configurations are possible by using the GAMA Venting Tables, the NFGC, or the NSCNPGIC.
2. Refer to the Installation Instructions titled VENTING TABLES CATEGORY I CENTRAL FURNACES, A.G.A., GAMA for full information concerning the requirements to use metal vents and masonry chimneys for these furnaces.

The following information and warning must be considered in addition to the requirements defined in the GAMA Venting Tables Section III General Venting Requirements, the NFGC, and the NSCNPGIC.

If a vent (common or dedicated) becomes blocked, the furnace will be shut off by the draft safeguard switch located on the inducer assembly.

⚠ WARNING: Do not bypass the draft safeguard switch, as an unsafe condition could exist which must be corrected. Failure to follow this warning could result in a build-up of carbon monoxide and lead to personal injury or death.

REMOVAL OF EXISTING FURNACES FROM COMMON VENT SYSTEM

1. In replacement installations where an existing vent system may be used, inspect the vent system for condition, size, type of material, and height to meet the appliance application requirements. If it is oversized, condensation could corrode the venting system. Installation of a new venting system may be required.
2. When removing an existing furnace from a venting system serving other appliances, the vent system is likely to be too large to vent the remaining attached appliances properly.

The following steps shall be followed with each appliance remaining connected to the common venting system placed in operation, while the other appliances remaining connected to the common venting system are not in operation.

- a. Seal any unused openings in the common venting system.
- b. Visually inspect the venting system for proper size and horizontal pitch and determine there is no blockage or restriction, leakage, corrosion, and other deficiencies which could cause an unsafe condition.
- c. Insofar as is practical, close all building doors and windows and all doors between space in which appliances remaining connected to the common venting are located and other spaces of the building. Turn on clothes dryers and any appliance not connected to the common venting system. Turn on any exhaust fans such as range hoods and bathroom exhausts, so they will operate at maximum speed. Do not operate a summer exhaust fan. Close fireplace dampers.

- d. Follow the lighting instructions. Place the appliance being inspected in operation. Adjust thermostat so appliance will operate continuously.
- e. Test for spillage at the draft hood relief opening after 5 minutes of main burner operation. Use the flame of a match or candle.
- f. After it has been determined that each appliance remaining connected to the common venting system properly vents when tested as outlined above, return doors, windows, exhaust fans, fireplace dampers, and any other gas-burning appliance to their previous conditions of use.
- g. If improper venting is observed during any of the above tests, the common venting system must be corrected. The vent system or vent connectors may need to be resized according to these instructions to approach the minimum size using the appropriate GAMA Venting Tables, Parts 7 and 11 of the NFGC NFPA 54-1992/ANSI Z223.1- 1992 in the United States or Part 7 of the NSCNPGIC CAN/CGA-B149.1-M91 or .2- M91 and Amendment No. 1 in Canada, and all authorities having jurisdiction.

CHIMNEY INSPECTION CHART

For additional requirements refer to the National Fuel Gas Code NFPA 54-1992/ANSI Z223.1-1992 and ANSI/NFPA 211-1992 Chimneys, Fireplaces, Vents, and Solid Fuel Burning Appliances in the U.S.A. or to the Canadian Installation Codes CAN/CGA-B149.1M91 and .2M91 and Amendment No. 1 in Canada.



RESCO™ TABLE APPLICATION REQUIREMENTS

The use of these tables is restricted as follows:

1. NR = Not Recommended (Vent Pressurization or Condensation May Occur).
2. For connector or vent configurations between table entries, such as vent heights, connector rises, and/or laterals:
 - a. Connector size—Choose the larger of the connector sizes.
 - b. Minimum vent size (Tables 1, 2, 3, 10, and 11)—Choose the larger of the vent sizes.
 - c. Maximum vent size (Tables 10 and 11)—Choose the smaller of the vent sizes.

If 1 of the sizes is NR, the GAMA Venting Tables may give a usable size.

See **EXAMPLE 2: INTERPOLATION BETWEEN TABLE ENTRIES** on page 15.
3. Installations may be up to 10,000 ft altitude. See tables for altitudes at which the common vent connectors or dedicated (Single Appliance) vents may be installed. No altitude limitation is required for a common vent or chimney or for draft-hood-equipped water heater connector. Although appliance input shall be derated 4 percent per 1000 ft above sea level starting at 2000 ft altitude, use the sea level input in **RESCO™** Tables. In Tables 1 through 11 (Except Table 9), the code letters indicate the highest altitudes at which connectors or dedicated vents shall be installed.
4. A vent or chimney may be offset as noted in the second table below and as shown in Fig. 1, 2, 6, 7, or 8.
5. For chimneys exposed to the outdoors, refer to venting General Instruction section.
6. Common-vented appliances only:
 - a. One **RESCO™** Category I fan-assisted furnace with 1 Category I draft-hood-equipped, 50 MBH input or less water heater.
 - b. Size common vent and furnace connectors per **RESCO™** Tables 1 through 8. Size the connector and vent (Chimney) from the same **FURNACE INPUT** column.
 - c. For water heater connectors, refer to **RESCO™** Table 9.
 - d. Vent connectors may be manifolded (common-vented below the vent) as noted in the second table below and as shown in Fig. 5. A manifolded connector shall be sized as a common vent (not a connector) with the same table used to size the connectors and common vent. If the vent or furnace connector is Type-B, the manifolded connector shall also be Type-B. For a chimney sized with Table 7 or 8, single-wall pipe may be used for a manifolded connector, but Type-B is recommended.
 - e. Vent dampers shall not be used on water heaters.
7. For dedicated-vent furnaces, size per **RESCO™** Tables 10 and 11.
8. Use the GAMA venting tables for additional configurations.
9. For additional requirements, refer to the NFGC Parts 7 and 11 in the U.S.A. and the NSCPGIC Part 7 and Amendment No. 1 in Canada.

NOTE: **RESCO™** Tables are based on the GAMA Venting Tables, the NFGC Parts 7 and 11 in the U.S.A., and the NSCPGIC Part 7 and Amendment No. 1 in Canada.

**RESCO™
Table Application Chart**

VENT AND CONNECTOR TYPES		USE TABLE NO.	
		1-Stage Furnace	Water Heater
COMMON VENT			
Type-B Vent	Type-B Connector	1 or 2	9
	Single-Wall Connector	3 or 4	9
Masonry Chimney	Type-B Connector	5 or 6	9
	Single-Wall Connector	7 or 8	9
DEDICATED VENT			
Type-B Vent	Type-B Connector	10	N/A
	Single-Wall Connector	11	N/A
Masonry Chimney	Type-B Connector	NR	N/A
	Single-Wall Connector	NR	N/A

Manifolded Connector and Offset Vent (or Chimney) Application Requirement

CONNECTOR OR VENT INSIDE DIA (IN.)	4	5	6	7	8	9	10
RECTANGULAR LINER OUTSIDE DIMENSIONS (In.)	4 X 8	N/A	N/A	N/A	8 X 8	8 X 12	12 X 12
L—Maximum Horizontal Length (Ft)	6	7.5	9	10.5	12	13.5	15

N/A—Not Applicable

NOTE: Use as shown in Fig. 1, 2, 5, 6, 7, and 8.

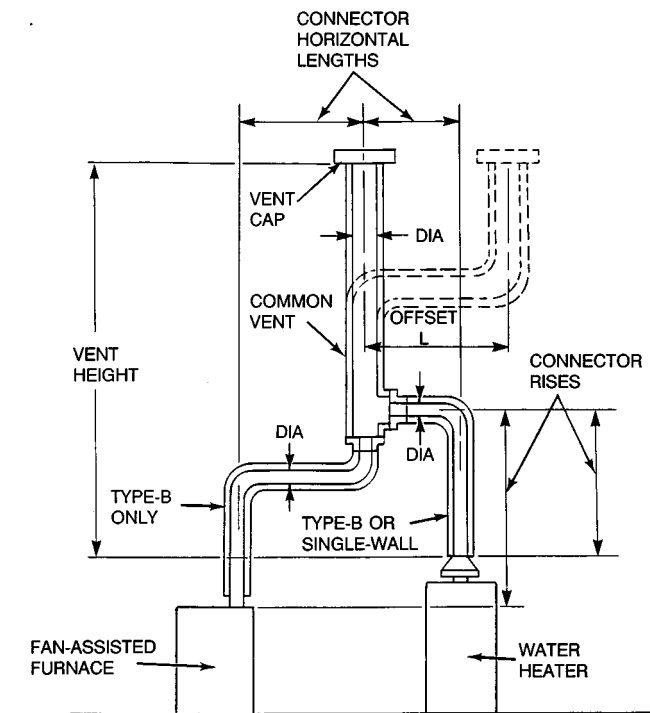

Fig. 1—Use With Tables 1 and 2

A91200

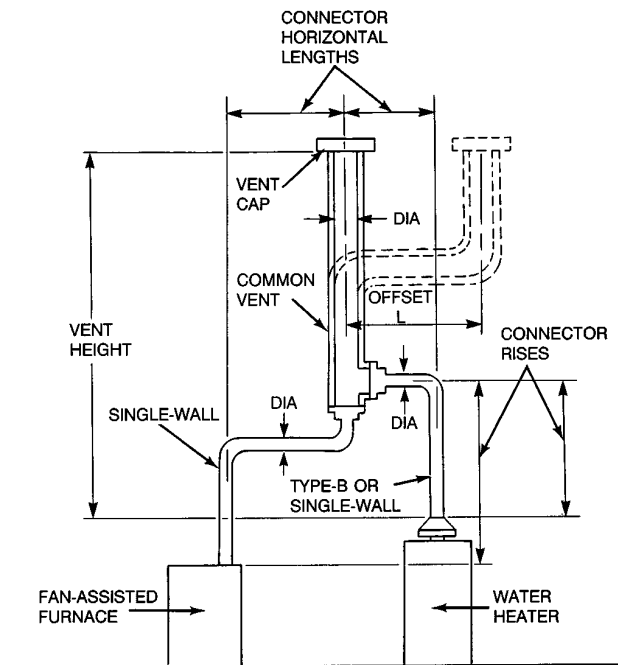

Fig. 2—Use With Tables 3 and 4

A91201

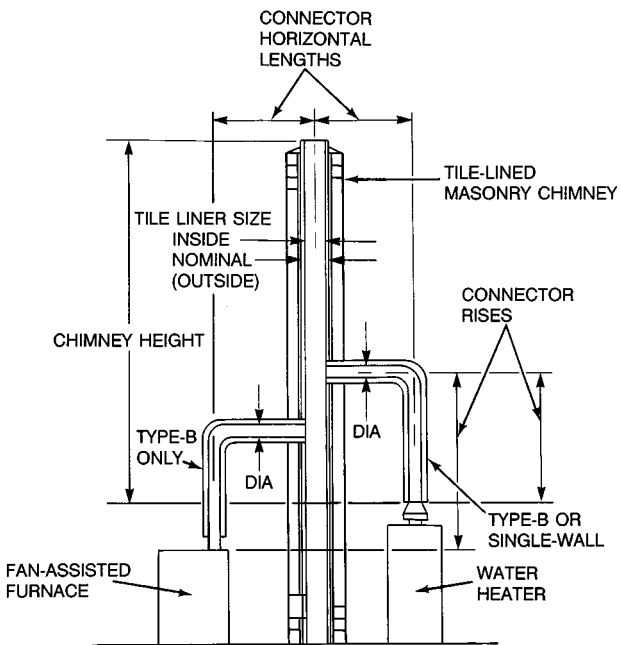

Fig. 3—Use With Tables 5 and 6

A91202

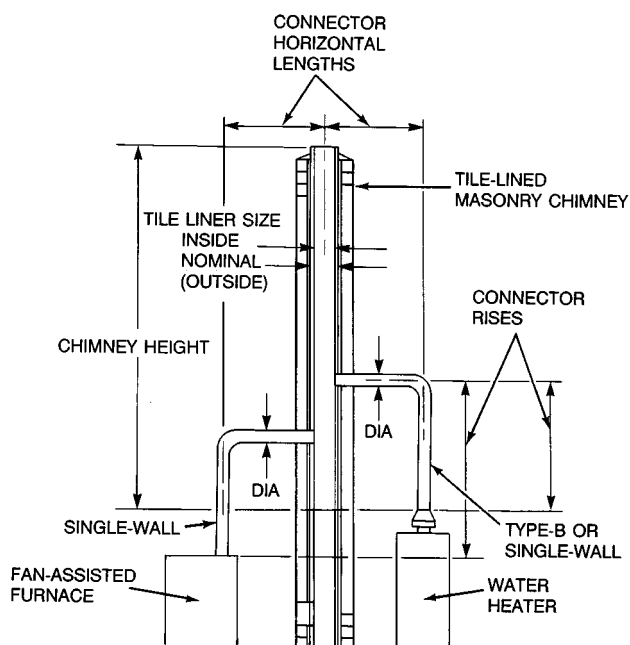
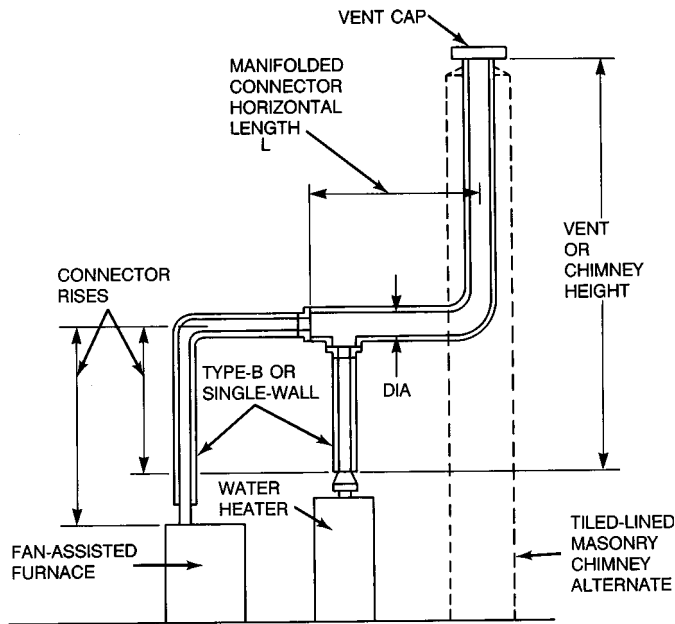

Fig. 4—Use With Tables 7 and 8

A91203



A91311

Fig. 5—Manifolded Vent Connectors for Use With Tables 1 through 8

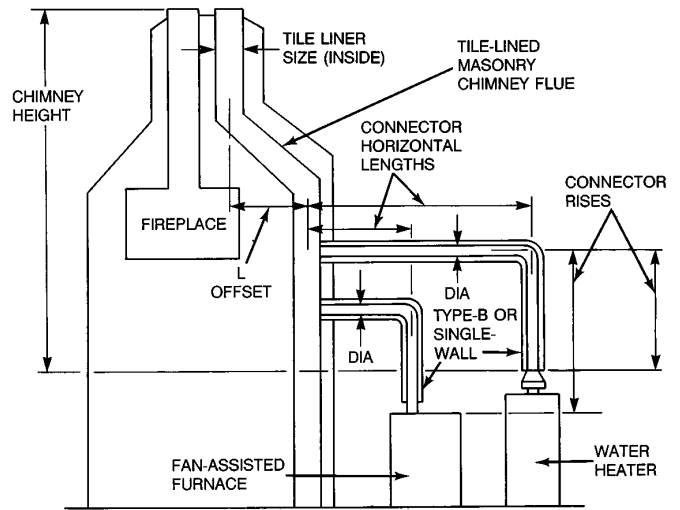

A91312

Fig. 6—Masonry Chimney Offset for Use With Tables 5 through 8

RESCO™ Table—1
Type-B Common Vent
Type-B Connector For Up To 2 Elbows

FURNACE INPUT (MBH)		42-46			63-69			84-92			105-115			126-138			147-154		
FLUE COLLAR SIZE (In.)		4			4			4			4			5			5		
CONNECTOR HORIZONTAL LENGTH (Ft)		0	4.5	9	0	6	12	0	6	12	0	6	12	0	7.5	15	0	7.5	15
		to	to	to	to	to	to	to	to	to	to	to	to	to	to	to	to	to	to
		4.5	9	13.5	6	12	18	6	12	18	6	12	18	7.5	15	22.5	7.5	15	22.5
Vent Height (Ft)	Connector Rise (Ft)	Fan-Assisted Furnace, Type-B Connector Inside Diameter (In.) With Up To 2 Elbows Common Vented With 1 Draft Hood-Equipped Water Heater With Up To 50 MBH Input																	
		10	1	4 D	4 D	4 D*	4 J	4 J*	NR	5 J	5 J*	NR	5 J	6 H*	NR	6 J	6 J*	NR	6 J
	2	4 B	4 B	4 B*	4 J	4 J*	NR	5 H	5 H*	NR	5 J	5 J*	NR	6 J	6 J*	NR	6 J	6 J*	NR
	3	4 B	4 B	4 B*	4 J	4 J*	NR	4 J	5 J*	NR	5 J	5 J*	NR	5 J	6 J*	NR	6 J	6 J*	NR
20	1	3 J	4 D	4 D	4 J	4 J	4 J	4 J	5 J	5 J	5 J	5 J	5 J	5 J	5 J	6 † J	5 J	6 J	6 † J
	2	3 J	4 D	4 D	4 J	4 J	4 J	4 J	4 J	5 J	5 J	5 J	5 J	5 J	5 J	6 † J	5 J	6 J	6 † J
	3	3 J	3 J	4 C	4 J	4 J	4 J	4 J	4 J	5 J	5 J	5 J	5 J	5 J	5 J	5 † J	5 J	5 J	6 † J
30	1	3 J	3 J	4 E	4 J	4 J	4 J	4 J	4 J	5 J	5 J	5 J	5 J	5 J	5 J	5 J	5 J	5 J	6 J
	2	3 J	3 J	4 D	4 J	4 J	4 J	4 J	4 J	4 J	4 J	5 J	5 J	5 J	5 J	5 J	5 J	5 J	6 J
	3	3 J	3 J	3 J	4 J	4 J	4 J	4 J	4 J	4 J	4 J	5 J	5 J	5 J	5 J	5 J	5 J	5 J	5 J
Vent Height (Ft)		TYPE-B DOUBLE-WALL COMMON VENT INSIDE DIAMETER (In.)																	
		Minimum																	
10		4 †			5 †			6 †			6 †			6 †			7		
20		4 †			4 †			5 †			5 †			6 †			6 †		
30		4			4 †			5			5 †			5 †			6		
Water Heater Draft Hood Outlet Dia	3 in. 4, 5, 6 in.	Maximum																	
		7			7			7			7			7			7		
		10			10			10			10			10			10		

RESCO™ Altitude Code Letters Table

MAXIMUM ALTITUDE ABOVE SEA LEVEL (FT)	0 TO 2000	3000	4000	5000	6000	7000	8000	9000	10,000
Letter Code	A	B	C	D	E	F	G	H	J

* Connector horizontal length shall not exceed 10 ft.

† Connector horizontal length shall not exceed 20 ft.

‡ Increase the common vent by 1 table size for manifolded connector and/or common vent offset. See Application Requirements No. 4 and 6. d.

NOTES:

1. The letter codes next to the connector sizes indicate the highest altitudes at which each connector shall be installed. See Application Requirement No. 3 and the Altitude Code Letters Table.

2. Refer to the RESCO™ Table Application Requirements in front of these tables for other application requirements.

RESCO™ Table—2
Type-B Common Vent
Type-B Connector For 3 Elbows

FURNACE INPUT (MBH)		42-46			63-69			84-92			105-115			126-138			147-154		
FLUE COLLAR SIZE (In.)		4			4			4			4			5			5		
CONNECTOR HORIZONTAL LENGTH (Ft)		0 to 4.5	4.5 to 9	9 to 13.5	0 to 6	6 to 12	12 to 18	0 to 6	6 to 12	12 to 18	0 to 6	6 to 12	12 to 18	0 to 7.5	7.5 to 15	15 to 22.5	0 to 7.5	7.5 to 15	15 to 22.5
Vent Height (Ft)	Connector Rise (Ft)	Fan-Assisted Furnace, Type-B Connector Inside Diameter (In.) With 3 Elbows Common Vented With 1 Drafthood-Equipped Water Heater With Up To 50 MBH Input																	
10	1	4 D	4 D	4 D*	4 J	5 D*	NR	5 J	5 J*	NR	6 H	6 H*	NR	6 H	6 J*	NR	6 J	7 H*	NR
	2	4 B	4 B	4 B*	4 J	4 J*	NR	5 H	5 H*	NR	5 J	6 H*	NR	6 H	6 J*	NR	6 J	6 J*	NR
	3	4 B	4 B	4 B*	4 J	4 J*	NR	5 J	5 J*	NR	5 J	5 J*	NR	6 J	6 J*	NR	6 J	6 J*	NR
20	1	4 D	4 D	4 D	4 J	4 J	4 J	5 J	5 J	5 J	5 J	5 J	6 J	5 J	6 J	6† J	6 J	6 J	6† J
	2	4 D	4 D	4 D	4 J	4 J	4 J	4 J	5 J	5 J	5 J	5 J	5 J	5 J	6 J	6† J	6 J	6 J	6† J
	3	3 J	4 C	4 C	4 J	4 J	4 J	4 J	5 J	5 J	5 J	5 J	5 J	5 J	5 J	6† J	5 J	6 J	6† J
30	1	3 J	4 E	4 E	4 J	4 J	4 J	4 J	5 J	5 J	5 J	5 J	5 J	5 J	6 J	5 J	5 J	6 J	6 J
	2	3 J	4 D	4 D	4 J	4 J	4 J	4 J	4 J	5 J	5 J	5 J	5 J	5 J	5 J	5 J	5 J	6 J	6 J
	3	3 J	3 J	4 D	4 J	4 J	4 J	4 J	4 J	5 J	5 J	5 J	5 J	5 J	5 J	5 J	5 J	5 J	6 J
Vent Height (Ft)		TYPE-B DOUBLE-WALL COMMON VENT INSIDE DIAMETER (In.)																	
		Minimum																	
10		4‡			5‡			6‡			6‡			6‡			7		
20		4‡			4‡			5‡			6			6‡			6‡		
30		4			4‡			5			5‡			6			6		
		Maximum																	
Water Heater Drafthood Outlet Dia	3 in.	7			7			7			7			7			7		
	4, 5, 6 in.	10			10			10			10			10			10		

RESCO™ Table—3
Type-B Common Vent
Single-Wall Connector For Up To 2 Elbows

FURNACE INPUT (MBH)		42-46			63-69			84-92			105-115			126-138			147-154		
FLUE COLLAR SIZE (In.)		4			4			4			4			5			5		
CONNECTOR HORIZONTAL LENGTH (Ft)		0 to 4.5	4.5 to 9	9 to 13.5	0 to 6	6 to 12	12 to 18	0 to 6	6 to 12	12 to 18	0 to 6	6 to 12	12 to 18	0 to 7.5	7.5 to 15	15 to 22.5	0 to 7.5	7.5 to 15	15 to 22.5
Vent Height (Ft)	Connector Rise (Ft)	Fan-Assisted Furnace, Single-Wall Metal Connector Inside Diameter (In.) With Up To 2 Elbows Common Vented With 1 Drafthood-Equipped Water Heater With Up To 50 MBH Input																	
6	1	NR	NR	NR	NR	NR	NR	NR	NR	NR	NR	NR	NR	NR	NR	NR	NR	NR	NR
	2	NR	NR	NR	NR	NR	NR	NR	NR	NR	NR	NR	NR	NR	NR	NR	NR	NR	NR
	3	NR	NR	NR	NR	NR	NR	NR	NR	NR	NR	NR	NR	NR	NR	NR	NR	NR	NR
15	1	NR	NR	NR	NR	NR	NR	NR	NR	NR	NR	NR	NR	5 A	NR	NR	NR	NR	NR
	2	NR	NR	NR	NR	NR	NR	NR	4 A	NR	NR	NR	NR	5 A	NR	NR	NR	NR	NR
	3	NR	NR	NR	NR	NR	NR	NR	NR	NR	NR	NR	NR	NR	NR	5 B	NR	NR	NR
30	1	NR	NR	NR	NR	NR	NR	4 A	NR	NR	NR	NR	NR	5 A	5 A*	NR	5 D	5 D	NR
	2	NR	NR	NR	NR	NR	NR	4 A	NR	NR	NR	4 D	NR	5 A	5 A*	NR	5 D	5 D	NR
	3	NR	NR	NR	NR	NR	NR	NR	NR	NR	4 C	NR	NR	5 A	5 A*	NR	5 C	5 C	NR
Vent Height (Ft)		TYPE-B DOUBLE-WALL COMMON VENT INSIDE DIAMETER (In.)																	
		Minimum																	
6		NR			NR			NR			NR			NR			NR		
15		NR			NR			5†			NR			6†			6†		
30		NR			NR			5†			5†			5†			6†		
		Maximum																	
Water Heater Drafthood Outlet Dia	3 in.	NR			NR			7			7			7			7		
	4, 5, 6 in.	NR			NR			10			10			10			10		

RESCO™ Altitude Code Letters Table

MAXIMUM ALTITUDE ABOVE SEA LEVEL (FT)	0 TO 2000	3000	4000	5000	6000	7000	8000	9000	10,000
Letter Code	A	B	C	D	E	F	G	H	J

* Connector horizontal length shall not exceed 10 ft.

† Connector horizontal length shall not exceed 20 ft.

‡ Increase the common vent by 1 table size for manifolded connector and/or common vent offset. See Application Requirements No. 4 and 6. d.

NOTES:

1. The letter codes next to the connector sizes indicate the highest altitudes at which each connector shall be installed. See Application Requirement No. 3 and the Altitude Code Letters Table.

2. Refer to the RESCO™ Table Application Requirements in front of these tables for other application requirements.

RESCO™ Table—4
Type-B Common Vent
Single-Wall Connector For 3 Elbows

FURNACE INPUT (MBH)		42-46			63-69			84-92			105-115			126-138			147-154		
FLUE COLLAR SIZE (In.)		4			4			4			4			5			5		
CONNECTOR HORIZONTAL LENGTH (Ft)		0 to 4.5	4.5 to 9	9 to 13.5	0 to 6	6 to 12	12 to 18	0 to 6	6 to 12	12 to 18	0 to 6	6 to 12	12 to 18	0 to 7.5	7.5 to 15	15 to 22.5	0 to 7.5	7.5 to 15	15 to 22.5
Vent Height (Ft)	Connector Rise (Ft)	Fan-Assisted Furnace, Single-Wall Metal Connector Inside Diameter (In.) With 3 Elbows Common Vented With 1 Draft Hood-Equipped Water Heater With Up To 50 MBH Input																	
6	1	NR	NR	NR	NR	NR	NR	NR	NR	NR	NR	NR	NR	NR	NR	NR	NR	NR	NR
	2	NR	NR	NR	NR	NR	NR	NR	NR	NR	NR	NR	NR	NR	NR	NR	NR	NR	NR
	3	NR	NR	NR	NR	NR	NR	NR	NR	NR	NR	NR	NR	NR	NR	NR	NR	NR	NR
15	1	NR	NR	NR	NR	NR	NR	NR	NR	NR	NR	NR	NR	NR	NR	NR	NR	NR	NR
	2	NR	NR	NR	NR	NR	NR	NR	NR	NR	NR	NR	NR	NR	NR	NR	NR	NR	NR
	3	NR	NR	NR	NR	NR	NR	NR	NR	NR	NR	NR	NR	NR	NR	NR	NR	NR	NR
30	1	NR	NR	NR	NR	NR	NR	NR	NR	NR	NR	NR	NR	NR	NR	NR	5 A	NR	NR
	2	NR	NR	NR	NR	NR	NR	NR	NR	NR	NR	NR	NR	NR	NR	NR	5 A	NR	NR
	3	NR	NR	NR	NR	NR	NR	NR	NR	NR	NR	NR	NR	NR	NR	NR	5 A	NR	NR
Vent Height (Ft)		TYPE-B DOUBLE-WALL COMMON VENT INSIDE DIAMETER (In.)																	
		Minimum																	
6 15 30		NR			NR			NR			NR			NR			NR		
		NR			NR			NR			NR			NR			NR		
		NR			NR			NR			NR			5†			6†		
Water Heater Draft Hood Outlet Dia		Maximum																	
3 in. 4, 5, 6 in.		NR			NR			NR			NR			7			7		
		NR			NR			NR			NR			10			10		
		NR			NR			NR			NR			10			10		

† Increase the common vent by 1 table size for manifolded connector and/or common vent offset. See Application Requirements No. 4 and 6, d.

RESCO™ Table—5
Tile-Lined Masonry Chimney Common Vented
Type-B Connector For Up To 2 Elbows

FURNACE INPUT (MBH)		42-46			63-69			84-92			105-115			126-138			147-154		
FLUE COLLAR SIZE (In.)		4			4			4			4			5			5		
CONNECTOR HORIZONTAL LENGTH (Ft)		0 to 4.5	4.5 to 9	9 to 13.5	0 to 6	6 to 12	12 to 18	0 to 6	6 to 12	12 to 18	0 to 6	6 to 12	12 to 18	0 to 7.5	7.5 to 15	15 to 22.5	0 to 7.5	7.5 to 15	15 to 22.5
Chimney Height (Ft)	Connector Rise (Ft)	Fan-Assisted Furnace, Type-B Connector Inside Diameter (In.) With Up To 2 Elbows Common Vented With 1 Draft Hood-Equipped Water Heater With Up To 50 MBH Input																	
15	1	NR	NR	NR	4 J	4 J	NR	4 J	5 H	NR	5 J	5 J	NR	5 J	5 J	NR	5 J	6 J	NR
	2	3 J	NR	NR	4 H	4 H	NR	4 J	4 J	NR	5 J	5 J	NR	5 J	5 J	NR	5 J	5 J	NR
	3	3 H	3 H	NR	4 G	4 G	NR	4 J	4 J	NR	4 J	5 J	NR	5 J	5 J	NR	5 J	5 J	NR
30	1	3 J	NR	NR	4 J	4 J	4 J	4 J	4 J	5 H	5 J	5 J	5 J	5 J	5 J	5 J	5 J	5 J	6 J
	2	3 J	3 J	NR	4 J	4 J	4 J	4 J	4 J	4 J	4 J	5 J	5 J	5 J	5 J	5 J	5 J	5 J	5 J
	3	3 H	3 H	NR	4 H	4 H	4 H	4 J	4 J	4 J	4 J	4 J	5 J	5 J	5 J	5 J	5 J	5 J	5 J
50	1	3 J	NR	NR	4 J	4 J	4 J	4 J	4 J	4 J	4 J	5 J	5 J	5 J	5 J	5 J	5 J	5 J	5 J
	2	3 J	3 J	NR	4 J	4 J	4 J	4 J	4 J	4 J	4 J	5 J	5 J	5 J	5 J	5 J	5 J	5 J	5 J
	3	3 H	3 H	NR	4 H	4 H	4 H	4 J	4 J	4 J	4 J	4 J	5 J	5 J	5 J	5 J	5 J	5 J	5 J
Clay-Tile Chimney Liner		LINER NOMINAL RECTANGULAR DIMENSIONS (OUTSIDE) OR CIRCULAR INSIDE DIAMETER (In.)																	
		Minimum																	
		8 X 8 or 6 Dia*			8 X 8 or 6 Dia*			8 X 8 or 6 Dia*			8 x 8 or 7 Dia*			8 X 8 or 7 Dia*			8 X 8 or 7 Dia*		
Water Heater Draft Hood Outlet Dia		Maximum																	
3 in. 4, 5, 6 in.		8 X 8 or 7 Dia			8 X 8 or 7 Dia			8 X 8 or 7 Dia			8 X 8 or 7 Dia			8 X 8 or 7 Dia			8 X 8 or 7 Dia		
		12 X 12 or 10 Dia			12 X 12 or 10 Dia			12 X 12 or 10 Dia			12 X 12 or 10 Dia			12 X 12 or 10 Dia			12 X 12 or 10 Dia		
		12 X 12 or 10 Dia			12 X 12 or 10 Dia			12 X 12 or 10 Dia			12 X 12 or 10 Dia			12 X 12 or 10 Dia			12 X 12 or 10 Dia		

* 8 X 12 or 8-in. diameter at 50-ft height.

RESCO™ Altitude Code Letters Table

MAXIMUM ALTITUDE ABOVE SEA LEVEL (FT)	0 TO 2000	3000	4000	5000	6000	7000	8000	9000	10,000
Letter Code	A	B	C	D	E	F	G	H	J

NOTES:

- The letter codes next to the connector sizes indicate the highest altitudes at which each connector shall be installed. See Application Requirement No. 3 and the Altitude Code Letters Table.
- Refer to the RESCO™ Table Application Requirements in front of these tables for other application requirements.

RESCO™ Table—6
Title-Lined Masonry Chimney Common Vented
Type-B Connector For 3 Elbows

FURNACE INPUT (MBH)		42-46			63-69			84-92			105-115			126-138			147-154		
FLUE COLLAR SIZE (In.)		4			4			4			4			5			5		
CONNECTOR HORIZONTAL LENGTH (Ft)		0 to 4.5	4.5 to 9	9 to 13.5	0 to 6	6 to 12	12 to 18	0 to 6	6 to 12	12 to 18	0 to 6	6 to 12	12 to 18	0 to 7.5	7.5 to 15	15 to 22.5	0 to 7.5	7.5 to 15	15 to 22.5
Chimney Height (Ft)	Connector Rise (Ft)	Fan-Assisted Furnace, Type-B Connector Inside Diameter (In.) With 3 Elbows Common Vented With 1 Draft Hood-Equipped Water Heater With Up To 50 MBH Input																	
15	1	NR	NR	NR	4 J	4 J	NR	5 H	5 H	NR	5 J	5 J	NR	5 J	6 J	NR	6 J	6 J	NR
	2	NR	NR	NR	4 H	4 H	NR	4 J	5 G	NR	5 J	5 J	NR	5 J	5 J	NR	5 J	6 J	NR
	3	3 H	NR	NR	4 G	4 G	NR	4 J	4 J	NR	5 J	5 J	NR	5 J	5 J	NR	5 J	6 J	NR
30	1	NR	NR	NR	4 J	4 J	5 C	4 J	5 H	5 H	5 J	5 J	5 J	5 J	5 J	6 J	5 J	6 J	6 J
	2	3 J	NR	NR	4 J	4 J	4 J	4 J	4 J	5 H	5 J	5 J	5 J	5 J	5 J	5 J	5 J	5 J	6 J
	3	3 H	NR	NR	4 H	4 H	4 H	4 J	4 J	5 G	4 J	5 J	5 J	5 J	5 J	5 J	5 J	5 J	5 J
50	1	NR	NR	NR	4 J	4 J	4 J	4 J	4 J	5 H	5 J	5 J	5 J	5 J	5 J	5 J	5 J	5 J	6 J
	2	3 J	NR	NR	4 J	4 J	4 J	4 J	4 J	5 H	5 J	5 J	5 J	5 J	5 J	5 J	5 J	5 J	5 J
	3	3 H	NR	NR	4 H	4 H	4 H	4 J	4 J	4 J	4 J	5 J	5 J	5 J	5 J	5 J	5 J	5 J	5 J
Clay-Tile Chimney Liner	LINER NOMINAL RECTANGULAR DIMENSIONS (OUTSIDE) OR CIRCULAR INSIDE DIAMETER (In.)																		
	Minimum																		
	8 X 8 or 6 Dia*			8 X 8 or 6 Dia*			8 X 8 or 6 Dia*			8 X 8 or 7 Dia*			8 X 8 or 7 Dia*			8 X 8 or 7 Dia*			
Water Heater Draft Hood Outlet Dia	Maximum																		
	3 in.			8 X 8 or 7 Dia			8 X 8 or 7 Dia			8 X 8 or 7 Dia			8 X 8 or 7 Dia			8 X 8 or 7 Dia			
	4, 5, 6 in.			12 X 12 or 10 Dia			12 X 12 or 10 Dia			12 X 12 or 10 Dia			12 X 12 or 10 Dia			12 X 12 or 10 Dia			

RESCO™ Table—7
Title-Lined Masonry Chimney Common Vented
Single-Wall Connector For Up To 2 Elbows

FURNACE INPUT (MBH)		42-46			63-69			84-92			105-115			126-138			147-154		
FLUE COLLAR SIZE (In.)		4			4			4			4			5			5		
CONNECTOR HORIZONTAL LENGTH (Ft)		0 to 4.5	4.5 to 9	9 to 13.5	0 to 6	6 to 12	12 to 18	0 to 6	6 to 12	12 to 18	0 to 6	6 to 12	12 to 18	0 to 7.5	7.5 to 15	15 to 22.5	0 to 7.5	7.5 to 15	15 to 22.5
Chimney Height (Ft)	Connector Rise (Ft)	Fan-Assisted Furnace, Single-Wall Metal Connector Inside Diameter (In.) With Up To 2 Elbows Common Vented With 1 Draft Hood-Equipped Water Heater With Up To 50 MBH Input																	
15	1	NR	NR	NR	NR	NR	NR	NR	NR	NR	NR	NR	NR	NR	NR	NR	NR	NR	NR
	2	NR	NR	NR	NR	NR	NR	NR	NR	NR	NR	NR	NR	NR	NR	NR	NR	NR	NR
	3	NR	NR	NR	NR	NR	NR	NR	NR	NR	NR	NR	NR	NR	NR	NR	NR	NR	NR
30	1	NR	NR	NR	NR	NR	NR	NR	NR	NR	NR	NR	NR	5 A	NR	NR	5 B	5 B	NR
	2	NR	NR	NR	NR	NR	NR	NR	NR	NR	NR	NR	4 B	NR	NR	NR	5 A	5 A	NR
	3	NR	NR	NR	NR	NR	NR	NR	NR	NR	NR	NR	4 A	NR	NR	NR	5 A	5 A	NR
50	1	NR	NR	NR	NR	NR	NR	NR	NR	NR	NR	NR	NR	5 A	NR	NR	5 B	5 B	NR
	2	NR	NR	NR	NR	NR	NR	NR	NR	NR	NR	NR	4 B	NR	NR	NR	5 A	5 A	NR
	3	NR	NR	NR	NR	NR	NR	NR	NR	NR	NR	NR	4 A	4 A	NR	NR	5 A	5 A	NR
Clay-Tile Chimney Liner	LINER NOMINAL RECTANGULAR DIMENSIONS (OUTSIDE) OR CIRCULAR INSIDE DIAMETER (In.)																		
	Minimum																		
	NR			NR			NR			8 X 8 or 7 Dia*			8 X 8 or 7 Dia*			8 X 8 or 7 Dia*			
Water Heater Draft Hood Outlet Dia	Maximum																		
	3 in.			NR			NR			NR			8 X 8 or 7 Dia			8 X 8 or 7 Dia			
	4, 5, 6 in.			NR			NR			NR			12 X 12 or 10 Dia			12 X 12 or 10 Dia			

RESCO™ Altitude Code Letters Table

MAXIMUM ALTITUDE ABOVE SEA LEVEL (FT)	0 TO 2000	3000	4000	5000	6000	7000	8000	9000	10,000
Letter Code	A	B	C	D	E	F	G	H	J

* 8 X 12 or 8-in. diameter at 50-ft height.

NOTES:

1. The letter codes next to the connector sizes indicate the highest altitudes at which each connector shall be installed. See Application Requirement No. 3 and the Altitude Code Letters Table.
2. Refer to the RESCO™ Table Application Requirements in front of these tables for other application requirements.

RESCO™ Table—8
Title-Lined Masonry Chimney Common Vented
Single-Wall Connector For 3 Elbows

FURNACE INPUT (MBH)		42-46			63-69			84-92			105-115			126-138			147-154		
FLUE COLLAR SIZE (In.)		4			4			4			4			5			5		
CONNECTOR HORIZONTAL LENGTH (Ft)		0 to 4.5	4.5 to 9	9 to 13.5	0 to 6	6 to 12	12 to 18	0 to 6	6 to 12	12 to 18	0 to 6	6 to 12	12 to 18	0 to 7.5	7.5 to 15	15 to 22.5	0 to 7.5	7.5 to 15	15 to 22.5
Chimney Height (Ft)	Connector Rise (Ft)	Fan-Assisted Furnace, Single-Wall Metal Connector Inside Diameter (In.) With 3 Elbows Common Vented With 1 Draft Hood-Equipped Water Heater With Up To 50 MBH Input																	
15	1	NR	NR	NR	NR	NR	NR	NR	NR	NR	NR	NR	NR	NR	NR	NR	NR	NR	NR
	2	NR	NR	NR	NR	NR	NR	NR	NR	NR	NR	NR	NR	NR	NR	NR	NR	NR	NR
	3	NR	NR	NR	NR	NR	NR	NR	NR	NR	NR	NR	NR	NR	NR	NR	NR	NR	NR
30	1	NR	NR	NR	NR	NR	NR	NR	NR	NR	NR	NR	NR	NR	NR	NR	NR	NR	NR
	2	NR	NR	NR	NR	NR	NR	NR	NR	NR	NR	NR	NR	NR	NR	NR	NR	NR	NR
	3	NR	NR	NR	NR	NR	NR	NR	NR	NR	NR	NR	NR	NR	NR	NR	NR	NR	NR
50	1	NR	NR	NR	NR	NR	NR	NR	NR	NR	NR	NR	NR	NR	NR	NR	NR	NR	NR
	2	NR	NR	NR	NR	NR	NR	NR	NR	NR	NR	NR	NR	NR	NR	NR	NR	NR	NR
	3	NR	NR	NR	NR	NR	NR	NR	NR	NR	NR	NR	NR	NR	NR	NR	NR	NR	NR
Clay-Tile Chimney Liner	LINER NOMINAL RECTANGULAR DIMENSIONS (OUTSIDE) OR CIRCULAR INSIDE DIAMETER (In.)																		
	Minimum																		
	NR			NR			NR			8 X 8 or 7 Dia*			NR			8 X 8 or 7 Dia*			
Water Heater Draft Hood Outlet Dia	Maximum																		
	NR			NR			NR			8 X 8 or 7 Dia			NR			8 X 8 or 7 Dia			
	NR			NR			NR			12 X 12 or 10 Dia			NR			12 X 12 or 10 Dia			

* 8 X 12 or 8-in. diameter at 50-ft height.

RESCO™ Altitude Code Letters Table

MAXIMUM ALTITUDE ABOVE SEA LEVEL (FT)	0 TO 2000	3000	4000	5000	6000	7000	8000	9000	10,000
Letter Code	A	B	C	D	E	F	G	H	J

NOTES:

1. The letter codes next to the connector sizes indicate the highest altitudes at which each connector shall be installed. See Application Requirement No. 3 and the Altitude Code Letters Table.

2. Refer to the RESCO™ Application Requirements in front of these tables for other application requirements.

RESCO™ Table—9
Connector For Water Heater Up To 50 MBH Input

WATER HTR INPUT (MBH)		30									40									50								
MAX NUMBER OF ELBOWS		2			3			4			2			3			4			2			3			4		
CONNECTOR HORIZONTAL LENGTH (Ft)		0 to 4.5	4.5 to 9	9 to 13	0 to 4.5	4.5 to 9	9 to 13	0 to 6	6 to 12	12 to 18	0 to 6	6 to 12	12 to 18	0 to 6	6 to 12	12 to 18	0 to 6	6 to 12	12 to 18	0 to 6	6 to 12	12 to 18	0 to 6	6 to 12	12 to 18	0 to 6	6 to 12	12 to 18
Chimney Height (Ft)	Connector Rise (Ft)	Draffhood-Equipped Water Heater, Single-Wall or Type-B Double-Wall Metal Connector Inside Diameter (In.)																										
		Common Vented With 1 Fan-Assisted Furnace																										
6	1	4	NR	NR	4	NR	NR	4	NR	NR	5	NR	NR	5	NR	NR	5	NR	NR	5	NR	NR	5	NR	NR	5	NR	NR
	2	4	NR	NR	4	NR	NR	4	NR	NR	4	NR	NR	4	NR	NR	4	NR	NR	4	NR	NR	4	NR	NR	4	NR	NR
	3	3*	NR	NR	3*	NR	NR	4	NR	NR	4	NR	NR	4	NR	NR	4	NR	NR	4	NR	NR	4	NR	NR	4	NR	NR
15	1	4	4	4	4	4	4	4	4	5†	4	5	5†	5	5	5†	5	5	5†	5	5	5†	5	5	5†	5	5	6†
	2	3*	4	4	4	4	4	4	4	4†	4	4	4†	4	4	4†	4	4	4†	4	4	4†	4	4	4†	4	4	5†
	3	3*	3*	4	3*	4	4	4	4	4†	4	4	4†	4	4	4†	4	4	4†	4	4	4†	4	4	4†	4	4	5†
30	1	4	4	4	4	4	4	4	4	5	4	4	5	4	5	5	5	5	5	5	5	5	5	5	5	5	5	6
	2	3*	4	4	4	4	4	4	4	4	4	4	4	4	4	4	4	4	4	4	4	4	4	4	4	4	5	5
	3	3*	3*	4	3*	4	4	4	4	4	4	4	4	4	4	4	4	4	4	4	4	4	4	4	4	4	4	5
50	1	4	4	4	4	4	4	4	4	5	4	4	5	4	5	5	5	5	5	5	5	5	5	5	5	5	5	6
	2	3*	4	4	4	4	4	4	4	4	4	4	4	4	4	4	4	4	4	4	4	4	4	4	4	4	5	5
	3	3*	3*	4	3*	4	4	4	4	4	4	4	4	4	4	4	4	4	4	4	4	4	4	4	4	4	4	5

* Three-in. diameter connectors are permitted only with water heaters which have 3-in. diameter draffhood outlets. Do not connect a 3-in. diameter connector to a 4-in. diameter or larger draffhood outlet.

† Connector horizontal length shall not exceed 15 ft.

NOTE: Refer to the RESCO™ Application Requirements in front of these tables for other application requirements.

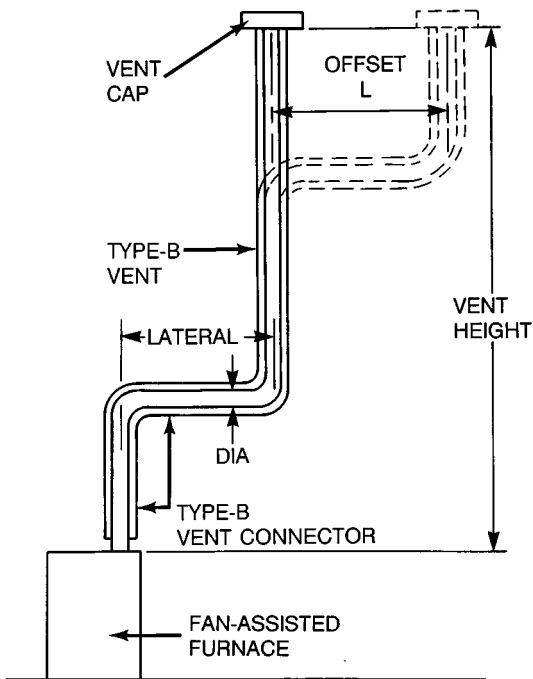

Fig. 7—Use With Table 10

A91204

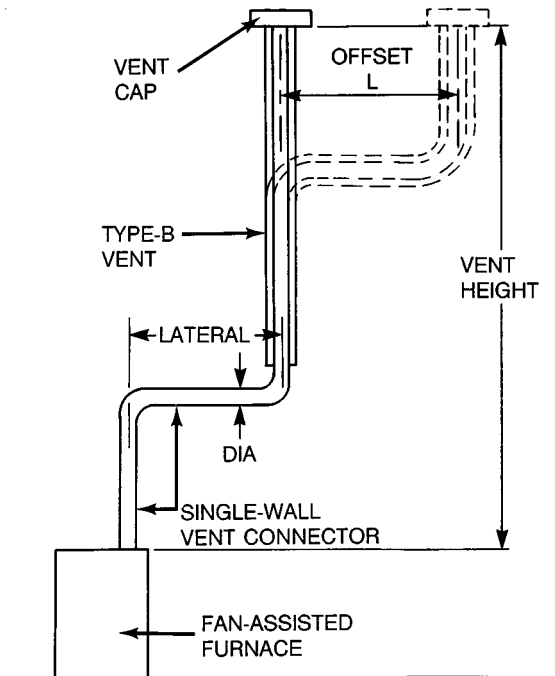

Fig. 8—Use With Table 11

A91205

**RESCO™ Table—10
Dedicated Vent**

Type-B Vent and Type-B Connector For Fan-Assisted Furnace

FURNACE INPUT (MBH)	42-46					63-69					84-92					105-115					126-138					147-154				
	4					4					4					4					5					5				
	2	3	4	5	Max Vent Dia (In.)	2	3	4	5	Max Vent Dia (In.)	2	3	4	5	Max Vent Dia (In.)	2	3	4	5	Max Vent Dia (In.)	2	3	4	5	Max Vent Dia (In.)	2	3	4	5	Max Vent Dia (In.)
TOTAL MAX NO. OF ELBOWS IN VENT AND CONNECTOR (No Elbows with Zero Lateral)	Conn Dia and Min Vent Dia (In.)					Conn Dia and Min Vent Dia (In.)					Conn Dia and Min Vent Dia (In.)					Conn Dia and Min Vent Dia (In.)					Conn Dia and Min Vent Dia (In.)					Conn Dia and Min Vent Dia (In.)				
	Lateral (Ft)					Lateral (Ft)					Lateral (Ft)					Lateral (Ft)					Lateral (Ft)					Lateral (Ft)				
	0	2	5	10	8J	3J	4J	4J	4J	4J	4J	4J	4J	4J	4J	4J	4J	4J	4J	4J	4J	4J	4J	4J	4J	4J	4J	4J	4J	4J
	0	2	5	10	8J	3J	3J	3J	3J	3J	4J	4J	4J	4J	4J	4J	4J	4J	4J	4J	4J	4J	4J	4J	4J	4J	4J	4J	4J	4J
10	3J	3J	3J	3J	4J	4J	4J	4J	4J	4J	4J	4J	4J	4J	4J	4J	4J	4J	4J	4J	4J	4J	4J	4J	4J	4J	4J	4J	4J	
20	3J	3J	3J	3J	4J	4J	4J	4J	4J	4J	4J	4J	4J	4J	4J	4J	4J	4J	4J	4J	4J	4J	4J	4J	4J	4J	4J	4J	4J	
30	3J	3J	3J	3J	4J	4J	4J	4J	4J	4J	4J	4J	4J	4J	4J	4J	4J	4J	4J	4J	4J	4J	4J	4J	4J	4J	4J	4J	4J	

RESCO™ Altitude Code Letters Table

MAXIMUM ALTITUDE ABOVE SEA LEVEL (FT)	0 TO 2000	3000	4000	5000	6000	7000	8000	9000	10,000
Letter Code	A	B	C	D	E	F	G	H	J

- NOTES:**
1. The letter codes next to the connector sizes indicate the highest altitudes at which each vent shall be installed. See Application Requirement No. 3 and the Altitude Code Letters Table.
2. Refer to the RESCO™ Application Requirements in front of these tables for other application requirements.

**RESCO™ Table—11
Dedicated Vent
Type-B Vent and Single-Wall Connector For Fan-Assisted Furnace**

FURNACE INPUT (MBH)		42-46					63-69					84-92					105-115					126-138					147-154				
FLUE COLLAR SIZE (In.)		4					4					4					4					5					5				
TOTAL MAX NO. OF ELBOWS IN VENT AND CONNECTOR (No Elbows with Zero Lateral)	Vent Height (Ft)	Lateral (Ft)	2	3	4	5	2	3	4	5	2	3	4	5	2	3	4	5	2	3	4	5	2	3	4	5	2	3	4	5	
			Conn Dia and Min Vent Dia (In.)	Max Vent Dia (In.)	Conn Dia and Min Vent Dia (In.)	Max Vent Dia (In.)	Conn Dia and Min Vent Dia (In.)	Max Vent Dia (In.)	Conn Dia and Min Vent Dia (In.)	Max Vent Dia (In.)	Conn Dia and Min Vent Dia (In.)	Max Vent Dia (In.)	Conn Dia and Min Vent Dia (In.)	Max Vent Dia (In.)	Conn Dia and Min Vent Dia (In.)	Max Vent Dia (In.)	Conn Dia and Min Vent Dia (In.)	Max Vent Dia (In.)	Conn Dia and Min Vent Dia (In.)	Max Vent Dia (In.)	Conn Dia and Min Vent Dia (In.)	Max Vent Dia (In.)	Conn Dia and Min Vent Dia (In.)	Max Vent Dia (In.)	Conn Dia and Min Vent Dia (In.)	Max Vent Dia (In.)	Conn Dia and Min Vent Dia (In.)	Max Vent Dia (In.)	Conn Dia and Min Vent Dia (In.)	Max Vent Dia (In.)	
10	0		3B	—	—	—	3J	—	—	—	4G	—	—	—	4J	—	—	—	4J	—	—	—	4J	—	—	—	4J	—	—	—	
	2		3A	3A	NR	NR	4A	4A	4F	4F	5A	5A	5A	5A	5A	5A	5A	5A	5A	5A	5A	5A	5A	5A	5A	5A	5A	5A	5A	5A	
	5		NR	NR	NR	NR	NR	NR	NR	NR	NR	NR	NR	NR	NR	NR	NR	NR	NR	NR	NR	NR	NR	NR	NR	NR	NR	NR	NR	NR	
	10		NR	NR	NR	NR	NR	NR	NR	NR	NR	NR	NR	NR	NR	NR	NR	NR	NR	NR	NR	NR	NR	NR	NR	NR	NR	NR	NR	NR	
20	0		3C	—	—	—	3J	—	—	—	4H	—	—	—	4J	—	—	—	4J	—	—	—	4J	—	—	—	4J	—	—	—	
	2		3B	3B	NR	NR	4A	4A	4G	4G	5A	5A	5A	5A	5A	5A	5A	5A	5A	5A	5A	5A	5A	5A	5A	5A	5A	5A	5A	5A	
	5		NR	NR	NR	NR	NR	NR	NR	NR	4B	4B	4B	4B	4F	4F	4F	4F	4F	4F	4F	4F	4F	4F	4F	4F	4F	4F	4F	4F	
	10		NR	NR	NR	NR	NR	NR	NR	NR	NR	NR	NR	NR	NR	NR	NR	NR	NR	NR	NR	NR	NR	NR	NR	NR	NR	NR	NR	NR	
	15		NR	NR	NR	NR	NR	NR	NR	NR	NR	NR	NR	NR	NR	NR	NR	NR	NR	NR	NR	NR	NR	NR	NR	NR	NR	NR	NR	NR	
20		NR	NR	NR	NR	NR	NR	NR	NR	NR	NR	NR	NR	NR	NR	NR	NR	NR	NR	NR	NR	NR	NR	NR	NR	NR	NR	NR	NR		
30	0		3D	—	—	—	3J	—	—	—	4C	—	—	—	4J	—	—	—	4J	—	—	—	4J	—	—	—	4J	—	—	—	
	2		3B	3B	NR	NR	4B	4B	4G	4G	5A	5A	5A	5A	5A	5A	5A	5A	5A	5A	5A	5A	5A	5A	5A	5A	5A	5A	5A	5A	
	5		NR	NR	NR	NR	NR	NR	NR	NR	4B	4B	4B	4B	4F	4F	4F	4F	4F	4F	4F	4F	4F	4F	4F	4F	4F	4F	4F	4F	
	10		NR	NR	NR	NR	NR	NR	NR	NR	NR	NR	NR	NR	NR	NR	NR	NR	NR	NR	NR	NR	NR	NR	NR	NR	NR	NR	NR	NR	
	15		NR	NR	NR	NR	NR	NR	NR	NR	NR	NR	NR	NR	NR	NR	NR	NR	NR	NR	NR	NR	NR	NR	NR	NR	NR	NR	NR	NR	
20		NR	NR	NR	NR	NR	NR	NR	NR	NR	NR	NR	NR	NR	NR	NR	NR	NR	NR	NR	NR	NR	NR	NR	NR	NR	NR	NR	NR		
30		NR	NR	NR	NR	NR	NR	NR	NR	NR	NR	NR	NR	NR	NR	NR	NR	NR	NR	NR	NR	NR	NR	NR	NR	NR	NR	NR	NR		

RESCO™ Altitude Code Letters Table

MAXIMUM ALTITUDE ABOVE SEA LEVEL (FT)	0 TO 2000	3000	4000	5000	6000	7000	8000	9000	10,000
Letter Code	A	B	C	D	E	F	G	H	J

- NOTES:**
1. The letter codes next to the connector sizes indicate the highest altitudes at which each vent shall be installed. See Application Requirement No. 3 and the Altitude Code Letters Table.
2. Refer to the RESCO™ Application Requirements in front of these tables for other application requirements.

EXAMPLE 1: COMMON VENTING INTO A MASONRY CHIMNEY

See Fig. 6. An 88,000 Btu/hr 1-stage, fan-assisted furnace with a 4-in. diameter flue collar is to be common vented with a 40,000 Btu/hr draft-hood-equipped water heater with a 4-in. diameter draft-hood outlet. The common vent is an existing 25-ft tall masonry chimney with 2 flues. The gas appliance flue is an 8- X 12-in. nominal size clay-tile liner with a 3-ft offset above the fireplace. The chimney flue is 6 ft from the water heater draft-hood outlet. The furnace flue collar is 3 ft from the chimney flue. The headroom above the furnace and water heater is 5 ft and 3 ft, respectively. Including entrance into the chimney, 3 elbows will be required to route each connector to the chimney.

CONNECTOR RISE: The water connector rise will be 2 ft to permit clearance to combustible construction. The furnace connector rise will be 3 ft to permit the furnace connector to enter the chimney below the water heater connector. (The water heater is 18 in. taller than the furnace.)

FURNACE CONNECTOR: Try to size single-wall connectors with tile-lined masonry chimney from Table 8. When trying to enter the table at 25 ft Chimney Height, the table skips from 15 to 30 ft. See Table Application Requirement No. 2 on page 5. Try 15 ft Chimney Height with 3 ft Connector Rise, and try 30 ft Chimney Height with 3 ft Connector Rise. Move across the table to the Furnace Input column 84-92 MBH and the Connector Horizontal Length column 0 to 6 ft. The connector sizes shown are NR and NR, which means that single-wall pipe is not recommended for this application.

Try Type-B connector pipe. Enter Table 6 in the same way as Table 8. At 15 ft Chimney Height, 3 ft of Connector Rise, and at 30 ft Chimney Height, 3 ft of Connector Rise for 84-92 MBH Furnace Input, and 0 to 6 ft of Connector Horizontal Length, Table 6 requires 4-in. and 4-in. Type-B connectors respectively. A 4-in. Type-B connector should be used because the entries above and below the 25 ft Chimney Height are both 4-in. connectors.

ALTITUDE LIMITATION: The code letter J next to the connector size 4 indicates the maximum altitude. If the gas input rate is properly derated, the Altitude Code Letters Table at bottom of page 10 indicates the maximum altitude at which this furnace connector size shall be used (10,000 ft above sea level in this instance).

MASONRY CHIMNEY: Continue down the same column to the Clay-Tile Chimney Liner Minimum and Maximum sizes, 8 X 8 and 12 X 12 in., respectively. The 8 X 12-in. nominal liner fits within that range. Check the table titled Manifolded Connector and Offset Vent (or Chimney). See table on page 5 for L-Maximum Horizontal Length in the 8- X 12-in. column. The 3-ft offset is less than the maximum horizontal length, 13.5 ft. If the connectors are joined before they enter the chimney flue as shown in Fig. 5, L-Maximum Manifolded Horizontal Connector Length is 9 ft for a 6-in. Type-B manifolded connector in the same table. Select the manifolded connector diameter, 6 in. from Table 6, Clay-Tile Chimney Liner Minimum and Maximum Circular Inside Diameter in the 84-92 MBH column, which permits 6- to 10-in. diameters.

WATER HEATER CONNECTOR: Enter Table 9 at 30 ft Chimney Height, 2 ft of Connector Rise, 40 MBH Water Heater Input, 3 Elbows, and 0 to 6 ft Connector Horizontal Length. A 4-in. diameter connector is required. Type-B and single-wall connector pipe are permitted.

No altitude restrictions apply to vent connectors for draft-hood-equipped water heaters or to common vents with a draft-hood-equipped water heater.

EXAMPLE 2: INTERPOLATION BETWEEN TABLE ENTRIES

Use the same installation as in Example 1 except when furnace connector rise is 1 ft instead of 3 ft. Determine the furnace connection size.

Enter Table 6. When trying to enter the table at 25 ft Chimney Height, the table skips from 15 to 30 ft. See Table Application Requirement No. 2 on page 5. Try 15 ft Chimney Height with 1 ft of Connector Rise, and try 30 ft Chimney Height with 1 ft of Connector Rise. Move across the table to the Furnace Input column 84-92 MBH and the Connector Horizontal Length column 0 to 6 ft. The connector sizes shown are 5 in. and 4 in., respectively. A 5-in. connector should be used because the Table Application Requirement No. 2.a. indicates to choose the larger of the connector sizes.

The code letters H and J next to connector sizes 5 and 4 indicate the maximum altitudes. Use the altitude code letter H for the chosen connector size (in this instance, 5 in.).

Installation Check Sheet

A. PRE-INSTALLATION

1. Proper Furnace Size

House heating load _____ Btuh

Furnace output capacity _____ Btuh

2. Chimney Inspection

Chimney condition _____

Chimney size (Flue Liner Inside and Outside Dimensions) _____

Common vent

Dedicated vent

Signs of condensation

Tile lined if masonry

3. Vent and Connector Sizing

Furnace input _____ Btuh

Furnace connector size/type Table _____ in./_____

Water heater less than 50 MBH

Water heater draft hood outlet diameter _____ in.

Water heater connector size/type (Table 9) _____ in./_____

Manifolded connector size/type (if required) _____ in./_____

Manifold length (if required) _____ ft

Offset length (if required) _____ ft

Vent size/type _____ in./_____

B. POST-INSTALLATION

1. Gas Input Rate Adjusted

_____ Btuh

2. Temperature Rise Set

Rating plate mid-point _____ F/_____ F

Furnace setting _____ F/_____ F

3. Thermostat Heat Anticipator

Setting amps _____

Three cycles per hr on electronic

4. Self-Test Operation OK