

GZ Series Geothermal System Sizes 024, 036, 048, 060, 072

Installation Instructions

NOTE: Read the entire instruction manual before starting the installation.

TABLE OF CONTENTS

	PAGE NO.
SAFETY CONSIDERATIONS	1
INSTALLATION RECOMMENDATIONS	2
APPLICATION CONSIDERATIONS	3
Geothermal Systems	3
Open Loop Well Water Systems	4
MATCHED SYSTEM	7
REFRIGERANT LINES	7
WATER PIPING	9
Loop Pump Connections	9
Water Solenoid Valves	9
Flow Regulator Valves	9
Typical Open Loop Piping	10
HRP Water Piping	11
ELECTRONIC THERMOSTAT INSTALLATION	12
Field Connections	12
ELECTRICAL	13
FACTORY INSTALLED FEATURES	15
Heat Recovery Package (HRP)	15
FIELD INSTALLED ACCESSORIES	15
Liquid Line Solenoid (LLS) Accessory	15
Outdoor Air Temperature Sensor (OAT)	16
Compressor Start Accessories	16
PRE START-UP CHECKLIST	17
UNIT START-UP	17
USER INTERFACE QUICK SET-UP	17
UI SYSTEM INITIAL POWER UP AND CHECKOUT	18
SYSTEM VERIFICATION	18
UPM SEQUENCE OF OPERATION FLOW CHART	18
SYSTEM FUNCTION & SEQUENCE OF OPERATION	20
Communication and Status Function Lights	20
Time Delays	20
Compressor Operation	20
Safety Devices and UPM Board	20
TIMER SPEEDUP/TEST MODE	22
AUXILIARY HEAT LOCKOUT	22
BLOWER PERFORMANCE DATA TABLE	23
WATER SIDE PRESSURE DROP (PSIG) TABLE	24
OPERATING TEMP. AND PRESSURES TABLES	25
TROUBLESHOOTING	30
Fault Code Table	30
Troubleshooting Units for Proper Switching Between Low & High Stages	31
Systems Communication Failure	31
MODEL PLUG	31
SERVICE TOOL	32
HRP TROUBLESHOOTING	32
10K TEMPERATURE SENSOR RESISTANCE TABLE	33
MAINTENANCE	34

Information in these installation instructions pertains only to GZ series units.

SAFETY CONSIDERATIONS

Improper installation, adjustment, alteration, service, maintenance, or use can cause explosion, fire, electrical shock, or other conditions which may cause death, personal injury, or property damage. Consult a qualified installer, service agency, or your distributor or branch for information or assistance. The qualified installer or agency must use factory-authorized kits or accessories when modifying this product. Refer to the individual instructions packaged with the kits or accessories when installing.

Follow all safety codes. Wear safety glasses, protective clothing, and work gloves. Use quenching cloth for brazing operations. Have fire extinguisher available. Read these instructions thoroughly and follow all warnings or cautions included in literature and attached to the unit. Consult local building codes and current editions of the National Electrical Code (NEC) NFPA 70. In Canada, refer to current editions of the Canadian electrical code CSA 22.1.

Recognize safety information. This is the safety-alert symbol . When you see this symbol on the unit and in instructions or manuals, be alert to the potential for personal injury. Understand these signal words; DANGER, WARNING, and CAUTION. These words are used with the safety-alert symbol. DANGER identifies the most serious hazards which **will** result in severe personal injury or death. WARNING signifies hazards which **could** result in personal injury or death. CAUTION is used to identify unsafe practices which **would** result in minor personal injury or product and property damage. NOTE is used to highlight suggestions which **will** result in enhanced installation, reliability, or operation.

WARNING

ELECTRICAL SHOCK HAZARD

Failure to follow this warning could result in personal injury or death.

Before installing, modifying, or servicing system, main electrical disconnect switch must be in the OFF position. There may be more than 1 disconnect switch. Lock out and tag switch with a suitable warning label.

WARNING

UNIT OPERATION AND SAFETY HAZARD

Failure to follow this warning could result in personal injury or equipment damage.

Puron® refrigerant systems operate at higher pressures than standard R-22 systems. Do not use R-22 service equipment or components on Puron® refrigerant equipment.

⚠ WARNING

EXPLOSION HAZARD

Failure to follow this warning could result in death, serious personal injury, and/or property damage.

Never use air or gases containing oxygen for leak testing or operating refrigerant compressors. Pressurized mixtures of air or gases containing oxygen can lead to an explosion.



⚠ CAUTION

CUT HAZARD

Failure to follow this caution may result in personal injury.

Sheet metal parts may have sharp edges or burrs. Use care and wear appropriate protective clothing and gloves when handling parts.

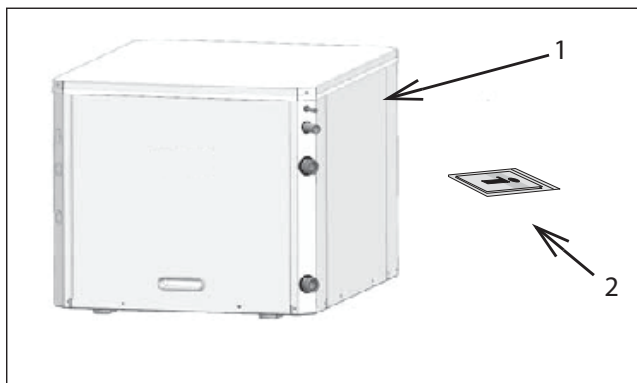

1. GZ Series Water-To Air Split System
2. Packet containing: Installation, Owner's Manual, Warranty Certificate and badges

A14176

Fig. 1 - Standard Package

INSTALLATION RECOMMENDATIONS

The Water-to-Air Heat Pumps are designed to operate with entering fluid temperature between 20°F to 90°F in the heating mode and between 30°F to 120°F in the cooling mode.

NOTE: 50°F minimum Entering Water Temperature (EWT) is recommended for well water applications with sufficient water flow to prevent freezing. Antifreeze solution is required for all closed loop applications. Geothermal applications should have sufficient antifreeze solution to protect against extreme conditions and equipment failure. Frozen water coils are not covered under warranty. Other equivalent methods of temperature control are acceptable.

Check Equipment and Job Site

Moving and Storage

If the equipment is not needed for immediate installation upon its arrival at the job site, it should be left in its shipping carton and stored in a clean, dry area. Units must only be stored or moved in the normal upright position as indicated by the "UP" arrows on each carton at all times.

⚠ CAUTION

EQUIPMENT DAMAGE HAZARD

Failure to follow this caution may result in equipment damage.

If unit stacking is required for storage, stack units as follows:
Do not stack units larger than 6 tons!
 Vertical units: less than 6 tons, no more than two high.
 Horizontal units: less than 6 tons, no more than three high.

Inspect Equipment

Be certain to inspect all cartons or crates on each unit as received at the job site before signing the freight bill. Verify that all items have been received and that there are no visible damages; note any shortages or damages on all copies of the freight bill. In the event of damage or shortage, remember that the purchaser is responsible for filing the necessary claims with the carrier. Concealed damages not discovered until after removing the units from the packaging must be reported to the carrier within 24 hours of receipt.

Location / Clearance

To maximize system performance, efficiency and reliability, and to minimize installation costs, it is always best to keep the refrigerant lines as short as possible. Every effort should be made to locate the air handler and the condensing section as close as possible to each other.

Serviceability should be a consideration and units should be placed so that installer and service technicians can access the service side of the unit with ease. The electrical box side of unit should maintain a clearance of 24" (609.6mm) minimum.

NOTE: Consider access to service parts before setting in place.

Condensing Section Location

Locate the condensing section in an area that provides sufficient room to make water and electrical connections and allows easy removal of the access panels in order for service personnel to perform maintenance or repair.

The condensing section is designed primarily for Indoor use. However, if installed in outside location where it could be subjected to freezing conditions the following conditions should be implemented:

- Freeze protection should be employed.
 - Freeze stat - To monitor water temp and start the loop pump if there is danger of freezing, even if there is no heating call.
 - Pump timer/starter or similar device
- Water lines entering and leaving the unit should be properly insulated prior to ground contact.

The GZ unit should be mounted level on a vibration absorbing pad slightly larger than the base to minimize vibration transmission to the building structure. It is not necessary to anchor the unit to the floor (see Fig. 2).

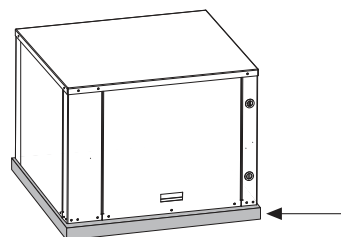

A14177

Fig. 2 - Vibration Pad Location

The vast majority of geothermal units are installed indoors and the condenser pads on the market are typically not designed for indoor equipment. Table 1 lists recommended pads (sold separately) designed for indoor packaged equipment. ACMP pads are made of 3/4" thick high density SBR recycled rubber, which provides a high degree of vibration and sound absorption for compressor bearing units installed indoors. These pads may be trimmed as needed.

Table 1 - Recommended Mounting Pads

Unit Size	Mounting Pad	Pad Dimensions
GZ024	ACMP2436	24" x 36"
GZ036	ACMP2436	24" x 36"
GZ048	ACMP2436	24" x 36"
GZ060	ACMP2836	28" x 36"
GZ072	ACMP2836	28" x 36"

Fan Coil or Furnace Location

Refer to the Fan Coil or Furnace Installation Manual for complete Details on indoor locations and clearances.

APPLICATION CONSIDERATIONS

Geothermal Systems

Closed loop and pond applications require specialized design knowledge. No attempt at these installations should be made unless the dealer has received specialized training.

Anti-freeze solutions are utilized when low evaporating conditions are expected to occur. Refer to the Flow Center installation manuals for more specific instructions. (See Fig. 3)

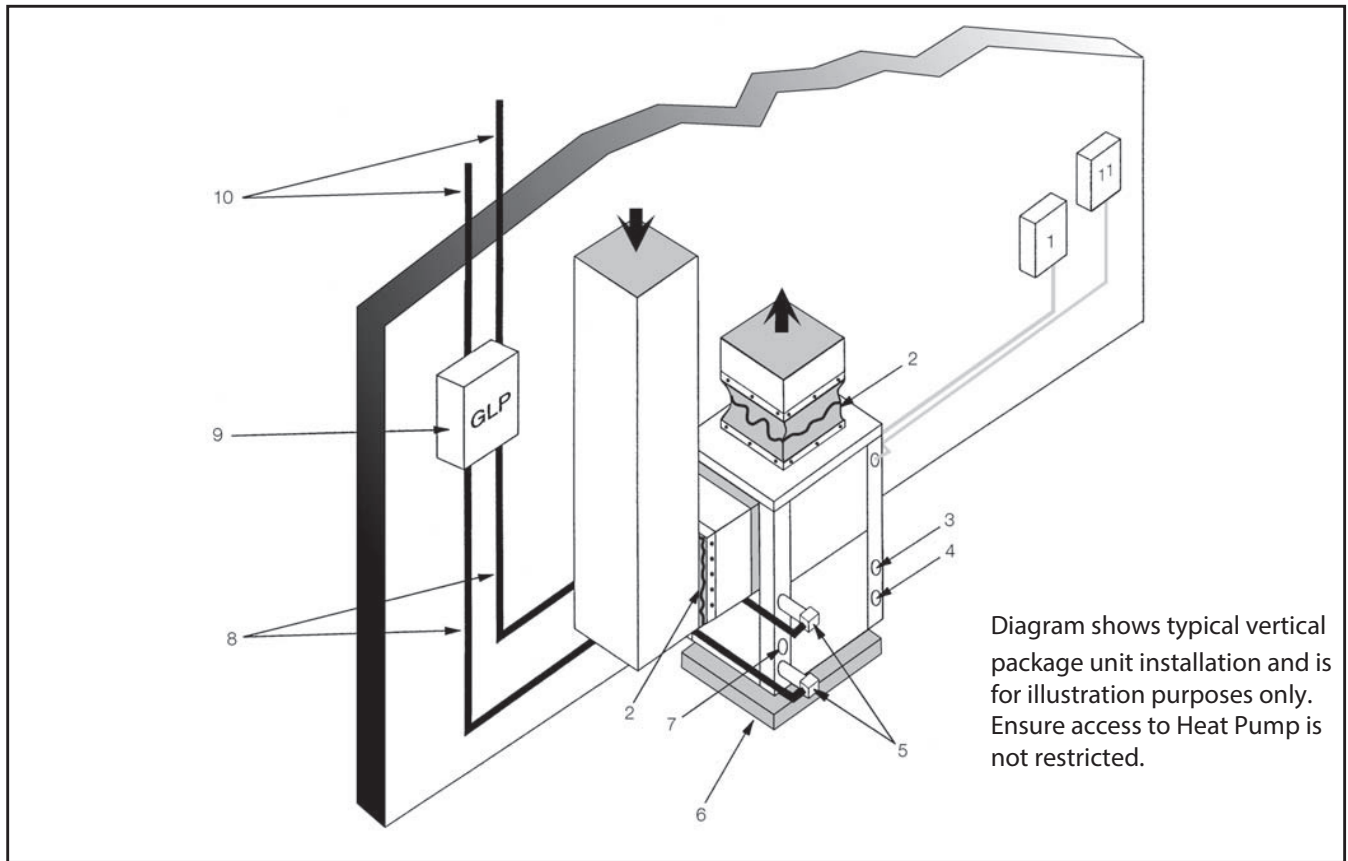

Note: Package unit shown. GZ unit is connected to furnace or fan coil (see page 6).

- (1) Line Voltage Disconnect (unit)
- (2) Flex Duct Connection
- (3) Low Voltage Control Connection
- (4) Line Voltage Connection
- (5) P/T Ports
- (6) Vibration Pad
- (7) Condensate Drain Connection
- (8) Ground Loop Connection Kit
- (9) Ground Loop Pumping Package
- (10) Polyethylene with Insulation
- (11) Line Voltage Disconnect (electric heater)

Fig. 3 - Example Geothermal System Setup

A14132

Open Loop Well Water Systems

IMPORTANT: Table 2 must be consulted for water quality requirements when using open loop systems. A water sample must be obtained and tested, with the results compared to the table. Scaling potential should be assessed using the pH/Calcium hardness method. If the pH is <7.5 and the calcium hardness is <100 ppm, the potential for scaling is low. For numbers out of the range listed, a monitoring plan must be implemented due to probable scaling.

Other potential issues such as iron fouling, corrosion, erosion and clogging must be considered. Careful attention to water conditions must be exercised when considering a well water application.

Failure to perform water testing and/or applying a geothermal heat pump to a water supply that does not fall within the accepted quality parameters will be considered a mis-application of the unit and resulting heat exchanger failures will not be covered under warranty. Where a geothermal system will be used with adverse water conditions, a suitable plate-frame heat exchanger **MUST** be used to isolate the well water from the geothermal unit.

Proper testing is required to assure the well water quality is suitable for use with water source equipment.

In conditions anticipating moderate scale formation or in brackish water, a cupronickel heat exchanger is recommended. Copper is adequate for ground water that is not high in mineral content.

In well water applications, water pressure must always be maintained in the heat exchanger. This is accomplished by installing the water solenoid valve in the leaving / outlet water line.

When using a single water well to supply both domestic water and the heat pump, care must be taken to insure that the well can provide sufficient flow for both.

In well water applications, a slow closing solenoid valve must be used to prevent water hammer (hammering or stuttering sound in the pipeline). Solenoid valve should be connected across Y1 and COND on the interface board for all. Make sure that the VA draw of the valve does not exceed the contact rating of the thermostat. (See Fig. 4)

The water solenoid valve should be installed in the leaving water line. A flow regulator valve should be located after the solenoid to set the flow rate. The suggested flow rate is 1.5 GPM per ton if the Entering Water Temperature (EWT) is 50°F or above. If below 50°F EWT use 2 GPM per ton. Example, a 4 ton unit with 50°F EWT would require a 6 GPM flow regulator. This would be part # FR6 (Flow Regulator) and the 6 is the GPM. If example was with 48°F EWT part. Refer to the *Open Loop Accessories* section in the Geothermal System Components Catalog for more part numbers.

⚠ CAUTION

UNIT OPERATION HAZARD

Failure to follow this caution may result in equipment damage or improper operation.

Discharge air configuration change is not possible on Heat Pumps equipped with Electric Heat Option.

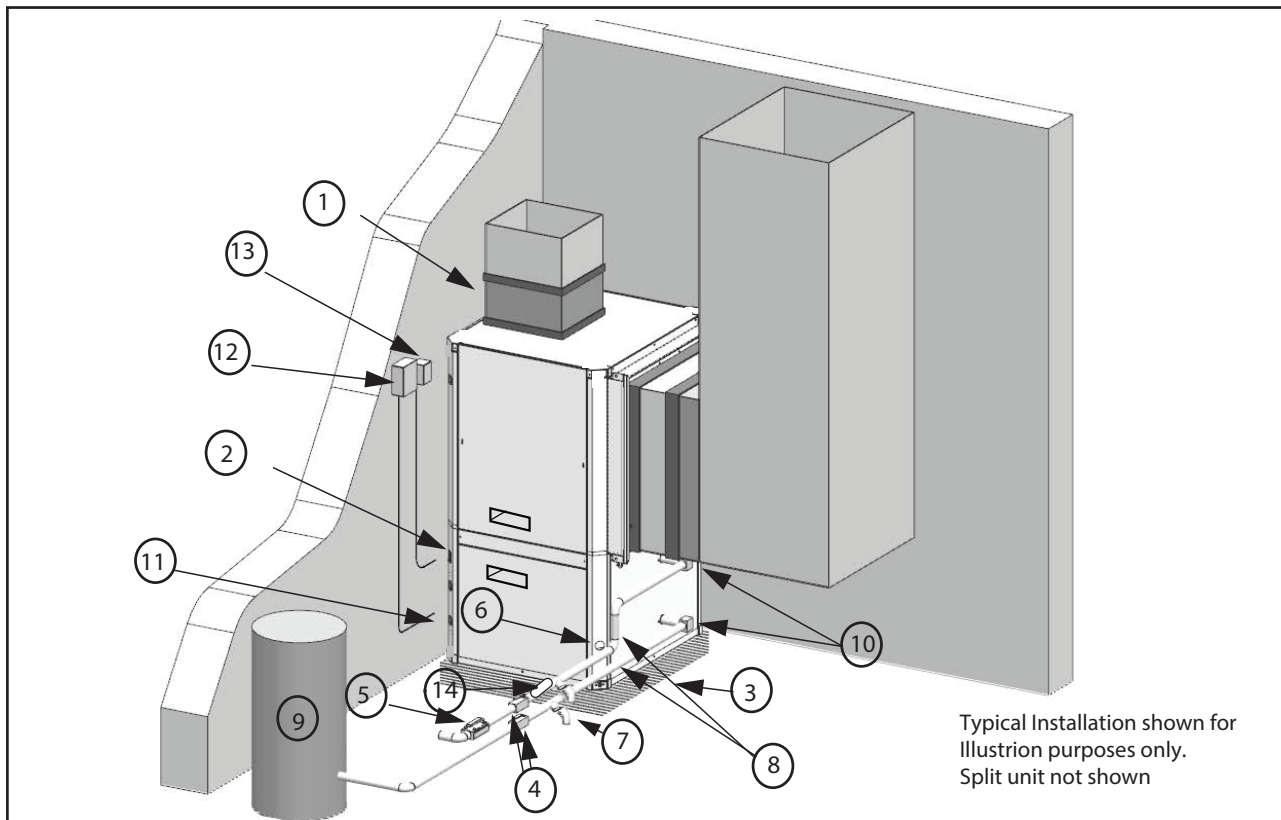

Note: Package unit shown. GZ unit is connected to furnace or fan coil (see page 6).

- | | |
|------------------------------------|--|
| (1) Flex Duct Connection | (8) Hose Kits (optional) |
| (2) Low Voltage Control Connection | (9) Pressure Tank (optional) |
| (3) Vibration Pad | (10) P/T Ports |
| (4) Ball Valves | (11) Line Voltage Connection |
| (5) Solenoid Valve Slow Closing | (12) Electric Heater Line Voltage Disconnect |
| (6) Condensate Drain Connection | (13) Unit Line Voltage Disconnect |
| (7) Drain Valves | (14) Flow Regulator |

Fig. 4 - Example Well Water System Setup

Table 2 – Water Quality Requirements for Open-Loop Geothermal Heat Pump System

Water Quality Parameter	HX Material	Closed Recirculating	Open Loop and Recirculating Well		
Scaling Potential - Primary Measurement Above the given limits, scaling is likely to occur. Scaling indexes should be calculated using the limits below:					
pH/Calcium Hardness Method	All	--	pH <7.5 and Ca Hardness <100ppm		
Index Limits for Probable Scaling Situations - (Operation outside these limits is not recommended) Scaling indexes should be calculated at 150°F for direct use and HWG applications, and at 90°F for indirect HX use. A monitoring plan should be implemented.					
Ryznar Stability Index	All	--	6.0 - 7.5 If > 7.5 minimize steel pipe use		
Langelier Saturation Index	All	--	-0.5 to +0.5 If <-0.5 minimize steel pipe use. Based upon 150°F HWG and Direct well, 84°F Indirect Well HX		
Iron Fouling					
Iron Fe ² (Ferrous) (Bacterial Iron Potential)	All	--	<0.2 ppm (Ferrous) If Fe ²⁺ (ferrous) >0.2 ppm with pH 6-8, O ₂ <5 ppm check for iron bacteria		
Iron Fouling	All	--	<0.5 ppm of Oxygen Above this level deposition will occur		
Corrosion Prevention					
pH	All	6 - 8.5 Monitor/treat as needed	6 - 8.5 Minimize steel pipe below 7 and no open tanks with pH <8		
Hydrogen Sulfide (H ₂ S)	All	--	At H ₂ S>0.2 ppm, avoid use of copper and copper nickel piping or HXs. Rotten egg smell appears at 0.5 ppm level. Copper alloy (bronze or brass) cast components are OK to <0.5 ppm		
Ammonia ion as hydroxide, chloride, nitrate and sulfate compounds	All	--	<0.5 ppm		
Maximum Chloride Levels			Maximum Allowable at Maximum Water Temperature		
			50°F	75°F	100°F
	Copper	--	<20 ppm	NR	NR
	cupronickel	--	<150 ppm	NR	NR
	304 SS	--	<400 ppm	<250 ppm	<150 ppm
	316 SS	--	<1000 ppm	<550 ppm	<375 ppm
			>1000 ppm	>550 ppm	>375 ppm
Erosion and Clogging					
Particulate Size and Erosion	All	<10 ppm of particles and a maximum velocity of 1.8 m/s. Filtered for maximum 841 micron [0.84 mm 20 mesh] size	<10 ppm (<1 ppm "sandfree" for reinjection) of particles and a maximum velocity of 1.8 m/s. Filtered for maximum 841 micron [0.84 mm. 20 mesh] size. Any particulate that is not removed can potentially clog components		

NOTES:

- Closed recirculating system is identified by a closed pressurized piping system.
- Recirculating open wells should observe the open recirculating design considerations.
- NR - application not recommended
- "—" No design Maximum

TYPICAL INSTALLATIONS

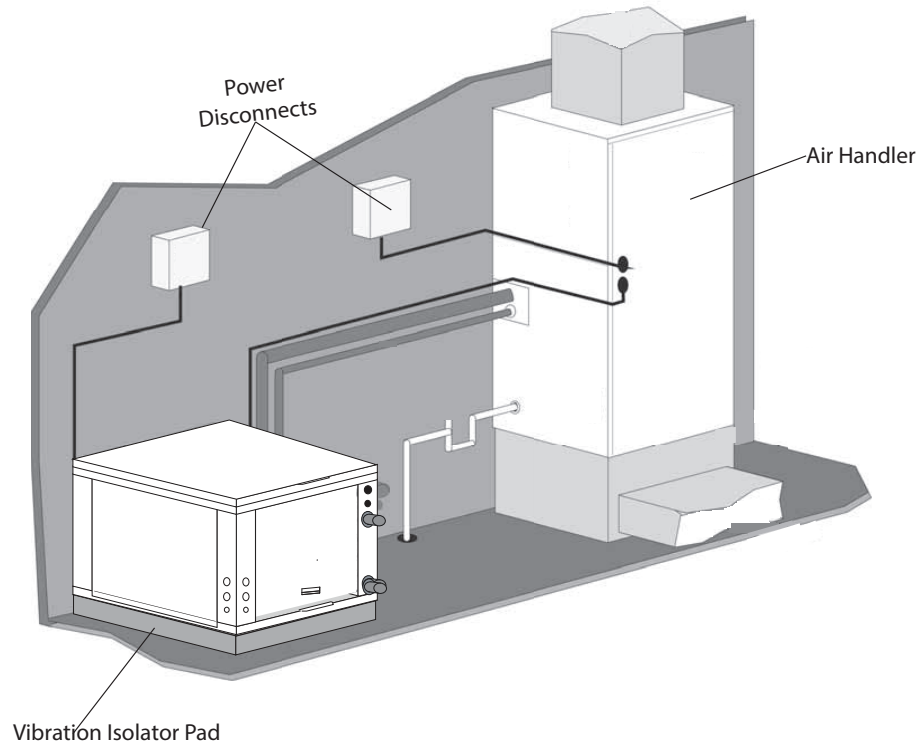

Fig. 5 - Typical Split with Air Handler Installation

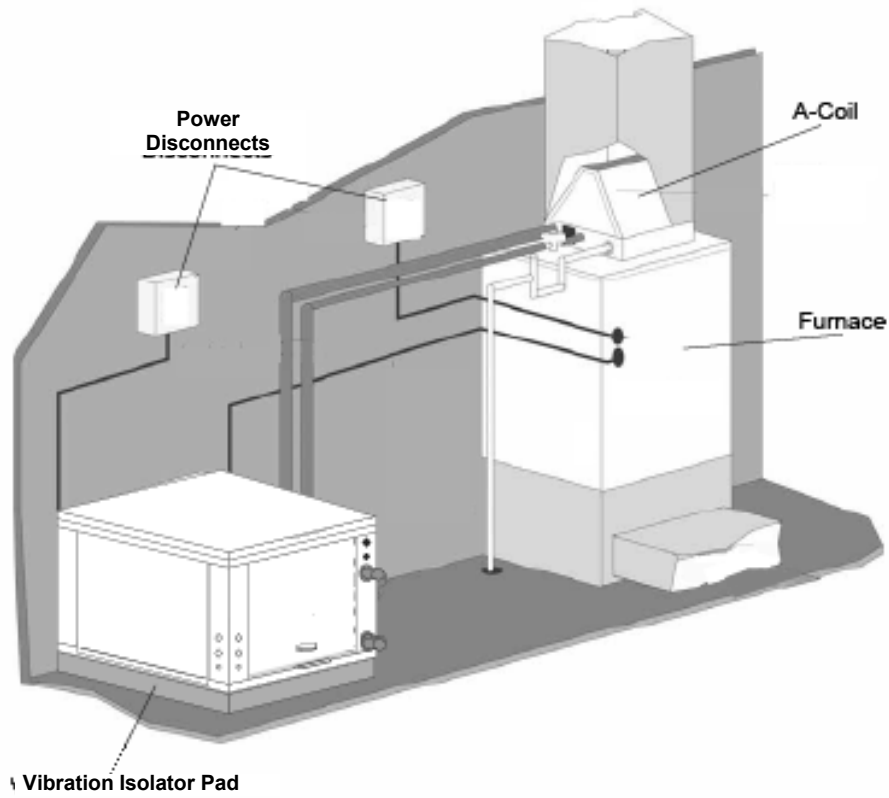

Fig. 6 - Typical Split with A-coil & Furnace Installation

MATCHED SYSTEM

The GZ geothermal splits have been tested and rated with Carrier & Bryant air handlers (fan coils) and evaporator coils (for use with furnaces).

Use air handler or cased coil from the list below and follow the Installation Instructions for those components.

Geothermal and Air Handler or Cased Coil Match-Up		
Geothermal Split	Air Handler	Cased Coil
GZ024	F(E/V)4***003, FB*024	C(A/N)P(V/M)P2417
GZ036	F(E/V)4***003, F(E/V)4***005	C(A/N)P(V/M)P3617
GZ048	F(E/V)4***005	C(A/N)P(V/M)P4821
GZ060	F(E/V)4***006	C(A/N)P(V/M)P6024
GZ072	F(E/V)4***006	C(A/N)P(V/M)P6024

When using the GZ unit with a furnace, it is important to match the CFM output of the furnace to the requirements of the GHP. For the GZ072, the selected furnace must achieve at least 2200 CFM.

NOTE: The Infinity/Evolution Control may not prevent the system from accepting a furnace with less airflow than required for the GZ072. This is the responsibility of the installer.

REFRIGERANT LINES



WARNING

PERSONAL INJURY / ENVIRONMENTAL HAZARD

Failure to follow this warning could result in personal injury or death.

Relieve pressure and recover all refrigerant before system repair or final unit disposal.

Use all service ports and open all flow-control devices, including solenoid valves.



CAUTION

ENVIRONMENTAL HAZARD

Failure to follow this caution may result in environmental damage.

Federal regulations require that you do not vent refrigerant to the atmosphere. Recover during system repair or final unit disposal.

The installation of the copper refrigerant tubing must be done with care to obtain reliable, trouble free operation. This installation should only be performed by qualified refrigeration service and installation personnel.

Refrigerant lines should be routed and supported so as to prevent the transmission of vibrations into the building structure. 75 feet as the maximum length of interconnecting refrigerant lines in split system heat pumps. Beyond 75 feet, system losses become substantial and the total refrigerant charge required can compromise the reliability and design life of the equipment.

Refrigerant lines should be sized in accordance with those listed in Table 3. Copper tubing must be clean and free of moisture and dirt or debris. The suction and liquid lines should be insulated with at least 3/8" wall, closed-cell foam rubber insulation or equivalent.

Table 3 – Valve Sizing Chart

Valve Sizing Chart			
Unit Size	Line Type	Valve Conn. Size	Allen Wrench Size
GZ024, 036	Suction	3/4	5/16
GZ048, 060, 072	Suction	7/8	5/16
All Valves	Liquid	3/8	5/16

Some points to consider are:

- Pressure drop (friction losses) in refrigerant suction lines reduces system capacity and increases power consumption by as much as 2% or more, depending on the line length, number of bends, etc. Pressure drop in liquid lines affects system performance to a lesser degree, provided that a solid column of liquid (no flash gas) is being delivered to the refrigerant metering device, and that the liquid pressure at the refrigerant metering device is sufficient to produce the required refrigerant flow.
- Oil is continually being circulated with the refrigerant so, oil return to the compressor is always a consideration in line sizing. Suction lines on split system heat pumps are also hot gas lines in the heating mode, but are treated as suction lines for sizing purposes. If the recommended suction lines sizes are used, there should be no problem with oil return.
- Vertical lines should be kept to a minimum. Vertical liquid lines will have a vertical liquid lift in either heating or cooling, and the weight of the liquid head is added to the friction loss to arrive at the total line pressure drop.
- Wherever possible, the air handler should be installed at a higher elevation than the condensing section to aid with oil return to the compressor.

Linear vs Equivalent Line Length

Linear Line Length - is the actual measured length of the line including bends. This is used to calculate the additional refrigerant charge that must be added to the system.

Equivalent Line Length - is the combination of the actual length of all the straight runs and the equivalent length of all bends valves and fittings in a particular line. The equivalent length of a bend, valve or fitting is equal to the length of a straight tube of the same diameter having the same pressure drop as the particular valve or fitting. The ASHRAE Fundamentals Handbook provides tables for determining the equivalent length of various bends, valves and fittings.

Connecting Refrigerant Lines

- Use only ACR grade copper tubing and keep ends sealed until joints are made.
- For best performance, select routing of refrigerant lines for minimum distance and least number of bends.
- Size lines in accordance with Table 5.
- Cut crimped ends off the air handler suction and liquid lines. Connect and braze lines to the air handler.

NOTE: The air handler is factory supplied with a holding charge of dry nitrogen.

- Connect and braze lines to service valves on the condensing section.



CAUTION

UNIT DAMAGE HAZARD

Failure to follow this caution may result in equipment damage or improper operation.

- Use a brazing shield
- Wrap service valves with wet cloth or heat sink material.
- Direct flame away from the valve body.
- Valve body temperature must remain below 250°F to protect the internal rubber "O" rings and seals.
- Use nitrogen purge while brazing.

Pressurize the refrigerant lineset and air handler to 150 lbs with dry nitrogen through the ports provided on the self service valves. Check lineset and unit connections for leaks. Once system integrity is verified, evacuate lineset and air handler with a good vacuum pump to 500 microns and hold for half hour.

IMPORTANT: Pumpdown must never be used with heat pumps.

After verifying system integrity, slowly open service valve to allow refrigerant to flow through system. Unit is pre-charged for 25' of line set. Refer to Tables 4, 5 and 6 to adjust and verify system charge accordingly.

Table 4 – Liquid Line Charge per Linear Ft.

Liquid Line Charge per Linear Ft.	
Liquid Line Size O.D.	R410A oz per ft.
1/4	.25
5/16	.44
3/8	.60
1/2	1.15
5/8	1.95

Table 5 – Refrigerant Charge, Line Sizing & Capacity Multipliers

Refrigerant Charge, Line Sizing and Capacity Multiplier Chart												
Model	Factory R410A Charge (oz)*	Refrigerant Line O.D. Size (Based on Equivalent Line Length)										Suction/Discharge Vapor Line
		25 Ft.		35 Ft.		45 Ft.		50 Ft.		75 Ft.		
		LIQ.	SUC	LIQ.	SUC	LIQ.	SUC	LIQ.	SUC	LIQ.	SUC	
GZ024	80	3/8	3/4	3/8	3/4	3/8	3/4	3/8	3/4	3/8	7/8	3/4
GZ036	86	3/8	3/4	3/8	3/4	3/8	3/4	3/8	7/8	3/8	7/8	3/4
GZ048	88	3/8	7/8	3/8	7/8	3/8	7/8	3/8	7/8	3/8	7/8	7/8
GZ060	115	3/8	1-1/8	3/8	1-1/8	3/8	1-1/8	3/8	1-1/8	3/8	1-1/8	7/8
GZ072	127	3/8	1-1/8	3/8	1-1/8	3/8	1-1/8	3/8	1-1/8	3/8	1-1/8	7/8
CAPACITY MULTIPLIER		1.00		.995		.990		.990		.980		
Example 1:						Example 2:						
Model GZ036 with 45 ft. of equivalent length of 3/8" O.D. Liquid Line. Total system charge = Factory charge + (45 ft – 25 ft) X .60 oz/ft. Total system charge = 86 oz + (20 ft x .60 oz/ft) = 98 oz. Additional 12 oz of R410A refrigerant required.						Model GZ060 with 10 ft. of equivalent length of 3/8" O.D. Liquid Line. Total system charge = Factory charge + (10 ft – 25 ft) X .60 oz/ft. Total system charge = 115 oz – (15 ft x .60 oz/ft) = 106 oz. Reduce charge 9 oz of R410A refrigerant is required.						
Line Set Limitations: A 20 ft. Differential is the recommended limit without special considerations. For installations with 20–40 ft. Differential, it is recommended to add a liquid line solenoid and, if the fan coil or furnace is above the GZ unit, add an inverted trap before line drop.												

Table 6 – Charge Adjustments When Paired with Air Handlers

Charge Adjustments for GZ condensing section when paired with air handlers (oz)									
Unit	CNPV2417	FV4CNF003 FE4CNF003	FB4CMF024	CNPVP3617	FV4CNF003 FE4CNF003	CNPVP4821	FV4CNF005L FE4CNF00FL	CNPVP6024	FV4CNF006 FE4CNF006
GZ024	-11	-7	-8	-	-	-	-	-	-
GZ036	-	-	-	0	0	-	-	-	-
GZ048	-	-	-	-	-	5	5	-	-
GZ060	-	-	-	-	-	-	-	-13	0
GZ070	-	-	-	-	-	-	-	-13	-6

Example: Model GZ048 condensing section paired with FV4CNF005L air handler with 45ft of equivalent length of 3/8" O.D liquid Line.
Total system charge = factory charge + (charge adjustments for air handler) + (45ft – 25 ft) x .60 oz/ft.
Total system charge = 88 oz + (5 oz) + (20ft x .60 oz/ft) = 105 oz.
Additional 17 oz of R410A refrigerant required.

WATER PIPING

Supply and return piping must be as large as the unit connections on the heat pump (larger on long runs).



CAUTION

UNIT OPERATION HAZARD

Failure to follow this caution may result in improper equipment operation.

Never use flexible hoses of a smaller inside diameter than that of the fluid connections on the unit.

GZ units are supplied with either a copper or optional cupronickel water coax coil. Copper is adequate for ground water that is not high in mineral content.

NOTE: Proper testing is recommended to assure the well water quality is suitable for use with water source equipment. When in doubt, use cupronickel. See Application Considerations notes on page 4.

In conditions anticipating moderate scale formation or in brackish water, a cupronickel heat exchanger is recommended.

Both the supply and discharge water lines will sweat if subjected to low water temperature. These lines should be insulated to prevent damage from condensation. All manual flow valves used in the system must be ball valves. Globe and gate valves must not be used due to high pressure drop and poor throttling characteristics.



CAUTION

EQUIPMENT DAMAGE AND/OR UNIT OPERATION HAZARD

Failure to follow this caution may result in equipment damage and/or improper operation.

Never exceed the recommended water flow rates as serious damage or erosion of the water-to-refrigerant heat exchanger could occur.

Always check carefully for water leaks and repair appropriately. Units are equipped with female pipe thread fittings.

NOTE: Teflon tape sealer should be used when connecting water piping connections to the units to insure against leaks and possible heat exchanger fouling.

NOTE: The unit is shipped with water connection O-rings. A 10 pack of O-rings (part #4026) can be ordered through Replacement Components Division (RCD).

IMPORTANT: Do not over-tighten connections.

Flexible hoses should be used between the unit and the rigid system to avoid possible vibration. Ball valves should be installed in the supply and return lines for unit isolation and unit water flow balancing (on open-loop systems).

Loop Pump Connections

Refer to the flow center installation manual for piping and wiring instructions.

When using a flow center containing a variable speed pump, kit #4129 is required.

Water Solenoid Valves

Open loop well water applications require a water solenoid valve. The purpose of the valve is to allow water to flow through the GHP only during operation.

For ground water/open loop installations, solenoid valves MVBR3F and MVBR4F are recommended due to its fast opening/slow closing timing feature (see Fig. 7). This valve will open in approximately 5 seconds. Solenoid valves that are slow opening are not recommended as water in the unit's coax may freeze during start-up of a heating call. A frozen coax is not covered under warranty. MVBR3 and MVBR4F valves are also slow closing to eliminate potential water hammer.

Information on the MVBR3F and MVBR4F valves is shown below.



Fig. 7 - Solenoid Valves

A150629

Table 7 – Water Solenoid Valves

Part Number	Description
MVBR3F	Valve, motorized solenoid, forged brass 3/4" FPT, 24V
MVBR4F	Valve, motorized solenoid, forged brass 1" FPT, 24V

Flow Regulator Valves

A flow regulator valve should be used in open loop / well water applications to set the flow rate through the heat pump. The lowest entering fluid temperature (EWT) expected should be used to determine the flow rate per ton. 1.5 GPM per ton is acceptable for 50°F (10°C) EWT or higher. 2 GPM per ton should be used if EWT is below 50°F (10°C). (See Fig. 8 and Table 8)



Fig. 8 - Flow Regulator

A150630

Table 8 – Flow Regulators

Part Number	Flow Regulator Valves
FR2	Valve, flow regulator, 3/4" FPT x 3/4" FPT, 2 GPM
FR3	Valve, flow regulator, 3/4" FPT x 3/4" FPT, 3 GPM
FR4	Valve, flow regulator, 3/4" FPT x 3/4" FPT, 4 GPM
FR5	Valve, flow regulator, 3/4" FPT x 3/4" FPT, 5 GPM
FR6	Valve, flow regulator, 3/4" FPT x 3/4" FPT, 6 GPM
FR7	Valve, flow regulator, 3/4" FPT x 3/4" FPT, 7 GPM

Typical Open Loop Piping

Open loop systems require a water solenoid valve to turn on the water when the heat pump compressor is energized, and to turn off the water when the compressor is off.

A slow-closing motorized valve (MVBR3F or MVBR4F) is recommended to help reduce water hammer. A flow regulator limits water flow to avoid using more water than the heat pump requires, which wastes water and increases pumping costs. A hose kit provides vibration isolation, as well as convenient fittings to install P/T (pressure/temperature) plugs for checking water

temperature and pressure drop at start-up and during troubleshooting.

Fig. 9 shows the typical piping arrangement for a single solenoid valve. For single speed heat pumps and smaller two-stage heat pumps (3 tons and smaller), one valve is typical. For larger two-stage heat pumps, there is an opportunity to save a significant amount of energy (and avoid wasting water) with the use of two solenoid valves, one for first stage, and both for second stage (Fig. 10).

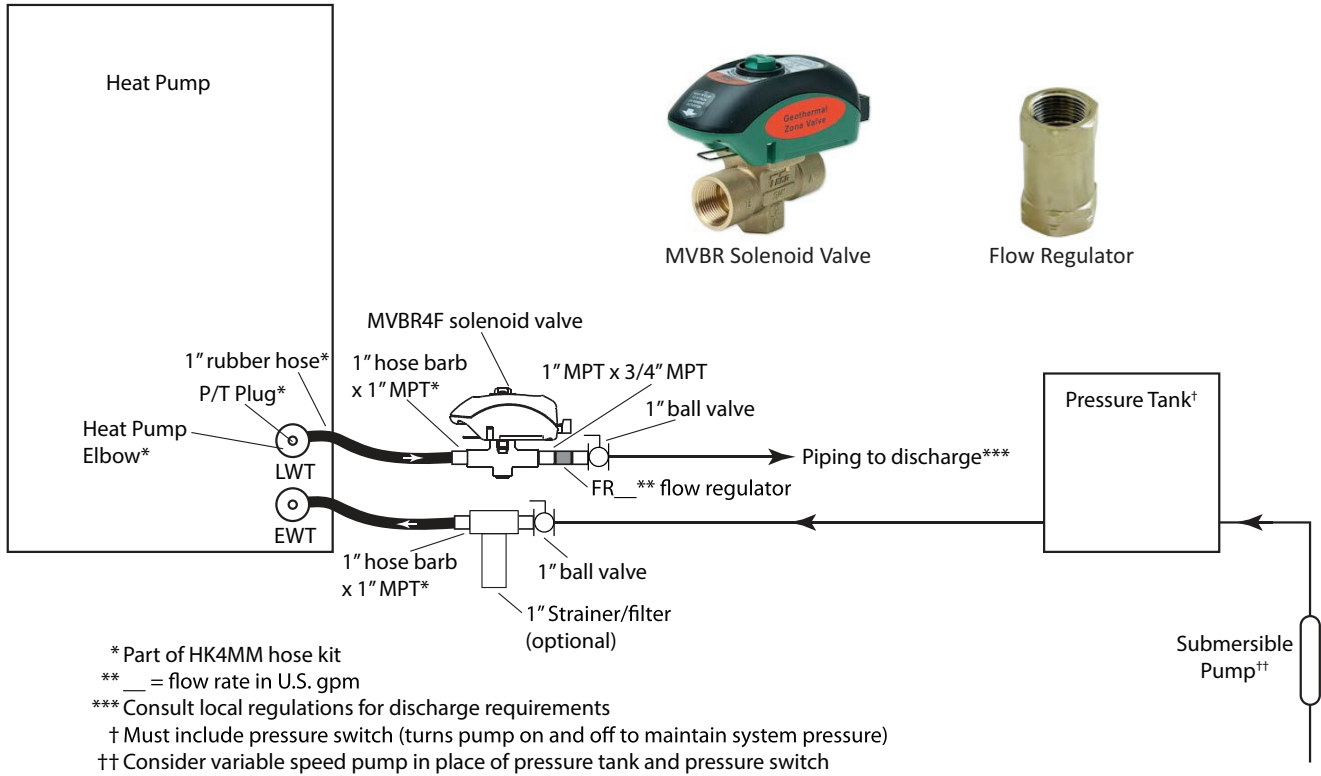
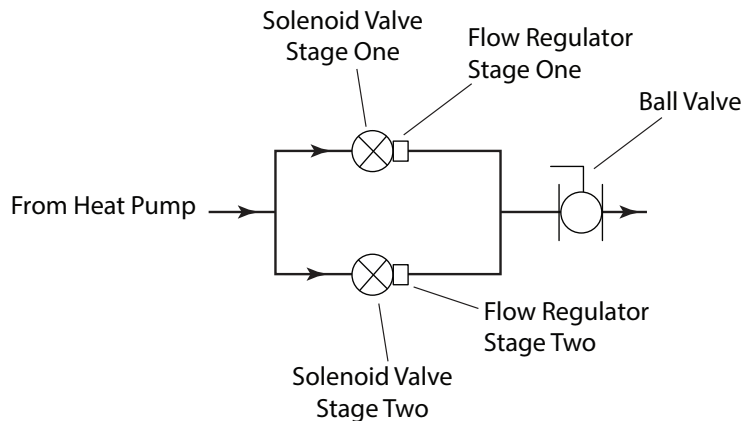

Fig. 9 - Single Solenoid Valve



NOTE: Refer to Fig. 18. Wiring kit #4129 is recommended for easy 24 volt connection staging solenoids with compressor.

Fig. 10 - Two Solenoid Valves

HRP Water Piping

All hot water piping **MUST** be a minimum of 5/8" O.D. copper tube to a maximum distance of 15 feet. For distances beyond 15 feet, but not exceeding 60 feet, use 1/2" copper tube. Separately insulate all exposed surface of both connecting water lines with 3/8" wall closed cell insulation. Install isolation valves on supply and return to the heat recovery. (See Fig. 11)

Water Tank Preparation

1. Turn off electrical or fuel supply to the water heater.
2. Attach garden hose to water tank drain connection and run other end of hose out doors or to an open drain.
3. Close cold water inlet valve to water heater tank.
4. Drain tank by opening drain valve on the bottom of the tank, then open pressure relief valve or hot water faucet.
5. Once drained the tank should be flushed with cold water until the water leaving the drain hose is clear and free of sediment.
6. Close all valves and remove the drain hose.
7. Install HR water piping.

Water Tank Refill

1. Open the cold water supply to the tank.
2. Open a hot water faucet to vent air from the system until water flows from the faucet, then close.
3. Depress the hot water tank pressure relief valve handle to ensure there is no air remaining in the tank.
4. Carefully inspect all plumbing for water leaks. Correct as required.
5. Using the air bleed valve, purge all air from water piping, allowing all air to bleed out until water appears at valve.
6. Before restoring the power or fuel supply to the water heater, adjust the temperature setting on the tank thermostat(s) to ensure maximum utilization of heat available from the refrigeration system and to conserve the most energy.

On tanks with thermostats and both upper and lower elements, the lower element should be turned down to 100°F, while the upper element should be adjusted to 120°F. Depending upon the specific needs of the customer, you may need to adjust the upper element differently.

On tanks with a single thermostat, lower the thermostat setting to 120°F or the "LOW" position. After thermostat adjustments are completed, replace access cover and restore electrical or fuel supply to water heater.

IMPORTANT: Copper should be used for piping from HRP to domestic water tank(s). Use 5/8" (16mm) O.D. copper or larger. Refer to local codes for hot water piping. Insulate the water lines between the GHP and the water heater with a minimum of 3/8" (10mm) closed cell insulation.

One Tank System

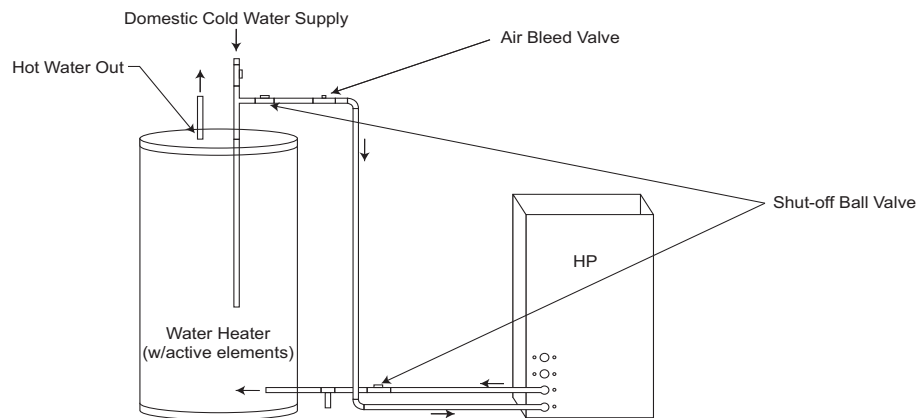

Two Tank System (preferred)

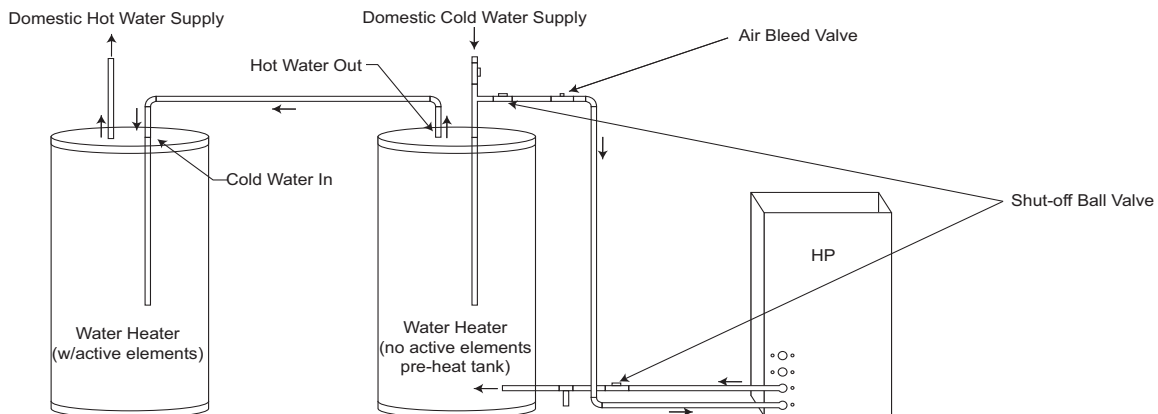

Package unit shown. GZ split unit arrangement similar with different water locations on unit.

Fig. 11 - HRP Water Piping

A150174

ELECTRONIC THERMOSTAT INSTALLATION

Field Connections

This section is intended as a quick reference only and should not replace a complete review of thermostat Installation Instructions.

The GZ unit can be installed as communicating or non-communicating with UI communicating or standard non-communicating thermostats.

Match	User Interface (UI) to GZ	Standard 2-stage Thermostat to GZ
FE	Yes	No
Communicating Furnace	Yes	Yes
Non-communicating Fan Coil	No	Yes
Non-communicating Furnace	No	Yes

NOTE: Matching geothermal systems with non-communicating indoor models will not offer full communicating functions from the UI.

Communicating

User Interface (UI) is designed to self-program with the GZ unit when connected to the ABCD connector on the UPM board. Only two (2) wires are needed from the UI for the AB connections since the GZ unit has a transformer for the 24v (see Fig. 12 and 13).

NOTE: It is always a good idea to run extra thermostat wires during installation in the event of faulty wires, etc.

Communicating System Tips:

- The GZ units include an Outdoor Air Temperature (OAT) sensor in the literature packaging. Refer to Table 9 for thermostats that can incorporate this OAT and the thermostat instructions for wiring.
- The GZ unit must be used with Wall Control version 13 or newer software for communicating connections.
- Energy tracking is not available for the geothermal products at this time for the Wall Control V13 software. However, future UI software versions will have this feature.
- Wi-Fi capability will be available with the Wi-Fi Wall Controls SYSTXCCITC01, SYSTXCCITW01, SYSTXBBECC01, SYSTXBBECCW01.
- To enter the Wall Control service mode hold the service cap in the main menu for about 10 seconds until it turns green then release.
- The last 10 system faults can be found in the service screens. Flash codes on the UPM board flash only an active code with series of short and long flashes on the amber LED. A code 37 will appear on the UPM LED as 3 short flashes followed by a pause then 7 long flashes followed by another pause and repeats this series. The Wall Control will display text on the screen for the last 10 events.
- Exit service screens by selecting "Done".

Non-Communicating

On non-communicating system, the two-stage control receives 24VAC low-voltage control system inputs through the Y1, Y2, and O connections located at the bottom of the control board (see Fig. 14.) On a non-communicating system, output W1 is connected to the control board for auxiliary heat. For Non-communicating, any standard multi-stage HP (3 heat, 2 cool) thermostat is acceptable. Non-communicating will not have full features. Refer to Table 9 for the recommended communicating and non-communicating thermostats.

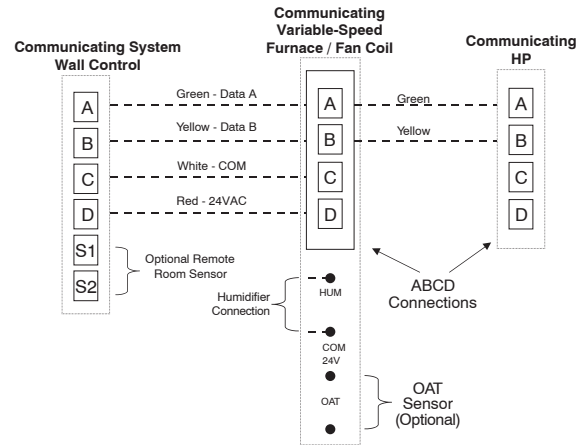

Fig. 12 - Universal Two-Wire Connection

A150168

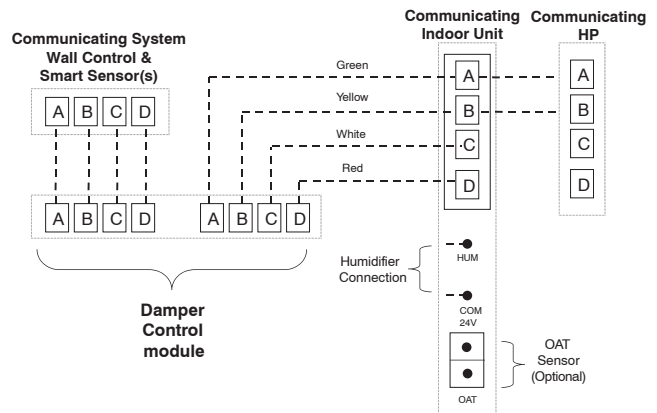

Fig. 13 - Zoning Connection for Communicating Indoor Unit with 2-Stage Communicating split geothermal unit

A150169

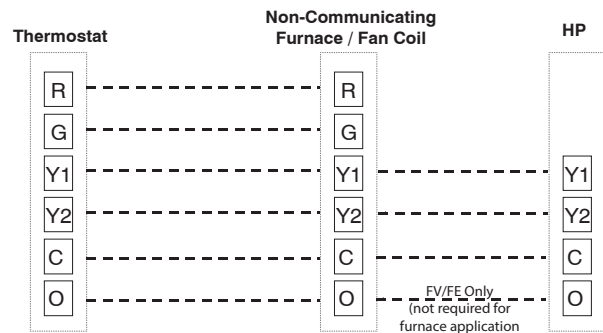

Fig. 14 - Connection for Non-comm. Furnace / Fan Coil

A150461

Table 9 – Recommended Thermostats

Carrier Systems:	Bryant Systems:
Infinity® Touch Wall Control	Evolution® Connex™ Wall Control
SYSTXCCITC01*	SYSTXBBECC01*
SYSTXCCITW01*	SYSTXBBECCW01*
SYSTXCCITN01*	SYSTXBBECCN01*
Performance™ Series	Preferred™ Series
TP-PRH01	T6-PRH
TP-NRH01	T6-NRH
TP-PHP01	T6-PHP
Cor® Wi-Fi™ Thermostat	Housewise® Wi-Fi™ Thermostat
†TP-WEM01	†T6-WEM01

* Version 13 or later software
 † No OAT sensor connection. The OAT is retrieved from the Internet. The GZ unit is shipped with one OAT sensor TSTATXXSEN01-B
Note: Any of the model numbers above may be followed by a revision letter such as "-A".

ELECTRICAL

Refer to electrical component box layout. See Fig. 15.

⚠ CAUTION

UNIT OPERATION HAZARD

Failure to follow this caution may result in equipment damage and/or improper operation.

- Field wiring must comply with local and national electrical codes.
- Power to the unit must be within the operating voltage range indicated on the unit nameplate or on the performance data sheet.
- Operation of unit on improper line voltage or with excessive phase imbalance will be hazardous to the unit, constitutes abuse, and may void the warranty.

Properly sized fuses or HACR circuit breakers must be installed for branch circuit protection. See unit nameplate for maximum fuse or breaker size.

NOTE: Use copper wire only between disconnect switch and unit.

The unit is provided with a concentric knock-out for attaching common trade sizes of conduit, route power supply wiring through this opening.

Always connect the ground lead to the grounding lug provided in the control box and power leads to the line side of compressor contactor as indicated on the wiring diagrams.

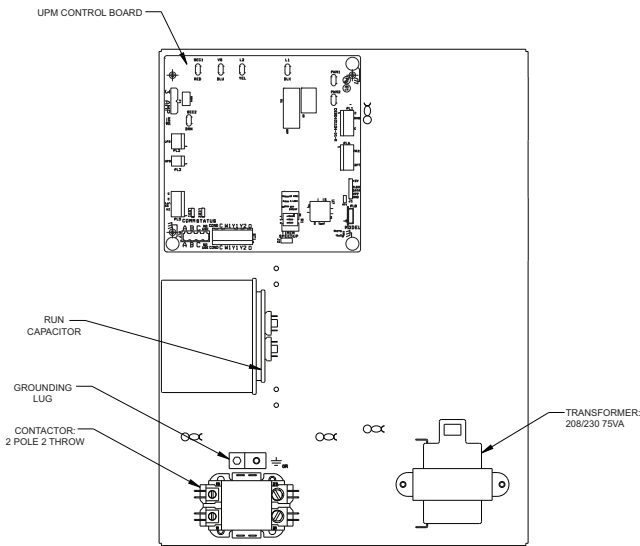

Fig. 15 - Electrical Component Box Layout

The electrical box is designed to allow servicing behind the box relatively easily to access reversing valve, etc. The 2-3 screws on the bottom of the electrical box could be removed and with wiring all out one side of the box carefully swing box in direction of the wiring bundle to allow access to components behind the box if necessary. Remember that all sides of the cabinet are accessible but in event the unit is placed where all sides make this difficult, removal of the box may help.

The transformer is a 75va transformer which should provide ample power for accessories. Size loads properly so they do not exceed capability of the transformer.

The transformer allows 208/230V selection with the factory default of 230V. The transformer has a 5amp circuit breaker internally built in for class 2 rating.

The circuit board has a 3 amp fuse that should identify any issues before the 5 amp circuit breaker trips. In an unlikely event of the transformer 5 amp circuit breaker tripping, it has a manual reset.

Utility Curtailment

Utility curtailment is a voluntary energy saving program offered through utility companies in some locations. Utility company will provide the equipment that allows them to cut back demand on equipment during peak demand times. A qualified HVAC technician should install the device to ensure system compatibility. Refer to Fig. 16 for typical wiring to the UPM.

Systems using communicating user interface controls will set up the control by entering the service screens, Setup and then select Utility Curtailment.

There will be 3 options to enable or disable the curtailment:

1. Disabled: the utility curtailment, if wired into the UPM, will be ignored.
2. *Low Stage: when utility curtailment relay opens, the unit will only operate at low-stage.
3. *Off: when utility curtailment relay opens, the unit will shut down until the utility relay closes.

* There will be a brief delay to cause the unit to stage or shut down (approximately 0.40 to 1.20 minutes can be expected).

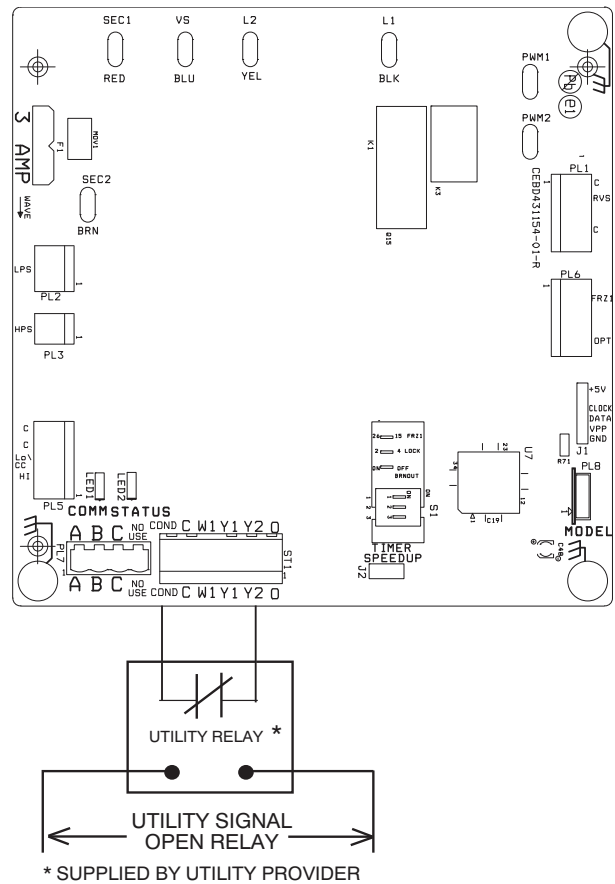
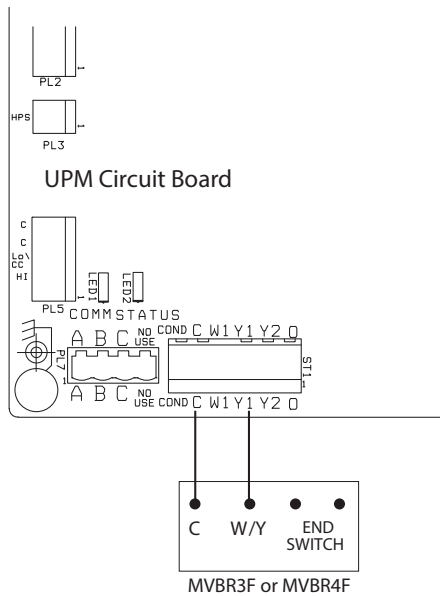

Fig. 16 - Utility Curtailment Wiring

A150166



NOTE: Optional wiring if wiring kit #4129 is not used.

Fig. 17 - Solenoid Valve Wiring

A150166

Communicating controls notes:

1. The UPM board includes a delay at terminal Y1 (connector ST1) that delays the compressor from starting after receiving a call from the thermostat to provide time for the valve to fully open. Therefore, the end switch is not used for communicating controls.
2. For systems with two valves, see Fig. 18.

IMPORTANT:
Ensure that wire colors match up when connecting harness (brown to brown, blue to blue, black to black).

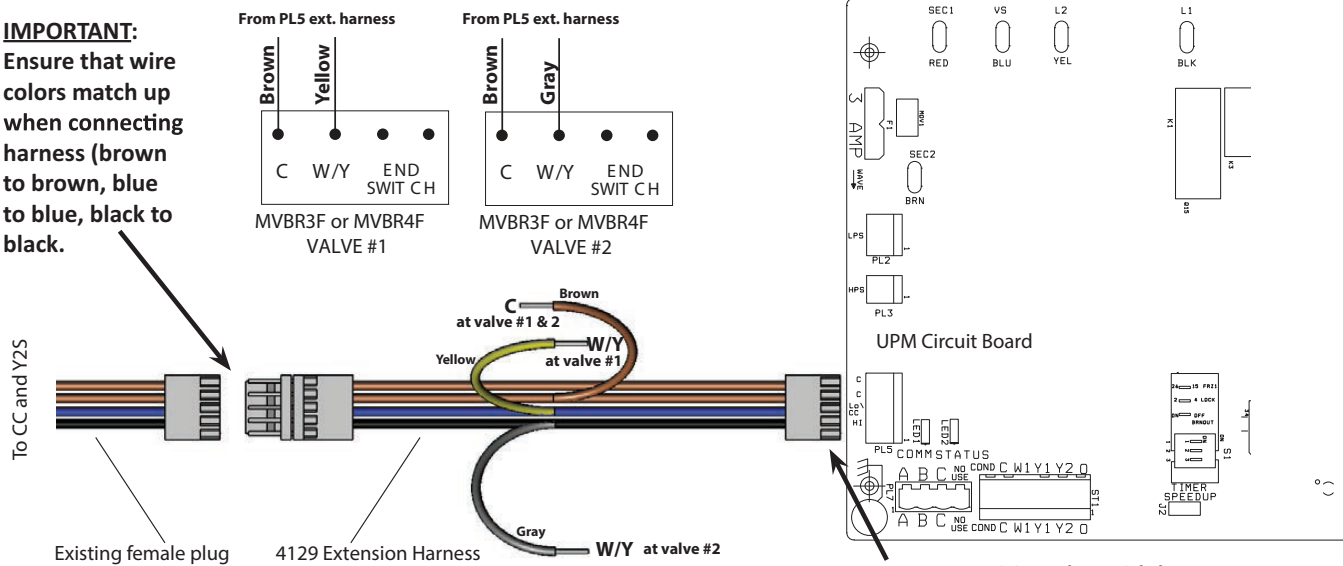

IMPORTANT: Position plug with brown wire on top and plastic plug (no wire in socket) on the bottom.

A160124

Communicating controls notes:

1. Y2 (connector ST1) is used for a utility curtailment input, and is not available for use as an output for the second valve. However, the wiring harness extension (part # 4129) used for variable speed flow centers (closed loop applications) provides a second stage connection as shown above (gray/brown wires). The wiring kit should be used for systems with two solenoid valves (yellow wire for stage 1, gray wire for stage 2, brown wire for common to both valves).
2. The UPM board delays the compressor from starting after receiving a call from the thermostat to provide time for the valve to fully open. Therefore, the end switch is not used for communicating controls.

Fig. 18 - Two Solenoid Valve Wiring

Transformer Sizing

Each MVBR3F/MVBR4F valve may use up to 11.5 VA. Verify heat pump installation manual to ensure that heat pump transformer is large enough for heat pump controls, water solenoid valve(s), and any other accessories. Other water solenoid valves

may have higher VA requirements than the MVBR3F and MVBR4F valves

FACTORY INSTALLED FEATURES

A number of factory installed options are available on the GZ Series of Heat Pumps. The following details the purpose, function and components of each option.

Heat Recovery Package (HRP) (optional)

The heat recovery package is a factory installed option on GZ series heat pumps. The HRP can be used to heat potable water during unit operation using waste heat from the compressor discharge gas. In some cases the HRP can provide most or all of the hot water requirements for a typical home.

The HRP consists of three major components:

1. Double wall, vented refrigerant to water heat exchanger
2. Circulating pump
3. Control circuit

The heat exchanger is rated for use with potable water and is acceptable for use as a domestic water heating device in most building codes.

The pump circulates water between the domestic hot water tank and HRP heat exchanger in the Heat Pump. The control circuit ensures that the HRP only operates when there is available heat from the compressor and when the water is within a safe temperature range of below 140°F. When the heat pump compressor operates, the HRP will monitor the temperature of the discharge gas from the compressor. Once discharge gas is hot enough to provide useful heat to the domestic water tank, the circulating pump will be enabled, drawing water from the tank, through the HRP heat exchanger and then depositing the heated water back into the tank.

If the water temperature reaches 140°F, the circulating pump is disabled to prevent over heating of the domestic water. The HRP is provided with an on/off switch in case the end user desires that the HRP be inactivated (typically during the winter months when space heating is most important).

The circulating pump is enabled when compressor discharge temperature reaches 120°F (48.9°C).

The circulating pump is disabled if an overload condition exists (over 1.35 amps).



CAUTION

UNIT DAMAGE AND/OR OPERATION HAZARD

Failure to follow this caution may result in unit damage and/or improper equipment operation.

If heat recovery unit is installed in an area where freezing may occur, the unit must be drained during winter months to prevent heat exchanger damage. Heat exchanger ruptures that occur due to freezing will void the heat recovery package warranty along with the heat pump warranty.



CAUTION

UNIT DAMAGE AND/OR OPERATION HAZARD

Failure to follow this caution may result in unit damage and/or improper equipment operation.

Do not apply additional controlled devices to the control circuit power supply without consulting the factory. Doing so may void equipment warranties.

FIELD INSTALLED ACCESSORIES

Liquid Line Solenoid Accessory

Experience and good design practice dictate 75 feet as the maximum practical length for interconnecting refrigerant lines in split system heat pumps without special considerations. Beyond 75 feet, system losses become substantial and the total refrigerant charge required can compromise the reliability and design life of the equipment.

Local codes or installation may suggest a liquid line solenoid, installation of long line solenoid should adhere to valve installation instructions.

Accessory Liquid Solenoid with Communicating System Wall Control: When using the Wall Control, the liquid-line solenoid output is provided at the Y1 connection. Connect the solenoid as shown in Fig. 19. This is a 24VAC output that is energized whenever the compressor is energized. In compressor OFF mode, it closes to prevent refrigerant migration into the unit through the liquid-line.

Systems with Accessory Liquid Solenoid Using a Non-Communicating Thermostat:

The liquid solenoid is connected to the Y1 and C terminal connections (see Fig. 19) and assumes that both Y2 and Y1 are energized by the thermostat during call for high stage operation.

In compressor OFF mode, the liquid solenoid closes to prevent refrigerant migration into the unit through the liquid-line. The terminal connections for Y1 and C will have LLS and the stat wires sharing the same connection points.

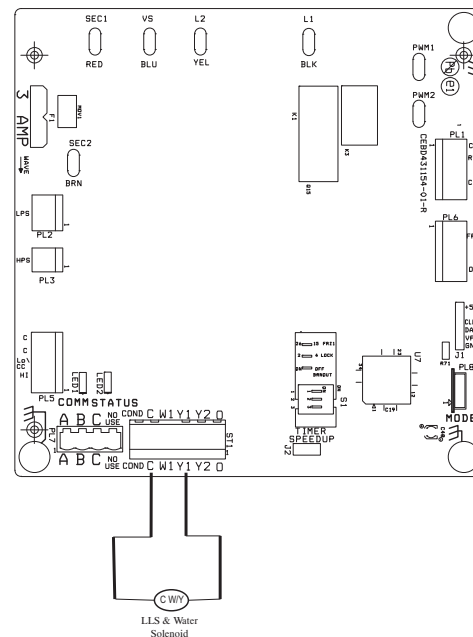

NOTE: Optional wiring if wiring kit #4129 is not used.

Fig. 19 - LLS and Water Solenoid Connections

A150167

Outdoor Air Temperature Sensor (OAT)

An optional outdoor air temperature (OAT) sensor is provided in the literature package. Install the sensor outdoors, typically on the north side of the residence away from direct sunlight. Sensor package includes an adhesive holder for the sensor. See Fig 20 for wiring the sensor to the OAT plug on the fan coil or furnace unit control board. Do not connect to the optional remote sensor terminals (S1, S2) on the UI.

Humidity control uses the OAT to adjust humidity target when the OAT drops into the cold range to prevent forming of condensation on windows. It also allows the UI to display outdoor air temperature.



A150195

Fig. 20 - OAT Sensor Connection

Compressor Start Accessories

In the event of the rare occurrence of compressor starting issues such as dimming of the residential lights. Verify and correct voltage issues and add hard start components. Table 10 lists Hard Start components that are recommended in areas of poor power conditions.

Table 10 – Recommended Hard Start Kits

Unit Size	Compressor	Hard Start Kit	Start Cap	Start MFD	Start Cap Volts	Start Relay
GZ024	ZPS20K5E –PFV	KSAHS2501AAA	HC95DE088	88 – 108	330	HN61HB540
GZ036	ZPS30K5E –PFV	KSAHS2501AAA	HC95DE088	88 – 108	330	HN61HB540
GZ048	ZPS40K5E –PFV	KSAHS2801AAA	HC95DE088	88 – 108	330	HN61HB553
GZ060	ZPS51K5E –PFV	KSAHS2801AAA	HC95DE088	88 – 108	330	HN61HB553
GZ072	ZPS60K5E –PFV	N/A	014 – 0053 – 38	43	330	HN61HB553

PRE START-UP CHECKLIST



CAUTION

UNIT DAMAGE AND/OR OPERATION HAZARD

Failure to follow this caution may result in unit damage and/or improper equipment operation.

Equipment should never be used during construction due to likelihood of wall board dust accumulation in the air coil of the equipment which permanently affects the performance and may shorten the life of the equipment.



CAUTION

UNIT DAMAGE AND/OR OPERATION HAZARD

Failure to follow this caution may result in unit damage and/or improper equipment operation.

Check with all code authorities on requirements involving condensate disposal/overflow protection criteria.

- Ensure the isolation valves are open and water control valves are wired.
- Loop/water piping is complete and flushed, (clean and purged of air).
- Verify loop water chemistry meets requirements on water chemistry table (reference table 1)
- Antifreeze is added if necessary
- Verify HRP switch is energized, if applicable. Recommend de-energize if installed and water not available.
- Verify the HRP system is purged and connected completely, if applicable.
- Verify the freeze protection is set according to proper freeze temperature (26 or 15° F)
- Remove access panels to access applicable compartments.
- Verify sufficient space is available for accessing and servicing areas such as the blower and electric heat compartment and the compressor and electrical control box compartment.
- Verify all supply voltage is in accordance with unit nameplate.
- Verify all wiring is tight and secure.
- Check that the unit blower is free to rotate and wheel is secure to shaft.
- Verify the condensate drain pan is clear and drains with proper external trap and pipe pitch.
- Ensure the system air filters are installed.
- Ensure no wiring is pinched when panels are re-installed.
- Verify loop pump wiring, if applicable, is in accordance with the pump installation instructions.
- Verify all system accessories and components are wired per applicable instructions and all wiring in accordance with NEC.
- If non-communicating thermostat ensure the UPM dip switch settings are configured accordingly for Freeze Protection, Lockout trip setting and Brownout). UPM dip switch settings can be configured in the User Interface during set up (see steps below in user interface quick setup).
- Ensure all panels are in place before powering up the unit.
- Always check incoming line voltage, power supply and secondary control voltage for adequacy. Transformer primaries are dual tapped for 208 and 230 volts. Connect the appropriate tap to ensure a minimum of 18 volts secondary control voltage. 24 volts is ideal for best operation.
- The following guidelines are recommended for wiring between a thermostat and the unit: 18 GA up to 60 ft (18.3m), 16 GA up to 100 ft. (30.5m), and 14 GA up to 140 ft. (42.7m).

UNIT START-UP

If the unit utilizes the Communicating User Interface, reference information in the User Interface Quick Setup section.

Non-communicating thermostats:

- Set the thermostat to the highest setting.
- Set the thermostat system switch to “COOL”, and the fan switch to the “AUTO” position. The reversing valve solenoid should energize. The compressor and fan should not run.
- Reduce the thermostat setting approximately 5 degrees below room temperature.
- Verify the heat of rejection is within 10% of the product data for conditions the unit is started under in cooling mode.
- Turn the thermostat system switch to the “OFF” position. The unit should stop running and the reversing valve should de-energize.
- Leave the unit off for approximately five (5) minutes to allow for system equalization.
- Turn the thermostat to the lowest setting.
- Set the thermostat switch to “HEAT”.
- Increase the thermostat setting approximately five (5) degrees above room temperature.
- Verify the unit heat of extraction is within 10% of the unit product data information when started in the heating mode of operation.
- Set the thermostat to maintain desired space temperature.
- Check for vibrations, leaks, etc.
- It is suggested that a start up / commissioning form be completed for each new installation. This document should be kept at both the job site and with the project folder of the installing contractor if needed to refer back to.

USER INTERFACE QUICK SET-UP

Install only approved thermostats per the unit Product Data. Communicating geothermal units require UI software version 13 or later. Read and Understand the thermostat Installation Instructions, this start-up is not intended to replace the thermostat Installation Instructions.

Install each component per unit Installation Instruction. Wire each accordingly.

Enter the service and installation screens in the UI

Upon powering up the system, the user interface installation will seek out the control boards in the unit and recognize the unit model and size and communicating electric heat, if installed.

Component search order:

- Indoor (ECM is the indoor if GC model)
- Outdoor (UPM)
- SAM if applicable
- Zoning if applicable
- Any non-com components via selectable screens.

Run set up to select specific features desired such as UPM switch settings (brownout, lockout and freeze protection).

UI SYSTEM INITIAL POWER UP AND CHECKOUT



WARNING

ELECTRICAL SHOCK HAZARD

Failure to follow this warning could result in personal injury or death.

Ensure cabinet and electrical box are properly grounded

- From the UI main screen select menu. Then find and select the service cap icon. Touch and hold the icon for about 10 seconds until it turns red then release to enter the screen that provides these options:
 - Equipment summary
 - Installation
 - Setup
 - Checkout
- Select Installation to initialize equipment set up and follow screen prompts as necessary.
- Verify equipment summary is correct and complete by selecting equipment summary.
- Select Setup option to select system settings such as brownout protection, lock out settings and freeze protection. Set up air flow settings in the Setup option. Follow on screen prompts for airflow options.
- Airflow verification test can be achieved from the installation and service screen after full installation.

Cooling Airflows:

- Quiet: lowest airflow (~300CFM pr ton)
- Comfort: Default (varied on temp/humidity)
- Efficiency: (1 and 2) (fixed and no dehum)
- Max: (~400 CFM pr ton) (no dehum)

Heating Airflows:

- Comfort: Default (varied on temp/humidity)
- Efficiency: (1 and 2) (fixed and no dehum)
- Max: (~400 CFM pr ton) (no dehum)

Check out mode can now be accessed to check out cooling or heating modes for up to 120 minutes and can be stopped at any time.

- Verify low cool
- Verify high cool
- Verify low heat
- Verify high heat
- Verify Electric Heat Operation in emergency and auxiliary heat mode if applicable
- Conduct System Verification per the section below and the start-up checklist.
- Set up the thermostat for normal operation, set up customer preferences for programming
- Check for vibration, leaks, etc.
- Make sure company logo and contact info has been added to UI.
- Explain thermostat operation and maintenance to the homeowner.

SYSTEM VERIFICATION

(COMMUNICATING & NON-COMMUNICATING)

- The unit is shipped with a Unit Start-up Checklist in the literature package. Allow the unit to operate for minimum of 5 minutes between system changes to stabilize before checking system performance.

NOTE: It is not recommended to access the refrigerant system at start up on package units. Access should only be necessary as last resort in troubleshooting to prevent unnecessary charge issues.

- Check the water flow and operating conditions. Reference Table 10.

NOTE: Tables typically show 3 GPM rates for each unit size. Rates are described from top to bottom listed as:

Top listed GPM: minimum suggested for open loop.

Middle listed GPM: minimum suggested for closed loop.

Bottom listed GPM: Suggested rate for closed loop.

- Verify the unit is operating within 10% of the Heat of Extraction (HE)/Heat of Rejection (HR) published in the unit Product Data Performance tables. Access Product Data on HVAC Partners.
 - a. HE/HR= GPM x TD x Fluid Factor (500 for water, 485 for antifreeze).
 - b. Utilize Ht. Abs Btu/hr in heating mode for capacity.
 - c. Utilize Ht. Rej Btu/hr in cooling mode for capacity.
- Record all data on the Startup Checklist included in the unit packet. Save the checklist in the customer file at your dealership.

Solenoid Valve Start-Up

The first time the water solenoid valve is operated, it may require 30 to 45 seconds to power open. This time is to charge an internal capacitor. After the initial "power up" the valve will open in 5 seconds. If the line voltage power has been turned off for service of the unit, the system will go through the same first time power up sequence.

The 24 VAC connections to the water solenoid valve should be made on the "C" and "W/Y" terminals. The power from the unit controls is identified as "C" and "Y1". The same terminals are used if wiring in a liquid line solenoid. (See Fig. 19)

Initial Start-Up of HRP



CAUTION

UNIT DAMAGE AND/OR OPERATION HAZARD

Failure to follow this caution may result in unit damage and/or improper equipment operation.

Make sure all valves in heat recovery water piping system are open. NEVER OPERATE HR PUMP DRY.

1. Turn on the heat pump. The HR pump should not run if the compressor is not running.
2. Turn HR switch to the "ON" position. The pump will operate if entering water temperature to HR is below 140°F and compressor discharge temperature is 120°F or above.
3. The temperature difference between the water entering and leaving the heat recovery should be 5°F to 15°F.
4. Allow the unit to operate for 20 to 30 minutes to ensure it is functioning properly. The pump should shut off when the water temperature entering the heat recovery reaches 140°F.

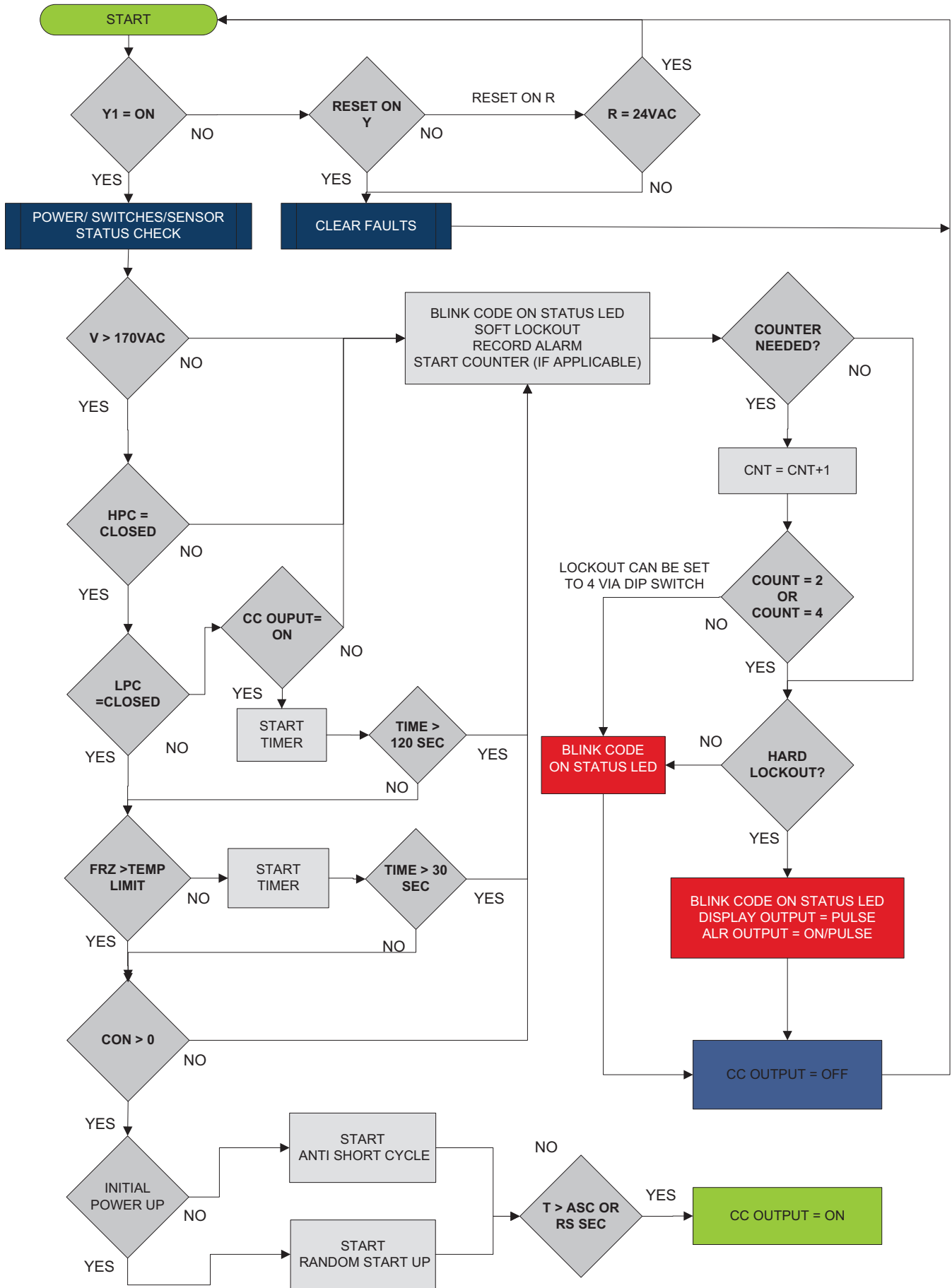

Fig. 21 - UPM Sequence of Operation (SOO) Flow Chart

A150171

SYSTEM FUNCTIONS AND SEQUENCE OF OPERATION

GZ models utilize either a Communicating Wall Control or a standard 2-stage heat pump thermostat.

With a call for first stage cooling/heating, the low stage is energized. If low-stage cannot satisfy the cooling/heating demand, high stage is energized by the second stage of indoor thermostat. After second stage is satisfied, the unit returns to low-stage operation until the first stage is satisfied or until second stage is required again.

When both first and second stage cooling are satisfied, the compressor will shut off. When a 2-stage unit is operating at low-stage, system vapor (suction) pressure will be higher than a standard single-stage system or high-stage system.

Communicating Sequence: The UPM board controls all functions. See Fig. 22.

Non-Communicating Sequence: The reversing valve is energized to cool.

Cooling - The first stage of cooling powers Y1 and O. The second stage of cooling powers Y1, Y2 and O.

Heating - The first stage of heating powers Y1, and the second stage of heating powers Y1 and Y2.

Communication and Status Function Lights

A green LED (COMM light) on the UPM (see Fig. 22) indicates successful communication with the other system products. The green LED will remain OFF until communication is established. Once a valid command is received, the green LED will turn ON continuously. If no communication is received within 2 minutes, the LED will be turned OFF until the next valid communication.

Amber Status Light - An amber colored STATUS light is used to display the operation mode and fault codes as specified in the troubleshooting section. See Table 15 for codes and definitions. **NOTE:** Only one code will be displayed on the UPM board (the most recent, with the highest priority).

Time Delays

Unit time delays include:

- Five minute time delay to start cooling or heating operation when there is a call from the thermostat or user interface. To bypass this feature, momentarily short and release Timer Speed-Up pins.
- Five minute compressor re-cycle delay on return from a brown-out condition.
- Two minute time delay to return to standby operation from last valid communication (with UI only).
- There is no delay between staging from low to high and from high to low capacity. The compressor will change from low to high and from high to low capacity "on the fly" to meet the demand.

Compressor Operation

The basic scroll design has been modified with the addition of an internal unloading mechanism that opens a by-pass port in the first compression pocket, effectively reducing the displacement of the scroll. The opening and closing of the by-pass port is controlled by an internal electrically operated solenoid.

The modulated scroll uses a single step of unloading to go from full capacity to approximately 67% capacity. A single speed, high efficiency motor continues to run while the scroll modulates between the two capacity steps. Modulation is achieved by venting a portion of the gas in the first suction pocket back to the low side of the compressor, thereby reducing the effective displacement of the compressor.

Full capacity is achieved by blocking these vents, thus increasing the displacement to 100%. A DC solenoid in the compressor controlled by a rectified 24 volt AC signal in the external solenoid plug moves the slider ring that covers and uncovers these vents.

The vent covers are arranged in such a manner that the compressor operates at approximately 67% capacity when the solenoid is not energized and 100% capacity when the solenoid is energized. The loading and unloading of the two step scroll is done "on the fly" without shutting off the motor between steps.

NOTE: 67% compressor capacity translates to approximately 75% cooling or heating capacity at the indoor coil. The compressor will always start unloaded and stay unloaded for five seconds even when the thermostat is calling for high stage capacity.

Safety Devices and UPM Board

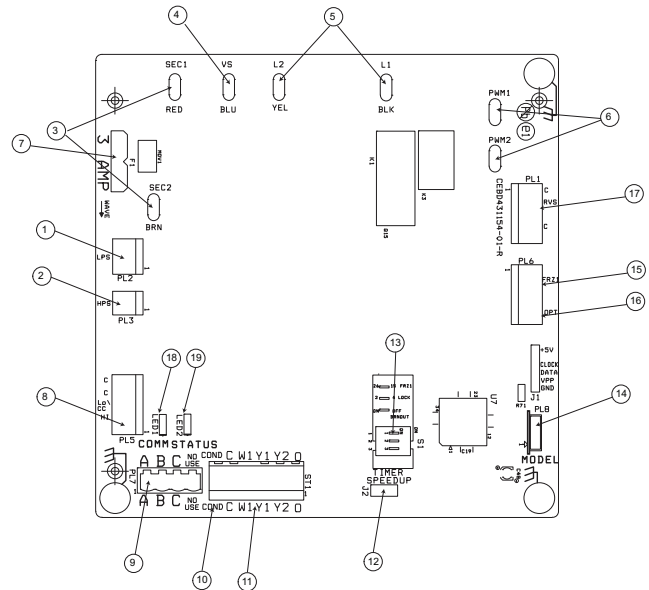

- | | |
|--|---|
| 1. PL2 LPS Low pressure switch | 11. C W 1 Y 1 Y2 O: Standard tstat connection |
| 2. PL3 HPS: High pressure switch | 12. J2 Speed Up Timer: Test jumper |
| 3. SEC1 and SEC2: Transformer | 13. S1: DIP Switches |
| 4. VS: Start circuit high volt. | 14. PL8 Model: Model plug conn. |
| 5. L2 and L1: Contactor and high voltage | 15. PL6 FRZ1: Water coil freeze sensor |
| 6. PWM1 and PWM2: N/A | 16. PL6 OPT: N/A |
| 7. F1: 3 amp fuse | 17. PL1 RVS: Reversing valve plug |
| 8. PL5: Compressor plug | 18. LED1 COMM: Comm status light |
| 9. PL7: ABCD comm. stat conn. | 19. LED2 STATUS: Status and fault code light |
| 10. COND: Condensate overflow | |

Fig. 22 - UPM Board

A150170

The UPM Board includes the following features:

- **LOW PRESSURE SWITCH:** The low pressure switch safety is designed to shut down the compressor in the event of loss of charge. Cut in 60 +/- 15 psig and cut out 40 +/- psig.
- **HIGH PRESSURE SWITCH:** The high pressure switch safety is designed to shut down the compressor if it exceeds limits. Cut in 420 +/- 15 psig and cut out 600 +/- psig.

Pressure Switch Protection: The split geothermal unit is equipped with high- and low-pressure switches. If the control senses the opening of a high- or low-pressure switch, it will respond as follows:

1. De-energize the compressor contactor.
 2. Display the appropriate fault code (see Table 15).
 3. After a 15 minute delay, if there is a call for cooling or heating and LPS or HPS is reset, the compressor contactor is energized.
 4. If the open switch closes anytime after the 15 minute delay, then resume operation with a call for cooling or heating.
 5. If LPS or HPS trips 2-4 consecutive cycles per the dip switch lockout setting or UI setting (Communicating only), the unit operation is locked out for 4 hours.
 6. In the event of a high-pressure switch trip or high-pressure lockout, check the refrigerant charge, and the coax coil (in cooling) for water issues, or indoor airflow in heating.
 7. In the event of a low-pressure switch trip or low-pressure lockout, check the refrigerant charge and indoor airflow (cooling) and coax coil water pressure and flow in heating.
- **LOW PRESSURE BYPASS TIMER:** If the compressor is running and the low pressure switch opens, the board will keep the compressor ON for 120 seconds. After 2 minutes, if the low pressure switch remains open, the board will shut down the compressor and enter a soft lockout. The compressor will not be

energized until the low pressure switch closes and the anti-short cycle time delay expires. If the low pressure switch opens 2-4 times in 1 hour, the unit will enter a 4 hour lockout period.

- **ANTI-SHORT CYCLE TIMER:** 5 minute delay on break timer to prevent compressor short cycling.
- **RANDOM START:** Each board has a unique random start delay ranging from 30 to 270 seconds on initial power up to reduce the chance of multiple unit simultaneously starting at the same time after power up or after a power interruption, thus avoiding creating large electrical spike.
- **CONTROL FAULT:** If the split geothermal unit control board has failed, the control will flash the appropriate fault code (see Table 15). The control board should be replaced.
- **UPM DIP SWITCH SETTINGS:** The UPM has 3 features controlled on the dip switch.
 1. Freeze Protection Limit for the Freeze one water coil.
 2. Lockout Settings (Soft Lockouts)
 3. Brownout (High voltage protection)

DIP SWITCH		DIP Switch Position	
		ON	OFF (Default)
SW1	Freeze Protection Limit	15°F	26° F
SW2	Number of Trips to Lockout (HPS / LPS)	4	2
SW3	Brownout	Brownout Protection is Disabled	Brownout Protection is Active

- **FREEZE SENSOR:** The water coil is protected by a thermistor located between the condensing water coil (coax) and the thermal expansion valve (see Fig. 9). The setting is default at 26°F (-3.33°C) but can be changed for units with ample anti-freeze to have a lower setting of 15°F (-9.44°C) with the dip switch selection or UI setting. If the unit is employing an open loop system (no anti-freeze protection), the freeze limit trip for the UI will only allow selection of 26°F (-3.33°C) in order to shut down the unit at the appropriate leaving water temperature and protect the heat pump from freezing. If the refrigerant temperature drops below or remains at freezing limit trip for 30 seconds, the UPM will shut down the compressor and the board will flash fault code 86 (FRZ1 lockout). Fault code 86 will remain until the condition is corrected and also requires a manual reset low voltage circuit. After a manual reset and there is a call for heating, the unit will be re-energized automatically ONLY when the freeze sensor temperature is 7°F (-13.9°C) above setpoint (SW1). Fault code 57 is FRZ1 sensor fault, which means the sensor is invalid, meaning the sensor could be open or faulty. If the sensor is invalid or out of the range (the range is from -50°F to 150°F (-45.6°C to 65.6°C), the compressor will be de-energized and display the freeze sensor fault code (57). When the sensor goes back into range, freeze sensor fault code will clear and the system will start up automatically if a demand exists.

For troubleshooting the Freeze Sensor, refer to Table 15.

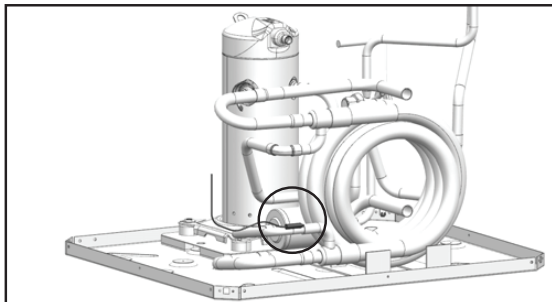

Fig. 23 - Freeze Protection Sensor Location

A14121



CAUTION

UNIT DAMAGE AND/OR OPERATION HAZARD

Failure to follow this caution may result in unit damage and/or improper equipment operation.

If unit is employing a fresh water system (no anti-freeze protection), it is extremely important to have the Freeze1 set to the default 26°F (-3.33°C).



CAUTION

UNIT DAMAGE AND/OR OPERATION HAZARD

Failure to follow this caution may result in unit damage and/or improper equipment operation.

Freeze sensor will not guard against the loss of water. A flow switch is recommended to prevent the unit from running if water flow is lost or reduced.

- **LOCKOUTS:** If system protection faults occur, the unit will shut down the compressor and fault codes will be shown on the UPM board and the UI screen. There are two types of lockouts: Soft lockouts - This is a selectable dipswitch position to allow 2 or 4 unit trips before going to hard lockout. Hard lockouts - Will require a manual reset. This applies to all unit trips unless otherwise noted. In order to exit the hard lockout early for servicing, the low voltage power to the unit would need to be reset and the fault conditions corrected. **NOTE:** The blower motor will remain active during a lockout condition.
- **BROWNOUT PROTECTION:** The compressor will be shut down if the incoming voltage falls below 170 VAC for 4 seconds and fault code will display on UPM LED and wall control (if applicable). The compressor will remain off until the voltage is above 173 VAC for at least 4 seconds and the anti-short cycle timer times out. Defeat the Brownout - The high voltage brownout feature can be defeated in the event of nuisance trips due to severe noisy power conditions. The UPM dip switch has brownout ON as default, to defeat the brown out protection, the selection can be changed to OFF. All efforts should be exhausted to correct any electrical deficiencies before defeating this safety feature to eliminate possible equipment damage.
- **COMPRESSOR VOLTAGE SENSING:** If there is no 230V at the compressor contactor(s) when the indoor unit is powered and cooling or heating demand exists, the appropriate fault code is displayed. Verify the disconnect is closed and 230V wiring is connected to the unit.
- **230V LINE (POWER DISCONNECT) DETECTION:** The control board input terminals labeled VS and L2 (see Fig. 22) are used to detect compressor voltage status and alert the user of potential problems. The control continuously monitors the high voltage on the run capacitor of the compressor motor. Voltage should be present any time the compressor contactor is energized and voltage should not be present when the contactor is de-energized.
- **CONTACTOR SHORTED DETECTION:** If there is compressor voltage sensed when there is no demand for compressor operation, the contactor may be stuck closed or there may be a wiring error. The control will flash the appropriate fault code. If the control senses the compressor voltage after start-up and is then absent for 10 consecutive seconds while cooling or heating demand exists, the thermal protector is open. The control de-energizes the compressor contactor for 15 minutes. The control Status LED will flash the appropriate code shown in Table 15. After 15 minutes, with a call for low or high stage cooling or heating, the compressor contactor is energized. If the call for cooling or heating continues, the control will energize the compressor contactor every 15 minutes. If the thermal

protector closes, (at the next 15 minute interval check) the unit will resume operation. If the thermal protector trips for three consecutive cycles, then unit operation is locked out for 4 hours and the appropriate fault code is displayed.

- **NO 230V AT COMPRESSOR CONTACTOR:** If the compressor voltage is not sensed when the compressor should be starting, the appropriate contactor may be stuck open or there is a wiring error. The control will flash the appropriate fault code. Check the contactor and control box wiring. Refer to Table 11 and Fig. 24.

Table 11 – UPM Voltage Detection

UPM Voltage Detection	Fault Code
Brownout L1 and L2	46
Compressor voltage sensing VS and L1	74
230V line power disconnect detection on L1 and L2	47
Contactor shorted detection VS and L1	73
24V transformer Sec 1 and Sec 2	No faults

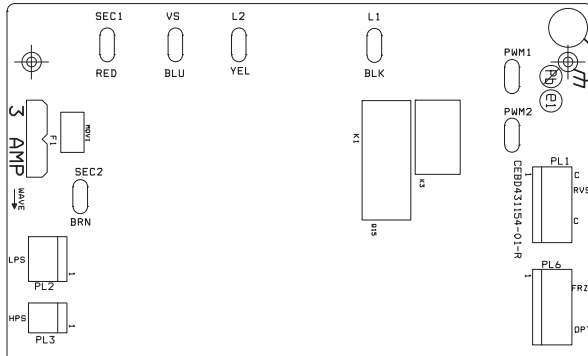

**Fig. 24 - UPM Board
L1, L2, VS, SEC 1 and SEC 2 Locations**

TIMER SPEED-UP (TEST MODE)

Timer Speed Up allows the unit to bypass all start timings to below 10 seconds to allow the unit to run for testing purposes. This speed up will last one cycle until unit shuts down for the next start.

Start timings include:

- Anti-short cycle time (5 minutes)
- Random startup

On a system with a communicating control, from the main menu, enter the Service mode by holding the Service hat icon for approximately 10 seconds until it turns green. Enter the checkout screen. This allows an option to run 5 minutes low stage or 5 minutes high stage, each adjustable up to 120 minutes and stoppable at any time.

AUXILIARY HEAT LOCKOUT

The following applies to GZ split units used with a gas furnace or fan coil with electric heat:

When using the GZ communicating units, the “Lock-out” feature for the gas furnace or electric heat is not enabled on the Infinity/Evolution wall control. The wall control is “in charge” of the comfort and the staging. Staging is not to be controlled by a one time set-up selection or by a temporary manual override. When the GHP is no longer able to satisfy the thermostat in first or second stage heating, operation will automatically switch from the GHP to the gas furnace or electric heat, which will remain in operation until the thermostat is satisfied. Although some customers want control of that changeover point based on a set outdoor air temperature, this can negatively affect the comfort and performance of the GHP.

- If the changeover temperature would be set too high, then the GHP would not be providing the customer with the best efficiency due to extended operation (run hours) of the gas furnace or electric heat resulting in higher energy costs than the customer anticipated.
- If the changeover temperature would be set too low, then the GHP would operate in conditions outside its design condition resulting in poor performance. For example, if the GHP and loop are sized to provide all the heating requirements down to 15°F prior to auxiliary heat (gas furnace or electric heat operation), then operating the GHP at outdoor temperatures lower than 15°F would result in continuous run times, reducing the loop temperature lower than its design condition. The lower loop temperature then results in lower capacity for the GHP, causing it to keep running in an attempt to satisfy the thermostat. The loop will continue to drop in temperature, causing further reduction in capacity and efficiency. This results in a negative “fly wheel” effect that is inescapable unless auxiliary heat is used or the outdoor temperature increases.
- In an open loop/well water application where the changeover temperature would be set too low and auxiliary heat was locked-out, the unit would not be able to maintain the heating set point and comfort would be compromised.
- The wall control takes the guesswork out of determining the change-over set-point and ensures that comfort and performance are not compromised.

Emerging From Set-Back

Some key operational features to consider are below:

In set-back (heating) mode:

- When coming out of set-back, the system will always first engage the GHP in first stage heat, then second stage heat, then auxiliary back-up (electric resistance or furnace).
- The system uses intelligent recovery.
- Back-up heat is not engaged until it has been determined by the control that second stage heat is not satisfying the thermostat.

If the homeowner manually bumps up the heating setpoint several degrees:

- The system will always first engage the GHP in first stage heat, then second stage heat, then auxiliary back-up (electric resistance or furnace).
- Back-up heat is not engaged until it has been determined by the control that second stage heat is not satisfying the thermostat.
- The duration of this attempt varies based on the rate of temperature rise and the difference in set-point, but is typically less than 30 minutes. The reason behind this is that the system thinks that if the homeowner increases the setpoint from, for example 70° to 74°, the extra heat is wanted now.

Table 12 – Blower Performance Data - Variable Speed Constant CFM

Models	Min Airflow (CFM)	Airflow Settings	CFM From Communicating Wall Control	
			Heating	Cooling
024 – Low	450	Max	714	714
		EFF 1	580	580
		EFF 2	625	625
		COM	532	531
		QUIET	N/A	455
024 – High	612	Max	971	971
		EFF 1	789	789
		EFF 2	850	850
		COM	724	723
		QUIET	N/A	619
036 – Low	738	Max	1171	1171
		EFF 1	952	952
		EFF 2	1025	1025
		COM	872	871
		QUIET	N/A	747
036 – High	900	Max	1429	1429
		EFF 1	1161	1161
		EFF 2	1250	1250
		COM	1064	1063
		QUIET	N/A	911
048 – Low	936	Max	1486	1486
		EFF 1	1207	1207
		EFF 2	1300	1300
		COM	1107	1105
		QUIET	N/A	947
048 – High	1080	Max	1714	1714
		EFF 1	1393	1393
		EFF 2	1500	1500
		COM	1277	1275
		QUIET	N/A	1093
060 – Low	1044	Max	1657	1657
		EFF 1	1346	1346
		EFF 2	1450	1450
		COM	1234	1233
		QUIET	N/A	1056
060 – High	1224	Max	1943	1943
		EFF 1	1579	1579
		EFF 2	1700	1700
		COM	1447	1445
		QUIET	N/A	1239
072 – Low	1152	Max	1829	1829
		EFF 1	1486	1486
		EFF 2	1600	1600
		COM	1362	1360
		QUIET	N/A	1166
072 – High	1368	Max	2171	2171
		EFF 1	1764	1764
		EFF 2	1900	1900
		COM	1617	1615
		QUIET	N/A	1384

NOTES: – CFM based on standard air conditions at 0.5" w.c. external static pressure with 2" MERV 13 filter.

Table 13 – Water Side Pressure Drop PSIG

Model	GPM	Pressure Drop (PSI)								
		30°F	40°F	50°F	60°F	70°F	80°F	90°F	100°F	110°F
GZ024	3	0.8	0.8	0.8	0.7	0.7	0.7	0.7	0.6	0.6
	4	1.4	1.3	1.3	1.3	1.2	1.2	1.1	1.0	1.0
	6	2.9	2.8	2.6	2.6	2.5	2.4	2.3	2.2	2.1
GZ036	4.5	1.6	1.5	1.4	1.3	1.3	1.2	1.2	1.2	1.1
	6	2.7	2.6	2.4	2.2	2.2	2.1	2.0	2.0	1.9
	9	5.5	5.3	4.8	4.6	4.5	4.4	4.2	4.1	4.0
GZ048	6	1.3	1.3	1.1	1.1	1.1	1.1	1.0	1.0	0.9
	8	2.2	2.1	1.9	1.8	1.8	1.7	1.7	1.6	1.6
	12	4.5	4.4	4.0	3.8	3.7	3.6	3.5	3.4	3.3
GZ060	7.5	1.4	1.3	1.2	1.2	1.1	1.1	1.1	1.0	1.0
	10	2.3	2.2	2.0	2.0	1.9	1.8	1.8	1.7	1.7
	15	4.8	4.7	4.2	4.1	3.9	3.8	3.7	3.6	3.5
GZ072	9	1.0	1.0	0.9	0.9	0.9	0.8	0.8	0.8	0.8
	12	1.7	1.7	1.5	1.5	1.4	1.4	1.3	1.3	1.3
	18	3.6	3.5	3.2	3.1	3.0	2.9	2.8	2.7	2.6

This chart shows approximate temperatures and pressures for a unit in good repair. The values shown are meant as a guide only and should not be used to estimate system charge. This chart assumes rated air flow and 80°F d.b./67°F w.b. entering air temperature in cooling, 70°F d.b. entering air temperature in heating. Heating data at entering fluid temperatures below 50°F assumes the use of antifreeze. As a result of continuing research and development, specifications are subject to change without notice.

Table 14 – Operating Temperature and Pressures

Operating Temperatures and Pressures											
			COOLING				HEATING				
Model	Entering Water Temp. °F	Water Flow	Suction Pressure PSIG	Discharge Pressure PSIG	Water Temp Rise °F	Air Temp Drop °F	Suction Pressure PSIG	Discharge Pressure PSIG	Water Temp Drop	Air Temp Rise °F	
GZ024 Part Load	30°	4					75-91	264-322	5-6	15-17	
		8					79-96	270-331	3-4	16-18	
	40°	4					88-107	277-339	6-7	17-20	
		8	115-140	175-214	8-9	19-23	92-112	284-348	4-5	18-21	
	50°	4	129-157	218-267	14-17	18-20	98-122	291-356	7-8	20-23	
		8	124-151	204-250	8-9	19-22	110-130	298-364	5-6	21-24	
	60°	4	134-163	249-305	13-16	17-20	112-136	304-372	8-10	22-26	
		8	128-156	233-287	8-9	18-21	117-143	312-381	6-7	23-28	
	70°	4	138-168	281-341	13-16	17-19	124-152	318-389	9-11	24-29	
		8	133-161	263-323	7-9	18-21	131-159	325-398	6-8	26-31	
	80°	4	143-174	317-388	13-16	16-19	136-166	331-405	11-13	27-32	
		8	137-167	297-366	7-9	17-20	143-174	339-415	7-9	28-33	
	90°	4	147-179	357-437	13-16	16-18	149-181	345-422	12-14	29-35	
		8	141-172	335-411	7-9	17-20	156-190	352-432	8-10	31-37	
	100°	4	151-185	402-492	13-15	15-18					
		8	146-177	378-459	7-9	16-19					
	GZ024 Full Load	30°	4					76-92	242-297	3-4	13-14
			8					80-97	249-304	2-3	13-15
40°		4	125-151	180-221	14-18	19-22	89-108	255-312	4-5	15-17	
		8	120-146	169-207	8-10	20-23	93-113	261-320	3-3	16-18	
50°		4	134-163	211-258	14-18	18-21	106-118	267-327	5-6	17-19	
		8	129-157	198-242	8-10	19-23	110-126	274-335	3-4	18-21	
60°		4	139-169	241-295	14-17	18-21	113-138	280-342	6-7	19-22	
		8	134-163	227-278	8-10	19-22	119-145	287-351	4-5	20-23	
70°		4	144-175	272-333	14-17	17-20	126-155	292-358	7-8	21-24	
		8	138-168	255-313	8-10	18-21	133-162	300-367	5-6	22-26	
80°		4	148-181	307-375	14-17	17-19	138-168	305-373	8-9	23-27	
		8	143-174	288-353	8-10	18-21	145-177	312-382	5-6	24-29	
90°		4	153-186	346-423	14-17	16-19	151-184	317-388	8-10	25-29	
		8	147-179	325-398	8-9	17-20	158-193	325-398	6-7	26-31	
100°		4	158-191	389-477	13-16	16-18					
		8	152-185	366-448	8-9	17-20					

This chart shows approximate temperatures and pressures for a unit in good repair. The values shown are meant as a guide only and should not be used to estimate system charge. This chart assumes rated air flow and 80° d.b./67° w.b. entering air temperature in cooling, 70° d.b. entering air temperature in heating. Heating data at entering fluid temperatures below 50° assumes the use of antifreeze. As a result of continuing research and development, specifications are subject to change without notice.

Operating Temperatures and Pressures

		COOLING					HEATING				
Model	Entering Water Temp. °F	Water Flow	Suction Pressure PSIG	Discharge Pressure PSIG	Water Temp Rise °F	Air Temp Drop °F	Suction Pressure PSIG	Discharge Pressure PSIG	Water Temp Drop	Air Temp Rise °F	
GZ036 Part Load	30°	4.5					73-89	266-325	5-6	15-18	
		9.0					77-94	272-333	3-4	16-19	
	40°	4.5	117-143	189-231	14-17	18-22	86-105	279-341	6-7	17-21	
		9.0	112-137	178-217	8-9	19-24	90-110	286-350	4-5	18-22	
	50°	4.5	126-154	221-270	14-17	18-21	105-125	293-358	7-8	20-24	
		9.0	121-148	207-253	8-9	19-23	109-130	300-366	5-6	21-25	
	60°	4.5	131-160	252-308	13-16	17-21	110-134	306-374	8-10	22-27	
		9.0	125-153	237-290	8-9	18-22	115-141	314-383	6-7	23-29	
	70°	4.5	135-165	284-347	13-16	17-20	122-150	320-391	9-11	24-30	
		9.0	130-158	266-326	7-9	18-22	129-157	327-400	6-8	26-32	
	80°	4.5	140-171	320-391	13-16	16-20	134-164	333-407	11-13	27-33	
		9.0	134-164	300-367	7-9	17-21	141-172	341-417	7-9	28-35	
	90°	4.5	144-176	360-440	13-16	16-19	147-179	347-424	12-14	29-36	
		9.0	138-169	338-414	7-9	17-21	154-188	355-434	8-10	31-38	
	100°	4.5	149-182	405-495	13-15	15-19					
		9.0	143-174	381-465	7-9	16-20					
	GZ036 Full Load	30°	4.5					74-90	244-299	3-4	13-15
			9.0					78-95	251-306	2-3	13-16
40°		4.5	122-149	183-224	14-18	19-23	87-106	257-314	4-5	15-18	
		9.0	117-143	172-210	8-10	20-24	91-111	263-322	3-3	16-19	
50°		4.5	131-160	214-261	14-18	18-22	95-105	269-329	5-6	17-20	
		9.0	126-154	201-245	8-10	19-24	100-125	276-337	3-4	18-22	
60°		4.5	136-166	244-298	14-17	18-22	111-136	282-344	6-7	19-23	
		9.0	131-160	230-281	8-10	19-23	117-143	289-353	4-5	20-24	
70°		4.5	141-172	275-336	14-17	17-21	124-152	294-360	7-8	21-25	
		9.0	135-165	258-316	8-10	18-22	131-160	302-369	5-6	22-27	
80°		4.5	145-178	310-378	14-17	17-20	136-166	307-375	8-9	23-28	
		9.0	140-171	291-356	8-10	18-22	143-175	314-384	5-6	24-30	
90°		4.5	150-183	349-426	14-17	16-20	149-182	319-390	8-10	25-30	
		9.0	144-176	328-401	8-9	17-21	156-191	327-400	6-7	26-32	
100°		4.5	155-189	392-480	13-16	16-19					
		9.0	149-182	369-451	8-9	17-21					

This chart shows approximate temperatures and pressures for a unit in good repair. The values shown are meant as a guide only and should not be used to estimate system charge. This chart assumes rated air flow and 80° d.b./67° w.b. entering air temperature in cooling, 70° d.b. entering air temperature in heating. Heating data at entering fluid temperatures below 50° assumes the use of antifreeze. As a result of continuing research and development, specifications are subject to change without notice.

Operating Temperatures and Pressures

		COOLING					HEATING				
Model	Entering Water Temp. °F	Water Flow	Suction Pressure PSIG	Discharge Pressure PSIG	Water Temp Rise °F	Air Temp Drop °F	Suction Pressure PSIG	Discharge Pressure PSIG	Water Temp Drop	Air Temp Rise °F	
GZ048 Part Load	30°	6.0					64-78	248-303	5-6	15-18	
		12.0					67-82	254-311	3-4	16-19	
	40°	6.0	109-134	183-224	18-22	19-23	75-91	261-319	6-8	17-21	
		12.0	105-128	172-210	10-12	20-25	79-96	267-327	4-5	18-23	
	50°	6.0	118-144	214-261	18-22	19-23	78-90	273-334	8-10	20-24	
		12.0	113-138	201-245	10-12	20-24	82-95	280-342	5-7	21-26	
	60°	6.0	122-149	244-298	17-21	18-22	96-117	286-349	9-11	22-27	
		12.0	117-143	230-281	10-12	19-24	101-123	293-358	6-8	24-29	
	70°	6.0	126-154	275-336	17-21	18-22	107-131	299-365	11-13	25-30	
		12.0	121-148	258-316	10-12	19-23	113-138	306-374	7-9	26-32	
	80°	6.0	130-159	310-378	17-21	17-21	117-143	311-380	12-15	27-33	
		12.0	132-153	291-356	10-12	18-22	123-151	319-390	8-10	29-35	
	90°	6.0	134-164	349-426	17-20	17-20	128-157	324-396	13-16	29-36	
		12.0	129-158	328-401	9-12	18-22	135-165	332-406	9-11	31-38	
	100°	6.0	139-170	392-480	16-20	16-20					
		12.0	133-163	369-451	9-11	17-21					
	GZ048 Full Load	30°	6.0					71-87	277-339	6-7	15-19
			12.0					75-92	284-347	4-5	16-20
40°		6.0	118-144	194-237	21-25	19-23	84-102	291-356	7-9	18-22	
		12.0	113-138	182-223	12-14	20-24	88-108	299-365	5-6	19-23	
50°		6.0	127-155	226-276	21-25	18-22	92-110	305-373	9-11	20-25	
		12.0	122-149	213-260	12-14	19-24	98-120	313-383	6-7	21-26	
60°		6.0	131-160	259-316	21-25	18-22	108-132	320-391	10-13	23-28	
		12.0	126-154	243-297	12-14	19-23	113-138	328-400	7-9	24-29	
70°		6.0	136-166	291-355	20-25	17-21	120-147	334-408	12-15	25-31	
		12.0	130-159	273-334	12-14	18-22	126-154	342-418	8-10	27-32	
80°		6.0	140-171	328-401	20-24	17-20	131-161	348-425	14-17	27-34	
		12.0	135-165	308-377	11-14	18-22	138-169	356-436	9-11	29-36	
90°		6.0	145-177	369-451	20-24	16-20	144-176	362-442	15-18	30-37	
		12.0	139-170	347-424	11-14	17-21	151-185	371-453	10-12	32-39	
100°		6.0	149-183	415-508	19-24	16-19					
		12.0	143-175	391-477	11-14	17-21					

This chart shows approximate temperatures and pressures for a unit in good repair. The values shown are meant as a guide only and should not be used to estimate system charge. This chart assumes rated air flow and 80° d.b./67° w.b. entering air temperature in cooling, 70° d.b. entering air temperature in heating. Heating data at entering fluid temperatures below 50° assumes the use of antifreeze. As a result of continuing research and development, specifications are subject to change without notice.

Operating Temperatures and Pressures

			COOLING				HEATING				
Model	Entering Water Temp. °F	Water Flow	Suction Pressure PSIG	Discharge Pressure PSIG	Water Temp Rise °F	Air Temp Drop °F	Suction Pressure PSIG	Discharge Pressure PSIG	Water Temp Drop	Air Temp Rise °F	
GZ060 Part Load	30°	7.0					68-84	256-313	5-7	19-23	
		14.0					73-89	261-319	4-5	20-25	
	40°	7.0	113-138	172-210	18-22	19-23	81-99	277-339	7-8	22-26	
		14.0	110-134	161-196	12-14	20-24	86-105	283-346	5-6	23-28	
	50°	7.0	116-142	206-252	17-21	19-23	93-114	299-365	8-9	24-29	
		14.0	112-137	193-236	12-14	19-24	99-121	305-373	6-7	25-31	
	60°	7.0	118-145	241-294	17-21	18-23	106-129	321-392	9-11	26-32	
		14.0	115-140	225-275	11-14	19-23	113-138	327-400	7-8	28-34	
	70°	7.0	121-148	275-336	17-21	18-22	118-145	342-418	10-12	29-35	
		14.0	117-143	257-314	11-14	19-23	126-154	349-427	8-9	30-37	
	80°	7.0	123-151	309-378	16-20	18-22	131-160	364-444	11-14	31-38	
		14.0	120-146	289-353	11-13	19-23	139-170	371-454	8-10	33-40	
	90°	7.0	126-154	344-420	16-20	18-22	143-175	385-471	12-15	33-41	
		14.0	122-149	321-392	11-13	18-22	152-186	393-480	9-11	35-43	
	100°	7.0	128-157	378-462	16-19	17-21					
		14.0	125-152	353-432	11-13	18-22					
	GZ060 Full Load	30°	7.0					68-84	256-313	5-7	19-23
			14.0					73-89	261-319	4-5	20-25
40°		7.0	117-143	182-222	15-19	21-26	81-99	277-339	7-8	22-26	
		14.0	114-139	170-208	11-14	22-27	86-105	283-346	5-6	23-28	
50°		7.0	120-147	215-263	15-18	20-25	93-114	299-365	8-9	24-29	
		14.0	117-143	201-246	11-14	21-26	99-121	305-373	6-7	25-31	
60°		7.0	123-150	248-304	14-17	20-24	106-129	321-392	9-11	26-32	
		14.0	119-146	232-284	11-13	21-25	113-138	327-400	7-8	28-34	
70°		7.0	126-154	282-344	14-17	19-24	118-145	342-418	10-12	29-35	
		14.0	122-149	263-322	10-13	20-25	126-154	349-427	8-9	30-37	
80°		7.0	129-157	315-385	13-16	19-23	131-160	364-444	11-14	31-38	
		14.0	125-153	294-360	10-12	19-24	139-170	371-454	8-10	33-40	
90°		7.0	132-161	348-426	13-16	18-22	143-175	385-471	12-15	33-41	
		14.0	128-156	326-398	10-12	19-23	152-186	393-480	9-11	35-43	
100°		7.0	134-164	382-466	12-15	17-21					
		14.0	131-160	357-436	9-11	18-22					

This chart shows approximate temperatures and pressures for a unit in good repair. The values shown are meant as a guide only and should not be used to estimate system charge. This chart assumes rated air flow and 80° d.b./67° w.b. entering air temperature in cooling, 70° d.b. entering air temperature in heating. Heating data at entering fluid temperatures below 50° assumes the use of antifreeze. As a result of continuing research and development, specifications are subject to change without notice.

Operating Temperatures and Pressures

		COOLING					HEATING				
Model	Entering Water Temp. °F	Water Flow	Suction Pressure PSIG	Discharge Pressure PSIG	Water Temp Rise °F	Air Temp Drop °F	Suction Pressure PSIG	Discharge Pressure PSIG	Water Temp Drop	Air Temp Rise °F	
GZ072 Part Load	30°	9.0					71-87	259-316	5-7	19-23	
		18.0					76-92	264-322	4-5	20-25	
	40°	9.0	116-141	175-213	18-22	19-23	84-102	280-342	7-8	22-26	
		18.0	113-137	164-199	12-14	20-24	89-108	286-349	5-6	23-28	
	50°	9.0	119-145	209-255	17-21	19-23	96-117	302-368	8-9	24-29	
		18.0	115-140	196-239	12-14	19-24	102-124	308-376	6-7	25-31	
	60°	9.0	121-148	244-297	17-21	18-23	109-132	324-395	9-11	26-32	
		18.0	118-143	228-278	11-14	19-23	116-141	330-403	7-8	28-34	
	70°	9.0	124-151	278-339	17-21	18-22	121-148	345-421	10-12	29-35	
		18.0	120-146	260-317	11-14	19-23	129-157	352-430	8-9	30-37	
	80°	9.0	126-154	312-381	16-20	18-22	134-163	367-447	11-14	31-38	
		18.0	123-149	292-356	11-13	19-23	142-173	374-457	8-10	33-40	
	90°	9.0	129-157	347-423	16-20	18-22	146-178	388-474	12-15	33-41	
		18.0	125-152	324-395	11-13	18-22	155-189	396-483	9-11	35-43	
	100°	9.0	131-160	381-465	16-19	17-21					
		18.0	128-155	356-435	11-13	18-22					
	GZ072 Full Load	30°	9.0					71-87	259-316	5-7	19-23
			18.0					76-92	264-322	4-5	20-25
40°		9.0	120-146	185-225	15-19	21-26	84-102	280-342	7-8	22-26	
		18.0	117-142	173-211	11-14	22-27	89-108	286-349	5-6	23-28	
50°		9.0	123-150	218-266	15-18	20-25	96-117	302-368	8-9	24-29	
		18.0	120-146	204-249	11-14	21-26	102-124	308-376	6-7	25-31	
60°		9.0	126-153	251-307	14-17	20-24	109-132	324-395	9-11	26-32	
		18.0	122-149	235-287	11-13	21-25	116-141	330-403	7-8	28-34	
70°		9.0	129-157	285-347	14-17	19-24	121-148	345-421	10-12	29-35	
		18.0	125-152	266-325	10-13	20-25	129-157	352-430	8-9	30-37	
80°		9.0	132-160	318-388	13-16	19-23	134-163	367-447	11-14	31-38	
		18.0	128-156	297-363	10-12	19-24	142-173	374-457	8-10	33-40	
90°		9.0	135-164	351-429	13-16	18-22	146-178	388-474	12-15	33-41	
		18.0	131-159	329-401	10-12	19-23	155-189	396-483	9-11	35-43	
100°		9.0	137-167	385-469	12-15	17-21					
		18.0	134-163	360-439	9-11	18-22					

This chart shows approximate temperatures and pressures for a unit in good repair. The values shown are meant as a guide only and should not be used to estimate system charge. This chart assumes rated air flow and 80° d.b./67° w.b. entering air temperature in cooling, 70° d.b. entering air temperature in heating. Heating data at entering fluid temperatures below 50° assumes the use of antifreeze. As a result of continuing research and development, specifications are subject to change without notice.

TROUBLESHOOTING

IMPORTANT: The following Troubleshooting tables are designed to help identify possible causes and solutions for problems. There could be more than one cause/solution to a problem that can be applied. Check each cause and adopt "process of elimination" and/or verification of each before making a conclusion.

Table 15 shows the status codes flashed by the amber status light. The codes are flashed by a series of short and long flashes of the status light. The short flashes indicate the first digit in the status code followed by long flashes indicating the second digit of the

error code. The short flash is 0.25 seconds on and the long flash is 1.0 seconds on. Time between flashes is 0.25 seconds. Time between short flash and first long flash is 1.0 seconds. Time between code repeating is 2.5 seconds with LED off.

Table 15 – Fault Code Table

OPERATION	FAULT	FLASH CODE	POSSIBLE CAUSE AND ACTION
Standby	18–30 VAC power is present	ON, no flash	Normal Operation
Low Stage		1, pause	Normal Operation
High Stage		2, pause	Normal Operation
Brownout Protection is Disabled		5, pause	User made selection, see instructions for details
Brownout Protection is Active		6, pause	Default, user can disable see instructions for details
	System Communication Failure	16	Communication with User Interface lost. Check wiring to and from User Interface
	Invalid Model Plug	25	Control does not detect a model plug or detects an invalid model plug. Unit will not operate without correct model plug.
	High Pressure Switch	31*	High Pressure Switch Trip. Check Refrigerant Charge, Water Flow and Temperature too high in cooling, and airflow restrictions in heating.
	Low Pressure Switch	32*	Low Pressure Switch Trip. Check Refrigerant Charge, TXV operation and airflow restrictions.
	Internal Board Failure	45	UPM board has failed. Replace Board and transfer model plug to replacement board.
	Brownout on 230V	46	Line voltage <170V for at least 4 seconds. Compressor and blower not allowed until voltage >173V. Verify line voltage. This feature can be disabled, see instructions for details.
	No 230V to unit	47	There is no 230V at the contactor when indoor unit is powered and cooling/heating demand exists. Verify the disconnect is closed and 230V wiring is connected to the unit.
	Freeze Sensor Fault	57	Freeze sensor is invalid or out of range.. Check for open sensor, wire disconnected, sensor not connected properly or abnormal sensor temp ranges.
	Compressor Thermal Cutout in Low Stage	71*	Compressor operation detected then disappears while low stage demand exist. Possible causes are internal compressor overload trip or start relay and capacitor held in circuit too long (if installed).
	Compressor Thermal Cutout in High Stage	72*	Compressor operation detected then disappears while high stage demand exist. Possible causes are internal compressor overload trip or start relay and capacitor held in circuit too long (if installed).
	Voltage at Standby (contactor shorted)	73	Compressor voltage sensed when no demand for compressor operation exists. Contactor may be stuck closed or there is a wiring error.
	No Voltage to Compressor (No voltage at startup)	74	Compressor voltage not sensed when compressor should be starting. Contactor may be stuck open or there may be a wiring error.
	Thermal Lockout in Low Stage for 4 Hours	81	Thermal cutout occurs in 3 consecutive low/high stage cycles. Low stage locked out for 4 hours or until 24V power recycled.
	Thermal Lockout in High Stage for 4 Hours	82	Thermal cutout occurs in 3 consecutive high/low stage cycles. High stage locked out for 4 hours or until 24V power recycled.
	Low Pressure Lockout	83	Low Pressure Switch (LPS) trips 2 or 4 times in an hour. Unit operation is locked out for 4 hours or until 24V power recycled.
	High Pressure Lockout	84	High Pressure Switch (HPS) trips 2 or 4 times in an hour. Unit operation is locked out for 4 hours or until 24V power recycled.
	Freeze Sensor Lockout	86	Refrigerant temperature drops below or remains at freeze limit trip for 30 seconds, the unit enters into a permanent lockout and needs a manual reset. Water coil freeze sensor below limit, verify proper loop water temp and pressures. Verify sensor accuracy using tables in instructions and verifying it is properly attached to coil. Verify antifreeze quantity if applicable and the freeze protection limit dip switch settings appropriate on the UPM board.

*Sequence: Compressor contactor is de-energized. If demand still exists, control will energize compressor contactor after 15 minute delay. If fault is cleared, unit will resume operation. If fault exists, blower shuts off, and error code continues to flash. Control will attempt re-start every 15 minutes. Cycling low voltage defeats the 15 minute delay.

TROUBLESHOOTING UNITS FOR PROPER SWITCHING BETWEEN LOW & HIGH STAGES

Check the suction pressures at the service valves. Suction pressure should be reduced by 3-10% when switching from low to high capacity.

Compressor current should increase 20 to 45% when switching from low to high stage. The compressor solenoid when energized in high stage, should measure 24VAC across pin numbers PL5-2 HI and PL5-5 C. When the compressor is operating in low stage, the 24V DC compressor solenoid coil is de-energized. When the compressor is operating in high stage, the 24V DC solenoid coil is energized.

The solenoid plug harness that is connected to the compressor has an internal rectifier that converts the 24V AC signal to 24V DC. **DO NOT INSTALL A PLUG WITHOUT AN INTERNAL RECTIFIER.**

Unloader Test Procedure

The unloader is the compressor internal mechanism, controlled by the DC solenoid, that modulates between high and low stage. If it is suspected that the unloader is not working, the following methods may be used to verify operation.

1. Operate the system and measure compressor amperage. Cycle the unloader on and off at 30 second plus intervals at the User Interface (from low to high stage and back to low stage). Wait 5 seconds after staging to high before taking a reading. The compressor amperage should go up or down at least 20 percent.
2. If the expected result is not achieved, remove the solenoid plug from the compressor and with the unit running and the User Interface or thermostat calling for high stage, test the voltage output at the plug with a DC voltmeter. The reading should be 24 volts DC.
3. If the correct DC voltage is at the control circuit molded plug, measure the compressor unloader coil resistance. The resistance should be approximately 330 or 1640 ohms depending on unloader coil supplier. If the coil resistance is infinite or is grounded, the compressor must be replaced.

Two Stage Compressor

The two stage compressor contains motor windings that provide 2-pole (3500 RPM) operation.

Compressor Internal Relief

The compressor is protected by an internal pressure relief (IPR) which relieves discharge gas into the compressor shell when differential between suction and discharge pressure exceeds 550-625 psi. The compressor is also protected by an internal overload attached to motor windings.

Compressor Control Contactor

The contactor has a 24volt coil. The electronic control board controls the operation of the contactor.

Troubleshoot Compressor

If the compressor fails to operate, Table 16 can be used to verify if there is any damage to the compressor windings causing system malfunction.

Table 16 – Winding Resistance

Compressor Ohms		
Model	Start Winding	Run Winding
GZ024	1.64	1.3
GZ036	1.52	0.88
GZ048	1.86	0.52
GZ060	1.63	0.39
GZ072	1.85	0.34

Tolerance +/- 7%. All resistance values must be measured with compressor at room temperature.

Systems Communication Failure

If communication with the compressor control is lost with the Communicating System Wall Control, the control will flash the appropriate fault code (see Table 15) to the rest of the communicating system, including the wall control and the indoor split geothermal unit.

Model Plug

Each control board contains a model plug. The model plug is used to identify the type and size of unit to the control.

The correct model plug must be installed for the system to operate properly (see Table 17).

Table 17 – Model Plug Information

Model	Model Plug Number	Pins 1-4	Pins 2-3
GZ024	HK70EZ001	5.1K	11K
GZ036	HK70EZ002	5.1K	18K
GZ048	HK70EZ003	5.1K	24K
GZ060	HK70EZ004	5.1K	33K
GZ072	HK70EZ005	5.1K	39K

On new units, the model and serial numbers are input into the board's memory at the factory. If a model plug is lost or missing at initial installation, the unit will operate according to the information input at the factory and the appropriate error code will flash temporarily.

NOTE: RCD replacement boards contain no model and serial information. If the factory control board fails, the model plug must be transferred from the original board to the replacement board for the unit to operate.

NOTE: The model plug takes priority over factory model information input at the factory. If the model plug is removed after initial power up, the unit will operate according to the last valid model plug installed, and flash the appropriate fault code temporarily.

Troubleshooting the Model Plug

If the unit is being identified incorrectly by model or size, verify the plug resistance per Table 17. If resistance value verifies the plug is good, ensure the plug is dry and condensate free.

NOTE: Dielectric grease (field supplied) can be used on model plug pins if condensate has been noted after drying the plug.

Service Tool

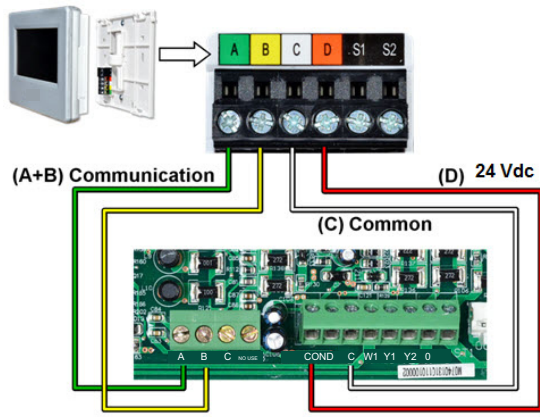

A150782

Fig. 25 - Service Tool Connection

When working on the outdoor unit of a split system, the technician would usually need to repeatedly walk between the indoor wall control and the unit outside. To save time, the communicating controls offer a service tool feature.

By wiring the service tool into the UPM board, the technician can have a wall control capable of running the system right at the outdoor unit.

To use a service tool, connect the A and B communication bus wires from this second communicating control to the terminals marked A and B on the terminal strip located in the bottom left corner of the UPM board (see Fig. 25). But instead of connecting the wires on the service tool to the terminals marked C and D, connect the C and D wires from the service tool to the 24V and C on ST1 as shown in Fig. 25.

When the service tool is connected and powered up, the communicating controls inside the home will "go to sleep" and let the service tool take control of the system. In this manner, the service technician can run the diagnostic checkouts right at the outdoor unit using the service tool.

After the checkouts are completed and it is no longer necessary to use the service tool, remove it from the communicating controls and the indoor communicating controls will regain control in about two minutes.

HRP Troubleshooting

The HR pump will be enabled when compressor discharge temperature is 120°F (48.9°C) or above.

The circulating pump will be disabled if water temperature reaches 140°F (60°C) or amperage exceeds 0.4 amps.

HRP Troubleshooting		
Problem	Possible Cause	Checks and Corrections
NO FLOW LOW FLOW	No Power	Check power supply
	On/Off Switch Position	Set switch to "ON" position
	Compressor Contactor	Engage heat pump contactor
	Broken or loose wires	Repair or tighten wires
	Air Lock	Purge air from piping system
	Stuck pump shaft/impeller	Remove pump cartridge and clean
	Defective pump	Replace pump
HIGH WATER TEMPERATURE	Water temp limit closed	Stuck limit switch
		Sensor not attached securely to line
LOW HEAT OUTPUT	Scaled or fouled heat exchanger	Clean heat exchanger

Table 18 – 10K Temperature Sensor Resistance Table

°C	°F	OHM	°C	°F	OHM	°C	°F	OHM	°C	°F	OHM
-55	-67	963,800	-9	16	52,410	37	99	6,015	83	181	1,141
-54	-65	895,300	-8	18	49,660	38	100	5,774	84	183	1,105
-53	-63	832,100	-7	19	47,070	39	102	5,545	85	185	1,071
-52	-62	776,800	-6	21	44,630	40	104	5,326	86	187	1,038
-51	-60	719,900	-5	23	42,330	41	106	5,116	87	189	1,006
-50	-58	670,200	-4	25	40,160	42	108	4,916	88	190	975
-49	-56	624,200	-3	27	38,120	43	109	4,725	89	192	945
-48	-54	581,600	-2	28	36,190	44	111	4,542	90	194	916
-47	-53	542,200	-1	30	34,370	45	113	4,368	91	196	889
-46	-51	505,800	0	32	32,650	46	115	4,201	92	198	862
-45	-49	472,000	1	34	31,030	47	117	4,041	93	199	836
-44	-47	440,700	2	36	29,500	48	118	3,888	94	201	811
-43	-45	411,600	3	37	28,050	49	120	3,742	95	203	787
-42	-44	384,700	4	39	26,690	50	122	3,602	96	205	764
-41	-42	359,700	5	41	24,400	51	124	3,468	97	207	741
-40	-40	336,500	6	43	24,170	52	126	3,339	98	208	720
-39	-38	314,900	7	45	23,020	53	127	3,216	99	210	699
-38	-36	294,900	8	46	21,920	54	129	3,099	100	212	679
-37	-35	276,200	9	48	20,890	55	131	2,986	101	214	659
-36	-33	258,800	10	50	19,900	56	133	2,878	102	216	640
-35	-31	242,700	11	52	18,970	57	135	2,774	103	217	622
-34	-29	227,600	12	54	18,090	58	136	2,674	104	219	604
-33	-27	213,600	13	55	17,260	59	138	2,579	105	221	587
-32	-26	200,500	14	57	16,470	60	140	2,488	106	223	571
-31	-24	188,300	15	59	15,710	61	142	2,400	107	225	555
-30	-22	177,000	16	61	15,000	62	144	2,316	108	226	539
-29	-20	166,400	17	63	14,330	63	145	2,235	109	228	525
-28	-18	156,400	18	64	13,380	64	147	2,157	110	230	510
-27	-17	147,200	19	66	13,070	65	149	2,083	111	232	496
-26	-15	138,500	20	68	12,490	66	151	2,011	112	234	483
-25	-13	130,400	21	70	11,940	67	153	1,942	113	235	470
-24	-11	122,800	22	72	11,420	68	154	1,876	114	237	457
-23	-9	115,800	23	73	10,920	69	156	1,813	115	239	445
-22	-8	109,100	24	75	10,450	70	158	1,752	116	241	433
-21	-6	102,900	25	77	10,000	71	160	1,693	117	243	422
-20	-4	97,080	26	79	9,573	72	162	1,637	118	244	411
-19	-2	91,620	27	81	9,166	73	163	1,583	119	246	400
-18	0	86,500	28	82	8,778	74	165	1,531	120	248	389
-17	1	81,700	29	84	8,409	75	167	1,480	121	250	379
-16	3	77,190	30	86	8,057	76	169	1,432	122	252	370
-15	5	72,960	31	88	7,722	77	171	1,386	123	253	360
-14	7	68,980	32	90	7,402	78	172	1,341	124	255	351
-13	9	65,250	33	91	7,098	79	174	1,298	125	257	342
-12	10	61,740	34	93	6,808	80	176	1,256	126	259	333
-11	12	58,440	35	95	6,531	81	178	1,216	127	261	325
-10	14	55,330	36	97	6,267	82	180	1,178	128	262	317

MAINTENANCE

- An annual “checkup” is recommended by a qualified refrigeration mechanic.
- Recording the performance measurements of volts, amps, and water temperature differences (both heating and cooling) is recommended. This data should be compared to the information on the unit’s data plate and the data taken at the original startup of the equipment.
- Periodic lockouts are commonly caused by water flow problems. The lockout (shutdown) of the unit is a normal protective measure in the design of the equipment. If continual lockouts occur, call a mechanic immediately and have them check for the following:
 - Water flow problems
 - Water temperature problems

Unit capacity and water flow charts should be used for system checks. Refer to Table 14.