

Model Specific Instructions

Split-System
Heat Pump

HA1C, HB1C
HC1C

NOTE: Read the entire instruction manual before starting the installation. Refer to Split-System Heat Pump Common Installation and Start-Up Practices (included in this packet).

SAFETY CONSIDERATIONS

Improper installation, adjustment, alteration, service, maintenance, or use can cause explosion, fire, electrical shock, or other conditions which may cause death, personal injury, or property damage. Consult a qualified installer, service agency, or your distributor or branch for information or assistance. The qualified installer or agency must use factory-authorized kits or accessories when modifying this product. Refer to the individual instructions packaged with the kits or accessories when installing.

Follow all safety codes. Wear safety glasses, protective clothing, and work gloves. Use quenching cloth for brazing operations. Have fire extinguisher available. Read these instructions thoroughly and follow all warnings or cautions included in literature and attached to the unit. Consult local building codes and National Electrical Code (NEC) for special requirements.

Recognize safety information. This is the safety-alert symbol . When you see this symbol on the unit and in instructions or manuals, be alert to the potential for personal injury.

Understand the signal word DANGER, WARNING, or CAUTION. These words are used with the safety-alert symbol. DANGER identifies the most serious hazards which **will** result in severe personal injury or death. WARNING signifies hazards which **could** result in personal injury or death. CAUTION is used to identify unsafe practices which **would** result in minor personal injury or product and property damage.

 **WARNING:** Before installing, modifying, or servicing system, main electrical disconnect switch must be in the OFF position. There may be more than 1 disconnect switch. Lock out and tag switch with a suitable warning label. Electrical shock can cause personal injury or death.

INSTALLATION

PROCEDURE 1—MOUNT UNIT TO PAD

Refer to Fig. 1 for pad dimensions and dimensions needed to mount unit to pad.

PROCEDURE 2—REFRIGERANT TUBING

Refer to Fig. 2 for refrigerant tube dimensions and connections.

NOTE: A thermostatic expansion valve (TXV) is required on all HC1C units. Step 3 refers to the installation of the TXV.

PROCEDURE 3—REMOVE INDOOR REFRIGERANT FLOW-CONTROL DEVICE AND INSTALL TXV.

 **CAUTION:** For proper unit operation and reliability, units must be installed with a field-supplied hard shutoff TXV. Do not install with evaporator coils having capillary tube metering devices or piston.

After removing existing refrigerant flow-control device from indoor coil, install field-supplied bi-flow hard shutoff TXV kit. (See Fig. 3 and 4.) For TXV kit part No. and charging instruction, refer to TXV label in your unit. If the indoor unit (fan coil) comes factory equipped with a bi-flow hard shutoff TXV, no TXV change is required.

Install TXV kit to indoor coil as follows:

1. Install suction tube adapter.
2. Install liquid flare-to-sweat adapter.
3. Connect external equalizer tube to fitting on suction tube adapter.
4. Position sensing bulb on horizontal portion of suction tube adapter. Secure using supplied hardware.
5. Insulate bulb after installation. (See Fig. 4.)
6. Leak check all connections.

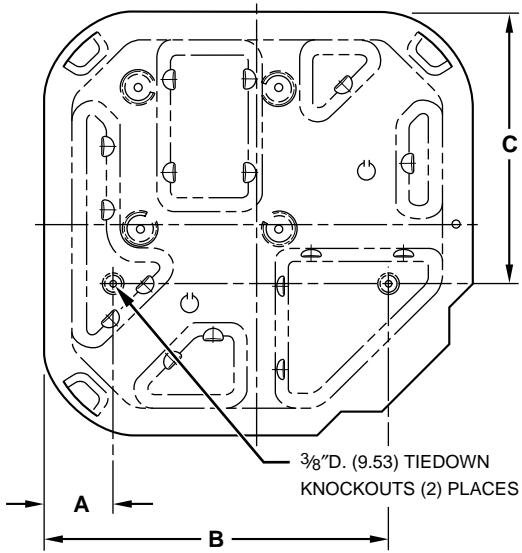

A94199

UNIT SIZE	MIN. PAD DIM. (IN.)	TIEDOWN KNOCKOUT LOCATIONS		
		A (In.)	B (In.)	C (In.)
HA1C018-030 HB1C018 HC1C018	22-1/2 X 22-1/2	3-11/16	18-1/8	14-3/8
HA1C036-060 HB1C024-060 HC1C024-060	30 X 30	6-1/2	23-1/2	20

Fig. 1—Mount Unit to Pad

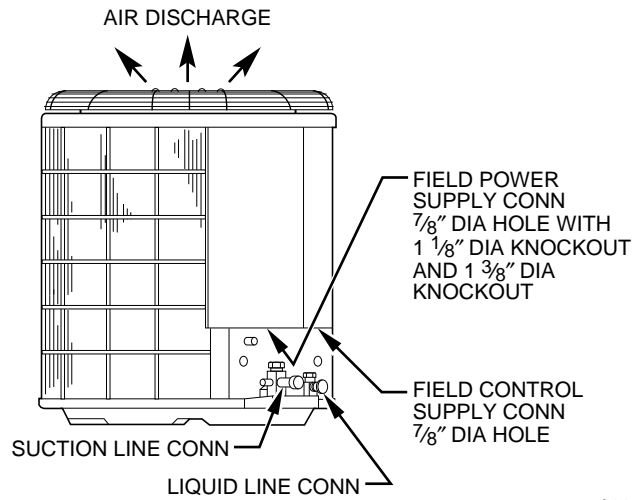

A93578

UNIT SIZE	LIQUID TUBE		VAPOR TUBE	
	Conn Dia	Tube Dia	Conn Dia	Tube Dia
018, 024	3/8	3/8	5/8	5/8
030, 036	3/8	3/8	3/4	3/4
042, 048	3/8	3/8	7/8	7/8
060	3/8	3/8	7/8	1-1/8

Tube diameters are for lengths up to 50 ft. For tubing lengths greater than 50 ft, consult your local distributor.

Fig. 2—Refrigerant Tube Dimensions/Connections

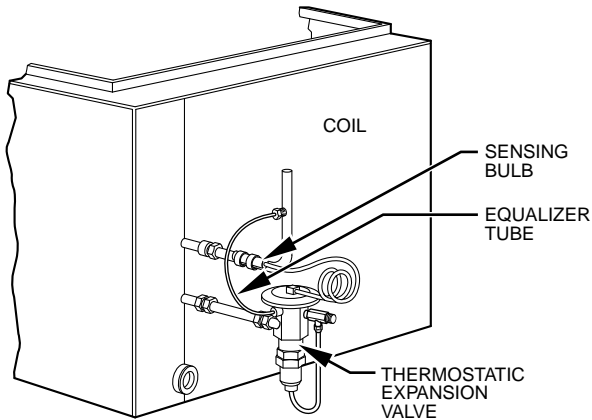

A88382

Fig. 3—Typical TXV Installation

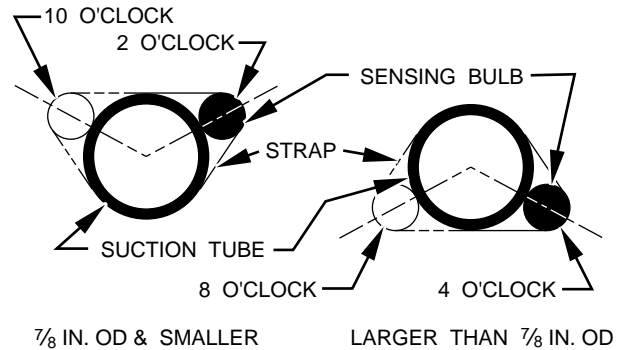

A81032

Fig. 4—Position of Sensing Bulb