

# Installation Instructions

Heat Recovery  
Ventilator

VA3A/VB5A  
VC5A

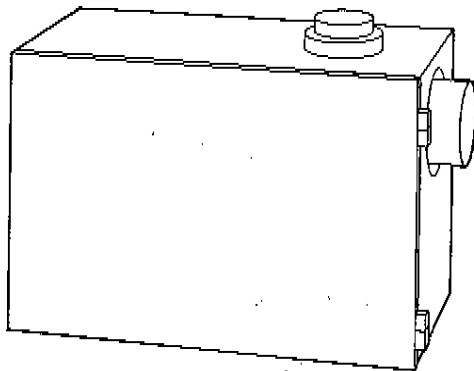

A92376

Fig. 1—VA3A Conventional Unit

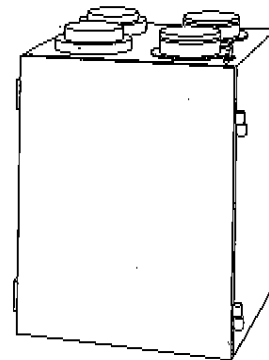

A92266

Fig. 2—VB5A Compact Unit

**NOTE:** Read the entire instruction manual before starting the installation.

## SAFETY CONSIDERATIONS

Installing and servicing heating equipment can be hazardous due to gas and electrical components. Only trained and qualified personnel should install, repair, or service heating equipment.

Untrained personnel can perform basic maintenance functions such as cleaning and replacing air filters. All other operations must be performed by trained service personnel. When working on heating equipment, observe precautions in the literature, tags, and labels attached to or shipped with the unit and other safety precautions that may apply.

Follow all safety codes. In the United States, follow all safety codes including the National Fuel Gas Code NFPA No. 54-1988/ANSI Z223.1-1988. In Canada, refer to the current edition of the National Standard of Canada CAN/CGA-B149.1- and .2-M91 Natural Gas and Propane Gas Installation Codes. Wear safety glasses and work gloves. Have fire extinguisher available during start-up and adjustment procedures and service calls.

Recognize safety information. This is the safety-alert symbol  $\triangle$ . When you see this symbol on the furnace and in instructions or manuals, be alert to the potential for personal injury.

Understand the signal word DANGER, WARNING, or CAUTION. These words are used with the safety-alert symbol. DANGER identifies the most serious hazards which will result in severe personal injury or death. WARNING signifies a hazard that could result in personal injury or death. CAUTION is used to identify unsafe practices which would result in minor personal injury or product and property damage.

## INTRODUCTION

The Heat Recovery Ventilator (HRV) is used to create an air exchange of indoor stale air with outside fresh air. These units are equipped with a heat recovery core which recovers heat that is contained in the stale air before it is exhausted, transferring it to the fresh air drawn from the exterior in winter.

Use this instruction to install Heat Recovery Ventilator (HRV) systems VA3A, VB5A, and VC5A. Units have varying capacity for air exchange as noted in product data. Select the proper unit to fit air quality requirements. (See Fig. 1, Fig. 2, and Fig. 3.)

## INSPECT EQUIPMENT

Move carton to final installation location. Remove HRV from carton taking care not to damage unit. Inspect unit for damage. File claim with shipping company if shipment is damaged or incomplete. Check to be sure unit matches job specifications. (See Fig. 4, Fig. 5, and Fig. 6.)

## AIRFLOW DIAGRAMS

The direction of the airflow is indicated in each of the following diagrams. Note the stale air never mixes with the fresh air. (See Fig. 7 through Fig. 14.)

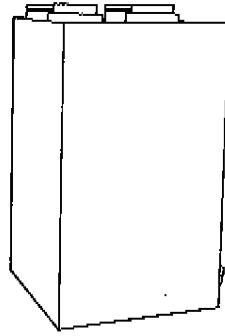

Fig. 3—VC5A High Efficiency Unit

A92377

**PROCEDURE 1—FRESH AIR DISTRIBUTION****A. Forced-Air System**

When the HRV is installed in conjunction with a new or existing forced-air system, the furnace blower and network of ducts are used to distribute the fresh air inside the building. To accomplish this, the furnace blower must operate continuously whenever the HRV is energized.

The fresh air from the HRV is introduced into the furnace return duct at a point no less than 6 ft (2 m) upstream of the furnace. This connection should be direct.

**B. Independent System**

In the absence of forced-air ductwork, the HRV requires an independent network of ducts for distribution of fresh air. Registers are normally located in the bedrooms, dining room, living room, and basement.

To ensure occupant comfort, it is recommended that register be placed 6 to 12 in. from the ceiling with airflow directed toward the ceiling. If registers are floor installed, airflow must be directed toward the wall.

**PROCEDURE 2—SELECT LOCATION**

The HRV should be located in a heated area of the house, such as the basement. It should be easily accessible for routine maintenance and should be located in close proximity to a drain and power source.

**PROCEDURE 3—SUSPEND THE UNIT**

The HRV unit must be installed level. It is recommended that the HRV be suspended from floor joists or rafters using chains and 4 springs. Attach metal hanging bracket to all 4 sides of cabinet. (See Fig. 19.)

The unit may be installed on a shelf if a rubber bumper is provided to dampen vibration. An area under the HRV must be provided to allow for drainage.

**PROCEDURE 4—LOCATE STALE AIR INTAKE FOR SYSTEMS INDEPENDENTLY DUCTED****A. Location**

Stale air is drawn from the kitchen, bathroom, basement or from other rooms where contaminants are produced. Registers must be placed 6 to 12 in. from the ceiling and 6 ft from the oven if on an interior kitchen wall.

**B. Airflow**

Proper type and size of registers must be used to minimize decreases in pressure. The velocity of the air flowing through the register should not be above 400 ft/minute (2 m/sec).

**C. Maximum Length of Duct**

The ducting system should be designed according to the highest speed of the unit. Refer to the specifications listed in the product data sheets for the ventilation capacities.

**PROCEDURE 5—CONNECT DUCTS AND CONDENSATE DRAIN TO THE HRV****A. Ducts**

Insulated flexible ducts are required on both the fresh air inlet and the exhaust air outlet ducts connecting to the exterior. These ports are identified by their double flange collars. If using insulated flexible duct, the vapor barrier of the flexible ducts must be taped very tightly.

The 36-in. section of flexible duct supplied with the unit should be cut in half and connected to both the stale air port and the fresh air distribution port. This is to eliminate the transmission of vibrations from the unit to the main ducts. (See Fig. 20.)

Four 30-in. duct ties are provided to fasten flexible duct to ports of the HRV.

**B. Condensate Drain**

To connect condensate drain, insert sleeved grommet into bottom of the unit. Insert drain tube into sleeved grommet. It is preferred to glue the drain tubing and grommet together with contact cement. A wire tie may also be used to fasten the vinyl tubing onto the sleeved grommet.

Make a loop in the tubing to create a trap to prevent sewer gases from entering the ventilation system. (See Fig. 21.) Connect the unit's drain to the building's main drain. Provide slight slope for run-off.

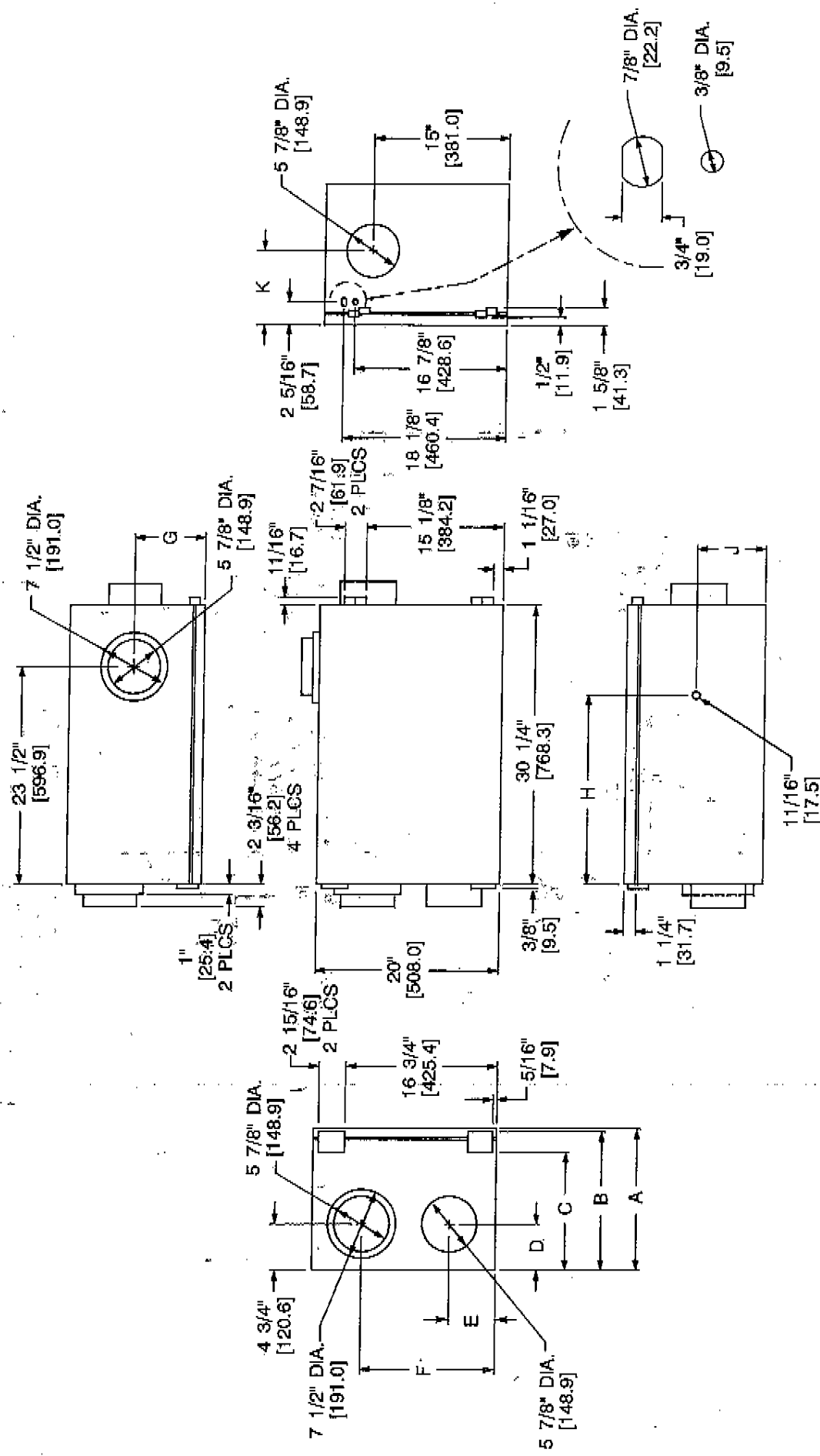

A92274

MODEL NO.	A		B		C		D		E		F		G		H		J		K	
	in.	mm	in.	mm	in.	mm	in.	mm	in.	mm	in.	mm	in.	mm	in.	mm	in.	mm	in.	mm
VA3A A015, B015	15-3/16	385.8	14-3/4	374.6	12-7/8	327.0	4-3/4	120.6	5-1/8	130.2	14-3/4	374.6	7-5/8	193.6	20-3/8	517.5	7-5/16	185.7	7-3/4	196.8
VA3A A020, B020	18-7/8	479.4	18-5/8	473.1	16-5/16	414.3	13-1/2	342.9	5-7/8	149.2	14	355.6	10	254.0	15-13/16	401.6	9-5/16	236.6	8-13/16	223.8

Fig. 4—Dimensional Drawing VA3A

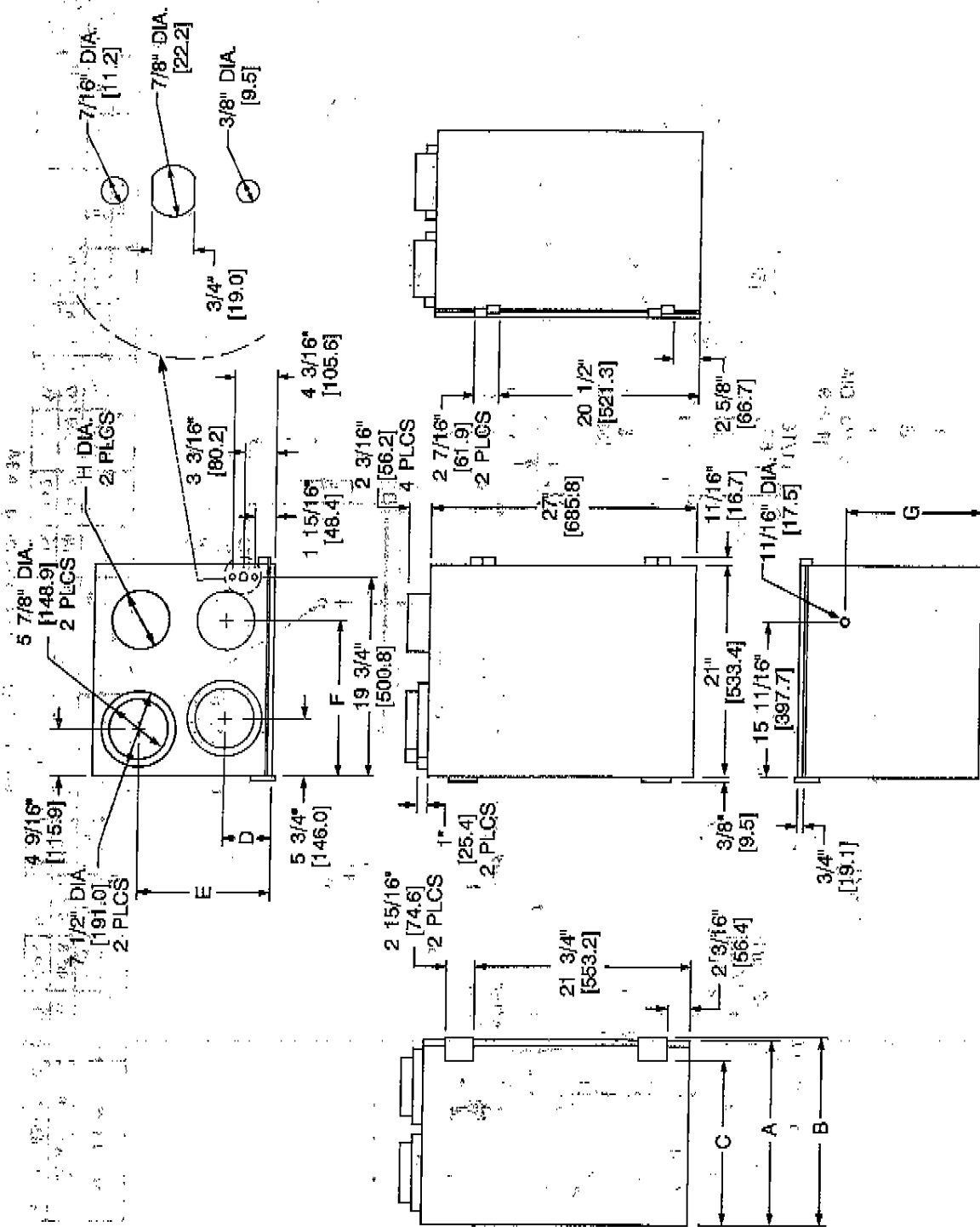

A92275

MODEL NO.	A		B		C		D		E		F		G		H	
	in.	mm	in.	mm	in.	mm	in.	mm	in.	mm	in.	mm	in.	mm	in.	mm
VB5A A015, B015	18-3/8	466.7	18-3/8	466.7	16-9/16	420.7	4-11/16	119.1	13-5/16	388.2	15-7/16	392.1	13-9/16	344.5	5-11/16	144.5
VB5A A020, B020	24-1/4	615.9	24-1/2	622.2	22-3/16	563.5	8-3/16	208.0	19-5/16	490.6	14-9/16	369.2	16-15/16	429.4	6-15/16	176.2
VC5A A015, B015																

Fig. 5—Dimensional Drawing VB5A, VC5A-A015, B015

A92276

Fig. 6—Dimensional Drawing VC5A-A020, B020, A027, B027

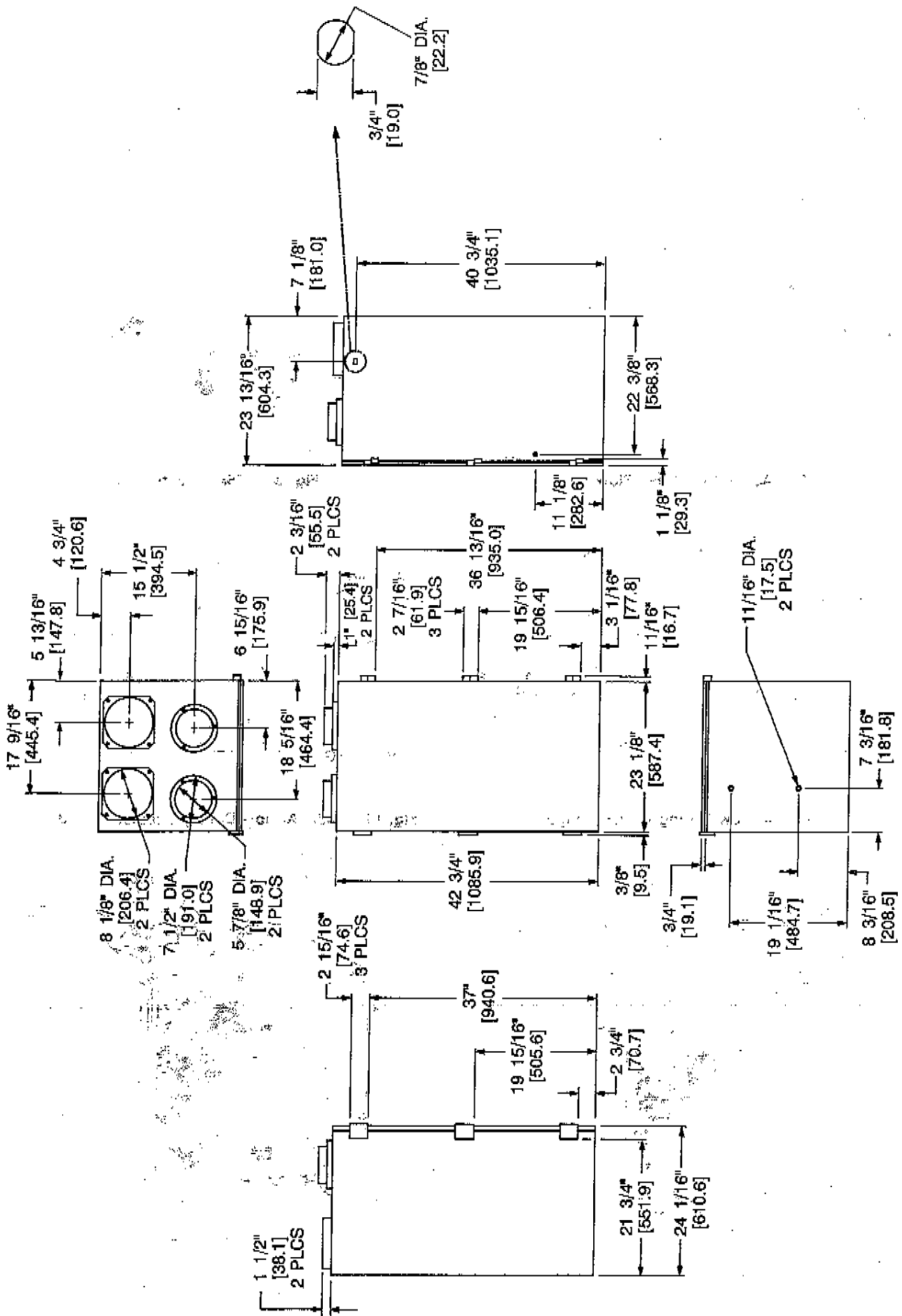

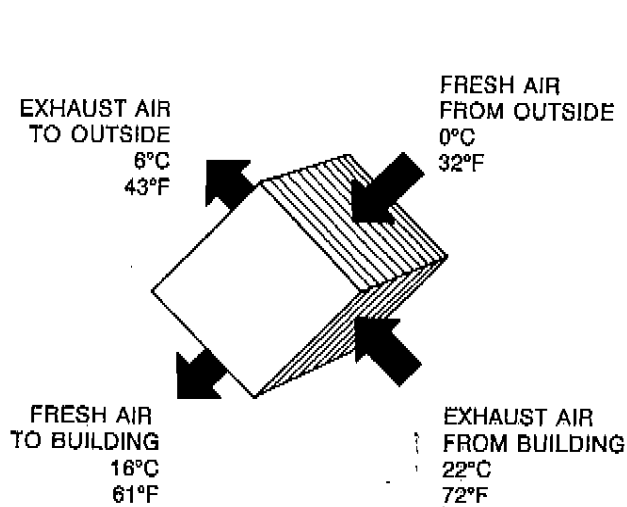

Fig. 7—VA3A/VB5A Cross-Flow

A92378

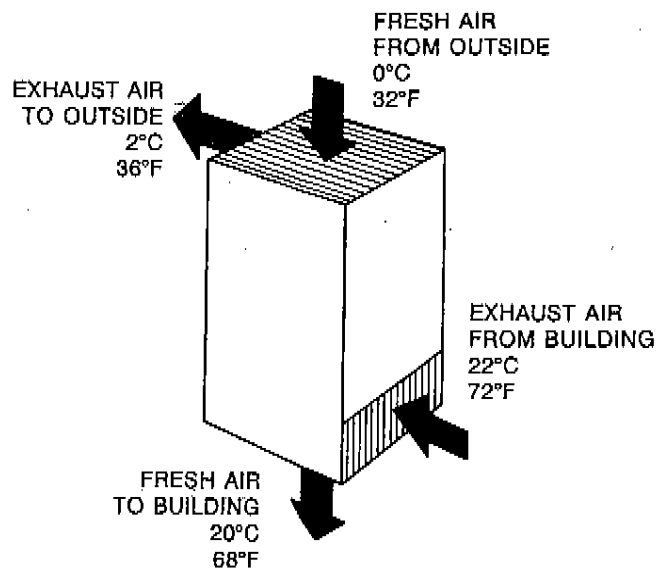

Fig. 8—VC5A Counter-Flow

A92379

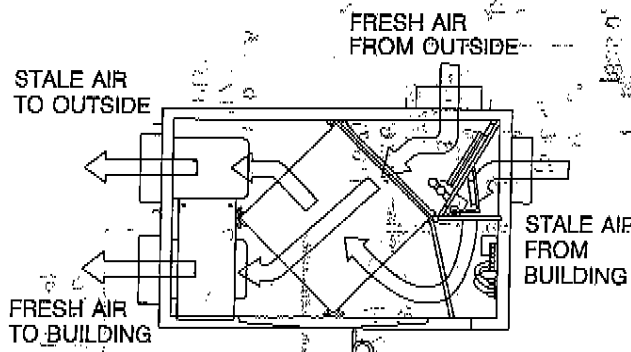

Fig. 9—VA3A Airflow During Air Exchange

A92380

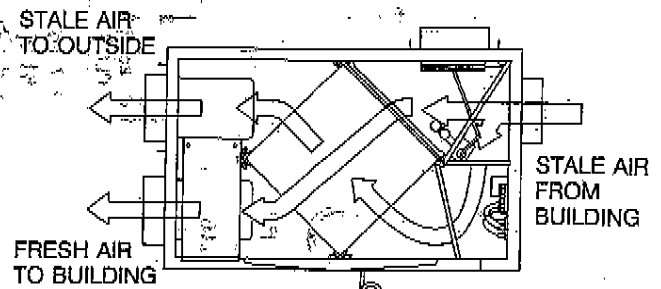

Fig. 10—VA3A Airflow During Circulation and Defrost

A92381

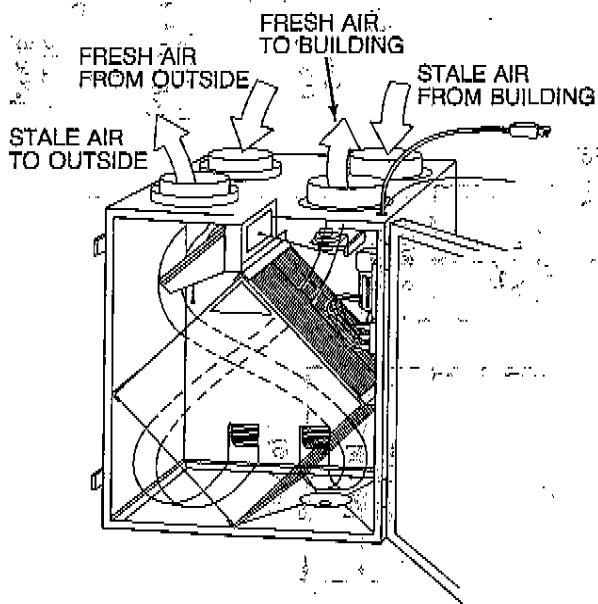

Fig. 11—VB5A Airflow During Air Exchange

A92382

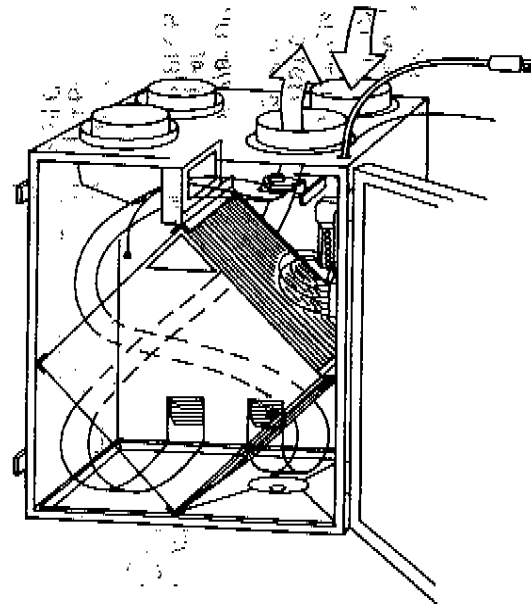

Fig. 12—VB5A Airflow During Circulation and Defrost

A92383

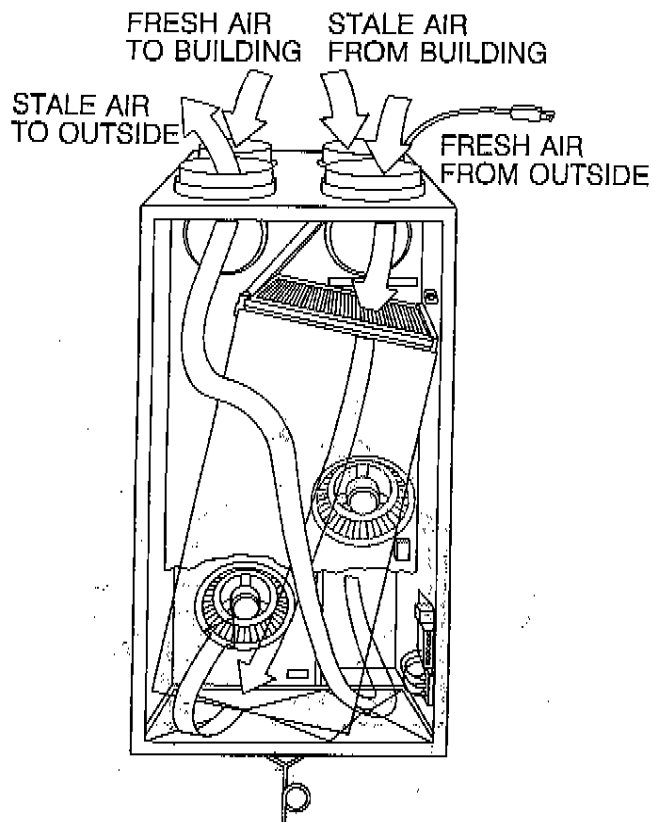

Fig. 13—VC5A Airflow During Air Exchange

A92384

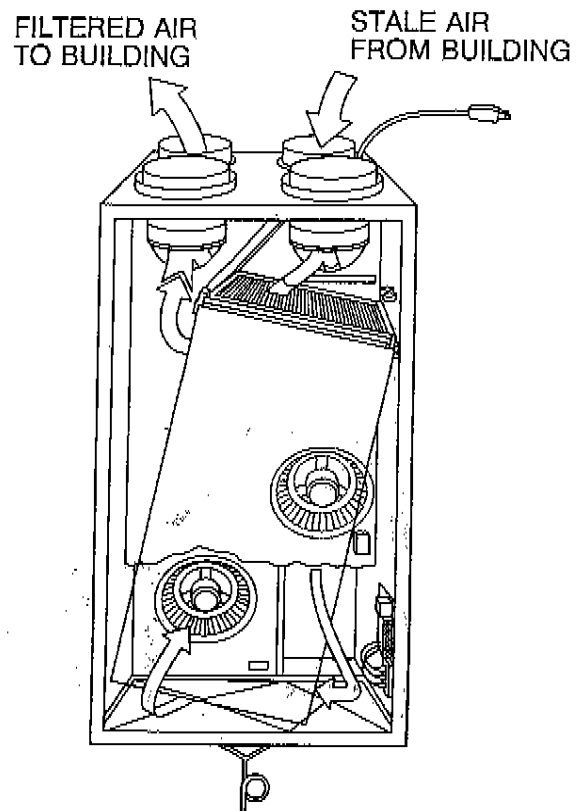

Fig. 14—VC5A Airflow During Circulation and Defrost

A92385

## PROCEDURE 6—COMPONENT DESCRIPTION

The following lists components of HRV units VA3A, VB5A, and VC5A. (See Fig. 15 through 18.)

1. Stale air port is connected to the return-air supply.
2. Fresh air port connects to outdoor air-inlet hood.
3. Exhaust port connects to outdoor exhaust hood.
4. Dampers are used to control air exchange with outside air and used during defrost mode.
5. Mechanical filter traps dust contained in the air.
6. Heat recovery core is a cross-flow type for compact models and is a counter-flow type for high-efficiency models. It transfers the heat between the 2 airstreams.
7. Blowers bring in fresh air from the outside and exhaust stale air to the outside.
8. Capacitor required for motor operations.
9. Condensation tray collects condensate from heat recovery core.
10. Drainage tube connects to sleeved grommet.
11. Defrost timer is necessary for complete defrosting of heat recovery core.
12. Electronic control circuit insures proper operation of unit.
13. Ionizer is available on automatic models and is used to neutralize fine dust particles. It cannot be used with a forced-air system incorporating an electronic air cleaner.
14. Distribution port distributes fresh air into the house.
15. Control connector allows connections with control wiring.
16. Electrical cord connects to standard 120v outlet.

## PROCEDURE 7—LOCATE AND INSTALL EXTERIOR HOODS

### A. Location

The fresh air intake and the stale air exhaust must be separated by at least 6 ft (2 m). The fresh air intake must be positioned at least 10 ft (3 m) from the nearest dryer vent, furnace exhaust, driveway, gas meter, or oil fill pipe. The fresh air intake must be positioned as far as possible from garbage containers and potential chemical fumes. When possible, it is advised to locate the intake and exhaust on opposite walls of the building or around a corner from each other. The exhaust and supply hoods should never be located on interior corners or in dead air pockets. (See Fig. 22.) Both intake and exhaust hoods must be 18 in. from the ground and at least 12 in. above the anticipated snow level.

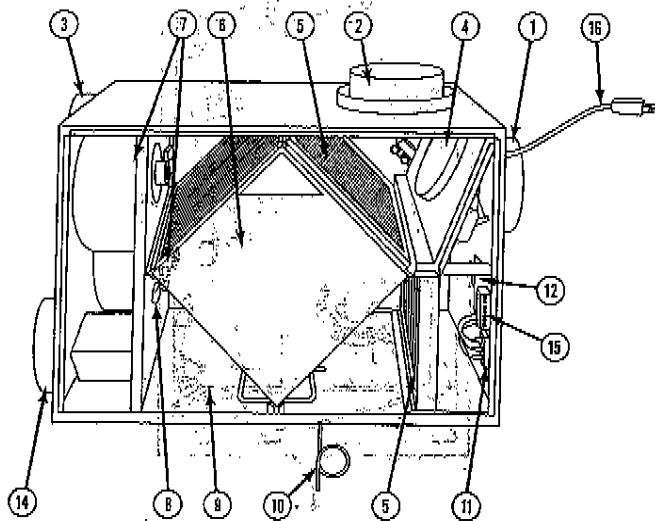

A92387

Fig. 15—VA3A Conventional Unit with 2 PSC Motors

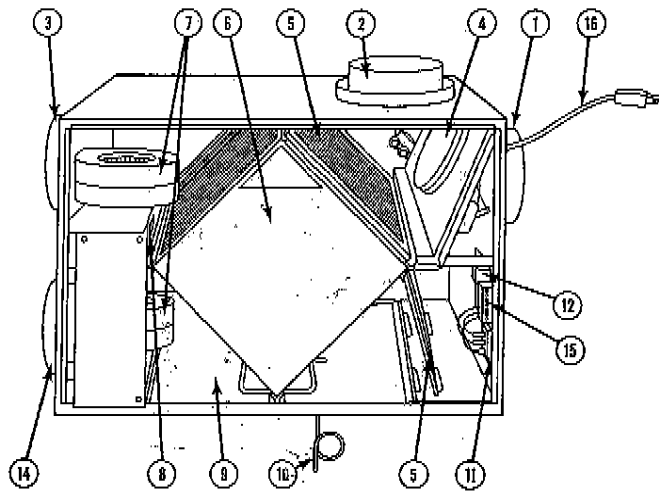

A92388

Fig. 16—VA3A Conventional Unit with 1 PSC Motor

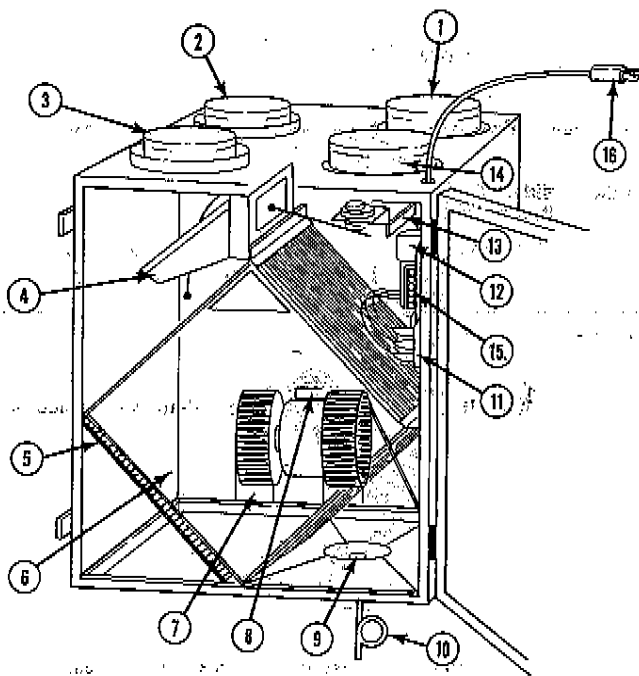

A92389

Fig. 17—VB5A Compact Unit

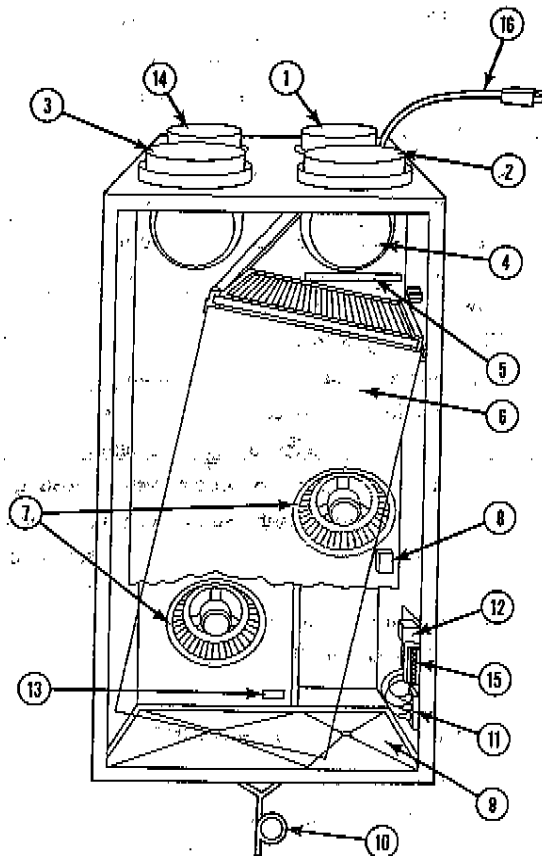

A92390

Fig. 18—VC5A Compact High-Efficiency Unit



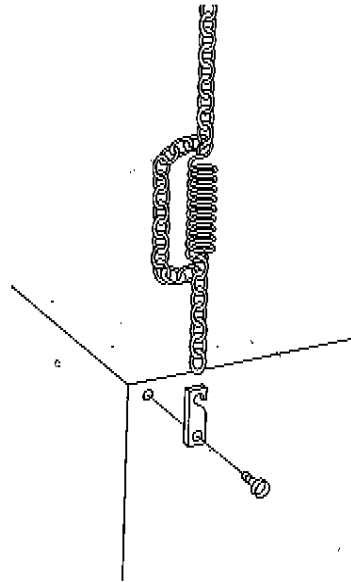

Fig. 19—Chain Spring Installation

A92269

Both the intake and exhaust hoods must be supplied with a rodent screen. Wire mesh of 1/4 in. (6mm) is recommended. Smaller mesh screens must be easily removed for cleaning. The free area of the exterior hoods must be equivalent to the connecting diameter of the HRV.

#### B. Installation

Insulated flexible duct is required for both inlet and outlet outside connections to the HRV. After making the appropriate sized wall penetration, pass the flexible duct through the penetration and insert the hood tube into the duct. Tape the duct vapor barrier tightly around the hood tube and insert the assembly back into the wall penetration and fasten securely.

#### PROCEDURE 8—INSTALL WALL CONTROLS

**NOTE:** When using a forced-air system in conjunction with an HRV, a slave relay must be used to ensure a continuous blower-interlocked operation.

#### A. Location

Install the wall control on ground floor of building. Locate as close as possible to the main thermostat, or within the flow of circulated fresh air. Position wall control approximately 60 in. (1.5 m) above floor.

#### B. Wall Control and Wiring

Connect wire to the wall control following the color code. Attach wall control to wall. (See Fig. 23.) Following the color code, connect wire to the unit by passing it through the hole located on top or right side of unit. (See Fig. 24.)

Determine type of control to be used - basic, standard, or auto. The standard and auto models come with similar functions and consist of a knob and slide switches.

#### BASIC CONTROL

To start or stop unit, slide switch to ON or OFF position. This function is the same for all 3 controls. (See Table 1.)

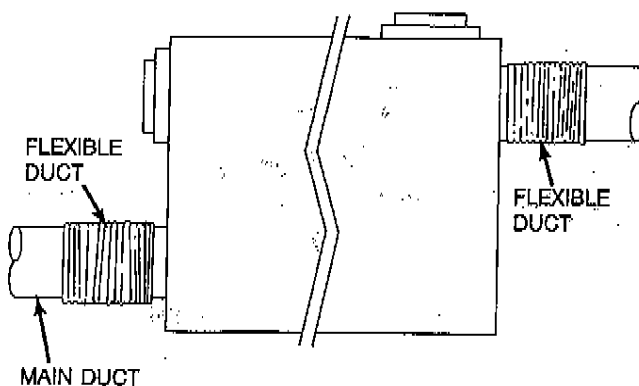

Fig. 20—Flexible Duct Fit-up

A92270

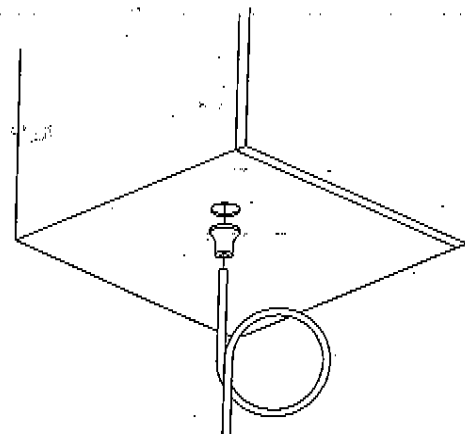

Fig. 21—Loop Trap

A92392

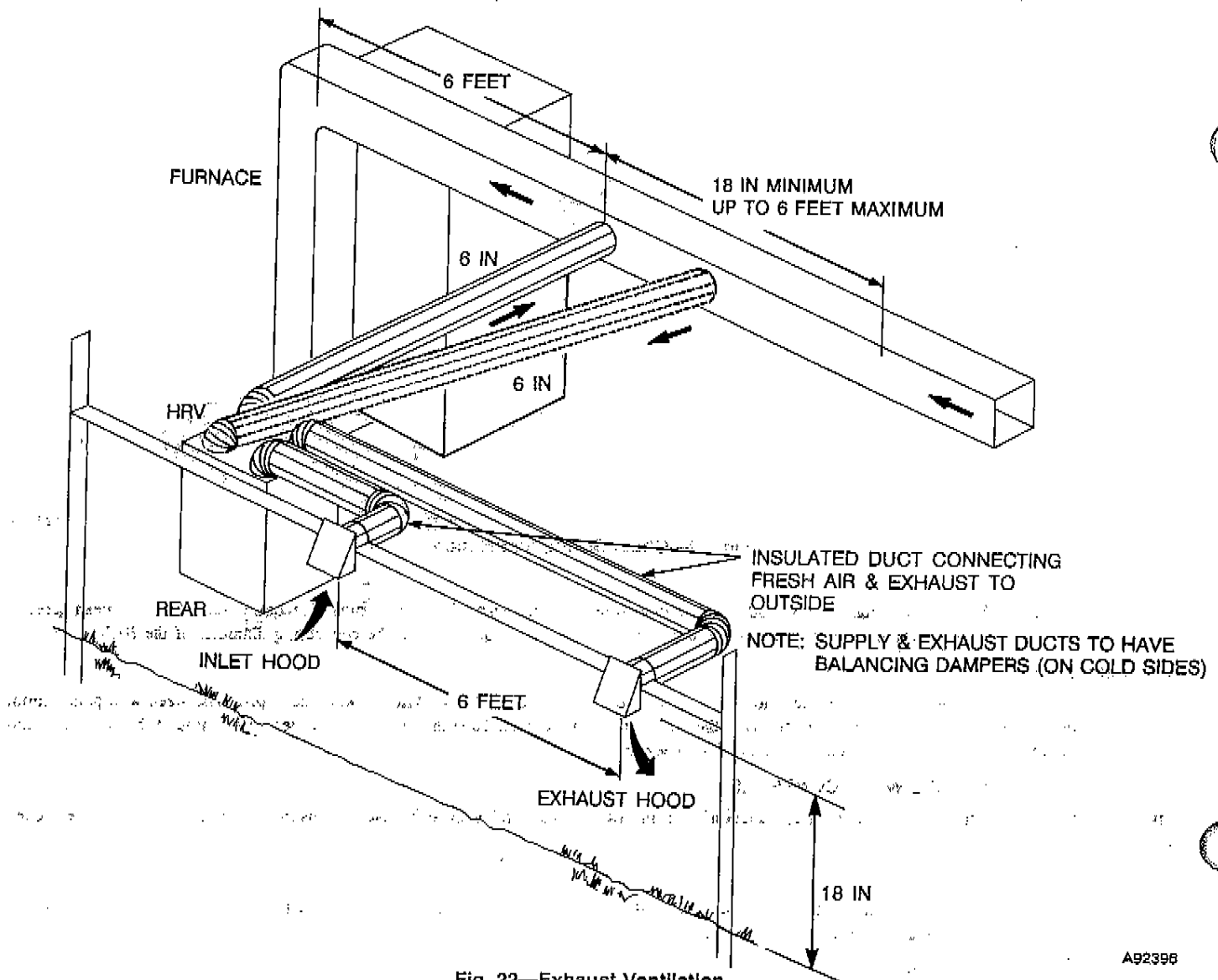

Fig. 22—Exhaust Ventilation

A92396

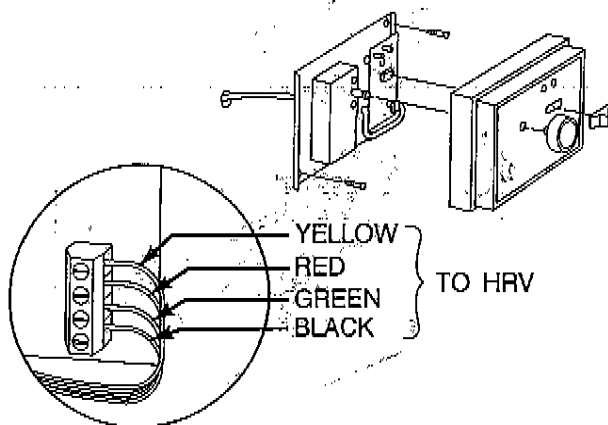

Fig. 23—Typical Wall Control

A92272

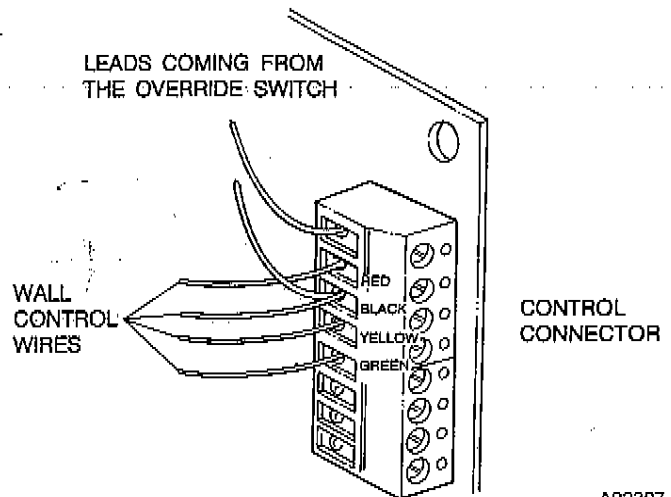

Fig. 24—Control Connector

A92397

Table 1—Basic Controls

MODE	TYPE OF OPERATION	FAN SPEED
Off	Off (Dampers close-off to outside)	Off
Low	Air Exchange With Outside	Low
High	Air Exchange With Outside	High

### STANDARD CONTROL

There are 2 operating modes available. (See Table 2.) The slide switch allows selection of the following:

1. The continuous exchange mode has 2 operating speeds. In this case, the unit will continually exchange air with the outside at low speed, and at high speed when there is an excess of humidity.
2. The intermittent exchange mode operates in low speed. The unit exchanges air with the outside at low speed and stops when it has reached the desired level of humidity. This mode is ideal for maintaining the proper level of humidity when no one is home.

### AUTOMATIC CONTROL

There are 3 operating modes available using the same slide switch. This control has the same functions as the Standard Control with the addition of a circulation mode. (See Table 3)

The circulation mode is only available on the Auto Control operating at high speed continuously. When the level of humidity is too high, the unit exchanges air with the outside. When the level of humidity is not too high, it circulates indoor air.

**NOTE:** This control is designed to be used with systems that are independent of a forced-air system. An example would be when baseboard or hot water heating systems are used.

### PROCEDURE 9—CHECK CONTROLS' OPERATING MODES

Be sure that all modes of operation are fully functional.

### PROCEDURE 10—HUMIDITY SELECTOR

The Humidity Selector is a built-in dehumidistat designed to properly control the level of humidity in the house during the winter months. This control helps avoid condensation problems in upper-northern regions where indoor humidity is a problem during the winter season.

**NOTE:** This control is not to be confused with a dehumidistat used during the summer months to control high relative indoor humidity.

Table 4 lists recommended humidity levels to avoid condensation.

### PROCEDURE 11—ACCESSORIES

#### A. Push Button Timers

The wall control electronically responds to outside temperature. At 23° F (-5° C) the unit will initiate a defrost cycle by closing off the outside air damper and recirculating heated indoor air through heat recovery core. This happens approximately every 30 minutes with a 5 minute defrost cycle. In this fashion, the core is defrosted without the use of electric strip heat. At -22° F (-30° C) the unit will sense a need for defrost every 20 minutes with a 5 minute cycle.

Push button timer kit (20-minute) can be used to override wall control. Kit number KVATM010120M includes a small control and 3 push button switches.

Also available is a 60-minute timer kit KVATM010160M. To override wall control, connect 2 wires from timer directly to red and black on HRV control connector. (See Fig. 25.)

Fasten control to the unit or wall and connect the leads to HRV control connector. (See Fig. 25.) Connect push button switches in parallel. Connect power supply to 120-v junction box.

#### B. Interlock Relay

The HRV is independently controlled. An interlock relay must be added when combining the HRV with a forced-air furnace or fan coil. When the HRV is energized, the interlock relay is also energized, bringing on both R and G inside the furnace or fan coil. This allows continuous blower operation circulating both fresh air and return air throughout the ducted system. (See Fig. 26.)

### PROCEDURE 12—BOARD CONFIGURATIONS

When determining what type of control to be used, check the jumper configuration of the control board to ensure proper operation. (See Fig. 27.)

### PROCEDURE 13—FLOW COLLAR POSITION

The arrow on the flow collar is always oriented with the airflow.

#### A. Temporary Flow Collars

**NOTE:** Flexible connectors should be located suitably to measure airflow. Always try to locate flow measuring collars in the straightest sections of duct to ensure accuracy. (See Fig. 28 or Fig. 29.) When using the temporary method, a flow collar is mounted in stale air duct of the HRV, and the airflow recorded. The flow collar is then relocated to the fresh-air duct, and airflow is recorded again. Dampers can then be adjusted to equalize airflow. The procedure should be repeated to ensure the unit is balanced properly.

Table 2—Standard Controls

MODE	TYPE OF OPERATION	FAN SPEED	DEHUMIDISTAT POSITION
Intermittent	Off (Dampers close-off to outside)	Off	At 80 percent
Exchange	Air Exchange With Outside	High	At 20 percent
Continuous	Air Exchange With Outside	Low	At 80 percent
Exchange	Air Exchange With Outside	High	At 20 percent

Table 3—Automatic Controls

MODE	TYPE OF OPERATION	FAN SPEED	DEHUMIDISTAT POSITION
Circulation	Circulation (Dampers close-off to outside)	High	At 80 percent
Exchange	Air Exchange With Outside	High	At 20 percent
Continuous	Air Exchange With Outside	Low	At 80 percent
Exchange	Air Exchange With Outside	High	At 20 percent
Intermittent	Off (Dampers close-off to outside)	Off	At 80 percent
Exchange	Air Exchange With Outside	Low	At 20 percent

Table 4—Recommended Humidity Levels

OUTSIDE TEMPERATURE		DOUBLE-PANE WINDOWS	TRIPLE-PANE WINDOWS
50° F	10° C	55 percent	65 percent
32° F	0° C	45 percent	55 percent
14° F	-10° C	35 percent	45 percent
-4° F	-20° C	30 percent	45 percent
-22° F	-30° C	25 percent	35 percent

If the level of humidity falls too low in the winter months while operating in the continuous exchange mode, a humidifier may be integrated into the system. Intermittent exchange mode may also be selected for short periods of time to increase the level of humidity.

**PROCEDURE 14—BALANCE THE SYSTEM**

Balancing is very important to proper operation of a HRV. If supply air from outside is greater than exhaust air from the house, the imbalance can result in the core of the HRV freezing up. If exhaust air from the house is greater than the supply air from the outside, combustion appliances may backdraft, bringing exhaust fumes into the house. A balanced condition will ensure optimum performance, provide satisfied customers, and avoid expensive callbacks. Installation of the balancing dampers in insulated ducts is strongly recommended.

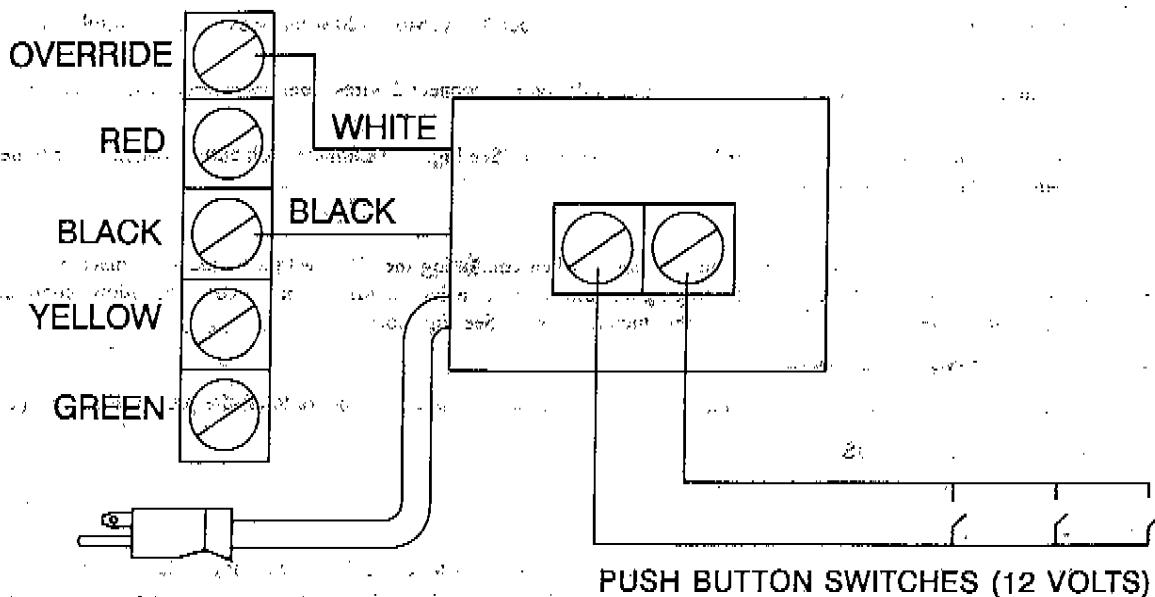

Fig. 25—Push Button Timer Wiring Layout

A92399

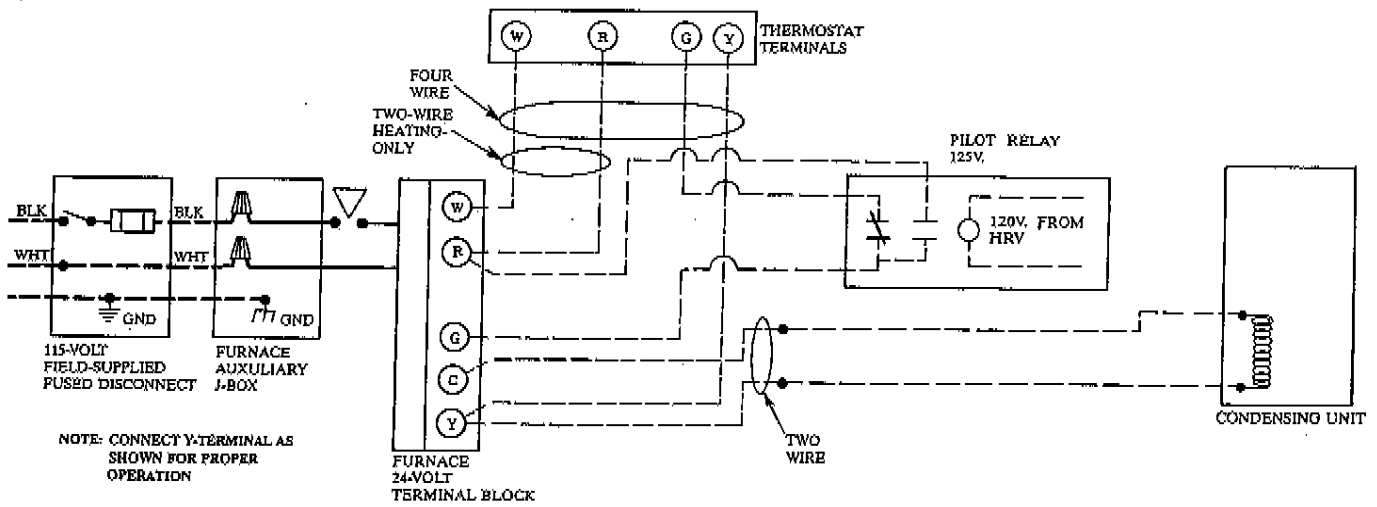

Fig. 26—Interlock Relay Wiring Layout

A92402

1. Before proceeding with balancing, all windows, doors, and fireplace flues should be tightly closed. No exhaust systems such as range top exhausts, dryer exhaust, fume hoods, bath or roof fans should be in operation. The forced-air furnace, if used for circulation, should be operating at its continuous operating speed. Ensure that the balancing dampers are fully open.
2. With the speed control at maximum speed and continuous air exchange with the outside occurring, connect the hoses from the flow collar to a magnehelic gage. (See Fig. 30.) The gage must be leveled and zeroed before use to read accurately. If the needle falls below zero, reverse the hose connections.
3. Measure the exhaust air first as it is often the lowest pressure due to a longer ductwork system. Next, measure the fresh air. If the fresh air reading is higher than the exhaust reading, adjust the damper until the reading is the same. If the reading is lower, return the grid to the exhaust damper to obtain the same reading.

**CAUTION:** Do not use HRV during the construction of a house or when sanding drywall. This type of dust may damage the system.

**PROCEDURE 15—VENTILATION EVALUATION**

Two methods used to evaluate the ventilation needs of a house are:

1. The sum of rooms x 10 cfm (5 l/s) per room, plus 20 cfm (10 l/s) for a master bedroom or basement.
2. Air exchange at 0.3 per hr x the volume of the house.

The ventilation capacity of the HRV unit while at maximum speed is defined according to the greatest total. These methods are derived from the National Building Code 1990 version and the CSA F326.1 revision.

In the illustration, there are 11 noted rooms, a master bedroom and a basement. (See Fig. 31.) Using method 1 to calculate approximate ventilation:

1.  $(11 \times 10 \text{ cfm}) + (2 \times 20 \text{ cfm}) = 150 \text{ cfm}$

Referring to the same illustration and using method 2 to calculate approximate ventilation:

1.  $1320 \text{ sq ft} \times 8 \text{ ft in height} = 10560 \text{ cu ft per floor}$
2.  $10560 \text{ cu ft} \times 3 \text{ floors} = 31680 \text{ cu ft in house}$
3.  $31680 \text{ cu ft} \times 0.3 \text{ air change per hour} = 9500 \text{ cu ft}$
4.  $9500 \text{ cu ft} \div 60 \text{ min per hour} = 160 \text{ cfm}$

The greatest total is 160 cfm, a capacity within the range of a VCSA A020 size unit.

**BASIC, STANDARD      AUTO**

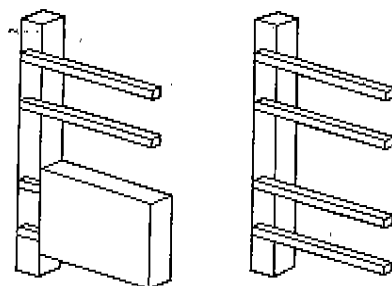
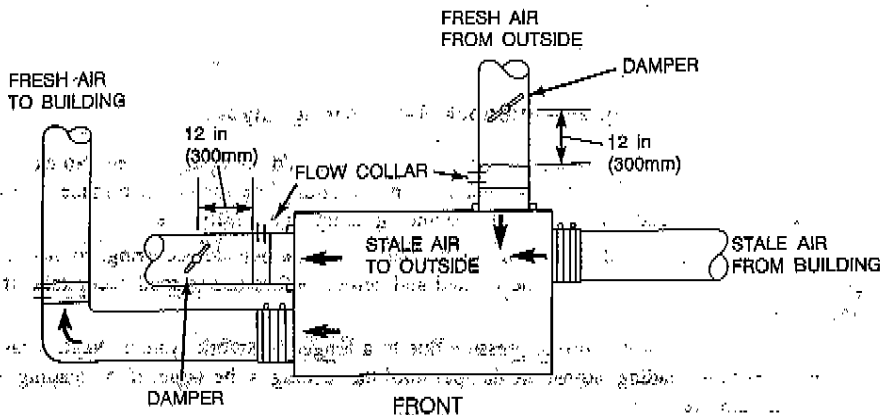
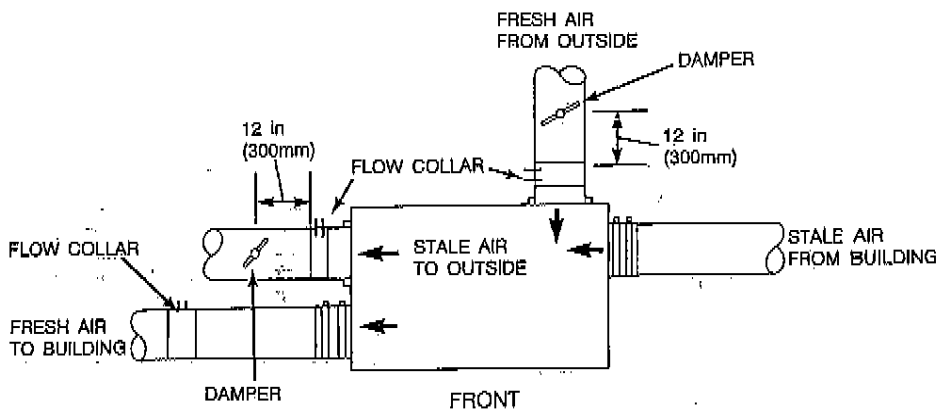

Fig. 27—Jumper Position on Circuit Board

A92396



A92403

Fig. 28—Balancing VA3A

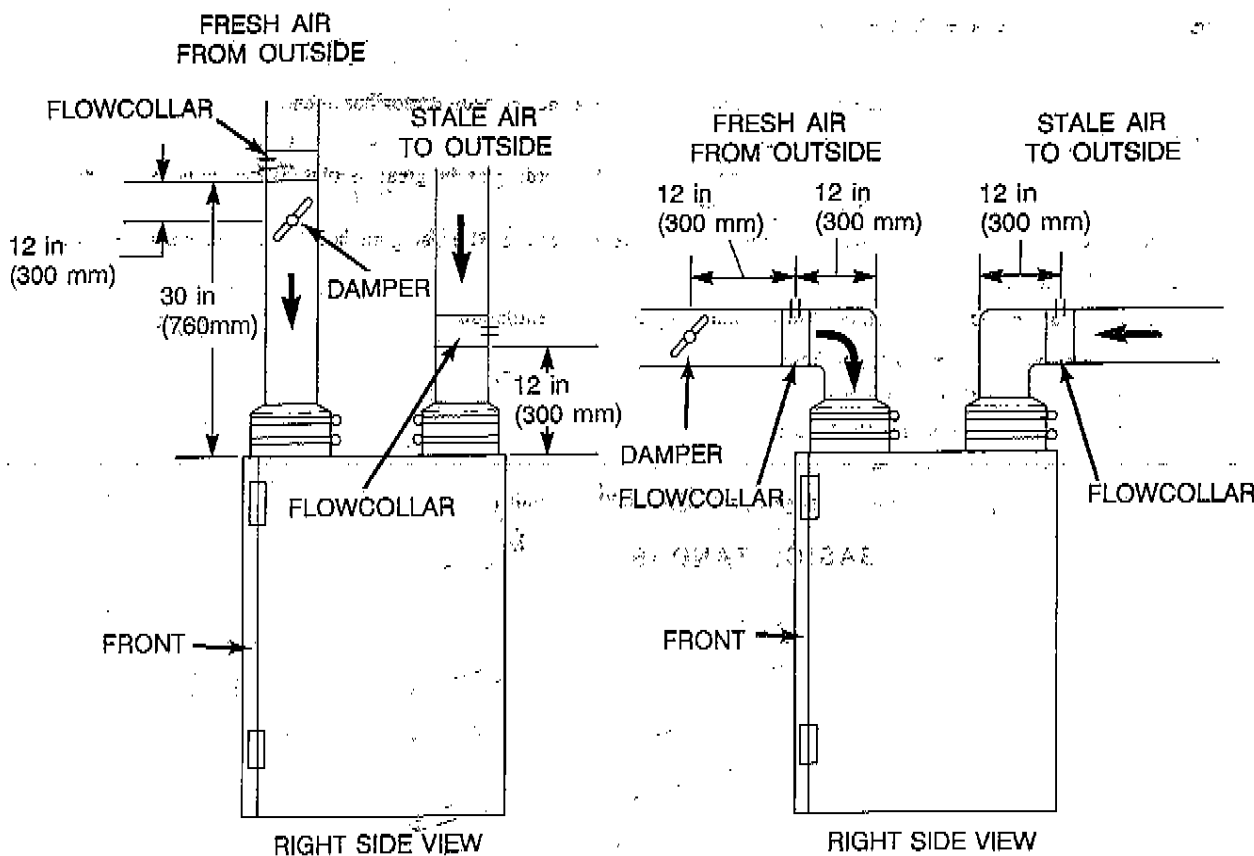

A92404

Fig. 29—Balancing VB5A and VC5A

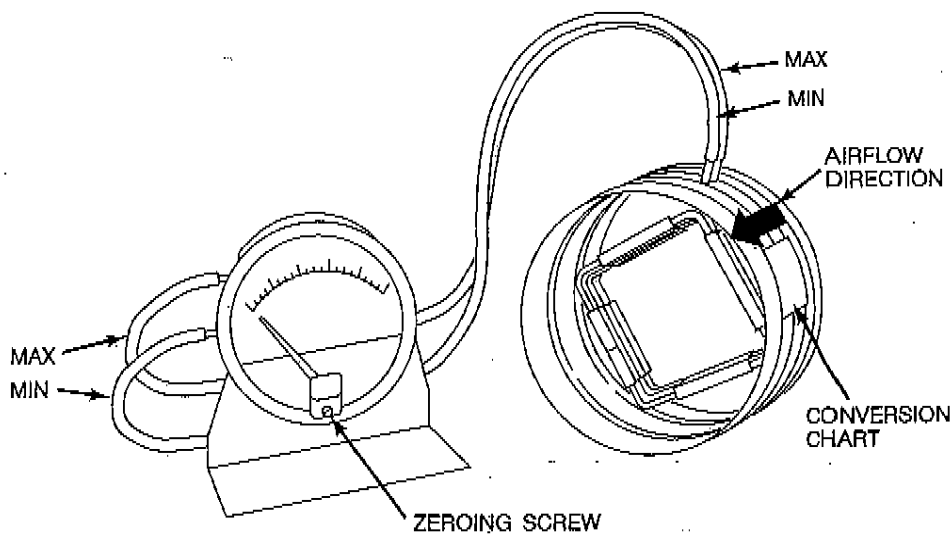

Fig. 30—Magnehelic Gage

A92273

Table 5—Troubleshooting the HRV

SYMPTOMS	CAUSES	SOLUTIONS
Air too dry	Continuous exchange mode used in small houses	Check humidity level settings
Persistent condensation on windows	Improper adjustment of control	Adjust humidity level
	Improper ventilation rate	Install a dehumidstat
Unit stops momentarily	Electrical supply interrupted	Check units circuit breaker
Wall control not operating	Broken control wire	Test wire control and wall control
Air from distribution register too cold	Improper calibration of air flow	Check calibration of flow rates
	Outdoor temperature extremely cold	Install electric duct heater if necessary
Unit makes annoying noise	Ventilation wheel out of adjustment	Remove the motor and screw the wheel on properly
Noise level too high at distribution registers when in high speed	Air duct system too short	Install a silencer

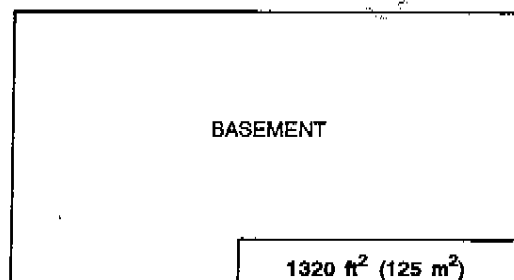
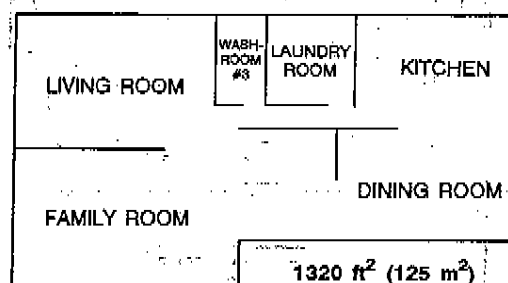
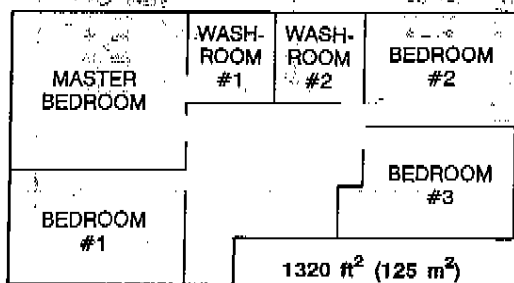

Fig. 31—Floor Plan Example

A92421

