

Installation Instructions

Energy Recovery
Ventilator

VL3A

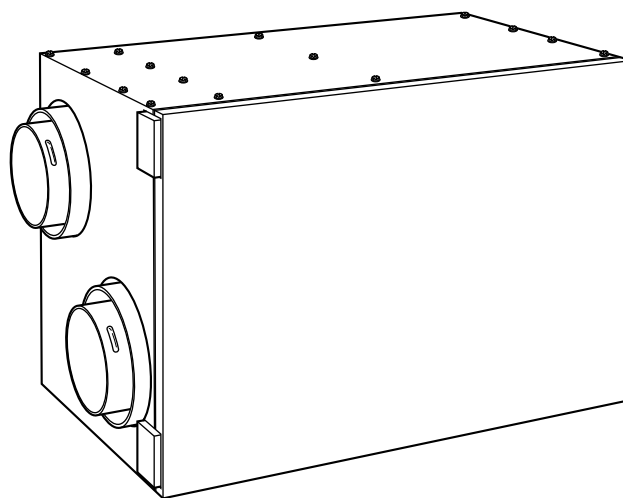

Fig. 1—VL3A Energy Recovery Ventilator

A94336

NOTE: Read the entire instruction manual before starting the installation.

SAFETY CONSIDERATIONS

Installing and servicing heating equipment can be hazardous due to gas and electrical components. Only trained and qualified personnel should install, repair, or service heating equipment.

Untrained personnel can perform basic maintenance functions such as cleaning and replacing air filters. All other operations must be performed by trained service personnel. When working on heating equipment, observe precautions in the literature, tags, and labels attached to or shipped with the unit and other safety precautions that may apply.

Follow all safety codes. In the United States, follow all safety codes including the National Fuel Gas Code NFPA No. 54-1988/ANSI Z223.1-1988. In Canada, refer to the current edition of the National Standard of Canada CAN/CGA-B149.1- and .2-M91 Natural Gas and Propane Gas Installation Codes. Wear safety glasses and work gloves. Have fire extinguisher available during start-up and adjustment procedures and service calls.

Recognize safety information. This is the safety-alert symbol . When you see this symbol on the furnace and in instructions or manuals, be alert to the potential for personal injury.

Understand the signal word DANGER, WARNING, or CAUTION. These words are used with the safety-alert symbol. DANGER identifies the most serious hazards which **will** result in severe personal injury or death. WARNING signifies a hazard which **could** result in personal injury or death. CAUTION is used to identify unsafe practices which **would** result in minor personal injury or product and property damage.

INTRODUCTION

The Energy Recovery Ventilator (ERV) is used to create an air exchange of indoor stale air with outside fresh air. Units are equipped with a energy recovery core which removes moisture and heat from the supply air in the summer.

Use this instruction to install the Energy Recovery Ventilator (ERV) system VL3A. Units have varying capacity for air exchange as noted in product data. Confirm selected unit to fits air quality requirements. (See Fig. 1.)

IMPORTANT: This unit should not be installed where the heating design temperature is below 15°F (-10°C). The ERV operates no more than one minute every three hours below this temperature.

PROCEDURE 1—INSPECT EQUIPMENT

Move carton to final installation location. Remove ERV from carton taking care not to damage unit. Inspect unit for damage. File claim with shipping company if shipment is damaged or incomplete. Check to be sure unit matches job specifications. (See Fig. 2.)

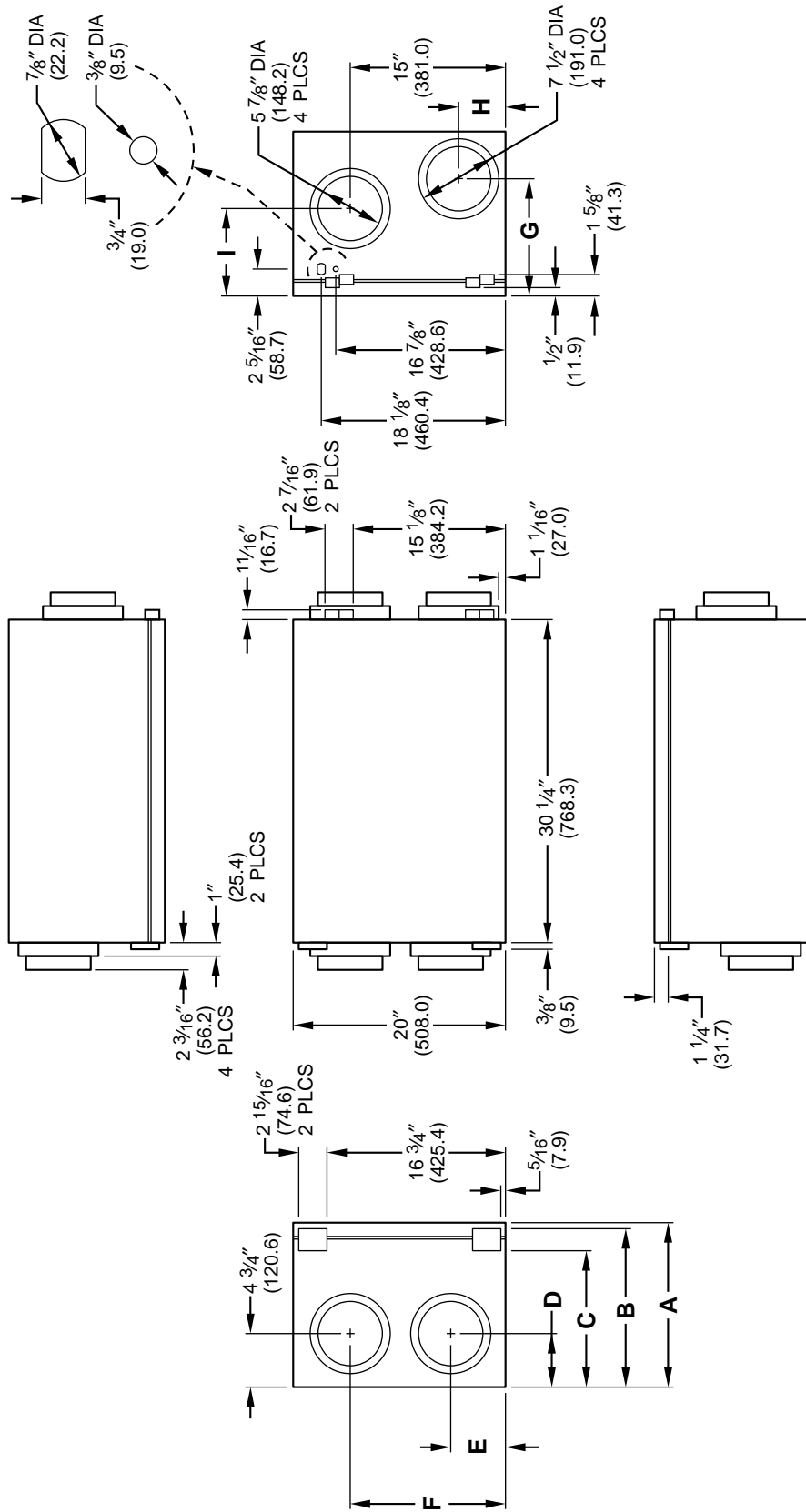

A94290

MODEL NO.	A		B		C		D		E		F		G		H		I	
	in.	mm	in.	mm	in.	mm	in.	mm	in.	mm	in.	mm	in.	mm	in.	mm	in.	mm
VL3AAA015	15-3/16	385.5	14-3/4	374.6	12-7/8	327.0	4-3/4	120.6	5-1/8	130.2	14-3/4	374.6	10-3/4	273.1	4-3/4	120.7	7-3/4	196.8
VL3AAA020	18-7/8	479.4	18-5/8	473.1	16-5/16	414.3	13-1/2	342.9	5-7/8	149.2	14	356.6	11-5/8	295.3	5-1/2	139.7	10-1/4	223.8

Fig. 2—Dimensional Drawing VL3A

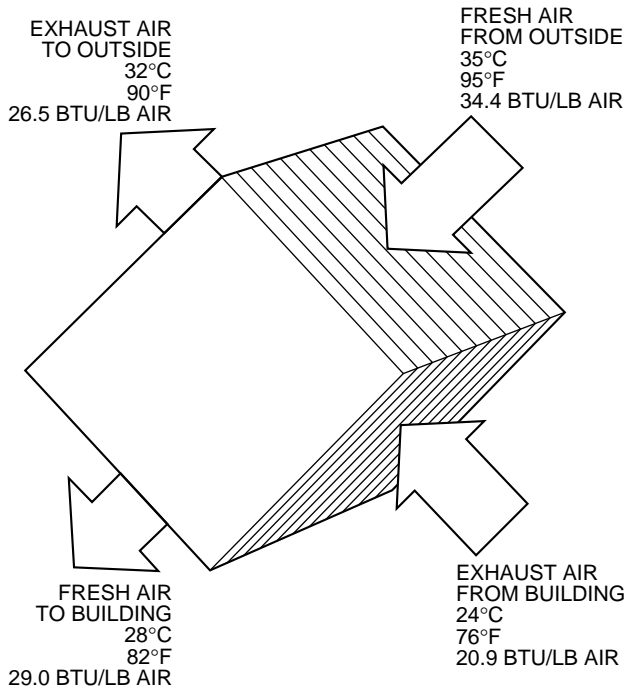

Fig. 3—VL3A Cross-Flow

A94361

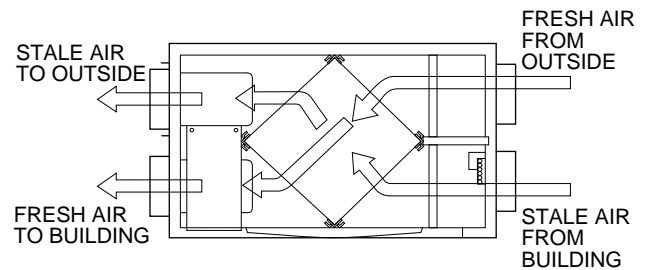

Fig. 4—VL3A Airflow During Air Exchange

A94362

AIRFLOW DIAGRAMS

The direction of the airflow is indicated in Fig. 3 and Fig. 4. Note the stale air never mixes with the fresh air.

PROCEDURE 1—FRESH AIR DISTRIBUTION

A. Forced-Air System

When the ERV is installed in conjunction with a new or existing forced-air system, the furnace or fan coil blower and network of ducts are used to distribute the fresh air inside the building. To accomplish this, the blower must operate continuously whenever the ERV is energized.

The fresh air from the ERV is introduced into the return duct at a point no less than 6 ft (2 m) upstream of the furnace or fan coil. This connection should be direct.

B. Independent System

In the absence of forced-air ductwork, the ERV requires an independent network of ducts for distribution of fresh air. Registers are normally located in the bedrooms, dining room, living room, and basement.

To ensure occupant comfort, it is recommended that register be placed 6 to 12 in. from the ceiling with airflow directed toward the ceiling. If registers are floor installed, airflow must be directed toward the wall.

PROCEDURE 2—SELECT LOCATION

The ERV should be located in close proximity to a power source. It should be easily accessible for routine maintenance.

CAUTION: No stale air pickup registers may exist in the same room as a gas furnace or water heater.

PROCEDURE 3—MOUNT THE UNIT

The ERV can be suspended from floor joists or rafters using chains and 4 springs. Attach metal hanging bracket to all 4 sides of cabinet. (See Fig. 5.)

The unit may be installed on a shelf, if a rubber bumper is provided to dampen vibration.

PROCEDURE 4—LOCATE STALE AIR INTAKE FOR SYSTEMS INDEPENDENTLY DUCTED

A. Location

Stale air is drawn from the kitchen, bathroom, basement or from other rooms where contaminants are produced. Registers must be placed 6 to 12 in. from the ceiling and 6 ft from the oven if on an interior kitchen wall.

B. Airflow

Proper type and size of registers must be used to minimize decreases in pressure. The velocity of the air flowing through the register should not be above 400 ft/minute (2 m/sec).

C. Maximum Length of Duct

The ducting system should be designed according to the highest speed of the unit. Refer to the specifications listed in the product data sheets for the ventilation capacities.

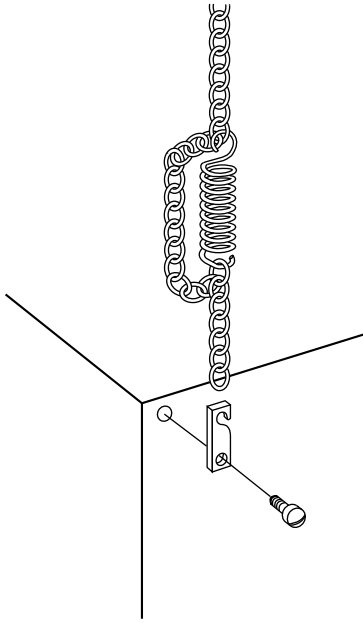

Fig. 5—Chain Spring Installation

A92269

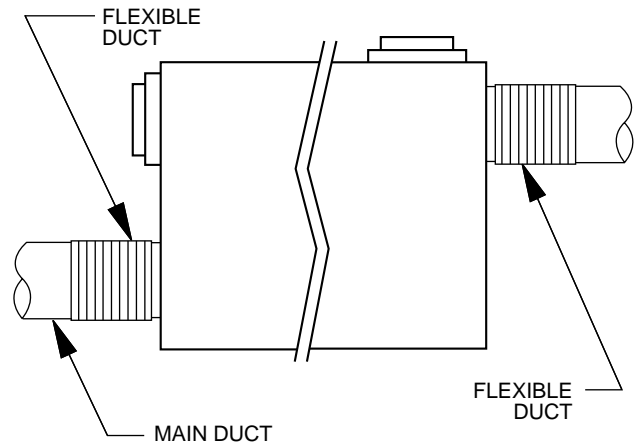

Fig. 6—Flexible Duct Fit-up

A92270

PROCEDURE 5—CONNECT DUCTS TO THE ERV

A. Ducts

NOTE: If ERV is installed in an unconditioned space, insulated flexible duct is required.

Insulated flexible ducts are required on both the fresh air inlet and the exhaust air outlet ducts connecting to the exterior. These ports are identified by their double flange collars. When using insulated flexible duct, the vapor barrier of the flexible ducts must be taped very tightly.

The 36-in. section of flexible duct supplied with the unit should be cut in half and connected to both the exhaust air port from the building and the fresh air port to the building. This is to eliminate the transmission of vibrations from the unit to the main ducts. (See Fig. 6.)

Four 30-in. duct ties are provided to fasten flexible duct to ports of the ERV.

PROCEDURE 6—COMPONENT DESCRIPTION

The following lists components of the ERV unit VL3A. (See Fig. 7 and 8.)

1. Stale air port is connected to the return-air supply.
2. Fresh air port connects to outdoor air-inlet hood.
3. Exhaust port connects to outdoor exhaust hood.
4. Mechanical filter traps dust contained in the air.
5. Energy recovery core is a cross-flow type. It transfers the sensible and latent energy between two airstreams.
6. Blowers bring in fresh air from the outside and exhaust stale air to the outside.
7. Capacitor required for motor operations.
8. Electronic control circuit ensures proper operation of unit.
9. Distribution port distributes fresh air into the house.
10. Control connector allows connections with control wiring.
11. Electrical cord connects to standard 120v outlet.

PROCEDURE 7—LOCATE AND INSTALL EXTERIOR HOODS

A. Location

The fresh air intake and the stale air exhaust must be separated by at least 6 ft (2 m). The fresh air intake must be positioned at least 10 ft (3 m) from the nearest dryer vent, furnace exhaust, driveway, gas meter, or oil fill pipe. The fresh air intake must be positioned as far as possible from garbage containers and potential chemical fumes. When possible, it is advised to locate the intake and exhaust on opposite walls of the building or around a corner from each other. The exhaust and supply hoods should never be located on interior corners or in dead air pockets. (See Fig. 9.) Both intake and exhaust hoods must be 18 in. from the ground and at least 12 in. above the anticipated snow level.

Both the intake and exhaust hoods must be supplied with a rodent screen. Wire mesh of 1/4 in. (6mm) is recommended. Smaller mesh screens must be easily removed for cleaning. The free area of the exterior hoods must be equivalent to the connecting diameter of the ERV.

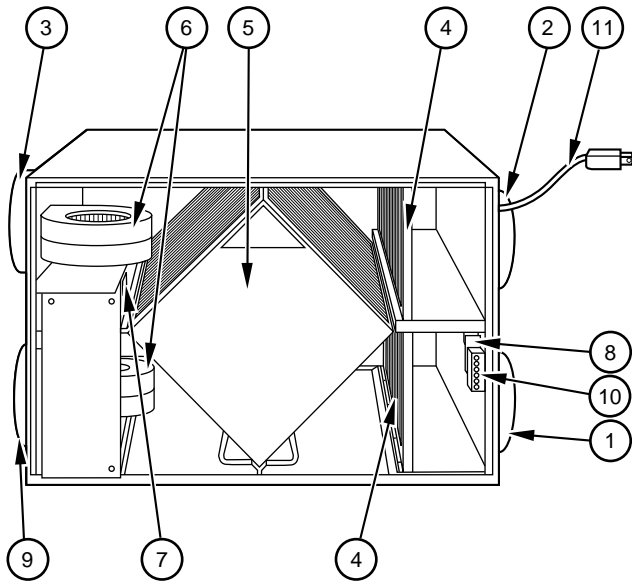

Fig. 7—VL3AAA015 with 1 PSC Motor

A94363

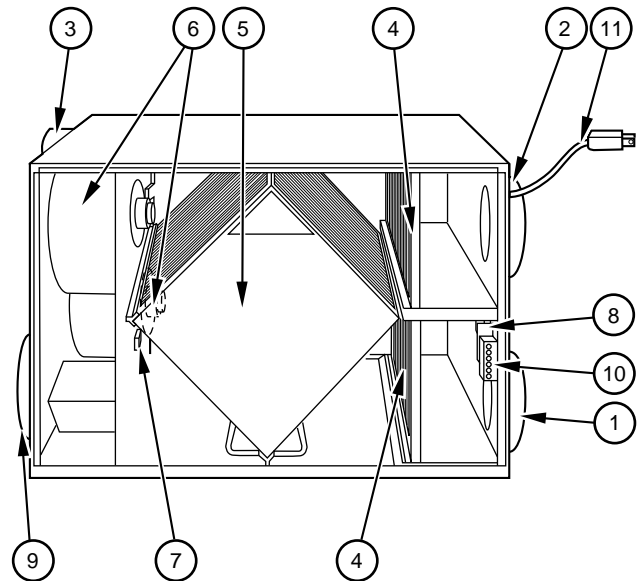

Fig. 8—VL3AAA020 with 2 PSC Motors

A94364

B. Installation

Insulated flexible duct is required for both inlet and outlet outside connections to the ERV. After making the appropriate sized wall penetration, pass the flexible duct through the penetration and insert the hood tube into the duct. Tape the duct vapor barrier tightly around the hood tube and insert the assembly back into the wall penetration and fasten securely.

PROCEDURE 8—INSTALL WALL CONTROLS

A. Location

Install the wall control on ground floor of building. Locate as close as possible to the main thermostat, or within the flow of circulated fresh air. Position wall control approximately 60 in. (1.5 m) above floor.

B. Wall Control and Wiring

Connect wire to the wall control following the color code. Attach wall control to wall. (See Fig. 10.) Following the color code, connect wire to the unit by passing it through the hole located on top or right side of unit. (See Fig. 11.)

LATENT CONTROL

NOTE: To ensure the highest degree of humidity control in cooling season, the intermittent mode should be used.

There are 2 operating modes available. (See Table 1.) The slide switch allows selection of the following:

1. With the switch off the ERV is inoperative and both LED's are extinguished.
2. The low exchange mode continually exchanges air with the outside. If the humidity in the space is below the setpoint, the air exchange is on high speed. Otherwise the unit is on low speed. Both LEDs are illuminated at all times.
3. The intermittent mode exchanges air with the outside at high speed and shuts the unit down when humidity level reaches the set point. The on LED is illuminated at all times and the exchange LED is illuminated while the unit is running. This mode is ideal for maintaining the proper humidity level when the continuous mode cannot. To ensure the highest degree of humidity control in cooling season, the intermittent mode should be used.

PROCEDURE 9—HUMIDITY SELECTION

The Humidity Selector is a built-in humidity controller designed to properly control the level of humidity in the house during summer months. Follow the chart provided in Table 2 to select the maximum level of humidity.

If the house becomes too dry in the winter months, put the wall control in Intermittent Mode and turn down humidity selector to provide ventilation less frequently.

PROCEDURE 10—CHECK CONTROLS' OPERATING MODES

Be sure that all modes of operation are fully functional. Table 1 indicates the available modes of operation with the ERV. Use the wiring diagram and logic diagram to help locate the board components and the wires connection them.

NOTE: The jumper settings on the board must be the same as those listed in the jumpers table on the wiring diagram to ensure correct operation. (See Fig. 12.) The jumpers are set at the factory for the ERV.

NOTE: The Blower Interlock Relay KVAAC0101FIR is required when installing the ERV into a forced air heating and cooling system. (See Fig. 13.)

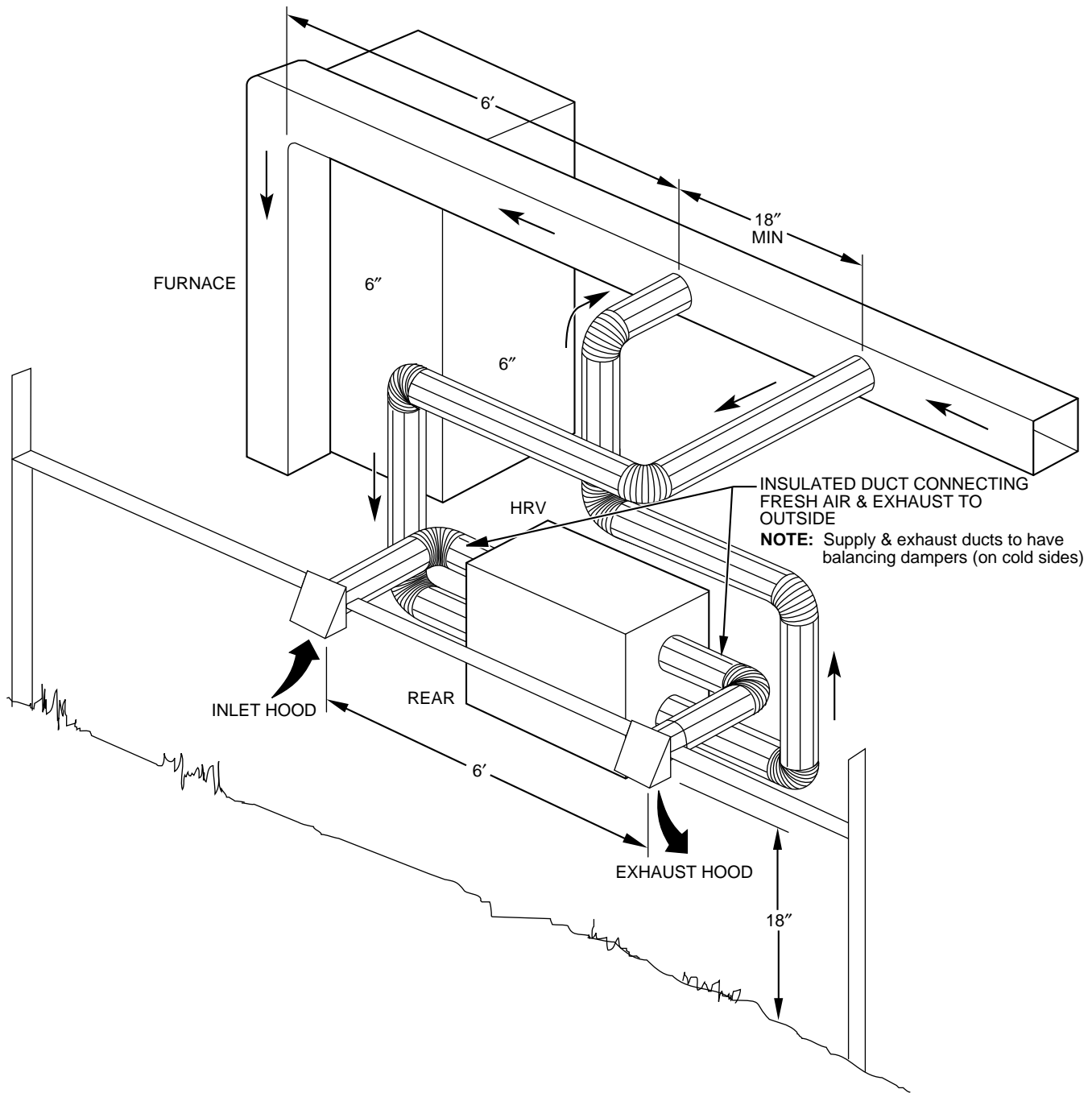

Fig. 9—Exhaust Ventilation

A94365

A. Board Function

BELOW 15°F (-10°C)

The ERV checks the outside air temperature and decides whether or not the outside air is too cold. If the outside air is at or below 15°F, the ERV will not operate for three hours to prevent freezing the energy exchanger core. When the air is too cold, the board function is below 15°F. If the outside air is still too cold after three hours, this board function repeats.

Relay K1 is open for three hours and K2 is energized, closing the high speed contacts and opening the low speed contacts. When the three hours have expired, the control board checks the wall control and returns to the mode of operation before the ERV was shut off. If the outside air is still too cold, this board function repeats.

OFF/INTERMITTENT

Relay K1 remains open and ERV is off.

EXCHANGE HIGH

Relay K1 closes. The 12vdc relay K2 is then energized, breaking low speed contacts and closing high speed contacts. The 115vac is applied between the orange and gray wires on the molex plug (pin 1 and 6) and the motor, running the ERV in high speed. The 115vac is applied across pin 5 and 7, energizing the blower interlock relay. The G is broken between the thermostat and fan coil or furnace control board while making R and G at the fan coil or furnace, operation the blower.

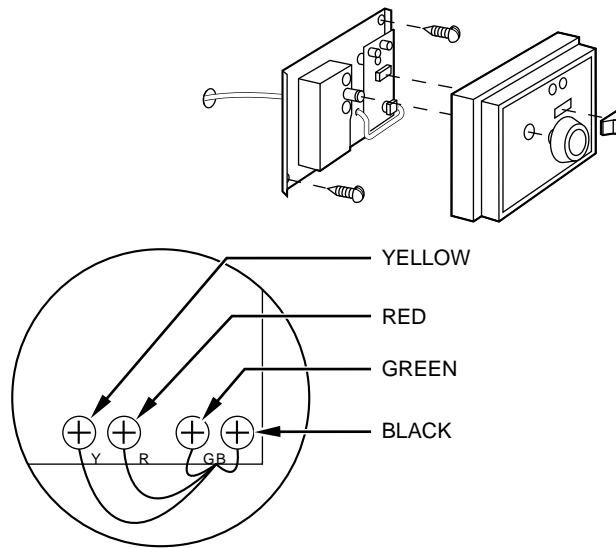

Fig. 10—Typical Wall Control

A92272

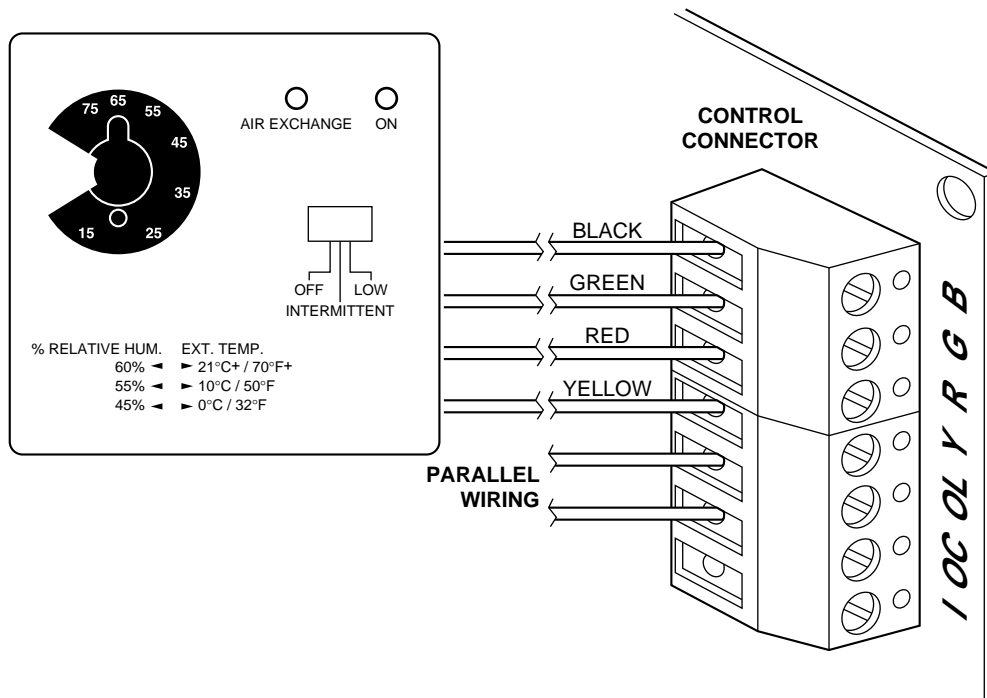

Fig. 11—Control Connector

A95077

EXCHANGE LOW

Relay K1 closes. The 12vdc relay K2 remains unenergized, keeping low speed relay contacts closed and high speed contacts open. The 115vac is applied between the Red and Gray wires on the molex plug (pins 4 and 1) and the motor, operating the ERV at low speed. The 115vac is applied across pins 5 and 7, energizing the blower interlock relay. The G is broken between the thermostat and fan coil or furnace control board while making R and G at the fan coil or furnace, operating the blower.

PROCEDURE 11—MISCELLANEOUS CONTROLS

A. Blower Interlock Relay

NOTE: To distribute the fresh air throughout the house, the Blower Interlock Relay is required when installing ERV into a forced air heating and cooling system.

The Blower Interlock Relay kit KVAAC0101FIR provides the best way to tie the operation of the furnace or fan coil blower to the ERV. When the ERV is operation, the interlock relay is also energized; energizing the G terminal inside the furnace or fan coil. This allows continuous blower operation circulation both fresh air and return air throughout the ducted system. (See Fig. 12 and 13.)

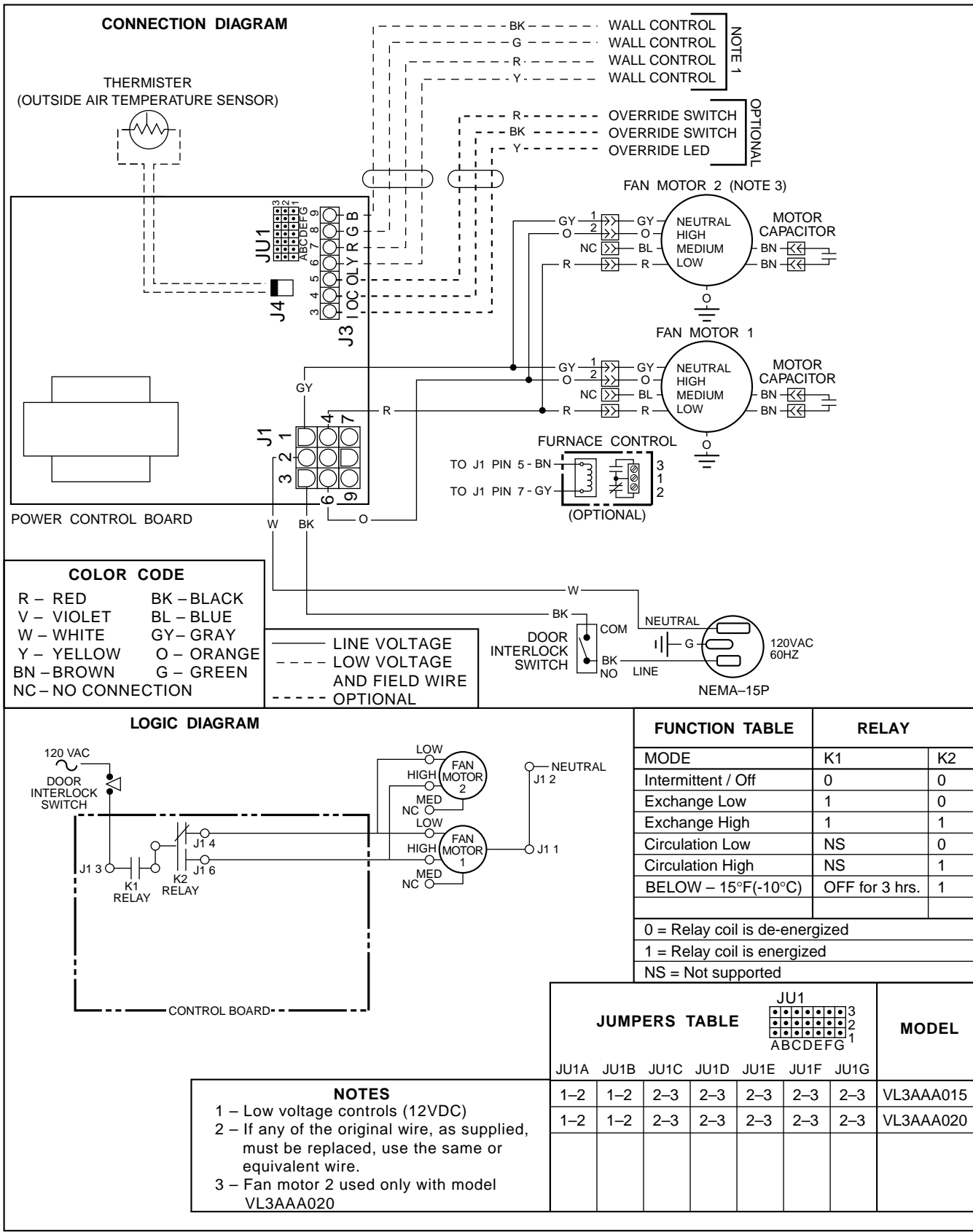

LOGIC DIAGRAM

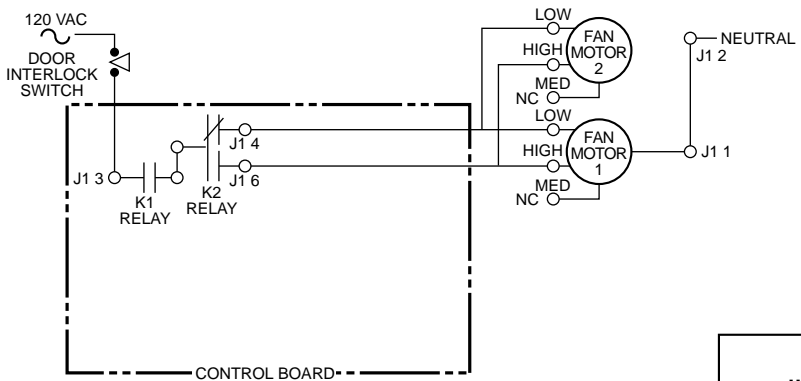

FUNCTION TABLE	RELAY	
	K1	K2
MODE	0	0
Intermittent / Off	0	0
Exchange Low	1	0
Exchange High	1	1
Circulation Low	NS	0
Circulation High	NS	1
BELOW - 15°F (-10°C)	OFF for 3 hrs.	1
0 = Relay coil is de-energized		
1 = Relay coil is energized		
NS = Not supported		

JUMPERS TABLE							MODEL
JU1A	JU1B	JU1C	JU1D	JU1E	JU1F	JU1G	
1-2	1-2	2-3	2-3	2-3	2-3	2-3	VL3AAA015
1-2	1-2	2-3	2-3	2-3	2-3	2-3	VL3AAA020

- NOTES**
- 1 - Low voltage controls (12VDC)
 - 2 - If any of the original wire, as supplied, must be replaced, use the same or equivalent wire.
 - 3 - Fan motor 2 used only with model VL3AAA020

Fig. 12—Wiring Diagram

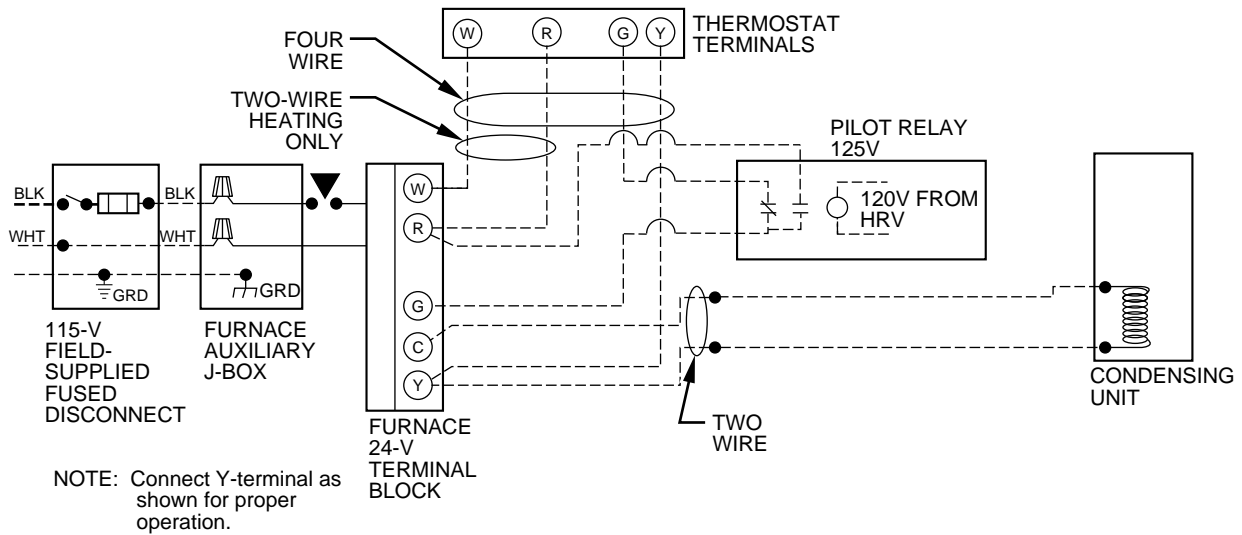

A92402

Fig. 13—Interlock Relay Wiring Layout

Table 1—Standard Controls

MODE	HUMIDITY LEVEL	BOARD FUNCTION	FAN SPEED	INDICATOR LED'S
Off	Any	Off/Intermittent	Off	OFF
Low	Below Setpoint	Exchange High	High	Both ON
	Above Setpoint	Exchange Low	Low	
Intermittent	Below Setpoint	Exchange High	High	Both On
	Above Setpoint	Off/Intermittent	Off	ON light on Exchange OFF
Below 15°F (-10°C)	Any	Below 15°F (-10°C)	Off 3 Hours	ON light on Exchange OFF

Table 2—Maximum Humidity Levels

OUTSIDE TEMPERATURE		PERCENT RELATIVE HUMIDITY
70°F and Above	21°C and above	60 percent
50°F	10°C	55 percent
32°F	0°C	45 percent

INSTALLATION OF THE BLOWER INTERLOCK RELAY

To install KVAAC0101FIR, use the instructions provided with the kit. The necessary hardware to mount the relay and relay cover inside the unit, are provided below the control box.

B. Timers

20 MINUTE TIMER

A push button can be used to override the wall control and put the ERV into high speed for 20 minutes. Connect the switches in parallel and leads to ERV terminals I, OC, and OL. (See Fig. 14.)

60 MINUTE ADJUSTABLE TIMER

Also available is a 60 minute timer kit KVATM0010160M which provides 30 to 80 minutes of ventilation at high speed. The additional 20 minutes are the result of a timer internal to the control board. Wire the timer to OC and OL to connect to ERV.

PROCEDURE 12—BALANCING

The arrow on the flow collar is always oriented with the airflow.

TEMPORARY FLOW COLLARS

NOTE: Flexible connectors should be located suitably to measure airflow. Always try to locate flow measuring collars in the straightest sections of duct to ensure accuracy. (See Fig. 15.) If only one flow collar is available, the flow collar is mounted in stale air duct of the ERV, and the airflow recorded. The flow collar is then relocated to the fresh-air duct, and airflow is recorded again. Dampers can then be adjusted to equalize airflow. The procedure should be repeated to ensure the unit is balanced properly.

Balancing is very important to proper operation of a ERV. If supply air from outside is greater than exhaust air from the house, the imbalance can result in house being overpressurized. If exhaust air from the house is greater than the supply air from the outside, combustion appliances may backdraft, bringing exhaust fumes into the house. A balanced condition will ensure optimum performance, provide satisfied customers, and avoid expensive callbacks. Installation of the balancing dampers in insulated ducts is strongly recommended.

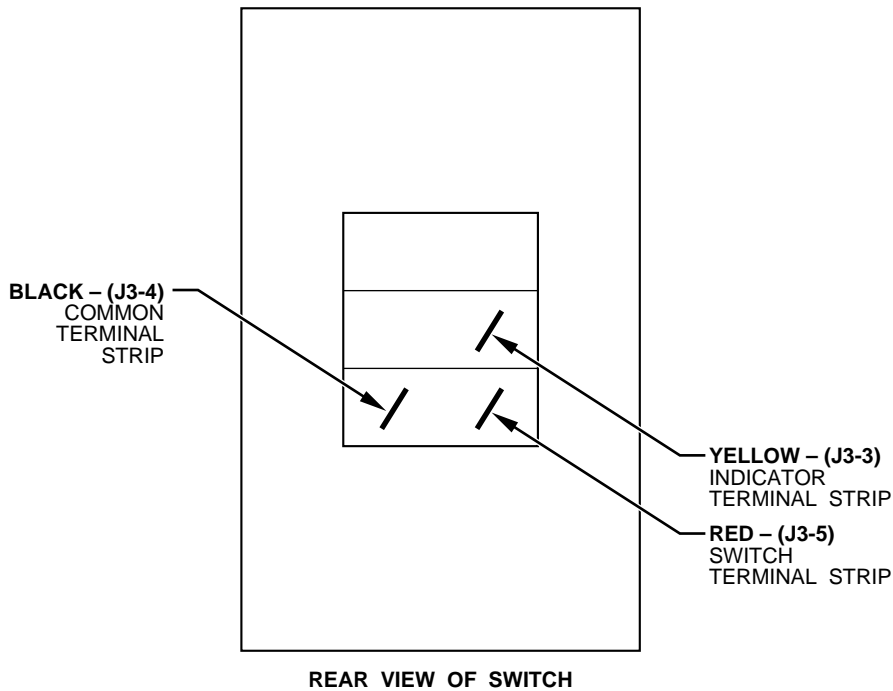
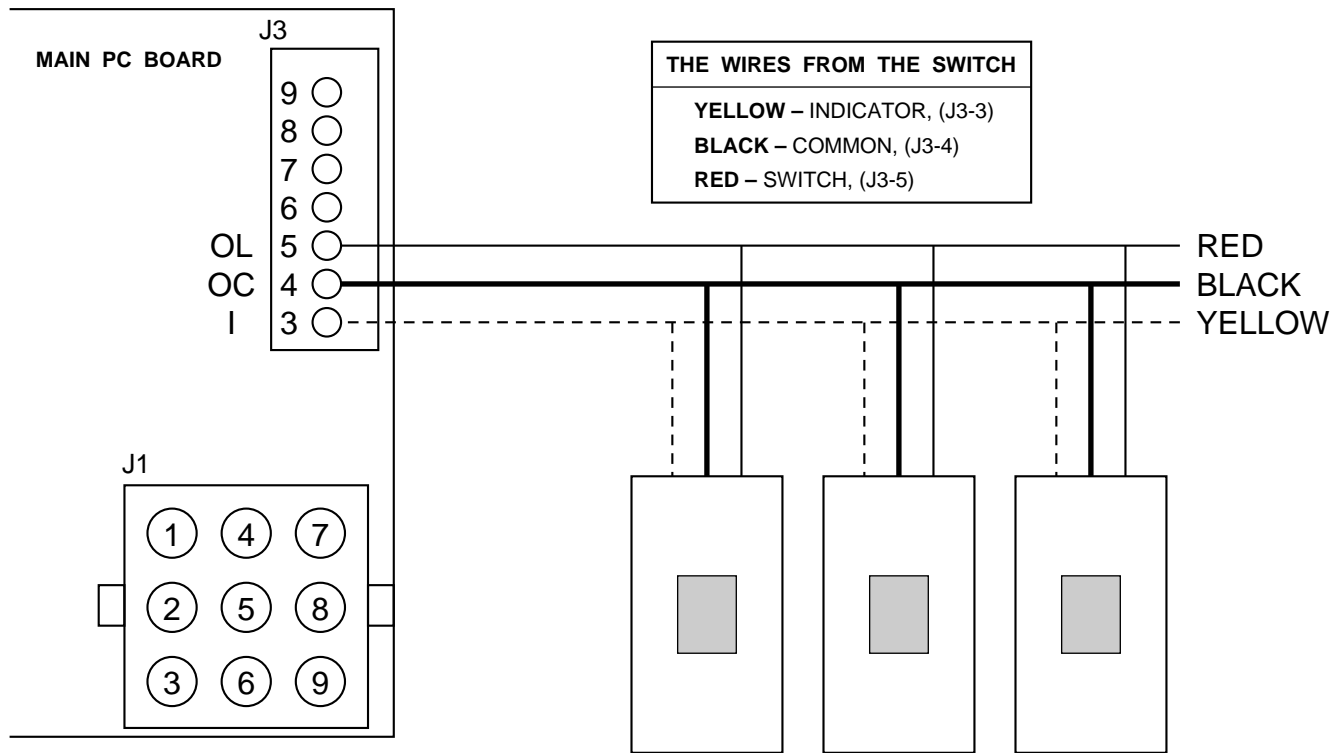

Fig. 14—Push Button Timer Wiring Layout

A92399

1. Before proceeding with balancing, all windows, doors, and fireplace flues should be tightly closed. No exhaust systems such as range top exhausts, dryer exhaust, fume hoods, bath or roof fans should be in operation. The forced-air furnace, if used for circulation, should be operating at its continuous operating speed. Ensure that the balancing dampers are fully open.
2. With the speed control at maximum speed and continuous air exchange with the outside occurring, connect the hoses from the flow collar to a magnehelic gage. (See Fig. 16.) The gage must be leveled and zeroed before use to read accurately. If the needle falls below zero, reverse the hose connections.

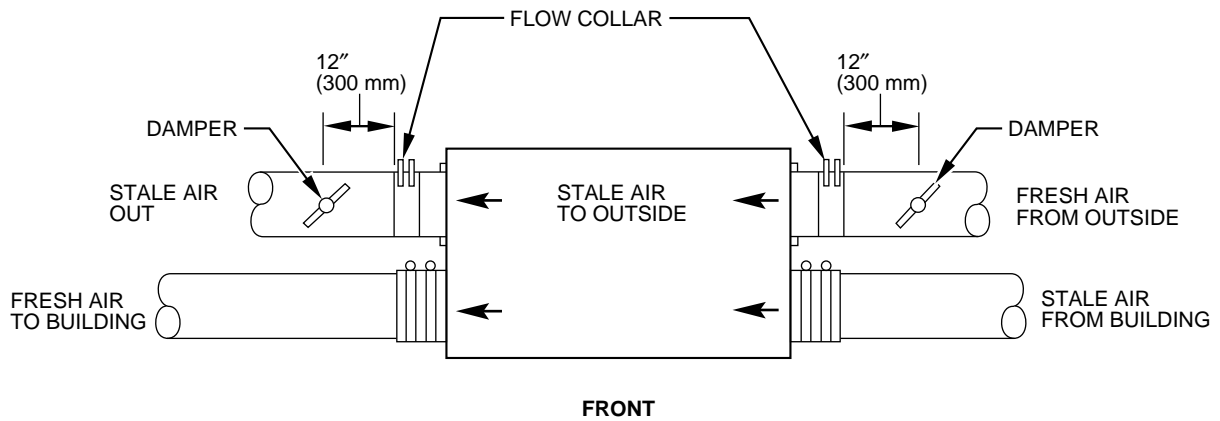

Fig. 15—Balancing VL3A

A94367

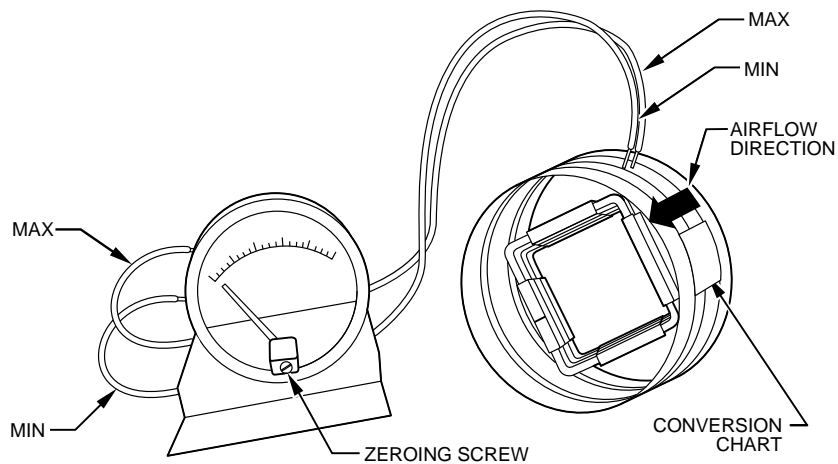

Fig 16—Magnehelic Gage

A92273

3. Measure the exhaust air first as it is often the lowest pressure due to a longer ductwork system. Next, measure the fresh air. If the fresh air reading is higher than the exhaust reading, adjust the damper until the reading is the same. If the reading is lower, return the grid to the exhaust damper to obtain the same reading.

⚠ CAUTION: Do not use ERV during the construction of a house or when sanding drywall. This type of dust may damage the system.

PROCEDURE 13—VENTILATION EVALUATION

Two methods used to evaluate the ventilation needs of a house are:

1. The sum of rooms x 10 cfm (5 l/s) per room, plus 20 cfm (10 l/s) for a master bedroom or basement.
2. Air exchange at 0.3 per hr x the volume of the house.

The ventilation capacity of the ERV unit while at maximum speed is defined according to the greatest total. These methods are derived from the National Building Code 1990 version and the CSA F326.1 revision.

In the illustration, there are 11 noted rooms, a master bedroom and a basement. (See Fig. 17.) Using method 1 to calculate approximate ventilation:

$$1. (11 \times 10 \text{ cfm}) + (2 \times 20 \text{ cfm}) = 150 \text{ cfm}$$

Referring to the same illustration and using method 2 to calculate approximate ventilation:

1. 1320 sq ft x 8 ft in height = 10560 cu ft per floor
2. 10560 cu ft x 3 floors = 31680 cu ft in house
3. 31680 cu ft x 0.3 air change per hour = 9500 cu ft
4. 9500 cu ft ÷ 60 min per hour = 160 cfm

The greatest total is 160 cfm, a capacity within the range of a VL3AAB020 size unit.

Table 3—Troubleshooting the ERV

SYMPTOMS	CAUSES	SOLUTIONS
Air too humid	Continuous exchange mode used in small houses	Use Intermittent Mode Check humidity level settings
Unit not responding to wall control	Frost condition is in effect Outdoor temperature is below 15°F (-10°C)	Unit will operate at wall control setting when outside air temperature warms above 15°F (-10°C)
	Broken wire control	Test wall control Check connections
Unit stops momentarily	Electrical supply interrupted	Check units circuit breaker
Air from distribution register too cold	Improper calibration of air flow	Check calibration of flow rates
Unit makes annoying noise	Ventilation wheel out of adjustment	Remove the motor and screw the wheel on properly
Noise level too high at distribution registers when in high speed	Air duct system too short	Install a silencer

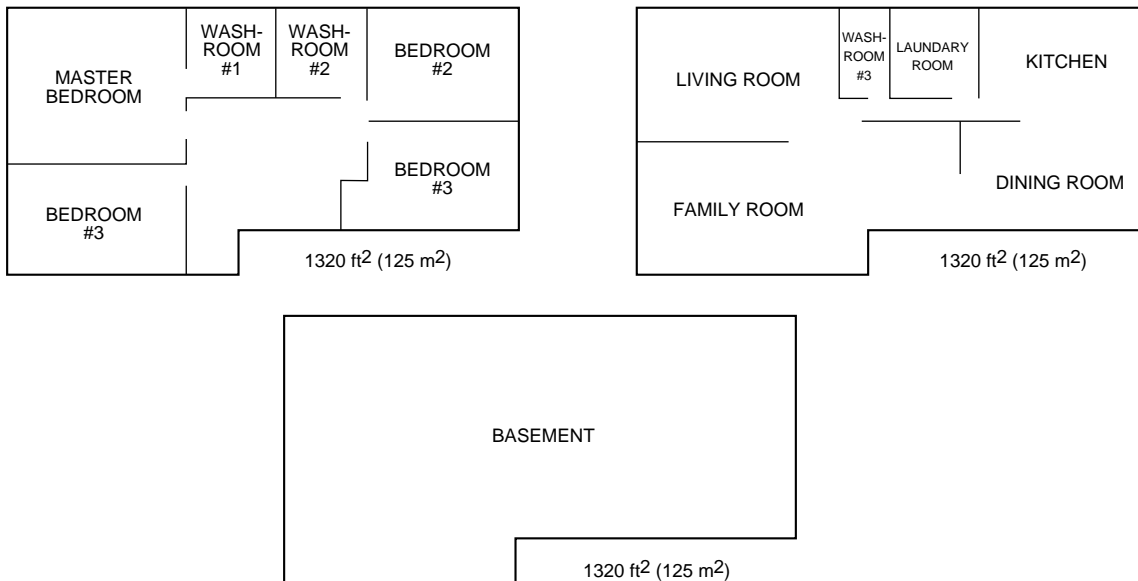

Fig. 17—Floor Plan Example

A92421