

# RTSS Load Shed Automatic Transfer Switch



Model No. KGALT0101200



## TECHNICAL MANUAL





This manual should remain with the unit.



 **SAVE THESE INSTRUCTIONS** - This manual contains important instructions that should be followed during installation and maintenance of the generator and batteries. 

 **SAVE THESE INSTRUCTIONS!** Read the following information carefully before attempting to install, operate or service this equipment. Also read the instructions and information on tags, decals, and labels that may be affixed to the transfer switch. Replace any decal or label that is no longer legible. 

 **DANGER!** Connection of a generator to an electrical system normally supplied by an electric utility shall be by means of suitable transfer equipment so as to isolate the electric system from utility distribution system when the generator is operating (Article 701 Legally Required Standby Systems or Article 702 Optional Standby Systems, as applicable). Failure to isolate electric system by these means may result in damage to generator and may result in injury or death to utility workers due to backfeed of electrical energy. 

The manufacturer cannot anticipate every possible circumstance that might involve a hazard. The warnings in this manual, and on tags and decals affixed to the unit are, therefore, not all-inclusive. If using a procedure, work method or operating technique the manufacturer does not specifically recommend, ensure that it is safe for others. Also make sure the procedure, work method or operating technique chosen does not render the transfer switch unsafe.

Throughout this publication, and on tags and decals affixed to the generator, DANGER, WARNING, CAUTION and NOTE blocks are used to alert personnel to special instructions about a particular operation that may be hazardous if performed incorrectly or carelessly. Observe them carefully. Their definitions are as follows:

—  **DANGER**  —

After this heading, read instructions that, if not strictly complied with, will result in personal injury, including without limitation, death, or property damage.

—  **WARNING**  —

After this heading, read instructions that, if not strictly complied with, may result in personal injury or property damage.

—  **CAUTION**  —

After this heading, read instructions that, if not strictly complied with, could result in damage to equipment and/or property.

**NOTE:**

After this heading, read explanatory statements that require special emphasis.

These safety warnings cannot eliminate the hazards that they indicate. Common sense and strict compliance with the special instructions while performing the service are essential to preventing accidents.

Four commonly used safety symbols accompany the DANGER, WARNING and CAUTION blocks. The type of information each indicates follows:

 This symbol points out important safety information that, if not followed, could endanger personal safety and/or property.

 This symbol points out potential explosion hazard.

 This symbol points out potential fire hazard.

 This symbol points out potential electrical shock hazard.

 **GENERAL HAZARDS** 

- Any AC generator that is used for backup power if a NORMAL (UTILITY) power source failure occurs, must be isolated from the NORMAL (UTILITY) power source by means of an approved transfer switch. Failure to properly isolate the NORMAL and STANDBY power sources from each other may result in injury or death to electric utility workers, due to backfeed of electrical energy.
- Improper or unauthorized installation, operation, service or repair of the equipment is extremely dangerous and may result in death, serious personal injury, or damage to equipment and/or personal property.
- Extremely high and dangerous power voltages are present inside an installed transfer switch. Any contact with high voltage terminals, contacts or wires will result in extremely hazardous, and possibly LETHAL, electric shock. **DO NOT WORK ON THE TRANSFER SWITCH UNTIL ALL POWER VOLTAGE SUPPLIES TO THE SWITCH HAVE BEEN POSITIVELY TURNED OFF.**

- Competent, qualified personnel should install, operate and service this equipment. Adhere strictly to local, state and national electrical and building codes. When using this equipment, comply with regulations the National Electrical Code (NEC), CSA Standard; C22.1 Canadian Electric Code and Occupational Safety and Health Administration (OSHA) have established.
- Never handle any kind of electrical device while standing in water, while barefoot, or while hands or feet are wet. **DANGEROUS ELECTRICAL SHOCK MAY RESULT.**
- Jewelry conducts electricity and wearing it may cause dangerous electrical shock. Remove all jewelry (such as rings, watches, bracelets, etc.) before working on this equipment.
- If work must be done on this equipment while standing on metal or concrete, place insulative mats over a dry wood platform. Work on this equipment only while standing on such insulative mats.
- Never work on this equipment while physically or mentally fatigued.
- Keep the transfer switch enclosure door closed and bolted at all times. Only qualified personnel should be permitted access to the switch interior.
- In case of an accident caused by electric shock, immediately shut down the source of electrical power. If this is not possible, attempt to free the victim from the live conductor but **AVOID DIRECT CONTACT WITH THE VICTIM.** Use a nonconducting implement, such as a dry rope or board, to free the victim from the live conductor. If the victim is unconscious, apply first aid and get immediate medical help.
- When an automatic transfer switch is installed for a standby generator set, the generator engine may crank and start at any time without warning. To avoid possible injury that might be caused by such sudden start-ups, the system's automatic start circuit must be disabled before working on or around the generator or transfer switch. For that purpose, a **SAFETY DISCONNECT** is provided inside the transfer switch. Always set that switch to its **OFF** position before working on the equipment. Then place a "DO NOT OPERATE" tag on the transfer switch and on the generator. Remove the Negative (Neg) or (-) battery cable.

**Safety Rules .....Inside Front Cover**

**Section 1 – General Information .....2**

1.1 Introduction..... 2

1.2 Equipment Description ..... 2

    1.2.1 Transfer Switch Mechanism..... 2

    1.2.2 Utility Service Disconnect Circuit Breaker .... 3

    1.2.3 Load Shed Controller ..... 3

    1.2.4 Battery Charger ..... 3

1.3 Transfer Switch Data Decal..... 3

1.4 Transfer Switch Enclosure ..... 3

1.5 Safe Use Of Transfer Switch..... 4

**Section 2 – Installation .....4**

2.1 Introduction to Installation..... 4

2.2 Unpacking ..... 4

2.3 Mounting ..... 4

2.4 Connecting Power Source and Load Lines..... 4

2.5 Neutral Connections ..... 5

2.6 Connecting Control Wires ..... 5

**Section 3 – Operation.....5**

3.1 Functional Tests & Adjustments ..... 5

3.2 Manual Operation..... 6

    3.2.1 ATS Manual Operation ..... 6

    3.2.2 LSS Manual Operation ..... 6

    3.2.3 Close to Utility Source Side..... 7

    3.2.4 Close to Generator Source Side ..... 7

    3.2.5 Return to Utility Source Side ..... 7

3.3 Voltage Checks..... 7

3.4 Generator Tests Under Load ..... 8

    3.4.1 ATS & Critical Loads..... 8

    3.4.2 Load Shed Functional Test ..... 9

**Section 4 – Installation Diagrams .....10**

**Section 5 – Electrical Data .....12**

**Section 6 – Exploded Views & Parts Lists .....16**

**Section 7 – Notes ..... 20**

**Section 8 – Warranty ..... Back Cover**

## 1.1 INTRODUCTION

This manual has been prepared especially for the purpose of familiarizing personnel with the design, application, installation, operation and servicing of the applicable equipment. Read the manual carefully and comply with all instructions. This will help to prevent accidents or damage to equipment that might otherwise be caused by carelessness, incorrect application, or improper procedures.

Every effort has been expended to make sure that the contents of this manual are both accurate and current. The manufacturer, however, reserves the right to change, alter or otherwise improve the product at any time without prior notice.

## 1.2 EQUIPMENT DESCRIPTION

The PowerManager™ LTS transfer switch will provide three major functions.

**The first function** is to provide an automatic transfer switch. The automatic transfer switch is used for transferring electrical loads from a UTILITY (NORMAL) power source to a GENERATOR (STANDBY) power source. Such a transfer of electrical loads occurs automatically when (connected to an engine generator) the UTILITY power source has failed or is at a substantially reduced voltage and the GENERATOR source voltage and frequency have reached an acceptable level. The transfer switch prevents electrical feedback between two different power sources (such as the UTILITY and GENERATOR sources) and, for that reason, codes require it in all standby electrical system installations.

**The second function** is to provide a means to divide up the electrical loads on the electrical system. The electrical loads are to be divided into “critical loads” and non-essential loads. The “critical” loads are connected to the internal 16 circuit panel board. The non-essential electrical loads are to be powered from the load shed switch (LSS).

The UTILITY source will supply all electrical loads at all times. When the transfer signal is given by the engine generator controller, all loads, both critical and non-essential loads, are connected to the GENERATOR supply. If the generator is overloaded the LSS will operate and disconnect the non-essential loads which results in a reduction in the load on the generator.

**The third function** is a 16 circuit load center to connect the “critical loads” to. These loads will be normally powered by the UTILITY source and will be backed up by the GENERATOR source. The Siemens load center is provided with the following Siemens type QP circuit breakers; 1-50A 2-pole, 1-40A 2-pole, 1-20A 2-pole, 5-20A single pole and 5-15A 2-pole circuit breakers.

The PowerManager LTS transfer switch is suitable for use as SERVICE ENTRANCE EQUIPMENT – UTILITY (NORMAL) source only. The PowerManager LTS is only SERVICE ENTRANCE rated for the USA. The 200A 2-pole circuit breaker provided is the “service disconnect” and is labeled as such. An additional disconnect must be readily available for the alternate source, unless the alternate source is an accessible generator and can be shutdown.

### ◆ 1.2.1 TRANSFER SWITCH MECHANISM

These switches (Figure 1.1) are used with a single-phase system, when the single-phase NEUTRAL line is to be connected to a Neutral Lug and is not to be switched.

Solderless, screw-type terminal lugs are standard.

Switch Rating	Wire Range	Conductor Tightening Torque
200A	#6-250 MCM	275 in-lbs.

This transfer switch is suitable for control of motors, electric discharge lamps, tungsten filament and electric heating equipment where the sum of motor full load ampere ratings and the ampere ratings of other loads do not exceed the ampere rating of the switch and the tungsten load does not exceed 30 percent of the switch rating.

**Figure 1.1 — Typical ATS Transfer Mechanism**

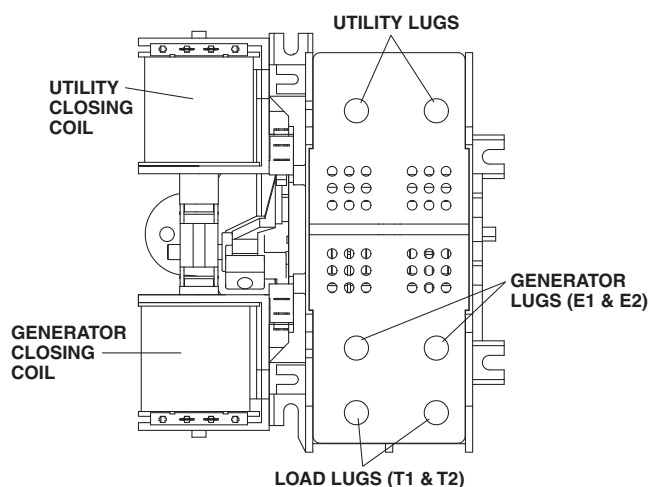

This transfer switch is for use in optional standby systems only (NEC® Article 702).

This transfer switch is suitable for use on a circuit capable of 22,000 rms symmetrical amperes, 240 VAC maximum.

### ◆ 1.2.2 UTILITY SERVICE DISCONNECT CIRCUIT BREAKER

The utility service disconnect circuit breaker for the 200 amp models are:

- Type 225AF, 2-pole
- 120/240VAC, 200A
- 50/60 Hertz
- Wire range: 300 MCM - 6 STR (Line), 250 MCM - 6 STR (Load)
- The conductor tightening torque is 375 in-lbs. (Line), 275 in-lbs. (Non-essential Load and Generator Terminals)

### ◆ 1.2.3 LOAD SHED CONTROLLER

The primary function of the Load Shed Controller (LSC) is to determine when there is excess load on the generator and has the ability to disconnect the non-essential loads connected to it. Excess load is determined by monitoring the generator supply frequency. If the frequency drops below 58 Hz for more than three (3) seconds, or below 50 Hz for 1/2 second, the generator is considered to have excess load on it. When this happens, non-essential customer loads are disconnected. The non-essential loads are supplied via the load shed switch (LSS) and the LSS is actuated to disconnect these loads.

The non-essential loads are reconnected in one of three ways; Utility voltage is restored and ATS transfers all load back to the Utility supply, manual operation of LOAD SHED RESET push-button on the outside of the enclosure or, automatic operation setup on the DIP switches on the LSC.

For manual operation, set DIP switch #6 to the ON position. If the generator output is overloaded and the non-essential loads are disconnected, press the LOAD SHED RESET push-button to reconnect the non-essential loads to the generator. If the overload condition still exists the LSC will turn the non-essential loads off.

For automatic operation, the number of attempts to reconnect the non-essential loads can be selected. The two choices are one-shot or repeated. The time interval before each attempt is set on DIP switches 1-4. For “one-shot” operation mode set DIP switch #5 to ON. Reconnection of the non-essential loads will occur one time, after the time set on DIP switches 1-4. If DIP switch #5 is OFF, the LSC will attempt to reconnect the non-essential loads after the time interval set on DIP switches 1-4. If the overload still exists or comes back, the LSC and LSS will disconnect non-essential loads and the timer and the attempt to reconnect non-essential loads will be repeated.

DIP switch number	Function
1	Selects a 5 minute reconnection time
2	Selects a 15 minute reconnection time
3	Selects a 30 minute reconnection time
4	Selects a 60 minute reconnection time
1-4 all OFF	Selects a 1 minute reconnection time
5	Selects one-shot mode
6	Selects manual reconnect only
7	Selects 50 Hz units
8	Not used

### ◆ 1.2.4 BATTERY CHARGER

The POWER MANAGER LTS transfer switch is provided with a battery charger (item #44 on #0G8659 assembly drawing) for charging of the engine generator 12 Vdc battery. The battery charger is powered from the load side of the transfer switch (line to neutral – 120V) and is protected by a 2A fuse on the LSC pcb. The battery charger will charge the battery at all times.

## 1.3 TRANSFER SWITCH DATA DECAL

A DATA DECAL is permanently affixed to the transfer switch enclosure. Use this transfer switch only with the specific limits shown on the DATA DECAL and on other decals and labels that may be affixed to the switch. This will prevent damage to equipment and property.

When requesting information or ordering parts for this equipment, make sure to include all information from the DATA DECAL.

Record the Model and Serial numbers in the space provided below for future reference.

MODEL #
SERIAL #

## 1.4 TRANSFER SWITCH ENCLOSURE

The standard switch enclosure is a National Electrical Manufacturer’s Association (NEMA) 3R, UL listed. NEMA 3R type enclosures primarily provide a degree of protection against falling rain and sleet and is undamaged by the formation of ice on the enclosure.



### 1.5 SAFE USE OF TRANSFER SWITCH

Before installing, operating or servicing this equipment, read the SAFETY RULES (inside front cover) carefully. Comply strictly with all SAFETY RULES to prevent accidents and/or damage to the equipment. The manufacturer recommends that a copy of the SAFETY RULES are posted near the transfer switch. Also, be sure to read all instructions and information found on tags, labels and decals affixed to the equipment.

Three publications that outline the safe use of transfer switches are the following:

- NFPA 70; National Electrical Code
- NFPA 70E; Standard for Electrical Safety in the Workplace
- UL 1008, STANDARD FOR SAFETY-AUTOMATIC TRANSFER SWITCHES

**NOTE:**

**It is essential to use the latest version of any standard to ensure correct and current information.**

### 2.1 INTRODUCTION TO INSTALLATION

This equipment has been wired and tested at the factory. Installing the switch includes the following procedures:

- Mounting the enclosure.
- Connecting power source and load leads.
- Connecting non-essential loads.
- Connecting "Critical Load" branch circuits to the internal load center.
- Connecting the utility sensing and transfer relay circuits to the generator control panel.
- Connecting any auxiliary contact (if needed)
- Testing functions.

### 2.2 UNPACKING

Carefully unpack the transfer switch. Inspect closely for any damage that might have occurred during shipment. The purchaser must file with the carrier any claims for loss or damage incurred while in transit.

Check that all packing material is completely removed from the switch prior to installation.

### 2.3 MOUNTING

Mounting dimensions for the transfer switch enclosure are in this manual. Enclosures are typically wall-mounted. See "Installation Diagram".



**Handle transfer switches carefully when installing. Do not drop the switch. Protect the switch against impact at all times, and against construction grit and metal chips. Never install a transfer switch that has been damaged.**

This transfer switch is mounted in a NEMA 3R aluminum enclosure. It can be mounted outside or inside and should be based on the layout of installation, convenience and proximity to the utility supply and load center.

Install the transfer switch as close as possible to the electrical loads that are to be connected to it. Mount the switch vertically to a rigid supporting structure. To prevent switch distortion, level all mounting points. If necessary, use washers behind mounting holes to level the unit.

### 2.4 CONNECTING POWER SOURCE AND LOAD LINES



**Make sure to turn OFF both the UTILITY (NORMAL) and GENERATOR (STANDBY) power supplies before trying to connect power source and load lines to the transfer switch. Supply voltages are extremely high and dangerous. Contact with such high voltage power supply lines causes extremely hazardous, possibly lethal, electrical shock.**

Wiring diagrams and electrical schematics are provided in this manual.

**NOTE:**

**All installations must comply with national, state and local codes. It is the responsibility of the installer to perform an installation that will pass the final electrical inspection.**

Conductor sizes must be adequate to handle the maximum current to which they will be subjected, based on the 75°C column of tables, charts, etc. used to size conductors. The installation must comply fully with all applicable codes, standards and regulations.

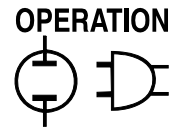

Before connecting wiring cables to terminals, remove any surface oxides from the cable ends with a wire brush. All power cables must enter the enclosure through the knockouts provided. This is necessary to maintain the NEMA/UL type 3 rating. If mounted indoors, conduits can enter the enclosure above the knockouts. If not using the knockouts, entry must be at or below knockouts.

If ALUMINUM conductors are used, apply corrosion inhibitor to conductors. Tighten terminal lugs to the torque values as noted on the "Utility Service Disconnect Circuit Breaker", and on the decal located on the inside of the door. After tightening terminal lugs, carefully wipe away any excess corrosion inhibitor.



**Use a torque wrench to tighten the conductors, being sure not to overtighten, or damage to the insulating base could occur. If not tightened enough, a loose connection would result, causing excess heat which could damage the switch base.**

Connect power source load conductors to clearly marked transfer mechanism terminal lugs as follows

1. Connect UTILITY (NORMAL) power source cables to the top of the UTILITY SERVICE DISCONNECT circuit breaker.
2. Connect GENERATOR (STANDBY) source power cables to ATS GENERATOR supply terminals, E1-E2.
3. Connect non-essential customer LOAD leads to LSS switch terminals E1, E2.
4. Connect critical customer loads to the circuit breakers on the load center provided.

Conductors must be properly supported, of approved insulative qualities, protected by approved conduit, and of the correct wire gauge size in accordance with applicable codes.

Be sure to maintain proper electrical clearance between live metal parts and grounded metal. Allow at least 1/2 inch for 100-400 amp circuits.

## 2.5 NEUTRAL CONNECTIONS

The main neutral block is provided for the connection of the neutral (ungrounded conductors) of the Utility, Generator and non-essential load neutrals. Tighten all wires to the specified torque. Torque values are given on the information decal located on the inside cover.

The main neutral block is connected (bonded) to the enclosure metal by a busbar. If bonding of the neutral is not necessary, the jumper can be removed. When the jumper bar is removed the control wires should be connected as follows:

- #00 wire to the neutral block.
- GRD wire to the enclosure.

The essential load neutrals are to be connected on the busbars mounted on the load center, next to the branch circuit breakers.

## 2.6 CONNECTING CONTROL WIRES

Control system interconnections consist of N1 and N2, and leads 0, 15B and 23. Control system interconnection leads can be run in the same conduit as the AC power lead if the conduit length is less than 35 feet, and ALL of the wiring is rated for 600V. If the conduit length between the generator and PowerManager LTS is more than 35 feet, the control and power leads must be routed in separate conduits. Recommended wire gauge sizes for this wiring depends on the length of the wire, as recommended in the following chart:

MAXIMUM WIRE RUN LENGTH	RECOMMENDED WIRE SIZE
35 feet (10.67m)	No. 16 AWG.
60 feet (18.29m)	No. 14 AWG.
90 feet (27.43m)	No. 12 AWG.

## 3.1 FUNCTIONAL TESTS AND ADJUSTMENTS

**Following transfer switch installation and interconnection, inspect the entire installation carefully. A competent, qualified electrician should inspect it. The installation should comply strictly with all applicable codes, standards, and regulations. When absolutely certain the installation is proper and correct, complete a functional test of the system.**



**Perform functional tests in the exact order presented in this manual, or damage could be done to the switch.**

**IMPORTANT:** Before proceeding with functional tests, read and make sure all instructions and information in this section are understood. Also read the information and instructions of labels and decals affixed to the switch. Note any options or accessories that might be installed and review their operation.

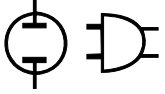

### 3.2 MANUAL OPERATION



⚠ Do NOT manually transfer under load. Disconnect transfer switch from all power sources by approved means, such as the main circuit breaker(s).

#### ◆ 3.2.1 ATS MANUAL OPERATION

A manual HANDLE is shipped with the transfer switch. Manual operation must be checked BEFORE the transfer switch is operated electrically. To check manual operation, proceed as follows (Figure 3.1):

1. Turn the generator's AUTO/OFF/MANUAL switch to OFF.
  2. Turn OFF UTILITY SERVICE DISCONNECT circuit breaker.
  3. Note position of transfer mechanism main contacts by observing the moveable contact carrier arm. This can be viewed through the long narrow slot in the inside cover of the ATS. The top of the moveable contact carrier arm is yellow to be easily identified.
- Manual operation handle in the UP position - LOAD terminals (T1, T2) are connected to UTILITY terminals (N1, N2).

- Manual operation handle in the DOWN position - LOAD terminals (T1, T2) are connected to EMERGENCY terminals (E1, E2).

#### ◆ 3.2.2 LSS MANUAL OPERATION

A manual HANDLE is shipped with the transfer switch. Manual operation must be checked BEFORE the LSS is operated electrically. To check manual operation, proceed as follows (Figure 3.2):

1. Turn the generator's AUTO/OFF/MANUAL switch to OFF.
  2. Turn OFF UTILITY SERVICE DISCONNECT circuit breaker.
  3. Note position of non-essential LSS main contacts by observing the moveable contact carrier arm. This can be viewed through the long narrow slot in the inside cover of the ATS. The top of the moveable contact carrier arm is yellow to be easily identified.
- Manual operation handle in the UP position - non-essential loads OFF.
  - Manual operation handle in the DOWN position - non-essential loads ON.



⚠ Do not use excessive force when operating the transfer switch manually or damage could be done to the manual handle.

Figure 3.1 — Actuating ATS Transfer Switch

Attach handle to the moveable contact carrier arm.



Move handle UP for the UTILITY (NORMAL) position.



Move handle DOWN for the GENERATOR (STANDBY) position.



**NOTE:** Return handle to storage position in enclosure when finished with manual transfer.



Figure 3.2 — Actuating LSS Transfer Switch

Attach handle to the moveable contact carrier arm.

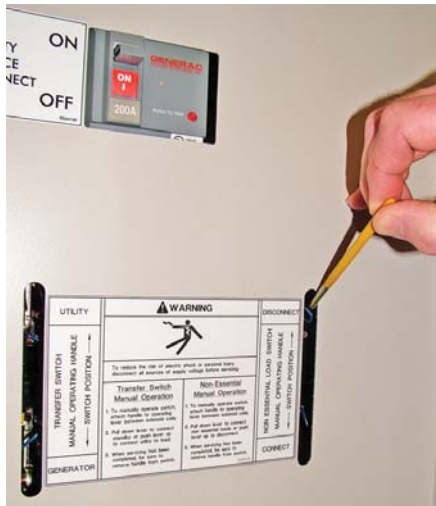

Move handle UP for the non-essential loads OFF.



Move handle DOWN for the non-essential loads ON.



**NOTE:** Return handle to storage position in enclosure when finished with manual transfer.

### ◆ 3.2.3 CLOSE TO UTILITY SOURCE SIDE

Before proceeding, verify the position of the switch by observing the position of manual operation handle in Figure 3.1. If the handle is UP, the contacts are closed in the UTILITY (NORMAL) position, no further action is required. If the handle is DOWN, proceed with Step 1.

Step 1: With the handle inserted into the moveable contact carrier arm, move handle UP. Be sure to hold on to the handle as it will move quickly after the center of travel.

Step 2: Remove manual operating handle from moveable contact carrier arm. Return handle to storage bracket.

### ◆ 3.2.4 CLOSE TO GENERATOR SOURCE SIDE

Before proceeding, verify the position of the switch by observing the position of the manual operation handle in Figure 3.1. If the handle is DOWN, the contacts are closed in the GENERATOR (STANDBY) position. No further action is required. If the handle is UP, proceed with Step 1.

Step 1: With the handle inserted into the moveable contact carrier arm, move the handle DOWN. Be sure to hold on to the handle as it will move quickly after the center of travel.

Step 2: Remove manual operating handle from moveable contact carrier arm. Return handle to storage bracket.

### ◆ 3.2.5 RETURN TO UTILITY SOURCE SIDE

Step 1: Manually actuate switch to return manual operating handle to the UP position.

Step 2: Remove manual operating handle from moveable contact carrier arm. Return handle to storage bracket.

## 3.3 VOLTAGE CHECKS

1. Turn ON the UTILITY power supply to the PowerManager LTS using the UTILITY SERVICE DISCONNECT circuit breaker.

—▲ **DANGER** ▲—

⚠ **PROCEED WITH CAUTION. THE TRANSFER SWITCH IS NOW ELECTRICALLY HOT. CONTACT WITH LIVE TERMINALS RESULTS IN EXTREMELY HAZARDOUS AND POSSIBLY FATAL ELECTRICAL SHOCK.**

2. With an accurate AC voltmeter, check for correct voltage. Measure across ATS terminal lugs N1 and N2. Also check N1 to NEUTRAL and N2 to NEUTRAL.
3. When certain that UTILITY supply voltage is correct and compatible with transfer switch ratings, turn OFF the UTILITY supply to the transfer switch.
4. On the generator panel, set the AUTO/OFF/MANUAL switch to MANUAL position. The generator should crank and start.

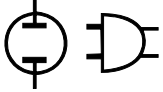

The voltage measurements should be as follows:

N1 - N2	240 VAC Nominal
N1 - Neutral	120 VAC Nominal
N2 - Neutral	120 VAC Nominal

5. Let the generator stabilize and warm up at no-load for at least five minutes.
6. Set the generator's main circuit breaker (CB1) to its ON or CLOSED position.



**⚠ PROCEED WITH CAUTION. GENERATOR OUTPUT VOLTAGE IS NOW BEING DELIVERED TO TRANSFER SWITCH TERMINALS. CONTACT WITH LIVE TERMINALS RESULTS IN EXTREMELY DANGEROUS AND POSSIBLY FATAL ELECTRICAL SHOCK.**

7. With an accurate AC voltmeter and frequency meter, check the no-load, voltage and frequency. Measure across ATS terminal lugs E1 to E2. Also check E1 to NEUTRAL and E2 to NEUTRAL.
  - a. Frequency .....60-62 Hertz
  - b. Terminals E1 to E2.....240-246 VAC
  - c. Terminals E1 to NEUTRAL.....120-123 VAC
  - d. Terminals E2 to NEUTRAL.....120-123 VAC
8. Set the generator's main circuit breaker (CB1) to its OFF or OPEN position.
9. Set the AUTO/OFF/MANUAL switch to the OFF position to shut down the generator.

**NOTE:**

**Do NOT proceed until generator AC output voltage and frequency are correct and within stated limits. If the no-load voltage is correct but no-load frequency is incorrect, the engine governed speed may require adjustment. If no-load frequency is correct but voltage is not, the voltage regulator may require adjustment.**

### 3.4 GENERATOR TESTS UNDER LOAD

#### ◆ 3.4.1 ATS & CRITICAL LOADS

1. Set the generator's main circuit breaker to its OFF or OPEN position.
2. Set the UTILITY SERVICE DISCONNECT circuit breaker to the OFF position.
3. Manually actuate the transfer switch main contacts to their GENERATOR (STANDBY) position. Refer to "Manual Operation".
4. Manually actuate the LSS main contacts to the UP position. Non-essential loads OFF.
5. To start the generator, set the AUTO/OFF/MANUAL switch to MANUAL. When engine starts, let it stabilize for a few minutes.
6. Turn the generator's main circuit breaker to its ON or CLOSED position. The generator now powers all LOAD circuits. Check generator operation under load as follows:
  - Turn ON electrical loads to the full rated wattage/ampere capacity of the generator. DO NOT OVERLOAD.
  - With maximum rated load applied, check voltage and frequency across transfer switch terminals E1 and E2. Voltage should be greater than 230VAC and frequency should be greater than 59 Hertz.
  - Let the generator run under rated load for at least 30 minutes. With unit running, listen for unusual noises, vibration, overheating, etc., that might indicate a problem.
7. When checkout under load is complete, set main circuit breaker of the generator to its OFF or OPEN position.
8. Let the generator run at no-load for several minutes. Then, shut down by setting the AUTO/OFF/MANUAL switch to its OFF position.
9. Move the switch's main contacts back to their UTILITY position. For example, LOAD connected to UTILITY power supply. Refer to "Manual Operation". Handle and operating lever of transfer switch should be in UP position.
10. Turn on the UTILITY power supply to transfer switch, using the UTILITY SERVICE DISCONNECT circuit breaker. The utility power source now powers the loads.
11. Set the generator's AUTO/OFF/MANUAL switch to its AUTO position.

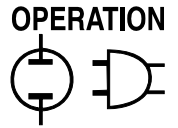

### ◆ 3.4.2 LOAD SHED FUNCTIONAL TEST

1. Set the generator's main circuit breaker to its OFF or OPEN position.
2. Set the UTILITY SERVICE DISCONNECT circuit breaker to the OFF position.
3. Manually actuate the transfer switch main contacts to the GENERATOR position. Refer to "Manual Operation" section of this manual.
4. Manually actuate the LSS main contacts to the DOWN position. Non-essential loads ON.
5. To start the generator, set the AUTO/OFF/MANUAL switch to MANUAL. When engine starts, let it stabilize for a few minutes.
6. Turn the generator's main circuit breaker its ON position. The generator now powers all LOAD circuits. Check generator operation under load as follows:
  - Turn ON electrical loads to the full rated wattage/ amperage capacity of the generator.
  - Increase the load to slightly overload the generator (load to draw frequency down 55-56 hz). This will require turning loads on that are connected to the LSS. Do not severely overload the generator.
  - The LSS should actuate after three (3) seconds to disconnect the non-essential loads. The door mounted LOAD SHED LED should be ON.
  - Decrease the electrical load on the generator to allow the generator frequency to increase to 60 Hz.
7. The next step will depend on how the LSC is set up (see the "Load Shed Controller" section). If set up for:
  - **Manual Operation** — Press the door mounted LOAD SHED RESET button. The LSS will reconnect non-essential loads.
  - **Automatic Operation** — The LSS will reconnect non-essential loads after the delay time setup on the DIP switches of the LSC.
8. Turn ON the UTILITY power supply to the transfer switch using the UTILITY SERVICE DISCONNECT circuit breaker. After the return to utility time delay, the utility power source will power the loads.
9. Set the generator's AUTO/OFF/MANUAL switch to the AUTO position.

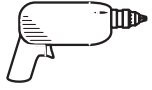

Section 4 – Installation Diagrams

RTSS Type Transfer Switch

Load Shed Interconnection - Drawing No. 0G8774-B

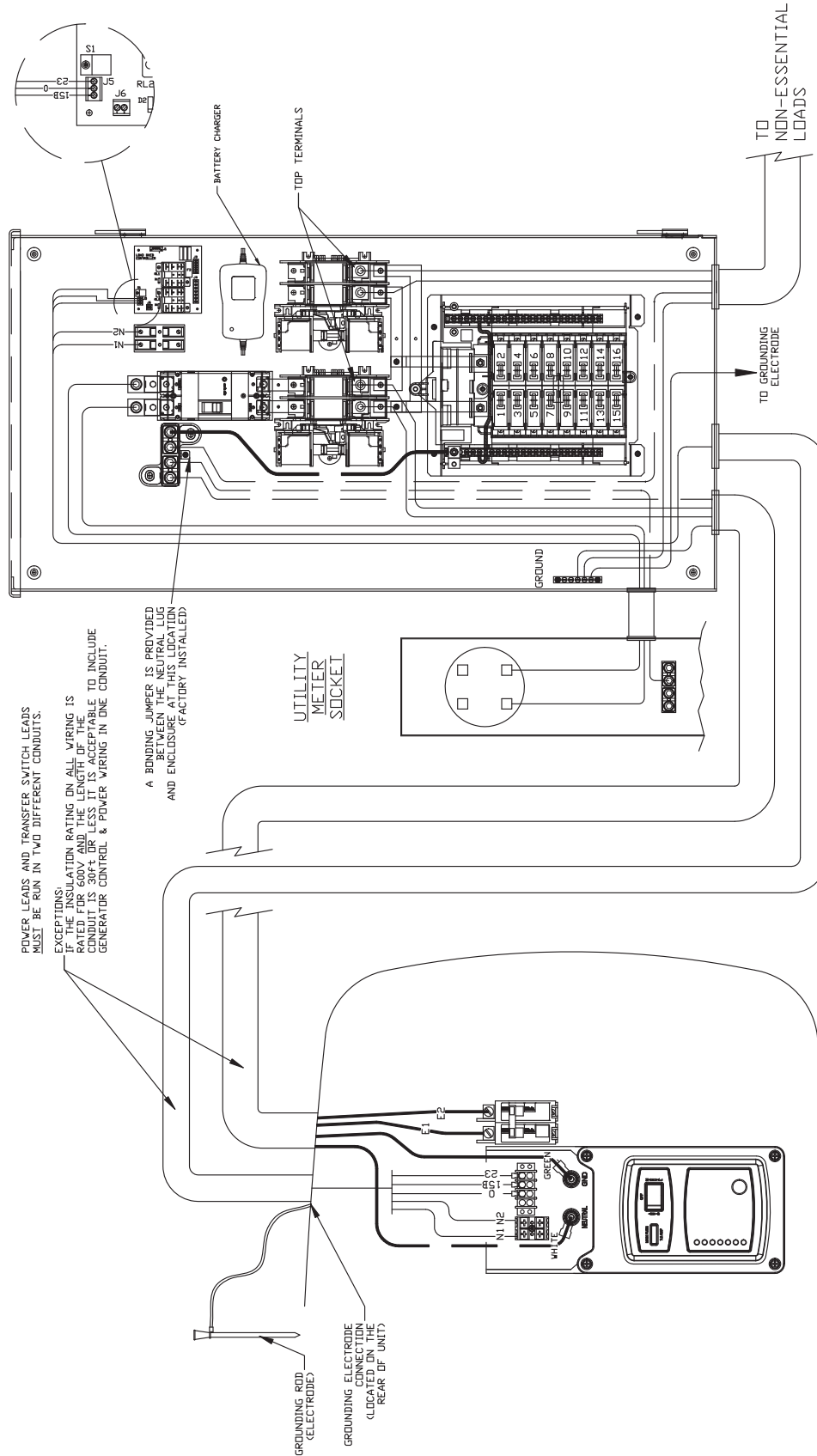

2008 AND LATER AIR-COOLED HSB GENERATORS

**Section 4 – Installation Diagrams**  
**RTSS Type Transfer Switch**  
**200 Amp Load Shed Enclosure - Drawing No. 0G8775-B**

**INSTALLATION**

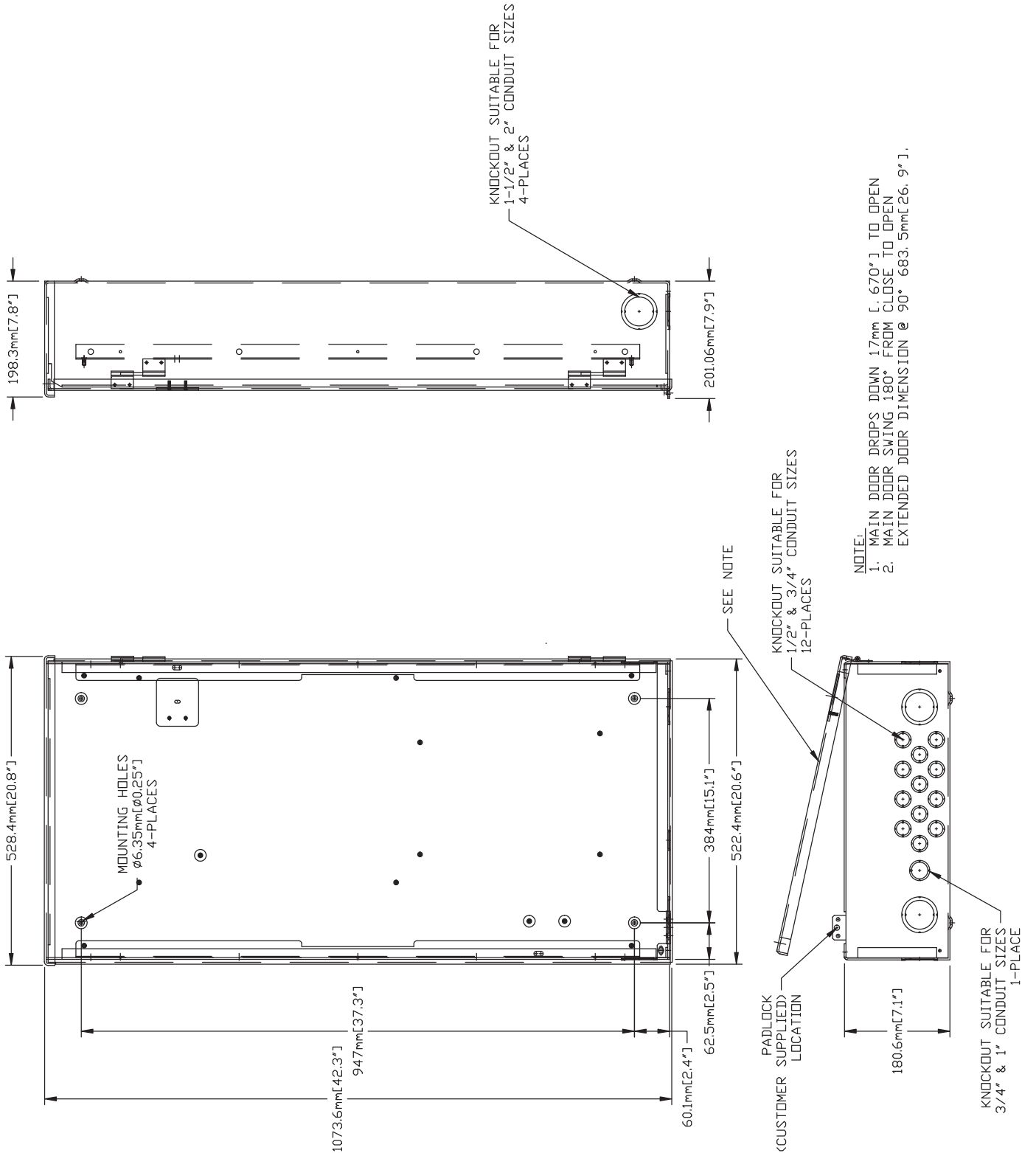

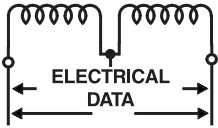

**Section 5 – Electrical Data**

**RTSS Type Transfer Switch**

**Electrical Schematic - Drawing No. 0G7816-A**

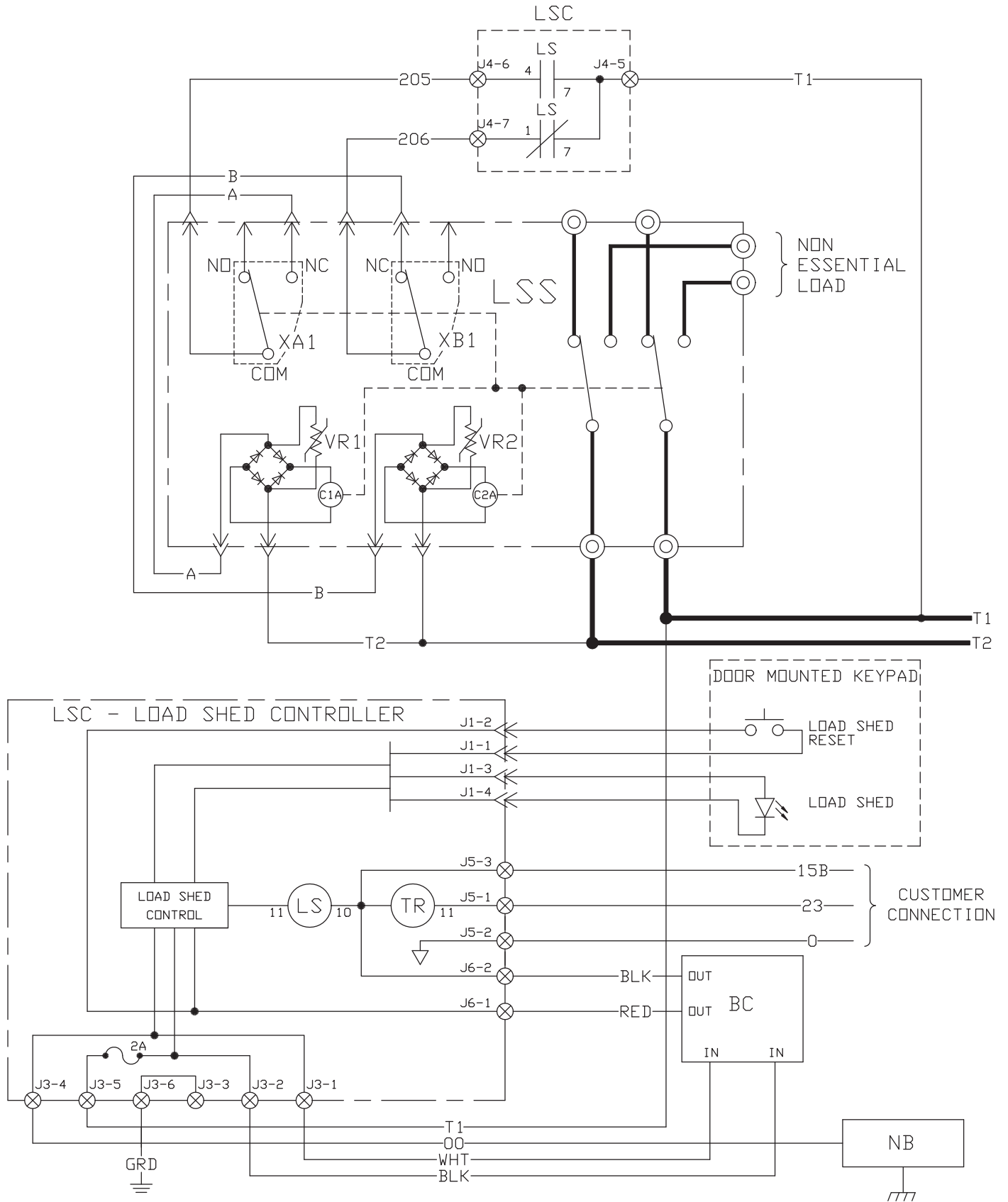

Section 5 – Electrical Data

RTSS Type Transfer Switch

Electrical Schematic - Drawing No. 0G7816-A

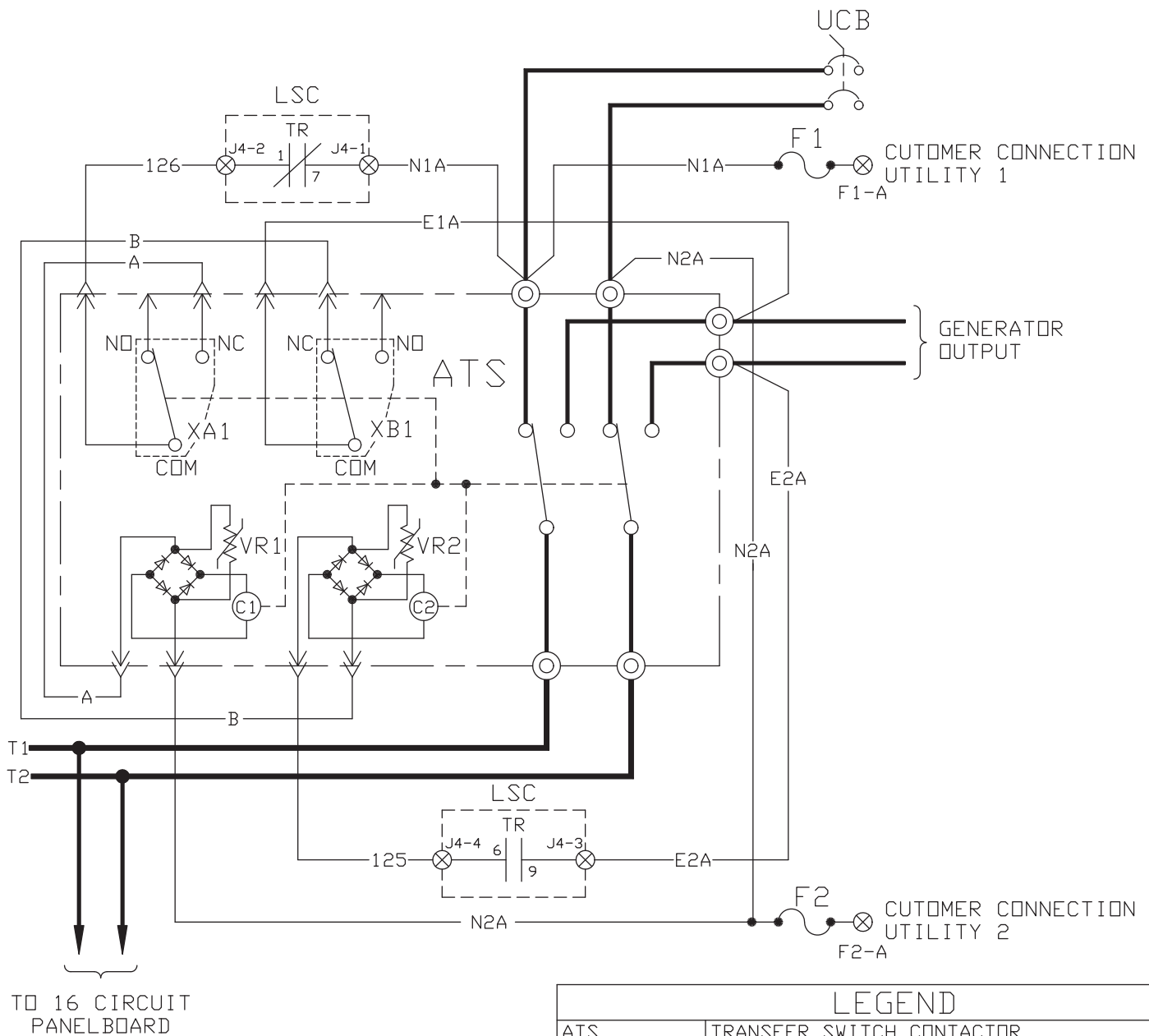
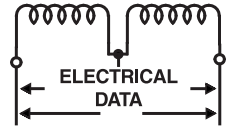

LEGEND

ATS	TRANSFER SWITCH CONTACTOR
BC	BATTERY CHARGER
C1	SOLENOID COIL (UTILITY CLOSING)
C2	SOLENOID COIL (STANDBY CLOSING)
C1A	SOLENOID COIL (LSS-OFF)
C2A	SOLENOID COIL (LSS-ON)
F1, F2	FUSE, 5A
LS	RELAY, LOAD SHED
LSC	LOAD SHED CONTROLLER
LSS	LOAD SHED TRANSFER SWITCH CONTACTOR
NB	NB - NEUTRAL BLOCK
TR	RELAY, TRANSFER
UCB	UTILITY CIRCUIT BREAKER
VR1, VR2	VARISTOR
XA1, XB1	LIMIT SWITCHES, ACTUATOR

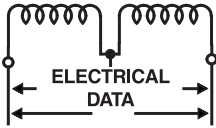

**Section 5 – Electrical Data**

**RTSS Type Transfer Switch**

**Wiring Diagram - Drawing No. 0G7817-A**

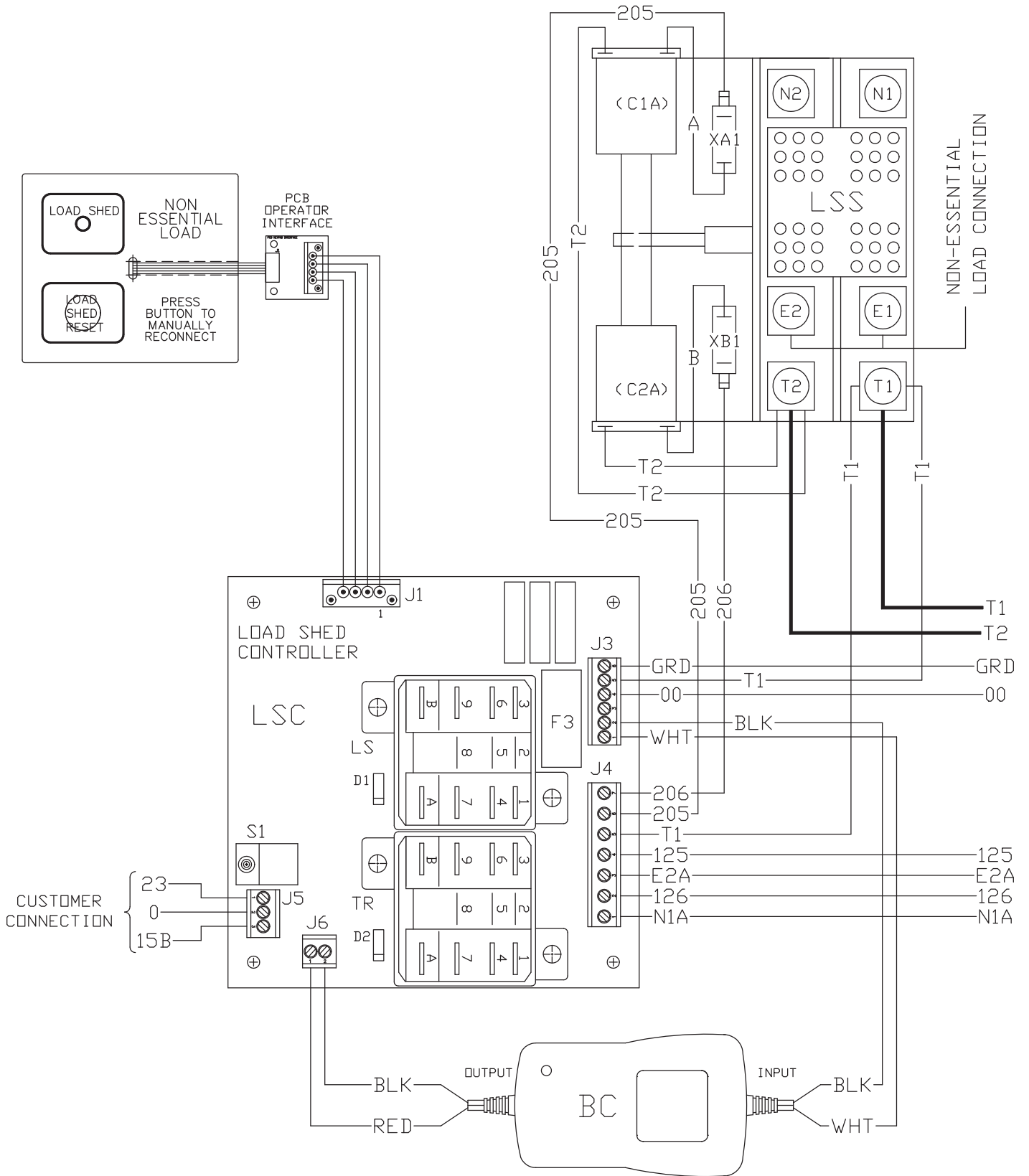



**Section 5 – Electrical Data**  
**RTSS Type Transfer Switch**  
**Wiring Diagram - Drawing No. 0G7817-A**

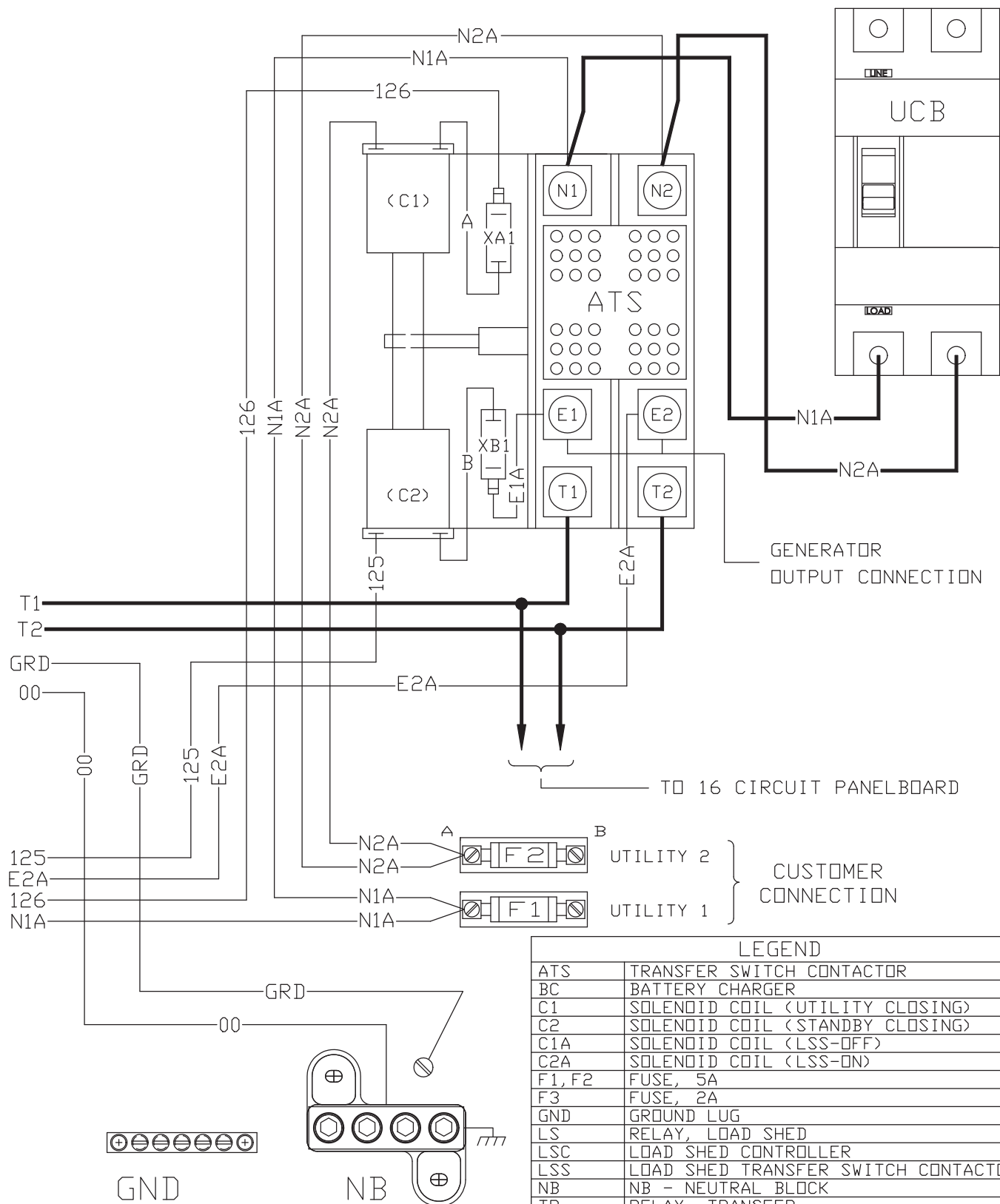
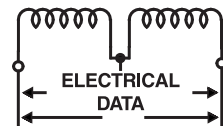

**LEGEND**

ATS	TRANSFER SWITCH CONTACTOR
BC	BATTERY CHARGER
C1	SOLENOID COIL (UTILITY CLOSING)
C2	SOLENOID COIL (STANDBY CLOSING)
C1A	SOLENOID COIL (LSS-OFF)
C2A	SOLENOID COIL (LSS-ON)
F1, F2	FUSE, 5A
F3	FUSE, 2A
GND	GROUND LUG
LS	RELAY, LOAD SHED
LSC	LOAD SHED CONTROLLER
LSS	LOAD SHED TRANSFER SWITCH CONTACTOR
NB	NB - NEUTRAL BLOCK
TR	RELAY, TRANSFER
UCB	UTILITY CIRCUIT BREAKER
XA1, XB1	LIMIT SWITCHES, ACTUATOR





**Section 6 – Exploded Views and Parts List**

**RTSS Type Transfer Switch**

**200A Load Shed Transfer Switch Assembly – Drawing No. 0G8659\$-A**

Parts List on page 19.

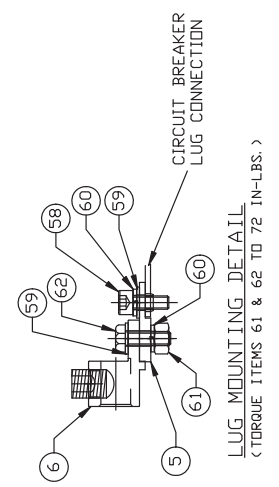
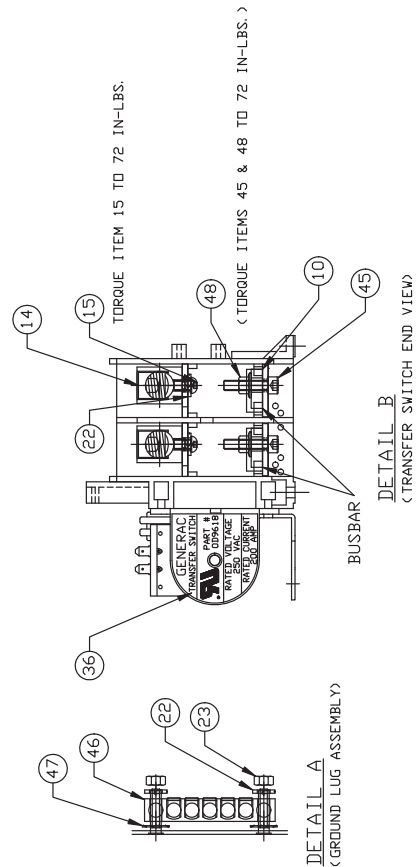
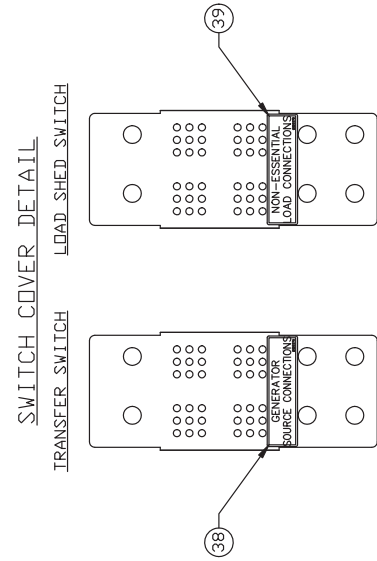
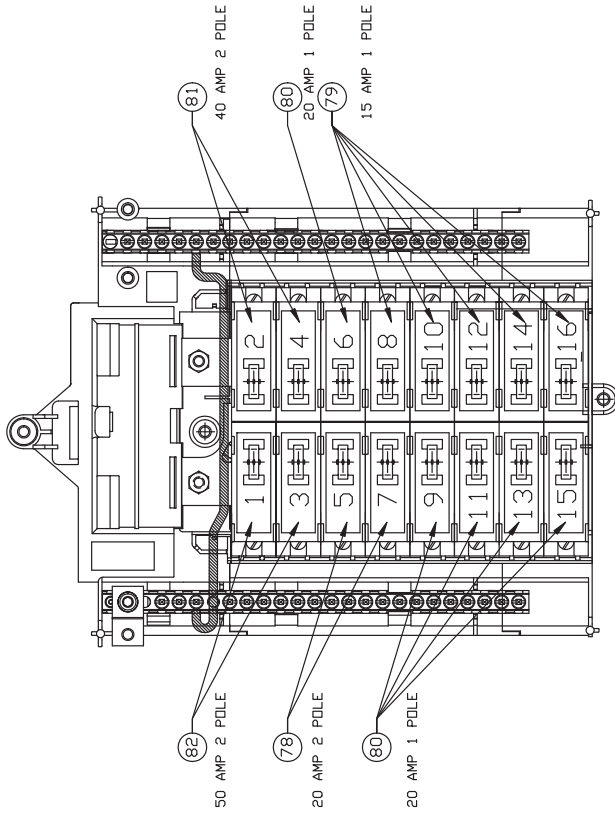

## Section 6 – Exploded Views and Parts List

### RTSS Type Transfer Switch

#### 200A Load Shed Transfer Switch Assembly – Drawing No. 0G8659\$-A

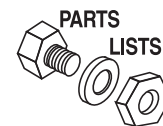

ITEM	PART NO.	QTY.	DESCRIPTION	ITEM	PART NO.	QTY.	DESCRIPTION
1	0D9618	2	TRANSFER SW. HSB 200A 2P 250V	44	0G8783	1	BATTERY CHARGER ASSEMBLY
2	074908	10	SCREW HHTT M5-0.8 X 10 BP	45	0G3976	4	SCREW BHSC 1/4-20 X 3/4
3	0G4478	1	CIRCUIT BREAKER, 200A 2-POLE	46	0G6320	1	GROUND BAR (5) 2-14 AWG CONN
4	053640	2	SCREW RHM #8-32 X 3-1/4	47	026850	2	WASHER SHAKEPROOF EXT 1/4 STL
5	0F8843	2	BUSBAR, 200A LUG ADAPTER	48	0G8411	22	NUT HEX FL WHIZ 1/4-20
6	0F8451	2	LUG 300 MCM-6STR	49	0E6193	1	BRACKET, ARM EXTENDER
7	0G4413	4	SPACER 200 AMP TRANSFER	50	0D6162	2	RIVET POP .156 X .362 AL
8	024334	4	BOLT CARR 1/4-20 X 1"	(1) 51	0E6155	1	ARM EXTENDER PIN
9	0G7847	1	BUSBAR, 200A TRANSFER SW T1	52	0E6303	2	WIRE-A
10	0G7848	1	BUSBAR, 200A TRANSFER SW T2	53	0E6303A	2	WIRE-B
11	0G6352	2	BUSBAR, 200A TRANSFER SW N1,N2	54	0E6303B	1	WIRE E1 3.0"
12	0G8413	2	BUSBAR, PANELBOARD INTERCONNECTION	(2) 55	0D2806	1	FUSEBLOCK 30A 600V 2 POLE
				56	073590A	2	FUSE 5A X BUSS HLDR73591
13	0G6417	1	BUSBAR, NEUTRAL BLOCK	57	0A1495	6	SCREW HHTT M4-0.7 X 10 BP
14	0E3375	4	LUG SOLDERLESS 250-#6 AL/CU	58	049897	4	SCREW SHC M8-1.25 X 20 G8
15	0F1252	4	SCREW BHSC 1/4-20 X 3/8	59	022145	6	WASHER FLAT 5/16-M8 ZINC
16	0G78110AL14	1	ENCLOSURE,LOAD SHED TRANSFER SWITCH	60	022129	6	WASHER LOCK M8-5/16
				61	045771	2	NUT HEX M8-1.25 G8 CLEAR ZINC
17	0G78120GS0R	1	SUBPLATE, PANELBOARD	62	043107	2	SCREW HHC M8-1.25 X 25 C8.8
18	0G78130GS0R	1	SUBPLATE, LOADCENTER	63	026902	5	SCREW HHTT #8-32 X 1/4 CZ
19	0G78140AL14	1	INSIDE COVER LOAD SHED	64	0G8300	1	WIRING HARNESS HSB (NOT SHOWN)
20	0G78150AL14	1	COVER LOAD SHED ENCLOSURE				
21	0G44200AL14	1	CB BRKT 200A TRANSFER SWITCH	65	0E3717A	1	ASSY-NEUT BLK 200-400A W/TAP
22	022097	7	WASHER LOCK M6-1/4	66	090388	2	SCREW HHTT M6-1.0 X 12 MM
23	085889	3	NUT HEX 1/4-20 SS	67	0G8145	1	KEYPAD, LOAD SHED
24	0G8575A	REF.	DECAL,LOAD SHED DATA 200A	68	0G8242	1	ASSY PCB INTFC LOAD SHED
	0G8575B	REF.	DECAL,LOAD SHED DATA 200A				KEYPD
25	0G8341	1	DECAL, WARN MANUAL OPER HANDLE	69	0C6748	2	NUT HEX LOCK M4-0.7 SS NYL INS
				70	0F4460	2	SPACER M4/#8 X 5/16 X 1/4 NYL
26	0F9205A	1	DECAL, FRT GTS LD CTR 16 CIR GRY	71	0G8412	1	CABLE, KEYPAD INTERFACE
				72	0G8534	1	NEUTRAL WIRE
27	0G4220	1	DECAL, NEUTRAL CONNECTION	73	0G7925	1	ASSY PCB 2008HSB LOAD SHEDCTRL
28	0D3587	1	DECAL, FUSE REPLACEMENT				
29	0G8257	1	DECAL, CUSTOMER CONNECTION	74	027911	2	RELAY SOC 12VDC DPDT 10A@240VA
30	0G8264	1	DECAL, TEST SEQUENCE				
31	067210A	1	DECAL, GROUNDING LUG	75	0D6511	4	SPACER .20 X .375 X .375 PL
32	0G3259	1	DECAL, TERMINAL SHOCK HZD BI	76	0E6423	4	NUT HEX FL WHIZ M5-0.8
33	0E4987	1	DECAL-UL PANELBOARD	77	0G8293	1	16 CIR L/CENTR 200A/240V SIEMS
34	0G8187	1	DECAL POWERMANAGER LTS	78	0E7888	1	CB 0020A 2P PLUG IN
35	0G3274	1	DECAL, LIVE CIRCUIT ENG/FRN/SPN	79	0E7888B	5	CB 0015A 1P PLUG IN
36	0G8535	2	DECAL, TRANSFER SWITCH INFO	80	0E7888C	5	CB 0020A 1P PLUG IN
37	0G8536	1	DECAL, UTILITY SERVICE DISCONNECT	81	0E7888D	1	CB 0040A 2P PLUG IN
				82	0E7888E	1	CB 0050A 2P PLUG IN
38	0G8537A	1	DECAL, GENERATOR SOURCE CONNECTION	(1) 83	0E6034	1	STRAIGHT SPADE CONNECTOR
				84	0F6685	3	TIE-WRAP MOUNT(FIR TREE SYTLE)
39	0G8537B	1	DECAL, NON-ESSENTIAL LOAD CONN	(1) 85	0E6033	1	90 DEGREE DN SPADE CONNECTOR
41	066849	2	SCREW HHTT M5-0.8 X 16				(1) SUPPLIED WITH TRANSFER SWITCH ITEM #1
42	058000E	1	NUT TRIC 1/4-20 X .525				(2) SUPPLIED WITH HARNESS ITEM #64
43	0E7213	1	THUMB SCREW 1/4-20x1/2				





