

# **Air-cooled Generator Battery Charger Installation Guidelines**



**Table of Contents.....Inside Front Cover**

**Section 1 – General Information ..... IFC**

1.1 Introduction..... IFC

1.2 Battery Charger Compatibility ..... 1

    1.2.1 Determination of Generator/Transfer Switch Model Type ..... 1

**Section 2 – Load Shed Transfer Switch Installation .....2**

2.1 Load Shed Transfer Switch (RTSS) Installation ..... 2

    2.1.1 Wiring and Connections at the Transfer Switch..... 2

    2.1.2 Wiring and Connections at the Generator..... 2

    2.1.3 Operational Testing ..... 2

**Section 3 – Standard or Service Entrance Transfer Switch Installation .....3**

3.1 Standard Transfer Switch (RTSN) or (RTSE) Service Entrance Rated Transfer Switch Installation ..... 3

    3.1.1 Wiring and Connections at the Transfer Switch..... 3

    3.1.2 Charger Mounting..... 4

    3.1.3 Wiring and Connections at the Generator..... 5

    3.1.4 Operational Testing ..... 6

**Section 4 – GenReady Installation.....6**

4.1.1 Wiring and Connections at the Transfer Switch..... 6

4.1.2 Charger Mounting..... 7

4.1.3 Wiring and Connections at the Generator..... 7

4.1.4 Operational Testing ..... 8

**Section 5 – Interconnection Diagrams.....9**

**Section 6 – Notes .....16**

## 1.1 INTRODUCTION

This battery charger supplies a trickle charging current and voltage to maintain the charge on the generator starting battery inside the generator enclosure. The charger will not replenish a fully discharged battery. It is intended to be connected to a 120VAC generator backed-up circuit only. If it is not connected to a generator backed-up circuit the battery could go “dead” while the generator is running for extended periods of time.

**Figure 1.1 — Charger as Supplied Indicating Input and Output Wiring**

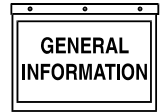


⚠ This battery charger must be properly installed and wired for correct operation of all 2008 model line Air-cooled Standby Generators. Failure to do so will result in a dead battery condition at the generator.

**NOTE:**

This installation guide should be used in conjunction with the “Installation and Owner’s Manual” that is furnished with the Air-cooled Standby Generator and the Installation and appropriate transfer switch manual. Please review all manuals prior to installation of the generator and transfer switch. This battery charger is not required with the Liquid-cooled Generator product line. This battery charger is not required for Air-cooled Standby Generators prior to the 2008 model line. This unit is not compatible with other generator manufacturer’s products.

**For authorized service, reference the dealer locator number found in the generator owner’s manual or on the generator.**



These Installation Guidelines are designed to familiarize personnel with the installation process for the battery charger required for the air-cooled generator only. It does not replace or supersede any information contained in any of the written documents shipped with the unit. This booklet should only be used in conjunction with the Owner's Manual, Installation Guide and other technical documents shipped with the unit.

Future product updates and/or modifications will be reflected in the written documentation included with the equipment. Always read all accompanying documentation carefully before attempting to install any generator, transfer switch or related equipment.

**NOTE:**

**It is essential to comply with all regulations established by the Occupational Safety and Health Administration (OSHA) and strict adherence to all local, state and national codes is mandatory.**

**This device should be installed with all local electrical codes and/or the latest edition of the National Electrical Code. All wiring must be the correct size and type, and must conform to local codes, standards, and regulations.**

## 1.2 BATTERY CHARGER COMPATIBILITY

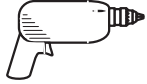
This battery charger is compatible, and required with all 2008 model line Air-cooled Standby Generators. For all generators that were supplied with a transfer switch/load center, the charger is already installed in the transfer switch enclosure and this charger is not needed. For all generators that were NOT supplied with a transfer switch/load center, the charger is NOT already installed and MUST be installed according to these guidelines.

### ◆ 1.2.1 DETERMINATION OF GENERATOR/TRANSFER SWITCH MODEL TYPE

The Battery charger included with this manual only needs to be used with certain transfer switch configurations. Some transfer switch configurations already have the battery charger installed in the transfer switch. Before proceeding it is necessary to select the transfer switch used from the following table.

Switch Type	Switch Description	Notes	Proceed to Section
RTSD	Pre-wire with 8 circuit load center	Battery charger is included and pre-wired with the transfer switch. Discard this charger. No further installation is required	Stop Here
RTSF ST100R10C	Pre-wire with 10 circuit load center	Battery charger is included and pre-wired with the transfer switch. Discard this charger. No further installation is required	Stop Here
RTSH	Pre-wire with 12 circuit load center	Battery charger is included and pre-wired with the transfer switch. Discard this charger. No further installation is required	Stop Here
RTSP ST100R14C	Pre-wire with 14 circuit load center	Battery charger is included and pre-wired with the transfer switch. Discard this charger. No further installation is required	Stop Here
RTSW ST100R16C KGATX0216100	Pre-wire with 16 circuit load center	Battery charger is included and pre-wired with the transfer switch. Discard this charger. No further installation is required	Stop Here
RTSS KGALT0101200 SR200RDPM	Power Manager LTS - Load Shed with 16 circuit load center	Battery charger is included with the transfer switch. Proceed with connections.	2
RTSN SRXXXXR KGATX	Standard	The included battery charger must be installed and connected	3
RTSE SRXXXXRD KGATD	Service Entrance Rated	The included battery charger must be installed and connected	3
005448-0 005449-0 KGATD0101RSP	GenReady	The included battery charger must be installed and connected	4

**NOTE:** Switch Type is the first four (4) digits of the model number and can be found on the data label inside the switch.



## 2.1 LOAD SHED TRANSFER SWITCH (RTSS) INSTALLATION

### ◆ 2.1.1 WIRING AND CONNECTIONS AT THE TRANSFER SWITCH

Connect the 15B, 0, and 23 low voltage control wires to the load shed controller connector J5 per the wiring diagram. Wires should be sized according to the following table.

CHARGER DC OUTPUT (TRANSFER SWITCH TO GENERATOR) WIRE SIZE CHART	
Maximum Wire Run Length	Recommended Wire Size (stranded copper)
35 feet (10.67m)	No. 16 AWG.
60 feet (18.29m)	No. 14 AWG.
90 feet (27.43m)	No. 12 AWG.

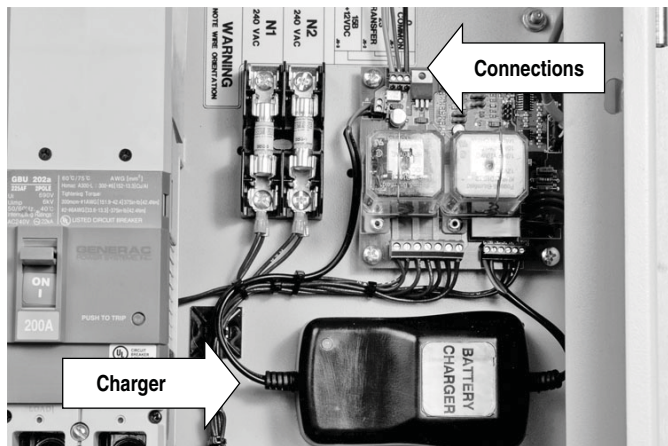
**NOTE:**

The charger is already mounted in the transfer switch (Figure 2.1).

**NOTE:**

See RTSS Installation/Wiring Diagram in the "Interconnection Diagrams" section for connections.

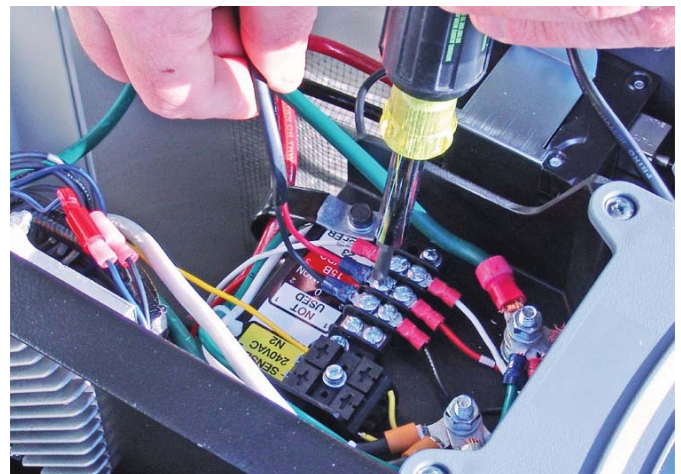
Figure 2.1 — Wiring Connections at the Transfer Switch



### ◆ 2.1.2 WIRING AND CONNECTIONS AT THE GENERATOR

1. Crimp spade lugs onto all three low voltage wires, 15B, 0, and 23 (Purchased or supplied separately).
2. Connect the low voltage wires, 15B, 0, and 23 to the terminal strip on the controller (Figure 2.2).

Figure 2.2 — Connection of Charger DC Output Wires in Generator Control Panel



### ◆ 2.1.3 OPERATIONAL TESTING

1. If already connected, disconnect the battery in the generator. Remove the negative cable first followed by the positive cable. Take care not to short the cables together.
2. Ensure power is applied to the battery charger input.
3. Connect a volt meter across the battery leads. The voltage reading should be between 12.8 VDC and 13.8 VDC (Figure 2.3).

Figure 2.3 — Measurement of Charger Output with Battery Disconnected





4. If the voltage is within range installation of the battery charger is complete. If the voltage is not within range verify all wiring and sizing and retest.
5. Re-connect the battery cables. Positive cable first followed by the negative cable.

3. Run the other side of the fuse holder (120VAC Hot) along with the neutral from the neutral lug to the generator (see Figures 3.1 and 3.5).

**NOTE:**

See the appropriate RTSN or RTSE Installation/Wiring Diagram for connections.

### 3.1 STANDARD TRANSFER SWITCH (RTSN) OR (RTSE) SERVICE ENTRANCE RATED TRANSFER SWITCH INSTALLATION

#### ◆ 3.1.1 WIRING AND CONNECTIONS AT THE TRANSFER SWITCH

Choose the appropriate option.

**NOTE:**

See the appropriate RTSN or RTSE Installation/Wiring Diagram in the "Interconnection Diagrams" section for connections.

##### Option 1 – Protected Load Provided in Load Center

1. Install a 15A breaker in the load center (Purchased or supplied separately). The breaker must be on a generator backed-up circuit or the battery in the generator will not maintain its charge during extended run periods.
2. Run the 120VAC hot wire and neutral wires to the generator.

**NOTE:**

See the appropriate RTSN or RTSE Installation/Wiring Diagram in the "Interconnection Diagrams" section for connections.

##### Option 2 – Protected Load Provided in the RTS, Fuse Block Installation

**NOTE:**

This section is only appropriate for 2008 RTSN or RTSE transfer switches.

1. Mount the optional 5amp 600V fuse and holder in the transfer switch. (Purchased or supplied separately). Pre-2008 transfer switches will not have holes pre-drilled for the fuse holder. In this case, it is necessary to drill holes in the enclosure to mount the fuse holder (see Figures 3.1 and 3.4).
2. Connect one side of the fuse to terminal (T1) of the transfer switch using a spade lug. Pre-2008 transfer switches will not have the spade lug attached to terminal T1. The spade terminal is available separately if required (see Figures 3.2 and 3.4).

Figure 3.1 — RTSN Fuse Block Installation and Neutral Connection

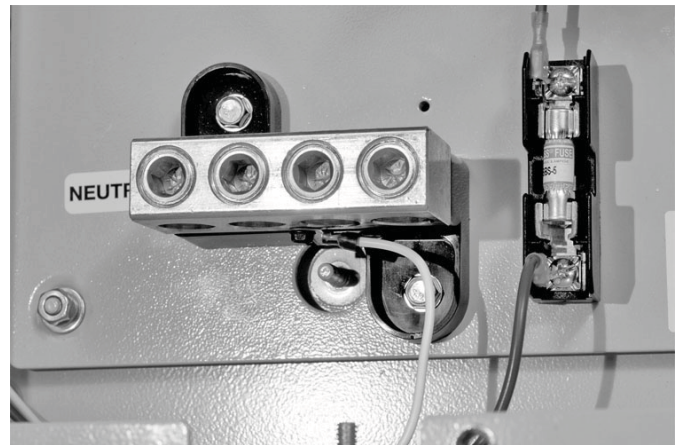
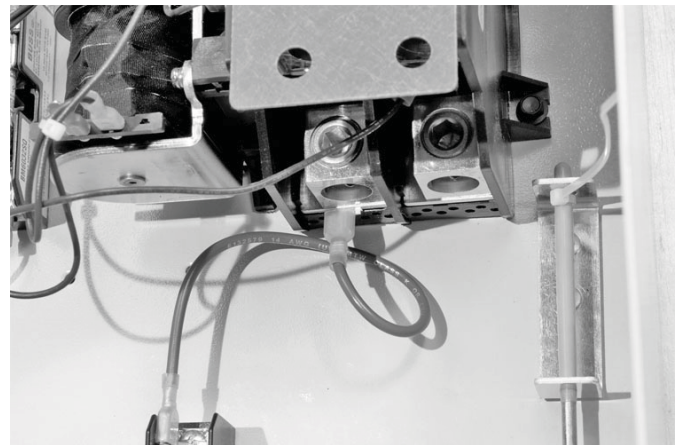
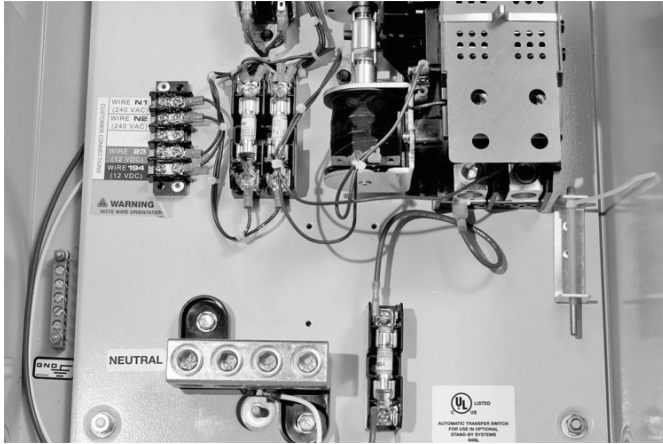


Figure 3.2 — RTSN Fuse Block Installation T1 Connection

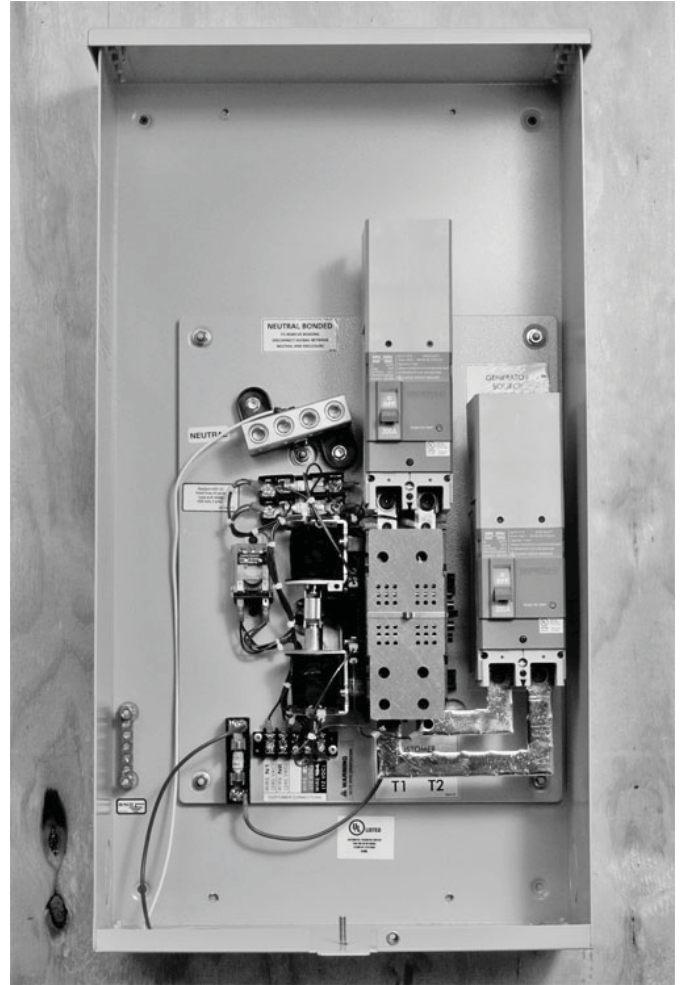




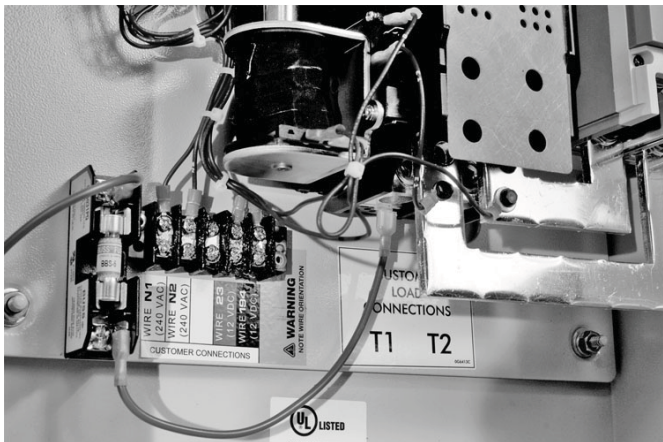
**Figure 3.3 — RTSN Fuse Block Installation When Completed**



**Figure 3.6 — RTSE Fuse Block Installation When Completed**



**Figure 3.4 — RTSE Fuse Block Installation T1 Connection**



**Figure 3.5 — RTSE Neutral Connection**

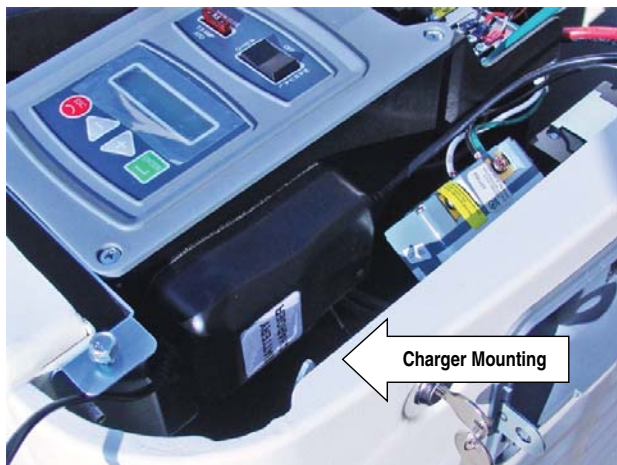


**◆ 3.1.2 CHARGER MOUNTING**

1. Remove the cover over the controller in the generator
2. The battery charger can be located anywhere within the controls area on the generator. It is convenient to mount the charger on the vertical surface on right-hand side of the controller (Figure 3.7).
3. Clean the surface where the charger is to be mounted prior to mounting with a damp cloth and wait for the area to dry.
4. Remove the adhesive covering on the backside of the charger and firmly press the charger into place as shown. Once mounted the charger may be removed for inspection by separating the hook & loop mounting (Figure 3.8).



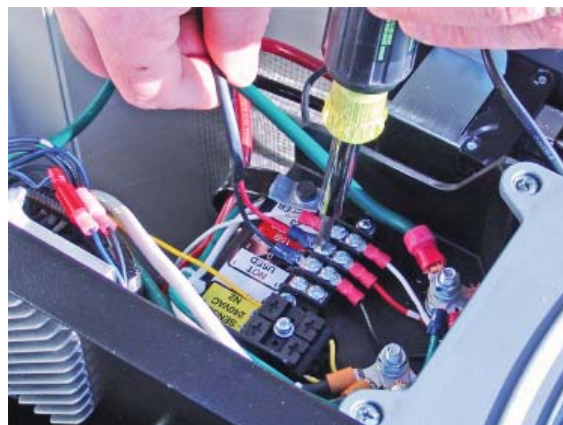
**Figure 3.7 — Mounting Location of Charger in Generator**



**Figure 3.8 — Removal of Adhesive Covering on Hook and Loop for Mounting**

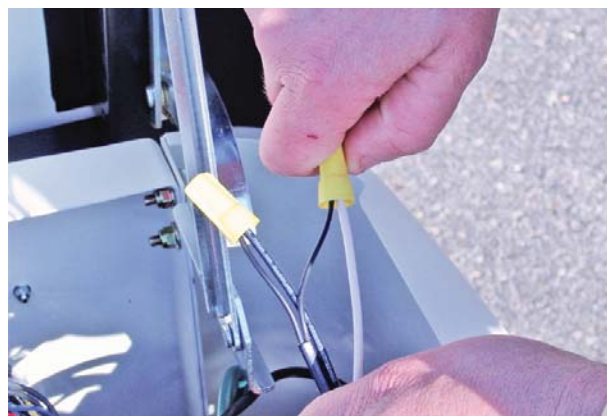


**Figure 3.9 — Connection of Charger DC Output Wires in Generator Control Panel**



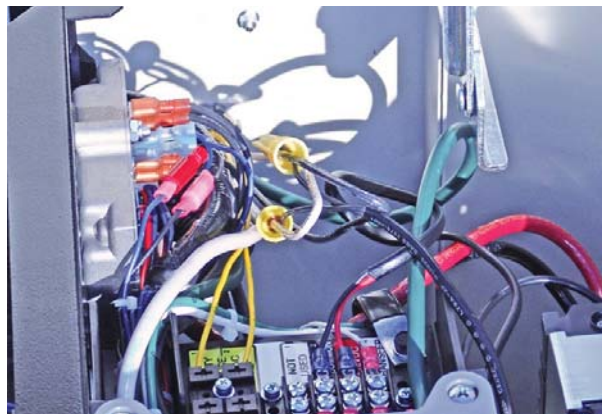
3. Using wire nuts attach the 120VAC input wires from the battery charger to the generator backed-up 120VAC circuit from the transfer switch (Figure 3.10).

**Figure 3.10 — Connection of Charger AC Input Wires in Generator Control Panel**



4. Dress all wires neatly (Figure 3.11).

**Figure 3.11 — Completed Charger Connections on Generator Control Panel**



### ◆ 3.1.3 WIRING AND CONNECTIONS AT THE GENERATOR

1. Identify the DC output wires on the battery charger and crimp spade lugs onto both the positive and negative lead (purchased or supplied separately) (see Figure 1.1).
2. Attach the positive and negative battery charger leads to the terminal strip in the controller. The positive lead is either a red wire or is marked with a (+) or (15B) designation. The negative lead is black and/or marked with a (-) or (0) designation. The positive lead attaches to the terminal labeled "15B". Note that there will be two wires attached to the "15B" terminal when the full installation is completed. One for the battery charger and one for the common connection to the transfer switch. The negative lead attaches to the terminal labeled "0" (Figure 3.9).



**NOTE:**

See the appropriate RTSN or RTSE Installation/Wiring Diagram in the "Interconnection Diagrams" section for connections.

**◆ 3.1.4 OPERATIONAL TESTING**

1. If already connected, disconnect the battery in the generator. Remove the negative cable first followed by the positive cable. Take care not to short the cables together.
2. Ensure power is applied to the battery charger input.
3. Connect a volt meter across the battery leads. The voltage reading should be between 12.8VDC and 13.8VDC (Figure 3.12).
4. If the voltage is within range installation of the battery charger is complete. If the voltage is not within range verify all wiring and sizing and retest.
5. Re-connect the battery cables. Positive cable first followed by the negative cable.

**Figure 3.12 — Measurement of Charger Output with Battery Disconnected**



**4.1 GENREADY INSTALLATION**

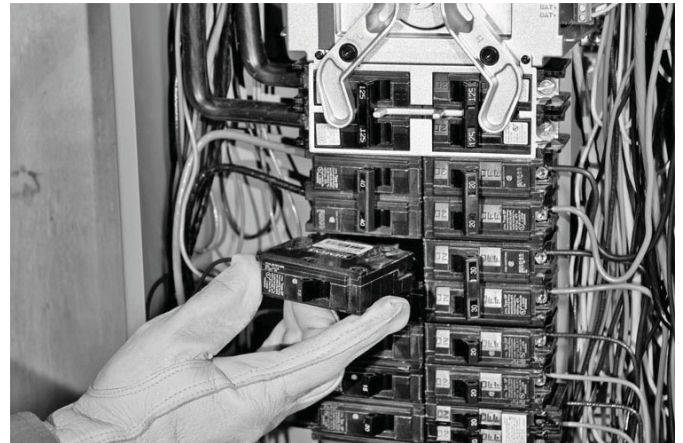
**NOTE:**

See the GenReady Installation/Wiring Diagram in the "Interconnection Diagrams" section for connections.

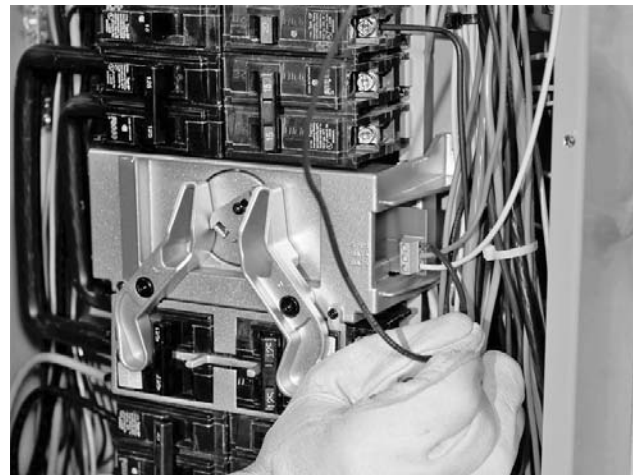
**◆ 4.1.1 WIRING AND CONNECTIONS AT THE TRANSFER SWITCH**

1. Install a 15A breaker in the bottom portion of the load center (Purchased or supplied separately). The breaker must be on a generator backed-up circuit or the battery in the generator will not maintain its charge during extended run periods (Figure 4.1).
2. Run the 120VAC hot wire and neutral wires to the generator.
3. Run the low voltage wires, 15B, 0, and 23 to the generator (Figure 4.2)

**Figure 4.1 — GenReady Breaker Installation for Battery Charger**



**Figure 4.2 — GenReady Charger Connections**

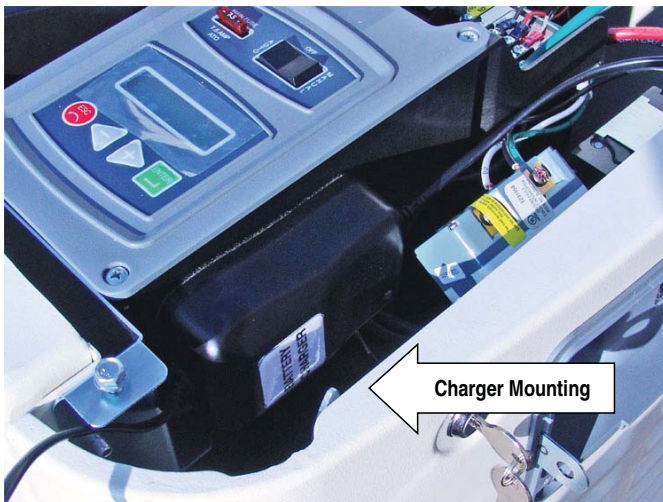




### ◆ 4.1.2 CHARGER MOUNTING

1. Remove the cover over the controller in the generator
2. The battery charger can be located anywhere within the controls area on the generator. It is convenient to mount the charger on the vertical surface on right-hand side of the controller (Figure 4.3).

**Figure 4.3 — Mounting Location of Charger in Generator**



3. Clean the surface where the charger is to be mounted prior to mounting with a damp cloth and wait for the area to dry.
4. Remove the adhesive covering on the backside of the charger and firmly press the charger into place as shown. Once mounted the charger may be removed for inspection by separating the hook & loop mounting (Figure 4.4).

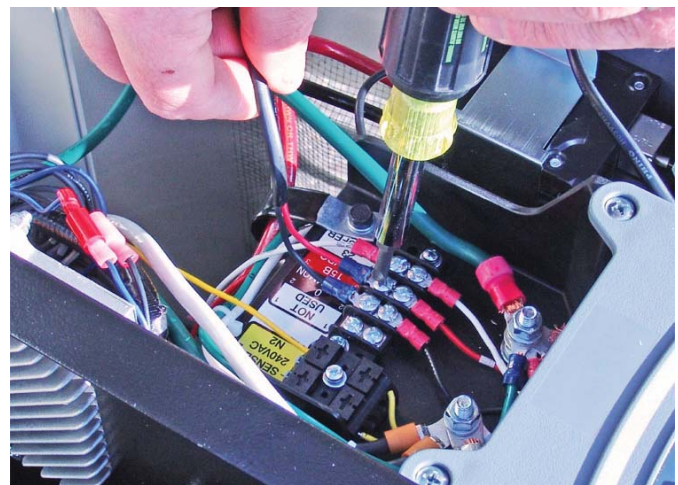
**Figure 4.4 — Removal of Adhesive Covering on Hook and Loop for Mounting**



### ◆ 4.1.3 WIRING AND CONNECTIONS AT THE GENERATOR

1. Identify the DC output wires on the battery charger and crimp spade lugs onto both the positive and negative lead (see Figure 1.1).
2. Attach the positive and negative battery charger leads to the terminal strip in the controller. The positive lead is either a red wire or is marked with a (+) or (15B) designation. The negative lead is black and/or marked with a (-) or (0) designation. The positive lead attaches to the terminal labeled "15B". The negative lead attaches to the terminal labeled "0". Note that there will be two wires attached to both the "0" and the "15B" terminals when the full installation is completed (Figure 4.5).

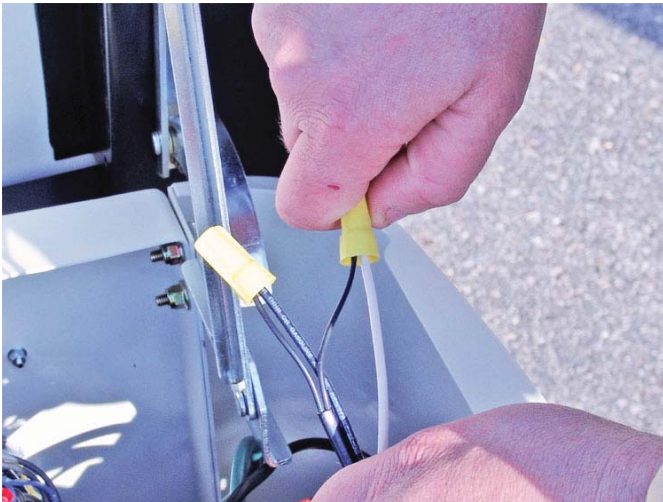
**Figure 4.5 — Connection of Charger DC Output Wires in Generator Control Panel**





- Using wire nuts attach the 120VAC input wires from the battery charger to the generator backed-up 120VAC circuit from the transfer switch (Figure 4.6).

**Figure 4.6 — Connection of charger AC input wires in generator control panel**

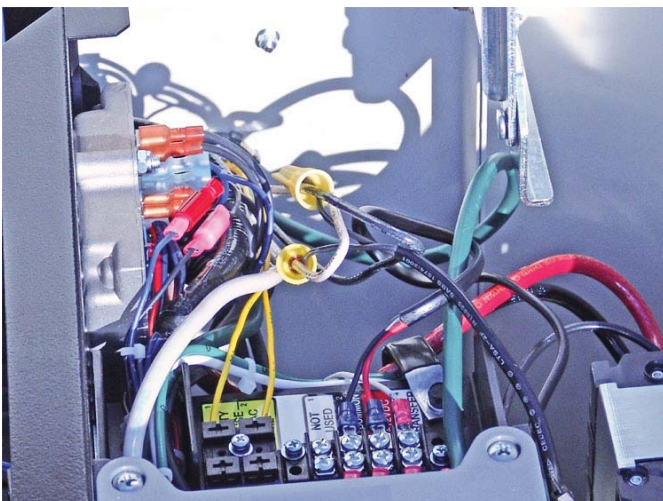


- Dress all wires neatly (Figure 4.7).

**NOTE:**

See the GenReady Installation/Wiring Diagram for connections.

**Figure 4.7 — Completed Charger Connections on Generator Control Panel**



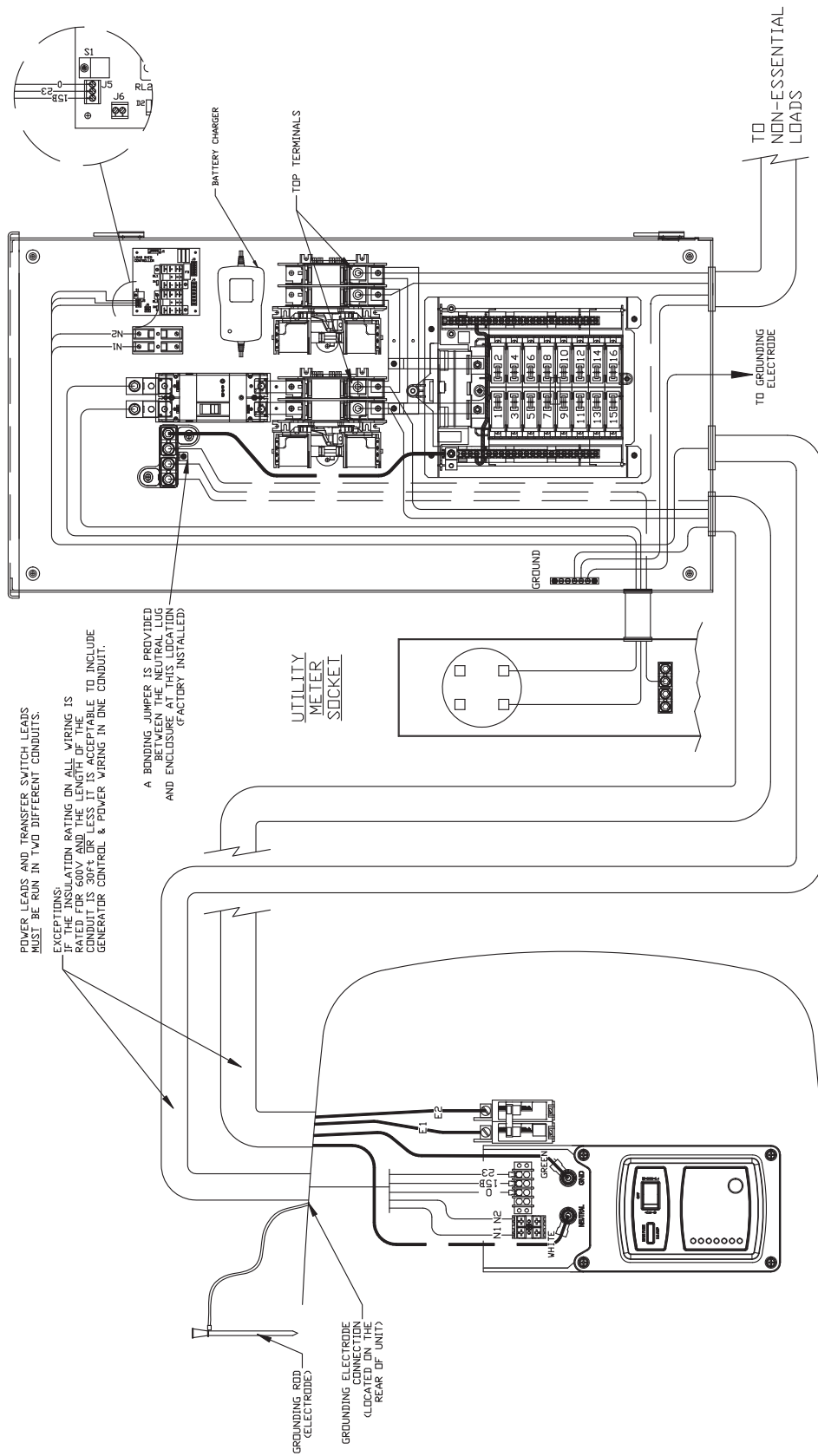
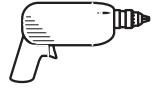
**◆ 4.1.4 OPERATIONAL TESTING**

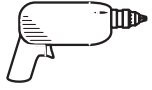
- If already connected, disconnect the battery in the generator. Remove the negative cable first followed by the positive cable. Take care not to short the cables together.
- Ensure power is applied to the battery charger input.
- Connect a volt meter across the battery leads. The voltage reading should be between 12.8VDC and 13.8VDC (Figure 4.8).
- If the voltage is within range installation of the battery charger is complete. If the voltage is not within range verify all wiring and sizing and retest.
- Re-connect the battery cables. Positive cable first followed by the negative cable.

**Figure 4.8 — Measurement of Charger Output with Battery Disconnected**



**Section 5 – Interconnection Diagrams**  
**Battery Charger Installation Guidelines**  
**RTSS Diagram - Drawing No. 0G8774-A**

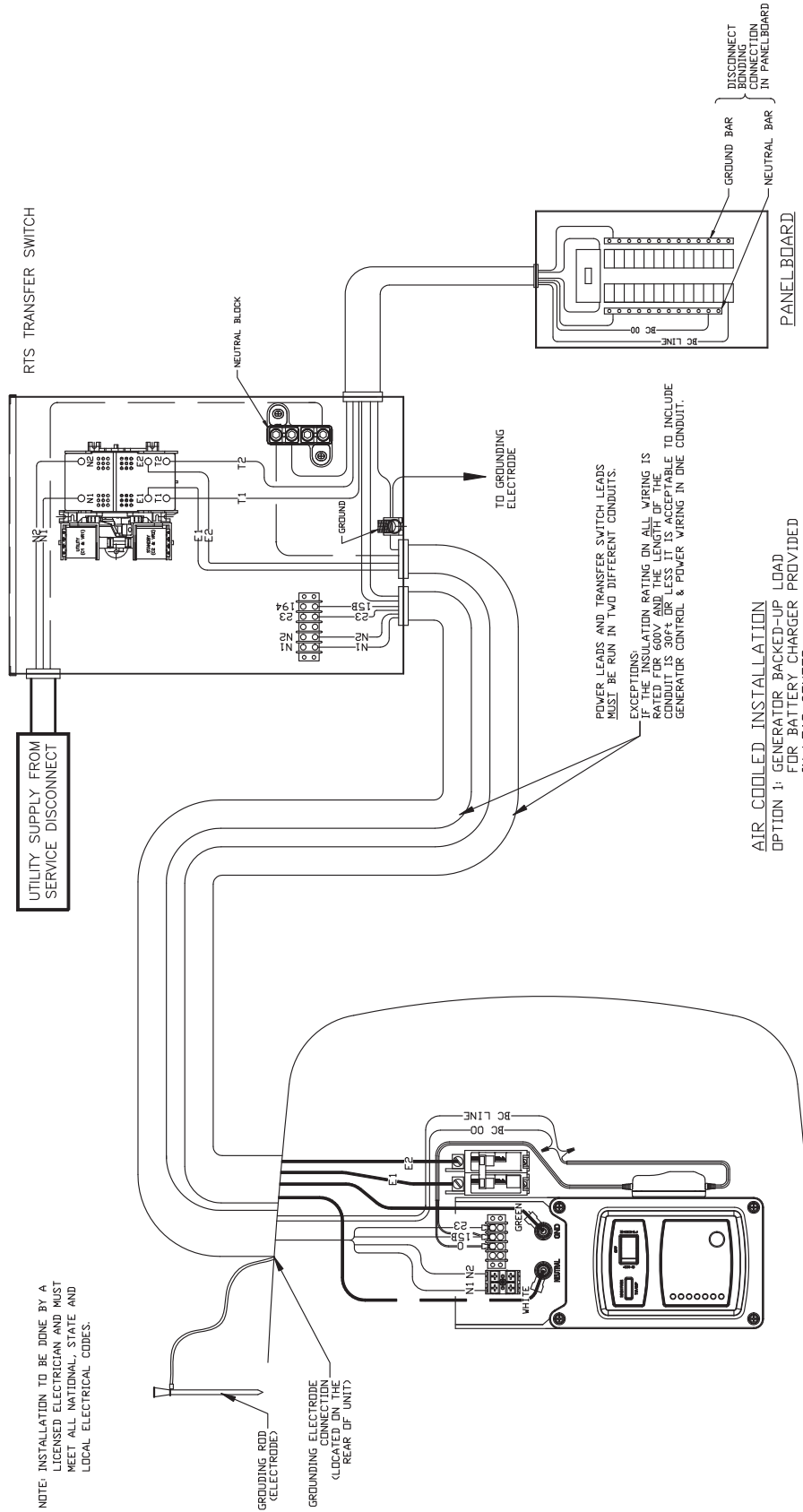




Section 5 – Interconnection Diagrams

Battery Charger Installation Guidelines

RTSN Diagram: Option 1 - Drawing No. 0G8832-A

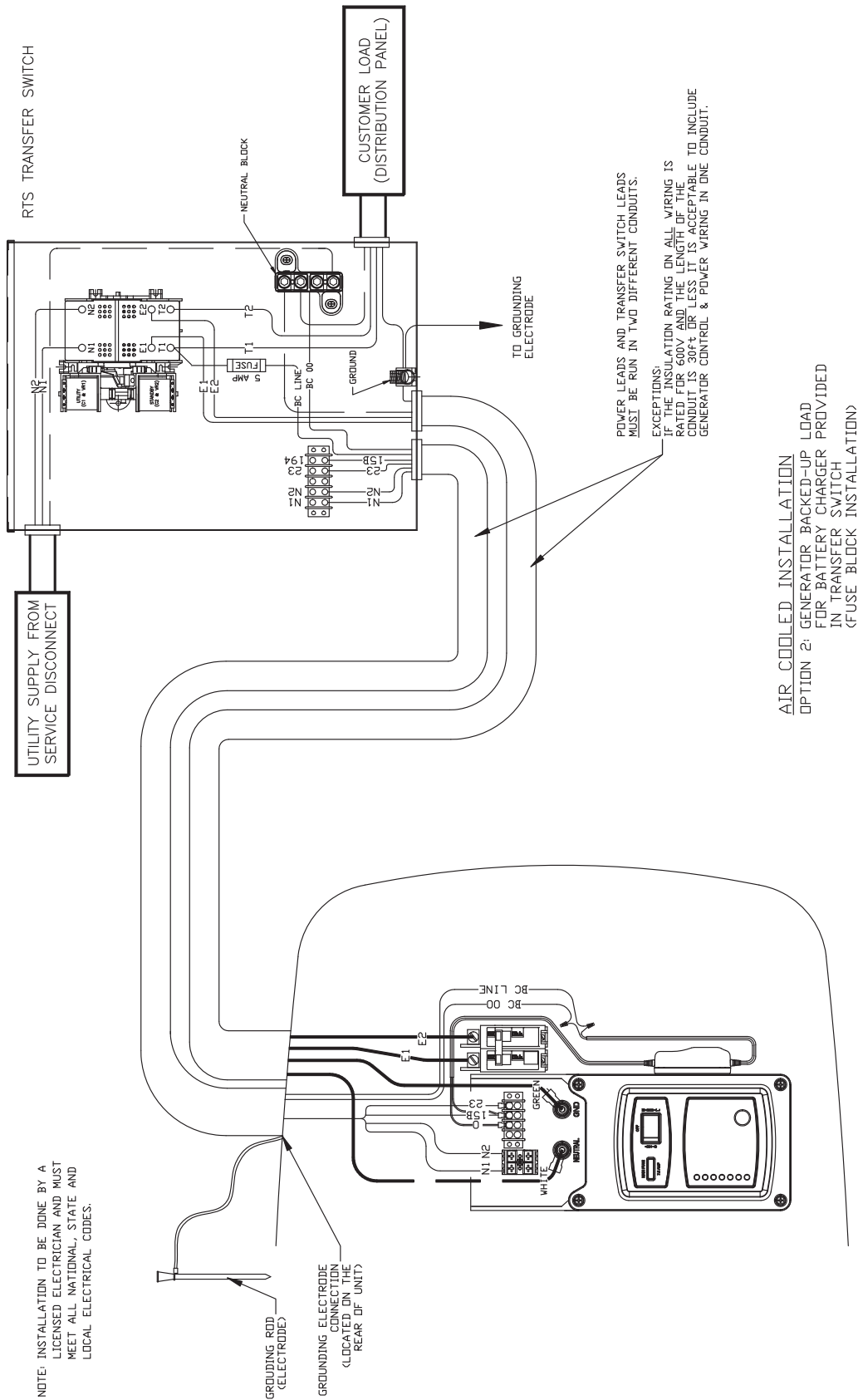


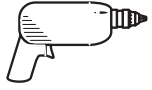
NOTE: INSTALLATION TO BE DONE BY A LICENSED ELECTRICIAN AND MUST MEET ALL NATIONAL, STATE AND LOCAL ELECTRICAL CODES.

GROUNDING ROD (ELECTRODE)  
 GROUNDING ELECTRODE CONNECTION (LOCAL TO REAR OF UNIT)

2008 AND LATER AIR-COOLED HSB GENERATORS

**Section 5 – Interconnection Diagrams**  
**Battery Charger Installation Guidelines**  
**RTSN Diagram: Option 2 - Drawing No. 0G8832-A**

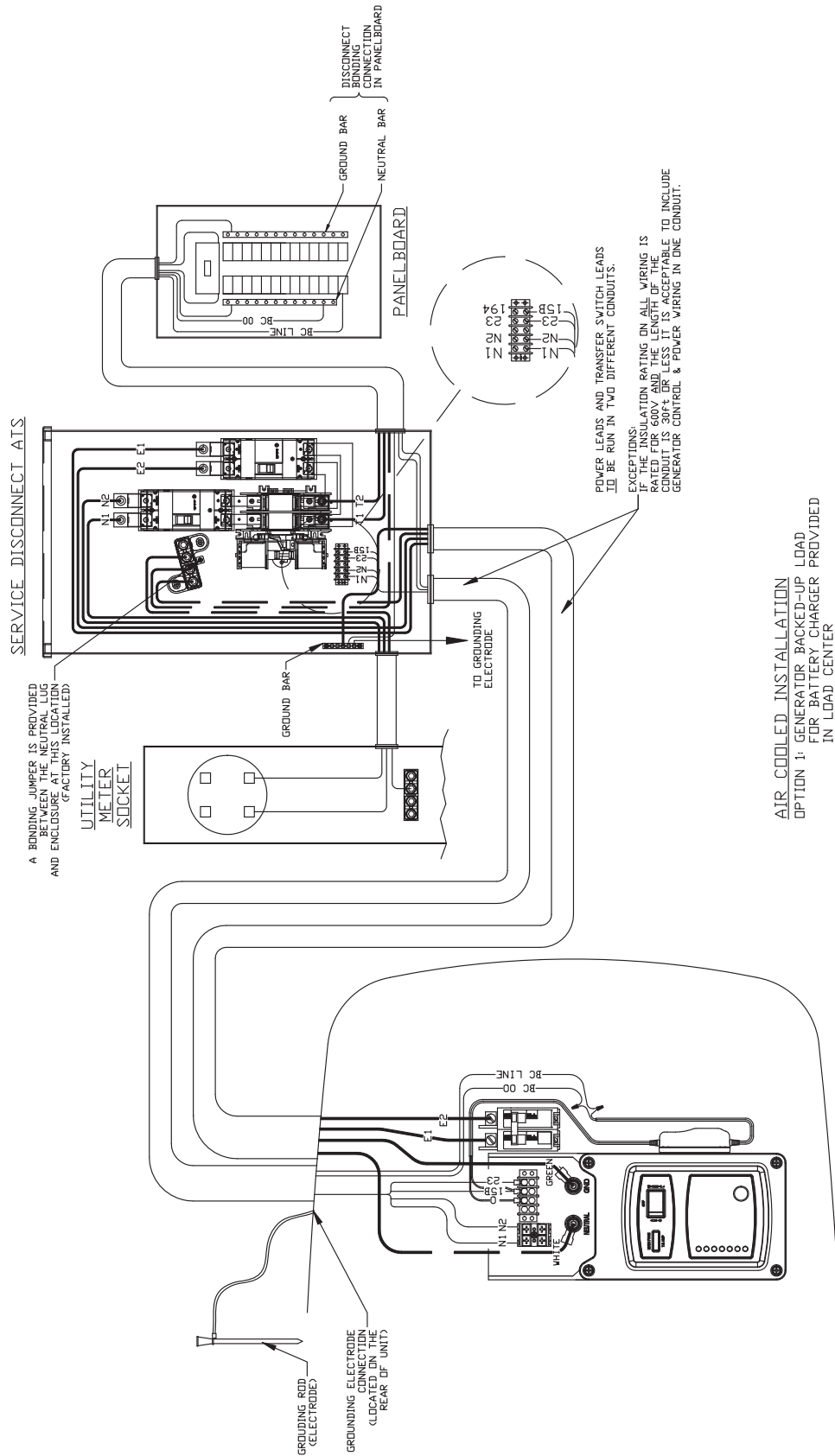




Section 5 – Interconnection Diagrams

Battery Charger Installation Guidelines

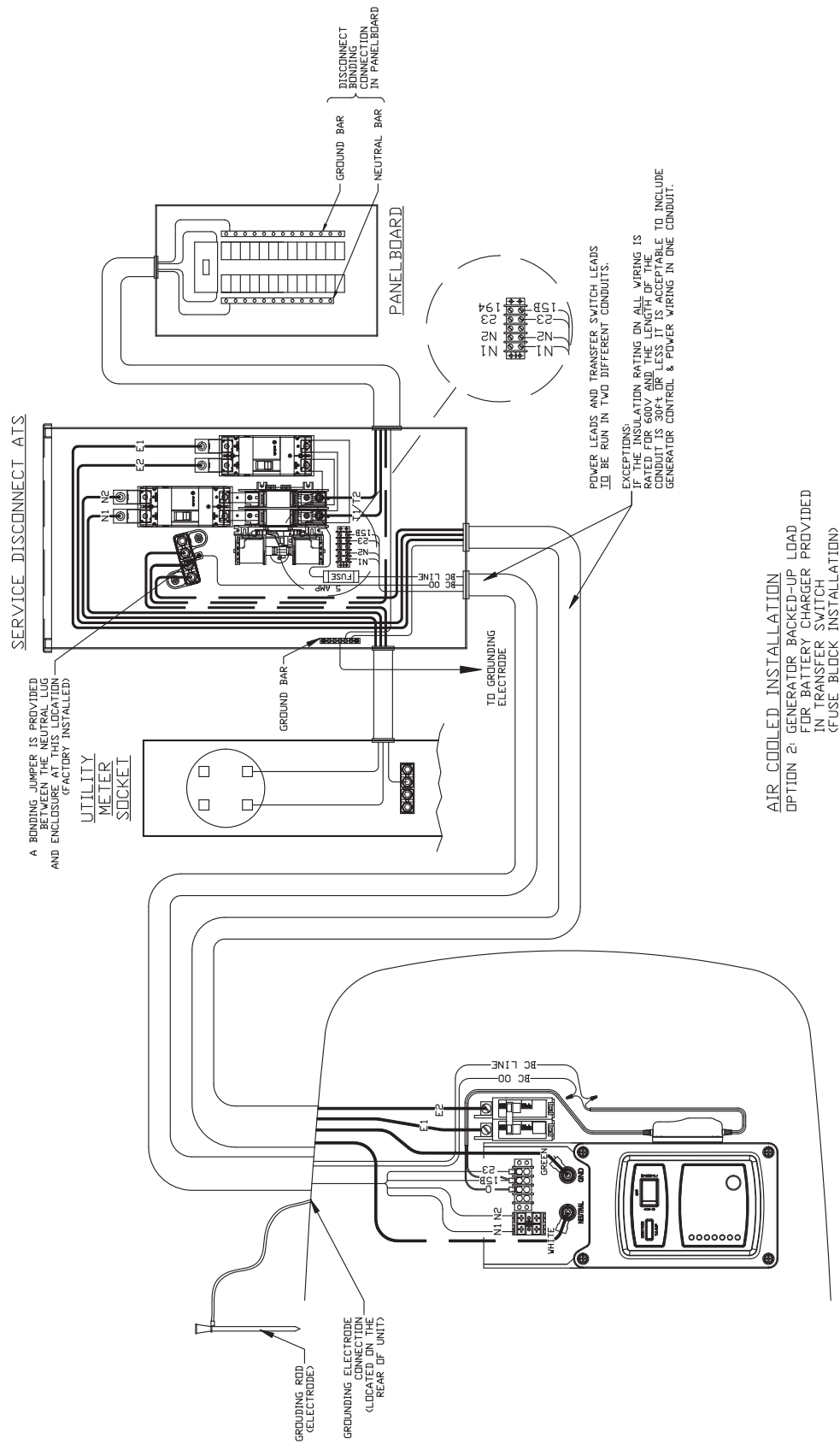
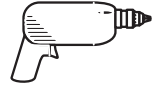
RTSE Diagram: Option 1 - Drawing No. 0G8829-A

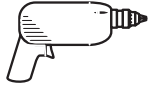


2008 AND LATER AIR-COOLED HSB GENERATORS

**Section 5 – Interconnection Diagrams**  
**Battery Charger Installation Guidelines**  
**RTSE Diagram: Option 2 - Drawing No. 0G8829-A**

INSTALLATION

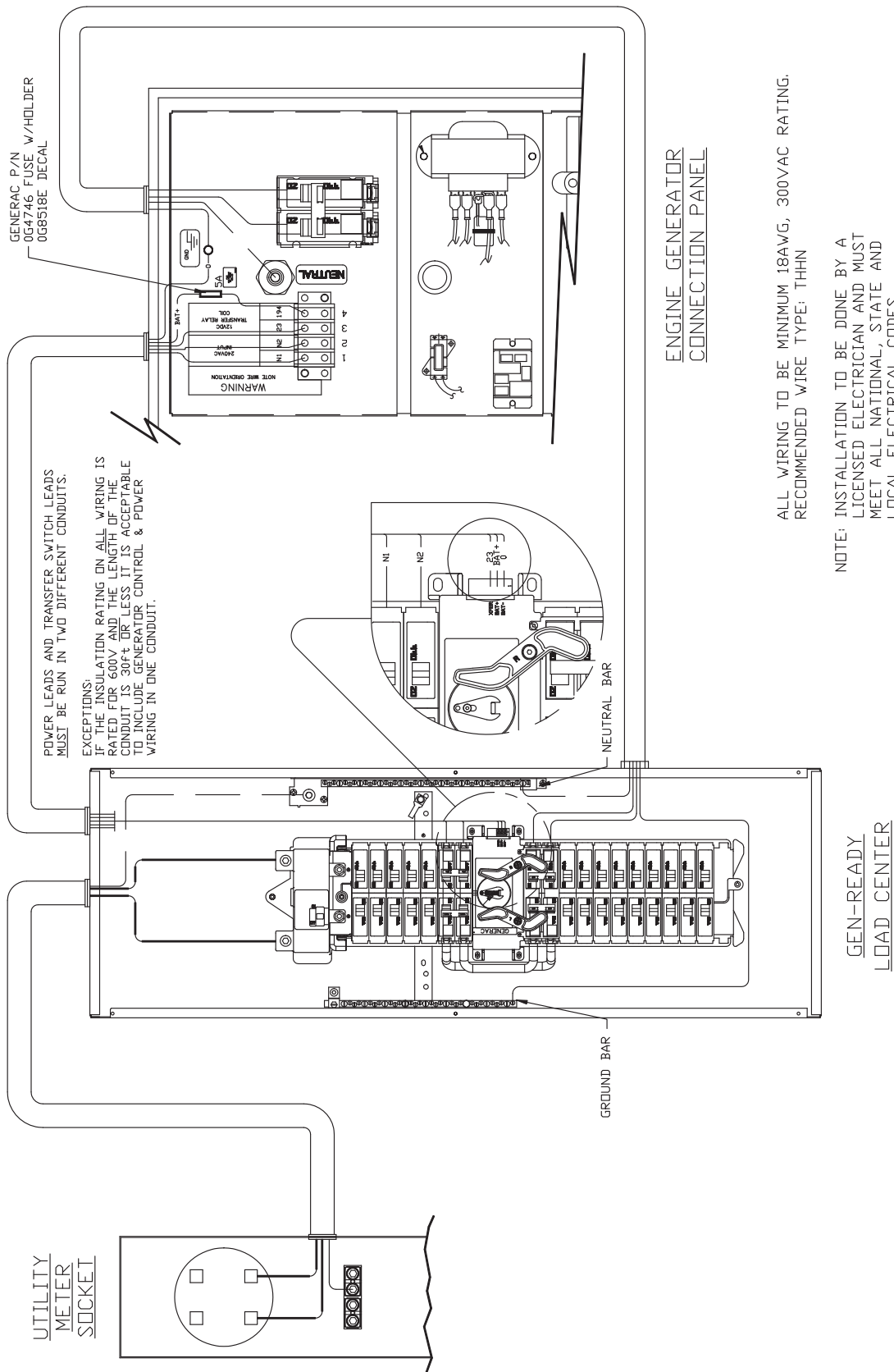




Section 5 – Interconnection Diagrams

Battery Charger Installation Guidelines

GenReady Diagram - Drawing No. 0G4744-C





**Section 5 – Interconnection Diagrams**  
**Battery Charger Installation Guidelines**  
**GenReady Diagram - Drawing No. 0G4744-C**

**INSTALLATION**

