



# INSTALLATION INSTRUCTIONS

## Series CG1000 Electronic Air Cleaner Accessory Media Pad Replacement

**IMPORTANT:** Read entire instructions before starting the air cleaner.

### SAFETY CONSIDERATIONS

Read and follow manufacturer instructions carefully. Follow all local electrical codes during installation. All wiring must conform to local and national electrical codes. Improper wiring or installation may damage air cleaner.

Recognize safety information. This is the safety alert symbol . When the safety alert symbol is present on equipment or in the instruction manual, be alert to the potential for personal injury.

Understand the signal words DANGER, WARNING, and CAUTION. These words are used with the safety alert symbol. DANGER identifies the most serious hazards which will result in severe personal injury or death. WARNING signifies a hazard which could result in personal injury or death. CAUTION is used to identify unsafe practices which would result in minor personal injury or property damage.

### WARNING

Before beginning any modification, be certain that the main line electrical disconnect switch is in the OFF position. Electric shock could result. Tag disconnect switch with suitable warning labels.

Installation and servicing of air-conditioning equipment can be hazardous due to system pressure and electrical components. Only trained and qualified service personnel should install, repair, or service air-conditioning equipment.

Untrained personnel can perform the basic maintenance functions of cleaning and replacing filters. All other operations should be performed by trained service personnel. When working on air-conditioning equipment, observe precautions in the literature, tags and labels attached to the unit, and other safety precautions that may apply.

Follow all safety codes. Wear safety glasses and work gloves.

### GENERAL

The Totaline® Series CG1000 electronic air cleaner is designed to be used in place of a standard, 1-in. filter in the ductwork of a house or building. The accessory media pad replacement is used to replace the fiberglass filters when they become dirty. A total of 6 filters are supplied in each package. Two filters are required for each filter changeout. Contact your Totaline distributor for available sizes.

### INSTALLATION

1. Unplug the power cord from the electronic air cleaner and remove the air cleaner from the filter rack. See Fig. 1.
2. Vacuum the outside mesh screens of the electronic air cleaner if lint is present. A soft cloth and water mixed with detergent can be used to clean the outside of the device. Do not use alcohol, organic solvents, or other chemical agents for cleaning. To avoid electrical damage, do not wash the electronic air cleaner with excessive water.
3. Open the electronic air cleaner by lifting the latches on the side of the frame.
4. Remove the two dirty pads from inside the electronic air cleaner.
5. Place two new media pads on either side of the center screen. See Fig. 2. Be sure the pads fit squarely into the outside retainer screens. Discard old pads.
6. Close the electronic air cleaner and make sure the latches are secured.
7. Place the electronic air cleaner back into the filter rack and plug in the power cord.

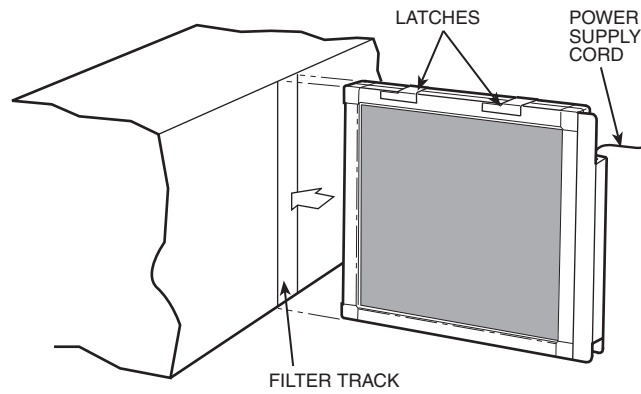

**Fig. 1 — Electronic Air Cleaner Removal**

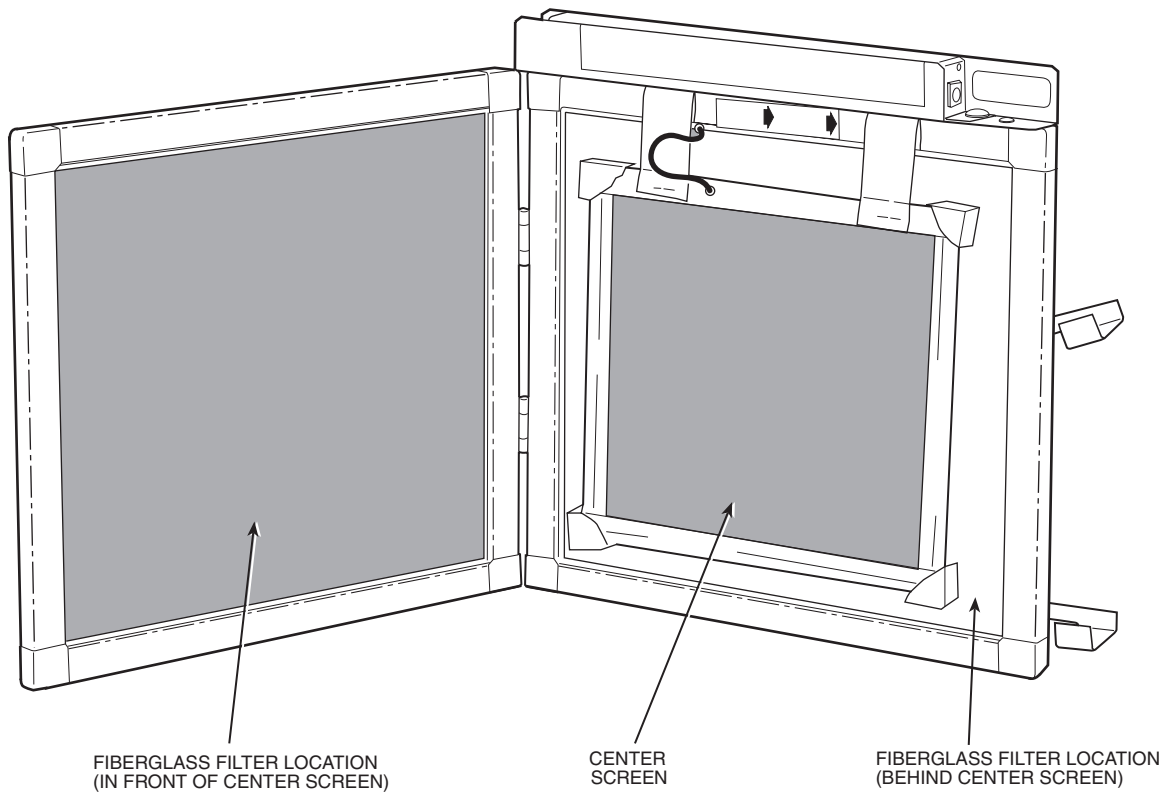

**Fig. 2 — Filter Replacement**