

Part Number P102-650

**SAFETY CONSIDERATIONS**

Installation and servicing of air-conditioning equipment can be hazardous due to system pressure and electrical components. Only trained and qualified service personnel should install, repair, or service air-conditioning equipment.

Untrained personnel can perform basic maintenance functions such as changing filters. All other operations should be performed by trained service personnel. When working on air-conditioning equipment, observe precautions in the literature, tags and labels attached to the unit or accessory, and other safety precautions that may apply.

Follow all safety codes. Wear safety glasses and work gloves.

**▲ WARNING**

Before installing air cleaner or performing maintenance or service on air cleaner, unplug the unit. Electrical shock can cause injury or death.

**GENERAL**

The Totaline® Whole-House HEPA Air Cleaner is designed to remove particulates from the airstream, such as atmospheric and household dust, coal dust, insecticide dust, mites, pollen, mold spores, fungi, bacteria, viruses, pet dander, cooking smoke and grease, and tobacco smoke. The air cleaner also removes odors with a carbon prefilter. The Totaline Whole-House HEPA Air Cleaner helps provide relief from allergies, asthma, and other respiratory problems.

The air cleaner is installed in parallel to the return air duct. The air flows through a 2-stage air filtration system.

**FIELD-SUPPLIED REQUIRED  
COMPONENTS**

- 12-in. diameter, round duct adapter
- 12-in. diameter, round, flexible intake duct
- two 12-in. diameter, round duct clamps
- 8-in. diameter, round duct adapter
- 8-in. diameter, round, flexible exhaust duct
- two 8-in. diameter, round duct clamps
- deflector (optional)
- duct tape

**COMPONENTS**

See Fig. 1 for a picture of the air cleaner. See Table 1 for air cleaner specifications.

**Cabinet** — The cabinet is constructed of heavy gage steel. The cabinet can be free standing or adapted to mount on a wall or be suspended from a ceiling.

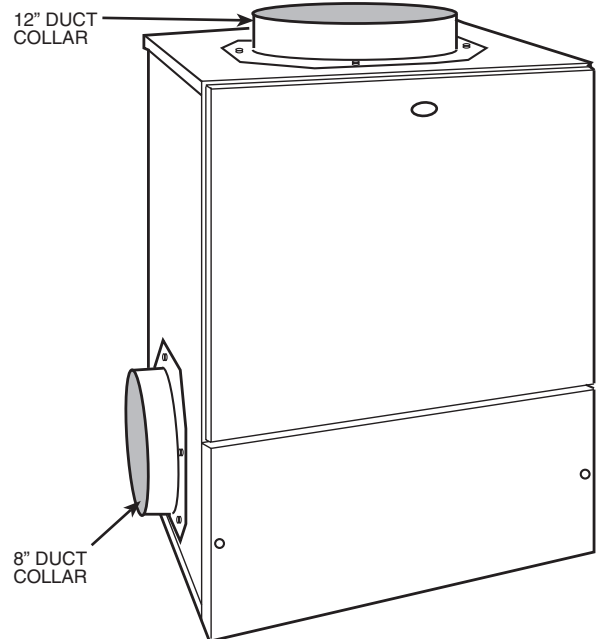
**Fig. 1 — Whole House HEPA Air Cleaner**

**Activated Carbon Prefilter** — The activated carbon prefilter removes lint and odors from the airstream. The filter is an activated carbon impregnated, polyester filter.

**HEPA Filter** — The HEPA (High Efficiency Particulate Air) filter captures 99.97% of particles 0.3 microns (1/84,000-in.) and larger. This HEPA filter has 133 sq ft of collection surface area.

**INSTALLATION**

**Location** — The air cleaner should be located as close to the return air duct as possible. This allows shorter ducting to the air cleaner and keeps static pressure lower.

The unit can be adapted to mount on a wall or be suspended from a ceiling. The unit should not be installed outside or in an area where moisture may leak on the unit.

There must be 36-in. clearance to remove and change filters.

NOTE: If mounting the unit on its back, contact the distributor for a special mounting kit.

**⚠ CAUTION**

Do not connect to the supply side of the system. Damage to equipment could result. Unit must be installed on the return side of system only. Do not install in a cooking area or connect directly to an appliance.

NOTE: Any outside air added to the system from a HRV (Heat Recovery Ventilator) or directly must be introduced before the filtration system.

**Install Filters**

1. Open the access panel. Cut wire ties from holddown bar. Remove the filters from inside the air cleaner by pulling the filter holddown bar forward one side at a time.
2. Remove plastic wrapping from carbon prefilter. Date the HEPA filter in the space provided on top. Wrap carbon prefilter blanket around HEPA filter and secure with Velcro.
3. Ensure the open end of the HEPA filter is facing down toward the motor. Position filter so it is touching the back position bars and is inserted past the line marked on the cabinet.
4. Replace the filter holddown bar by placing one side under the bracket on the side of the cabinet. Once you have one side started, push the bar under the bracket on the other side of the cabinet, ensuring the filter has a good seal. (See Fig. 2.) Close the filter access door.

NOTE: When filters are new, you may notice a new odor from the system. This is normal and will dissipate within a few days.

**Connect Ductwork** — To connect the ductwork to the air cleaner, perform the following:

NOTE: If outside air is introduced into the return air duct, either through a HRV (Heat Recovery Ventilator) or directly, it should be added to the system before the intake inlet to the air cleaner.

1. When the unit is shipped, the intake and exhaust collars are reverse mounted to prevent damage in shipping. The intake collar must be removed and reattached with the collar ring facing out. The exhaust collar can be mounted on one of three sides of the unit with the ring out. *The other two sides will be covered with the exhaust covers. These covers must be installed for the unit to operate properly.*
2. An inlet collar is provided on the unit to allow a flexible 12-in. intake duct, from the cold air return, to be attached. The 12-in. intake must be drawn from the cold air return duct at a location that will be ahead of the clean exhaust air, that will be returned to the duct from the air cleaner.
3. A duct adapter and a length of 12-in. flexible hose or duct is required to attach between the 12-in. intake collar and the existing cold air return duct. When running the hose, make sure that there are no kinks or sharp bends that will impede the airflow to the unit. Secure and seal the hose and connections to prevent air leakage.
4. The 8-in. exhaust collar can be conveniently mounted on one of three sides of the unit. A duct adapter and a length of 8-in. flexible hose or duct is required to attach between the exhaust collar and the existing cold

air return. The exhaust hose should be attached to the return air duct, close to the furnace. The ideal location is low on the return air boot pointing at the furnace. To prevent air shear inside the duct, it is recommended that you install a deflector inside the boot, so the discharged air is deflected down into the boot. See Fig. 3. When running the hose, make sure that there are no kinks or sharp bends that will impede the airflow from the unit. Secure and seal the hose and connections to prevent air leakage.

5. It is important to maintain some distance between the intake and the exhaust openings in the return air duct. Failure to do this may result in short cycling between the intake and the clean air discharge. It is recommended that you leave 10 ft between the intake and the exhaust; however, as little as 6 ft will work effectively. If the distance is smaller than 6 ft, it is important that an air deflector is installed in the duct.

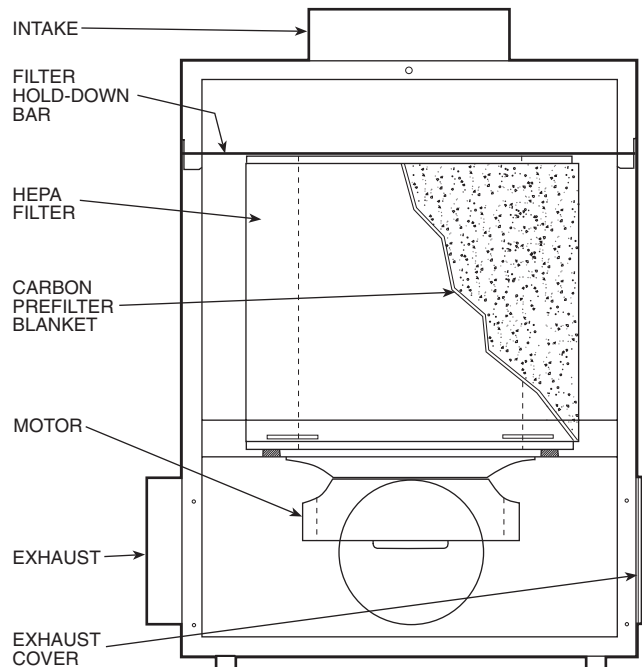

**Fig. 2 — Filter Installation**

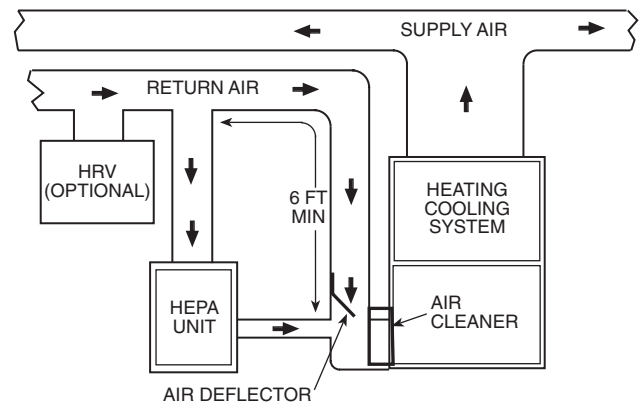

LEGEND  
 HRV — Heat Recovery Ventilator

**Fig. 3 — Typical Air Cleaner Installation**

## OPERATION

### ⚠ WARNING

DO NOT operate unit without a complete filter set installed.

The HEPA Air Cleaner is designed to operate continuously. The heating/cooling system that the air cleaner is connected to should be set accordingly. If the heating/cooling system is set on “automatic” the HEPA Air Cleaner should be connected to an air switch or relay to turn the unit on when the system is operating.

The HEPA Air Cleaner is equipped with a standard 120 v power cord that can be plugged into any 120 v outlet.

NOTE: Avoid unit damage and possible personal injury. DO NOT place cord in high traffic areas.

All filters must be installed correctly and the filter access panel must be secured for proper unit operation.

## MAINTENANCE

### ⚠ WARNING

Unplug unit before performing any maintenance or service on air cleaner. Electrical shock can cause injury or death.

**Carbon Prefilter** — Replace every 3 to 6 months. Vacuum with a soft brush attachment between changes. If there are heavy odors in the home from cooking, smoking, painting or other sources, the filter will require changing more often.

**HEPA Filter** — Replace every 2 to 3 years. The HEPA filter’s service depends on the amount of contaminants in the air

and the frequency of prefilter cleaning/changes. Renovations in the home that create wood, drywall dust or similar contaminants will shorten the life expectancy of the HEPA filter. The filter surface is fragile. Vacuum with a soft brush attachment regularly. If possible, vacuuming should be done outdoors.

NOTE: Handle the HEPA filter by the frame only. Any tears or punctures in the filter material will reduce efficiency.

**Filter Replacement** — Unit filters must be changed on a regular basis to maintain unit efficiency. The prefilter and HEPA filter should be vacuumed regularly to reduce the static pressure drop of the filters between filter changes. Use Totaline® replacement filters only; contact the original installer for replacement parts.

To replace filters:

1. Turn power off and remove filter access door.
2. Release the filter holddown bar by pulling forward.
3. Carefully remove filters to avoid spilling of collected contaminants. Dispose of filters in a plastic bag.
4. Remove plastic from the new filter. Be careful not to damage filter.
5. Date replacement HEPA filter in the space provided.
6. Place the carbon prefilter around the HEPA filter and secure with the Velcro.
7. Ensure the open end of the HEPA filter is facing down toward the motor and is inserted past the line marked on the cabinet.
8. Replace the filter holddown bar, ensuring the filter has a good seal.
9. Reinstall and secure filter access door and turn power on.

Table 1 — Air Cleaner Specifications

<b>Dimensions</b>	<b>Length</b> <b>Width</b> <b>Height</b>	18 in. 18 in. 31 in.	45.7 cm 45.7 cm 78.7 cm
<b>Intake</b>		12 in.	30.5 cm
<b>Outflow</b>		8 in.	20.3 cm
<b>Unit Weight</b>		57 lbs	25.9 kg
<b>Input Voltage</b>		120 V 60 Hz	
<b>Power Consumption</b>		215 Watts	
<b>Airflow</b>		525 CFM	892 m <sup>3</sup> /hr
<b>Cabinet</b>		18 gage	
<b>Power Cord</b>		9.0 ft	2.74 m
<b>Filter Dimensions</b>	<b>Carbon Prefilter</b> <b>HEPA Filter</b>	47 x 15.5 x 0.25 in. 16 (H) x 14.25 (Dia) x 2.375 in.	119.4 x 39.4 x 0.63 cm 40.6 x 36.2 x 6 cm
<b>Carbon Prefilter Collecting Surface Area</b>		5.1 ft <sup>2</sup>	0.47 m <sup>2</sup>
<b>HEPA Collecting Surface Area</b>		133 ft <sup>2</sup>	12.4 m <sup>2</sup>

#### LEGEND

HEPA — High Efficiency Particulate Air



**Your Assurance of Quality**

**ALL Totaline® products are backed with a one-year warranty by Carrier Corporation, the world's largest manufacturer of air conditioning, heating, and refrigeration products.**

**WHOLE-HOUSE HEPA AIR CLEANER  
LIMITED FIVE (5) YEAR WARRANTY**

**FIVE-YEAR WARRANTY** — This CARRIER CORPORATION product is warranted to be free from electrical and mechanical defects in material and workmanship, under normal use within its listed capacity and maintenance, for a period of FIVE (5) years from the date of original installation, excluding the fan/motor assembly which is warranted for ONE (1) year from the date of installation. This warranty does not include the Carbon Prefilter or HEPA Filter. This CARRIER CORPORATION product must not have been moved from the site of original installation. A new or remanufactured part to replace the defective part will be provided without charge for the part itself, through an authorized CARRIER CORPORATION service dealer, provided the defective part is returned to the Distributor. The replacement part assumes the unused portion of the warranty. **Proof of Purchase and Installation** must be provided. Failing this, CARRIER CORPORATION will guarantee the unit for a period of sixty (60) months from the date of manufacture, according to the manufacturer's records and the conditions within this warranty.

**THIS WARRANTY DOES NOT INCLUDE ANY ADDITIONAL LABOR ALLOWANCE OR OTHER COSTS** incurred for diagnosis, repairing, removing, installing, shipping, servicing, or handling of either defective parts or replacement parts. SUCH COSTS MAY BE COVERED BY a separate warranty provided by the installer.

**LIMITATIONS OF WARRANTY** — ALL IMPLIED WARRANTIES (INCLUDING IMPLIED WARRANTIES OF MERCHANTABILITY) ARE HEREBY LIMITED IN DURATION TO THE PERIOD FOR WHICH THE LIMITED WARRANTY IS GIVEN. THE EXPRESSED WARRANTIES MADE IN THIS WARRANTY ARE EXCLUSIVE AND MAY NOT BE ALTERED, ENLARGED, OR CHANGED BY ANY DISTRIBUTOR, DEALER, OR OTHER PERSON WHATSOEVER.

**CARRIER CORPORATION WILL NOT BE RESPONSIBLE FOR:**

1. Normal maintenance as outlined in the Installation, Operation and Maintenance Instructions including cleaning and/or replacement of filters.
2. Damage or repairs required as a consequence of faulty installation or application by others.
3. Damage or repairs needed as a consequence of any misapplication, abuse, improper servicing, unauthorized alteration, or improper operations.
4. Failure to start due to voltage conditions, blown fuses, open circuit breakers or other damages due to the inadequacy or interruption of electrical service.
5. Damage as a result of floods, winds, fires, lightning, accidents, corrosive atmosphere, or other conditions beyond the control of CARRIER CORPORATION.
6. CARRIER CORPORATION products installed outside the continental U.S.A., Alaska, Hawaii, and Canada.
7. Any special indirect or consequential property or commercial damage of any nature whatsoever. Some States do not allow the exclusion of incidental or consequential damages, so the above limitation may not apply to you.

Model No.	Serial No.
Date of Installation	Installed by
Name of Owner	Address of Installation

Manufacturer reserves the right to discontinue, or change at any time, specifications or designs without notice and without incurring obligations.

REPLACEMENT COMPONENTS DIVISION  
© CARRIER CORPORATION 2002 9-02  
PRINTED IN U.S.A.

LITERATURE NUMBER P102-4SI  
CATALOG NO. 570-757