



INSTALLATION, OPERATION, AND MAINTENANCE INSTRUCTIONS

Residential Duct Mount Mechanical Filters

Part Numbers: P102-MF12, P102-MF14A, P102-MF14B, P102-MF20

IMPORTANT: Read entire instructions before installing the mechanical filter.

IF YOU NEED HELP call toll free: 1-800-267-8305

CONTENTS

| | |
|---|-----|
| SAFETY CONSIDERATIONS | 1 |
| GENERAL | 1 |
| COMPONENTS | 1,2 |
| Cabinet | 1 |
| Filter | 1 |
| Carbon Filters | 1 |
| INSTALLATION | 2,3 |
| Location | 2 |
| Mechanical Filter Installation | 2 |
| OPERATION | 4 |
| MAINTENANCE | 4 |
| Main Filter Replacement | 4 |
| Optional Carbon Filter Replacement | 4 |

SAFETY CONSIDERATIONS

Read and follow manufacturer instructions carefully. Improper installation may damage mechanical filter.

Recognize safety information. This is the safety alert symbol . When the safety alert symbol is present on equipment or in the instruction manual, be alert to the potential for personal injury.

Understand the signal words DANGER, WARNING, and CAUTION. These words are used with the safety alert symbol. DANGER identifies the most serious hazards which will result in severe personal injury or death. WARNING signifies a hazard which could result in personal injury or death. CAUTION is used to identify unsafe practices which would result in minor personal injury or property damage.

WARNING

Before beginning any installation or modification, be certain that the main line electrical disconnect switch is in the OFF position. Electric shock could result. Tag disconnect switch with suitable warning labels.

Installation and servicing of air-conditioning equipment can be hazardous due to system pressure and electrical components. Only trained and qualified service personnel should install, repair, or service air-conditioning equipment.

Untrained personnel can perform the basic maintenance functions of replacing filters. All other operations should be performed by trained service personnel. When working on

air-conditioning equipment, observe precautions in the literature, tags and labels attached to the unit, and other safety precautions that may apply.

Follow all safety codes. Wear safety glasses and work gloves.

GENERAL

The mechanical filter is designed to remove atmospheric and household dust, pollen, mold spores, insecticide dust, animal dander, coal dust, mites, cooking smoke and grease, and other particles down to 0.3 microns.

Airborne pollutants are carried through the return air ducts of the heating/cooling system to the mechanical filter. The particles are captured by the filter.

The clean air then passes through the optional carbon filters, where odors are adsorbed.

The optional carbon filter is a polyester pad impregnated with activated carbon. An aluminum frame is used to support the filter. Activated carbon with its naturally unique porous structure, allows excellent odor removal.

The mechanical filter can be easily upgraded to an electronic air cleaner for additional air filtration. Additional clearance above the mechanical filter is required for electronic air cleaner upgrade.

Regular maintenance (replacement of filters) is required by the home owner.

COMPONENTS

See Fig. 1 for a description of the mechanical filter. See Table 1 for mechanical filter specifications.

Cabinet — The cabinet is constructed of heavy gage galvanized steel. Holes are provided in the cabinet for easy mounting in the ductwork or air-handling equipment. See Fig. 2 for cabinet dimensions.

Filter — The filter is constructed of polyolefin fibers that will not shred or absorb moisture. The unique design of the filter includes a structured density gradient with a polarized charge for higher initial and sustained efficiency. The filter media is supported by an open steel mesh and enclosed by a high strength, beverage board. The filters have an Underwriter's Laboratories Class 2 rating.

The efficiency of the filter (MERV 10) is based on ASHRAE (American Society of Heating, Refrigeration, and Air Conditioning Engineers) Standard 52.2. The maximum velocity is 500 ft/min. An arrow indicates direction of airflow.

Carbon Filters — The optional carbon filters are used to remove odors. They are not washable and should be replaced every six months. No more than 3 carbon filters should be used at the same time.

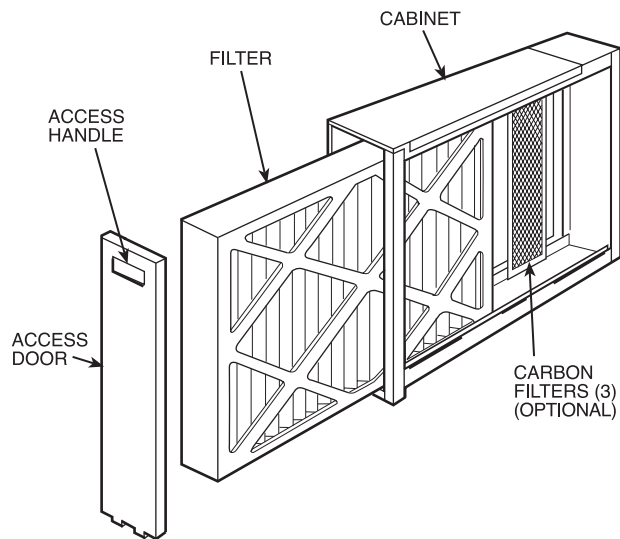

Fig. 1 — Mechanical Filter

Table 1 — Specifications

| PART NUMBER | P102-MF12 | P102-MF14A |
|-----------------|---|---|
| Unit Weight | 17 lb 7.7 kg | 18 lb 8.2 kg |
| House Size Area | < 2400 ft ² < 222.96 m ² | < 3000 ft ² < 278.70 m ² |
| Airflow | up to 1200 CFM up to 2039 m ³ /hr | up to 1400 CFM up to 2379 m ³ /hr |
| Duct Size | 16 x 20 in. 405 x 510 mm | 16 x 25 in. 405 x 635 mm |

| PART NUMBER | P102-MF14B | P102-MF20 |
|-----------------|---|---|
| Unit Weight | 19 lb 8.6 kg | 20 lb 9.1 kg |
| House Size Area | < 3000 ft ² < 278.70 m ² | > 3000 ft ² > 278.70 m ² |
| Airflow | up to 1400 CFM up to 2379 m ³ /hr | up to 2000 CFM up to 3398 m ³ /hr |
| Duct Size | 20 x 20 in. 510 x 510 mm | 20 x 25 in. 510 x 635 mm |

INSTALLATION

Location — The mechanical filter must be installed in the return air duct, as close to the blower compartment as possible. This location provides the most even airflow across the filter and allows the mechanical filter to keep the system motor and blower clean. See Fig. 3. When choosing location, there must be adequate room to remove filters.

NOTE: Be sure to notify home owner not to install any device within 3 ft from the side of the mechanical filter after installation is complete. Regular servicing of the mechanical filter is required. A 3 ft clearance is required to remove filters for maintenance or replacement.

IMPORTANT: The mechanical filter will cause more of a restriction on your heating or cooling system than a regular furnace filter due to its increased efficiency. As the filter collects contaminants, the pressure drop increases. The mechanical filter is not recommended in systems where pressure drop is critical. See Table 2 for pressure drop information.

Table 2 — Mechanical Filter Pressure Drop (in. wg)

| PART NUMBER | CFM | PRESSURE DROP (in. wg) |
|---------------------------|------|------------------------|
| P102-MF12 | 600 | 0.074 |
| | 1200 | 0.24 |
| P102-MF14A, P102-MF14B | 700 | 0.075 |
| | 1400 | 0.25 |
| P102-MF20 | 1000 | 0.076 |
| | 2000 | 0.25 |

INSTALLATION LOCATION WITH HUMIDIFIER — If a separate humidifier is purchased, it should be installed in the furnace warm air duct. However, a humidifier may be installed in the return air duct without causing problems to the mechanical filter. Care must be taken to ensure that the humidifier does not leak, as this may cause damage to the mechanical filter and mineral deposits on the filter.

An atomizing-type humidifier should only be installed downstream of the mechanical filter. If the atomizing-type humidifier is installed upstream, high humidity, salts, and minerals may damage the filter and cause service problems.

If the atomizing-type humidifier must be installed upstream, the atomizing-type humidifier must be installed as far from the mechanical filter as possible.

INSTALLATION LOCATION WITH AIR CONDITIONER — Whenever possible, the mechanical filter should be installed upstream of the cooling coil. This location will clean the air before it reaches the evaporator coil.

Mechanical Filter Installation — Perform the following to install the mechanical filter:

1. Remove the existing furnace filter. Thoroughly clean the blower compartment and ductwork where the mechanical filter is to be installed.
 2. Remove access door. Slide the filter out of the cabinet.
 3. Place cabinet in ductwork. Holes are provided to attach cabinet to ductwork or equipment. If the adjoining ductwork is flanged, install the screws so that the screw heads are inside the cabinet. This will help prevent damage to filters and optional carbon filters during removal for cleaning.
- When the air duct does not fit the mechanical filter opening, a gradual transition is recommended to reduce air turbulence through the mechanical filter and to increase its efficiency. There should not be more than 20 degrees of expansion used on each side of the transition fitting. Do not reduce ductwork to a smaller mechanical filter or it will increase the velocity of airflow.
4. If the mechanical filter is installed adjacent to an elbow or angle fitting, turning vanes are recommended to improve air distribution across the filter.
 5. After mechanical filter has been secured, seal seams airtight with duct tape or caulking to prevent dust from entering the system.
 6. Replace filters. Make sure arrow on filter is pointing towards the fan. Replace the access door.

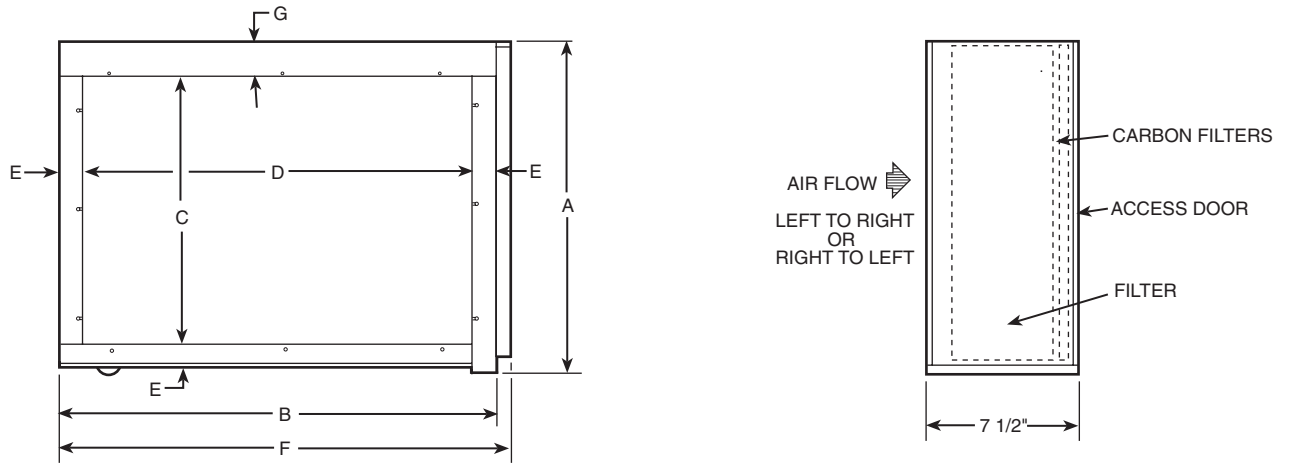

| UNIT | DIMENSIONS — in. (mm) | | | | | | |
|------------|-----------------------|---|---|---|---------------------------------------|---|---------------------------------------|
| | A | B | C | D | E | F | G |
| P102-MF12 | 17 (435) | 23 ¹ / ₄ (590) | 13 ¹ / ₈ (335) | 20 ³ / ₄ (530) | 1 ¹ / ₄ (30) | 23 ³ / ₄ (605) | 2 ³ / ₈ (60) |
| P102-MF14A | 17 (435) | 26 (660) | 13 ⁵ / ₈ (345) | 24 (610) | 1 (25) | 26 ¹ / ₂ (675) | 2 ¹ / ₈ (55) |
| P102-MF14B | 22 (560) | 21 ¹ / ₄ (540) | 18 (460) | 18 ³ / ₄ (476) | 1 ¹ / ₄ (30) | 21 ³ / ₄ (552) | 2 ³ / ₈ (60) |
| P102-MF20 | 22 (560) | 26 (660) | 18 (460) | 23 ¹ / ₂ (595) | 1 ¹ / ₄ (30) | 26 ¹ / ₂ (675) | 2 ³ / ₈ (60) |

Fig. 2 — Dimensions

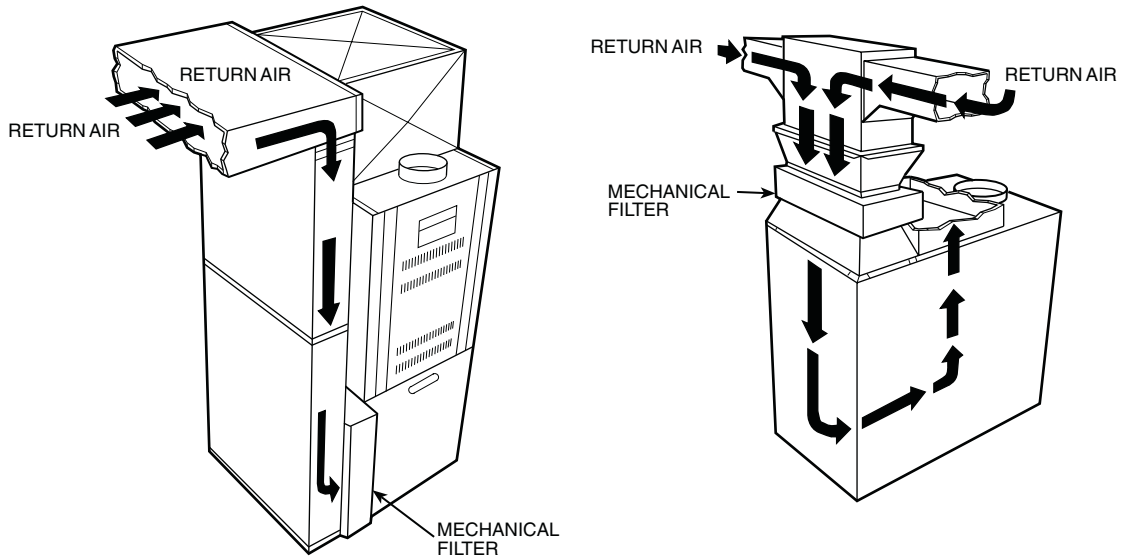

NOTE: Provide a 3 ft (.914 m) clearance for filter removal.

Fig. 3 — Mechanical Filter Installation Location

OPERATION

For maximum performance of the mechanical filter, these steps should be followed:

- run your heating/cooling system fan continuously
- remove furniture or carpets which block return air grilles throughout your house, so that air moves freely to the furnace
- check for proper operation of the blower fan on the furnace
- ensure that the filters are not clogged.

After installation of the mechanical filter, you may notice some white dust on table tops and shelves. Most heavy particles (such as lint) settle quickly and do not get filtered through the mechanical filter. To reduce lint and dust, use continuous fan operation and keep return vents unrestricted to create an efficient airflow.

MAINTENANCE

It is very important that the scheduled maintenance be done by the home owner. If the filter is not changed on a regular basis, the mechanical filter will not operate effectively.

▲ CAUTION

Make sure to turn furnace off before performing any maintenance or removing any components.

Main Filter Replacement — The main filter will need to be replaced once or twice a year, depending on the amount of contaminants in the air. If the filter becomes clogged, airflow

through the system may be restricted. This may cause service problems with the furnace or air conditioner.

To replace the filter:

1. Turn off furnace fan.
2. Open mechanical filter access door.
3. Remove filter from cabinet and discard.
4. Install new filter. Make sure arrow points toward the furnace fan.
5. Close access door.
6. Turn on furnace fan.

Optional Carbon Filter Replacement — Carbon filters should be replaced every 3 to 6 months. Carbon filters remove odors from the air. Filters are NOT washable. To replace filters, perform the following:

1. Turn off furnace fan.
2. Open mechanical filter access door.
3. Remove main filter from mechanical filter cabinet.
4. Pull out the used carbon filters. If the carbon filters do not slide out easily, tilt them at a 45 degree angle and they will fall out.
5. Put new carbon filters into mechanical filter. Space filters evenly across discharge opening of mechanical filter. Never put more than 3 carbon filters in the mechanical filter as this may cause a problem with airflow.
6. Reinstall filter. Close access door.
7. Turn on power to furnace fan.

**MECHANICAL FILTER
LIFETIME LIMITED WARRANTY**

LIFETIME LIMITED WARRANTY — This CARRIER CORPORATION product is warranted to be free from defects in material and workmanship under normal use and maintenance for lifetime of product. The warranty does not apply to replacement of the disposable media filter which will need to be replaced once or twice a year depending on use. A new or remanufactured part to replace the defective part will be provided without charge for the part itself, through a qualified servicing CARRIER CORPORATION dealer or service PROVIDED the defective part is returned to our distributor.

THIS WARRANTY DOES NOT INCLUDE ANY ADDITIONAL LABOR ALLOWANCE, or other costs incurred for diagnosis, repairing, removing, installing, shipping, servicing, or handling of either defective parts or replacement parts. SUCH COSTS MAY BE COVERED BY a separate warranty provided by the installer.

LIMITATIONS OF WARRANTIES — ALL IMPLIED WARRANTIES (INCLUDING IMPLIED WARRANTIES OF MERCHANTABILITY) ARE HEREBY LIMITED IN DURATION TO THE PERIOD FOR WHICH THE LIMITED WARRANTY IS GIVEN. THE EXPRESSED WARRANTIES MADE IN THIS WARRANTY ARE EXCLUSIVE AND MAY NOT BE ALTERED, ENLARGED, OR CHANGED BY ANY DISTRIBUTOR, DEALER, OR OTHER PERSON WHATSOEVER.

CARRIER WILL NOT BE RESPONSIBLE FOR:

1. Normal maintenance as outlined in the installation instructions including replacement of media filters.
2. Damage or repairs required as a consequence of faulty installation or application by others.
3. Damage or repairs needed as a consequence of any misapplication, abuse, improper servicing, unauthorized alteration or improper operations.
4. Damage as a result of floods, winds, fires, lightning, accidents, corrosive atmosphere, or other conditions beyond the control of CARRIER CORPORATION.
5. Parts not supplied or designated by CARRIER CORPORATION.
6. CARRIER CORPORATION products installed outside the continental U.S.A., Alaska, Hawaii and Canada.
7. ANY SPECIAL INDIRECT OR CONSEQUENTIAL PROPERTY OR COMMERCIAL DAMAGE OF ANY NATURE WHATSOEVER. Some states do not allow the exclusion of incidental or consequential damages, so the above limitation may not apply to you.

Model No.

Unit Serial No.

Date of Installation

Installed by

Name of Owner

Address of Installation

TOTALINE[®]

Replacement Components Division • Carrier Corporation
Syracuse, New York

TOTALINE[®]

Gold

Your Assurance of Quality

**ALL Totaline products are backed by Carrier Corporation,
the world's largest manufacturer of air conditioning, heating,
and refrigeration products.**