

Part Number: P102-400DM

TABLE OF CONTENTS

	Page
SAFETY CONSIDERATIONS	1
INTRODUCTION	1,2
INSTALLATION	2,3
Location	2
Duct Mount Installation	3
Collar Mount Installation	3
OPERATION	3
MAINTENANCE	3,4
WHOLE-HOUSE HEPA AIR CLEANER LIMITED FIVE YEAR WARRANTY	5

SAFETY CONSIDERATIONS

Read and follow instructions carefully. Follow all local electrical codes during installation. All wiring must conform to local and national electrical codes. Improper wiring or installation may damage the HEPA (High-Efficiency Particulate Air) air cleaner.

Understand the signal words **WARNING** and **CAUTION** which are present in the Owner's Manual. **WARNING** signifies a hazard or unsafe practices that could result in severe personal injury or death. **CAUTION** signifies a potential hazard or unsafe practice which could result in minor personal injury or property damage.

▲ WARNING

Before beginning any installation or modification, be certain that the main line electrical disconnect switch is in the OFF position. Electric shock could result. Tag disconnect switch with suitable warning labels.

▲ CAUTION

Only a heating and air conditioning installer or qualified service person should install, repair, or service the Whole-House HEPA Air Cleaner.
Homeowners or untrained personnel can perform the basic maintenance functions of replacing filters.

▲ CAUTION

When working on air cleaning equipment, observe precautions in the Owner's Manual, labels attached to the unit, and other safety precautions that may apply. Follow all safety codes. Wear safety glasses and work gloves.

INTRODUCTION

The Whole-House HEPA Air Cleaner has been designed to remove particulate such as atmospheric and household dust, coal dust, insecticide dust, mites, pollen, mold spores, fungi, bacteria, viruses, pet dander, cooking smoke and grease, tobacco smoke and more. The air cleaner has a carbon filter that removes odors. See Fig. 1.

- Helps provide relief from allergies, asthma, and other respiratory illness.
- Helps reduce housekeeping time and redecorating costs.
- Provides a healthier, more comfortable environment, year-round.

Millions of airborne pollutants are carried through the return air ducts of the heating/cooling system. The HEPA air cleaner has been designed to be installed on the return air duct. A portion of this return air is bypassed through an opening on the rear of the unit and passes through a 3-stage filtration system.

The air passes through an efficient pleated MERV 8 (Minimum Efficiency Reporting Value) prefilter to remove lint and large particles to extend the life of the HEPA filter.

The activated carbon filter (activated carbon impregnated polyester filter) removes odors before they enter the HEPA filter.

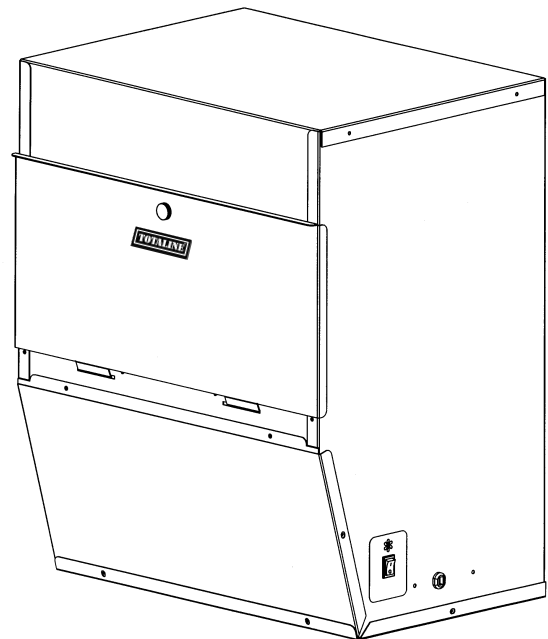

Fig. 1 — P102-400DM Unit

Smaller particles then pass through a long-life, HEPA (High Efficiency Particulate Air) filter which captures 99.97% of particles 0.3 micron (1/84,000 of an inch) and larger. This HEPA filter has more than 40 sq ft of collection surface area. See Table 1.

Clean air is discharged back into the return air duct. See Fig. 2.

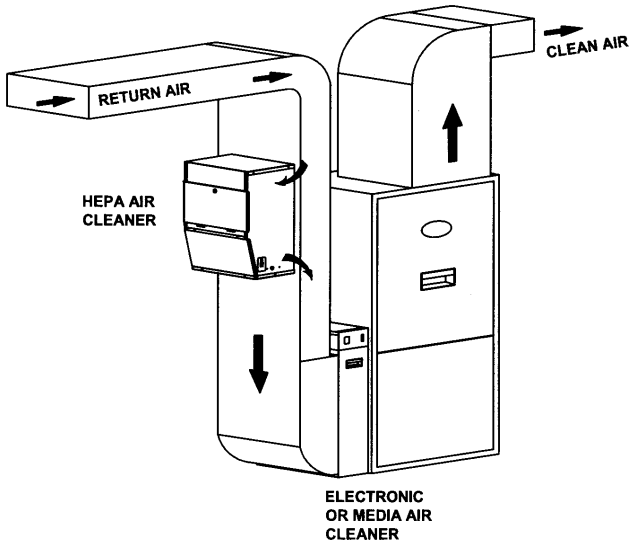

Fig. 2 — Duct Mount Installation

INSTALLATION

Location

IMPORTANT: This unit must be installed on the return air side of the system only. Do not connect to supply side. Do not install in a cooking area or connect directly to any appliance.

The HEPA air cleaner can be installed directly on the return air duct, eliminating the need for external ducting. The unit can also be mounted on the floor or a wall. Use collars to duct the

unit into the return air plenum when suspended from the ceiling. It can also be used as a free-standing unit (see Fig. 3 and 4). Care should be taken to keep the unit away from an area where there is a possibility of moisture leaking onto the unit. **Ensure there is adequate room in front of the unit to remove the filters for replacement.**

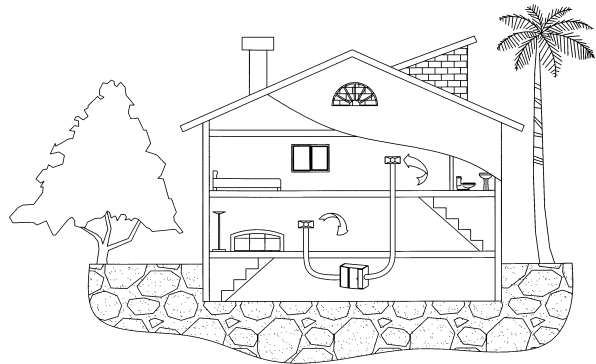

Fig. 3 — Self-Contained Basement Installation

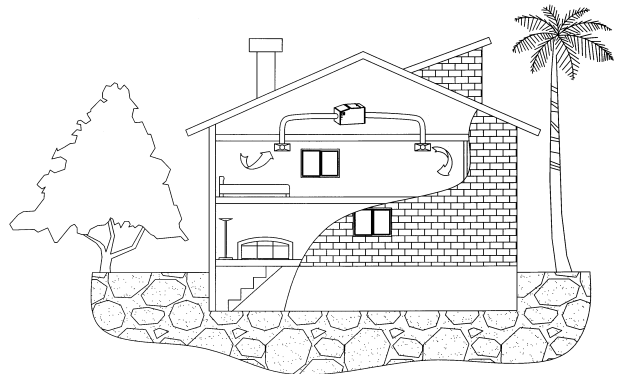

Fig. 4 — Self-Contained Attic Installation

Table 1 — Physical Data

Dimensions	Height	20.125 in.	51.1 cm
	Width	16.25 in.	41.3 cm
	Depth	12.75 in.	32.4 cm
Intake		14.5 x 3.75 in. or 8 in. (dia)	36.8 x 9.5 cm or 20.3 cm (dia)
Outflow		14.5 x 4.37 in. or 8 in. (dia)	36.8 x 11.1 cm or 20.3 cm (dia)
Unit Weight		38 lb	17.2 kg
Input Voltage		120 V 60 Hz	
Power Consumption		125 Watts	
Airflow		320 cfm	544 m ³ /hr
Cabinet		22 gage	
Power Cord		9.0 ft	2.74 m
Filter Dimensions	Prefilter	16 x 12 x 1 in.	40.6 x 30.5 x 2.5 cm
	HEPA Filter	16 x 12 x 2.5 in.	40.6 x 30.5 x 5 cm
	Carbon Filter	16 x 12 x .5 in.	40.6 x 30.5 x 1.3 cm
HEPA Collecting Surface Area		40 sq ft	3.7 sq m

Duct Mount Installation

1. Remove any packaging, as well as the door and filters before installing. See Maintenance for instructions to remove the filters.
2. If the unit is to be mounted on the return air plenum, it must be installed after the last return branch connection on the plenum. If outside air is introduced into the return air duct, either through a HRV (Heat Recovery Ventilator) or directly, it should be added to the system before the intake inlet to the air cleaner.
3. Tape the mounting template level on the plenum and cut and drill the necessary holes as marked.
4. Cut the small joints on the mounting flaps on the back of the unit as indicated. Bend all the flaps outward slightly less than 90 degrees, except for the upper bottom flap which should be bent up at a 40 degree angle only. This bottom flap will act as a deflector for the exhaust air entering back into the plenum.
5. Place the gasket material around the two openings on the back of the air cleaner. Place the unit on the plenum so the flanges are placed through the holes cut in the duct. Fold all the flanges over, except for the upper bottom flap, to enclose the duct between the flanges and the unit. The upper bottom flap should be bent up at a 40 degree angle only.
6. Secure the unit to the duct with the screws provided.

Collar Mount Installation — Inlet collars are available as a kit from the distributor. See Fig. 5.

1. This unit can be installed with collars and flexible ducting if desired. Openings are pre-punched on the top and bottom of the unit for this purpose. Remove the plastic film over the holes and snip out the joints to open the hole. Do not open the holes in the back of the unit if the air cleaner is being collar mounted.
2. The collar is installed with the flange on the inside of the cabinet with only the collar ring on the outside of the cabinet. Compress the collar until a flange can be inserted into the opening in the enclosure. Enlarge the collar to its maximum and install two screws into the ring to hold it to the proper diameter. Turn the collar in the hole until the holes in the enclosure line up to the holes on the collar flange. Secure with the screws provided.
3. The intake collar on the return duct must be installed after the last return branch connection on the plenum.

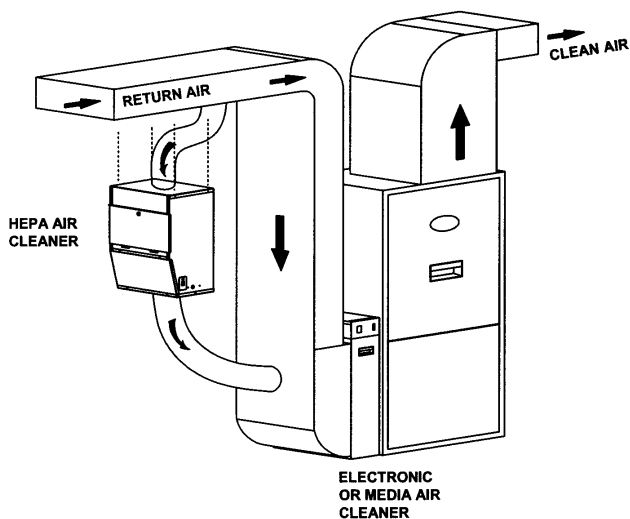

Fig. 5 — Collar Mount Installation

If outside air is introduced into the return air duct, either through a HRV (Heat Recovery Ventilator) or directly, it should be added to the system before the intake inlet to the air cleaner.

4. The 8 in. intake collar (top) must draw air from the return duct at a location that will be ahead of the clean exhaust air, that will be returned to the duct from the air cleaner.
5. An 8 in. collar will be installed on the return duct and a length of 8 in. flexible hose or duct is required to attach between the 8 in. intake collar and the collar on the return duct. When running the hose, make sure that there are no kinks or sharp bends that will impede the airflow to the unit. Secure and seal the hose or duct and connections to prevent air leakage.
6. The 8 in. exhaust collar can be mounted in the same manner to the bottom of the unit. An 8 in. collar will be installed on the return duct close to the furnace and a length of 8 in. flexible hose or duct is required to attach between the exhaust collar and the collar on the return duct. The ideal location is low on the return air boot pointing at the furnace. To prevent air shear inside the duct, it is recommended that a deflector be installed inside the boot, so the discharged air is deflected down into the boot. When running the hose, make sure that there are no kinks or sharp bends that will impede the airflow from the unit. Secure and seal the hose and connections to prevent air leakage.

OPERATION

⚠ CAUTION

Do not use the unit without all of the filters in place. The HEPA filter life will be reduced.

The HEPA air cleaner is designed to run continuously to provide clean, filtered air 24 hours a day. The fan on the heating/cooling system, to which the HEPA air cleaner is dependent on for circulated air, should be on 'continuous'.

NOTE: If the system fan setting is on 'automatic', it is recommended that the HEPA air cleaner be operated through an air switch or relay to turn the air cleaner off when there is no system fan on.

The unit plugs into a regular 120 volt outlet and is controlled by a switch located on the bottom of the unit, near the cord.

NOTE: Do not place the cord where it might be walked on or where something might be rolled over the cord.

The door must be secured for the air cleaner to operate. All filters must be in place for the unit to operate properly.

MAINTENANCE

For efficient operation, the filters must be changed on a regular basis. If you notice a reduction in airflow from the system, check the filters. See Fig. 6.

⚠ CAUTION

Make sure to turn air cleaner OFF before performing any maintenance or removing any components.

1. To access the filters, turn the air cleaner OFF at the switch and remove the front door.
2. Carefully remove filters to avoid spilling collected contaminants. Dispose of filters in a plastic bag and discard with regular household trash.

3. Remove plastic from new filters before installing. Discard plastic safely. Take care not to damage the filters. Hold by the frame only.
4. Date the replacement filter in the space provided.
5. Place the filters in their appropriate track with the arrows pointing toward the fan.
6. Use genuine replacement filters only. Call the original installer for parts.

NOTE: When the filters are new, a new smell may be detected from the system. This is normal and will dissipate within a few hours.

MERV 8 Prefilter — This must be replaced every 3 to 6 months. A clean prefilter will increase the life of the HEPA filter and improve airflow.

HEPA Filter — Replace every 2 to 3 years. The life of this filter depends on the amount of contaminants in the air and the frequency with which the prefilter has been changed. Renovations in the home that create wood or drywall dust or similar contaminants will shorten the life expectancy of the HEPA filter.

Activated Carbon Prefilter — This must be replaced every 3 to 6 months. If there are heavy odors in the home from cooking, smoking, painting or other sources, the filter will require changing more often.

NOTE: Handle the HEPA filter by the frame only. The paper is fragile and a puncture or tear will reduce efficiency.

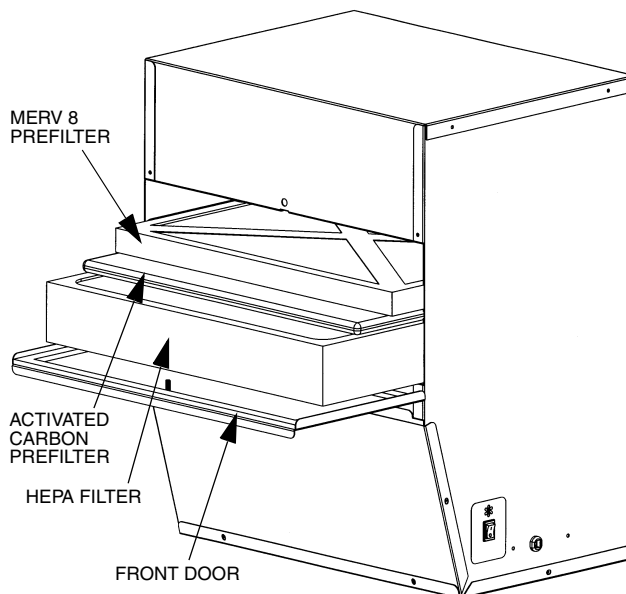

Fig. 6 — Filter Position

**WHOLE-HOUSE HEPA AIR CLEANER
LIMITED FIVE (5) YEAR WARRANTY**

FIVE-YEAR WARRANTY — This Totaline product is warranted to be free from electrical and mechanical defects in material and workmanship, under normal use within its listed capacity and maintenance, for a period of FIVE (5) years from the date of original installation, excluding the fan motor which is warranted for ONE (1) year from date of installation. The warranty does not include the Prefilter, HEPA Filter or Carbon Filter. This Totaline product must not have been moved from the site of original installation. A new or remanufactured part to replace the defective part will be provided without charge for the part itself, through an authorized Totaline service dealer, provided the defective part is returned to the Totaline distributor **prepaid**. The replacement part assumes the unused portion of the warranty. **Proof of Purchase and Installation** must be provided. Failing this, Totaline will guarantee the unit for a period of sixty (60) months from the date of manufacture, according to the manufacturer's records and the conditions within this warranty.

THIS WARRANTY DOES NOT INCLUDE ANY ADDITIONAL LABOR ALLOWANCE OR OTHER COSTS, incurred for diagnosis, repairing, removing, installing, shipping, servicing, or handling of either defective parts or replacement parts. **SUCH COSTS MAY BE COVERED BY** a separate warranty provided by the installer.

LIMITATIONS OF WARRANTY — ALL IMPLIED WARRANTIES (INCLUDING IMPLIED WARRANTIES OF MERCHANTABILITY) ARE HEREBY LIMITED IN DURATION TO THE PERIOD FOR WHICH THE LIMITED WARRANTY IS GIVEN. THE EXPRESSED WARRANTIES MADE IN THIS WARRANTY ARE EXCLUSIVE AND MAY NOT BE ALTERED, ENLARGED, OR CHANGED BY ANY DISTRIBUTOR, DEALER, OR OTHER PERSON WHATSOEVER.

TOTALINE WILL NOT BE RESPONSIBLE FOR:

1. Normal maintenance as outlined in the Installation, Operation and Maintenance Instructions including cleaning and/or replacement of filters.
2. Damage or repairs required as a consequence of faulty installation or application by others.
3. Failure to start due to voltage conditions, blown fuses, open circuit breakers or other damages due to the inadequacy or interruption of electrical service.
4. Damage or repairs needed as a consequence of any misapplication, abuse, improper servicing, unauthorized alteration, or improper operations.
5. Damage as a result of floods, winds, fires, lightning, accidents, corrosive atmosphere, or other conditions beyond the control of Totaline.
6. Parts, including filters, not supplied or designated by Totaline.
7. Totaline products installed outside the continental U.S.A., Alaska, Hawaii, and Canada.
8. ANY SPECIAL INDIRECT OR CONSEQUENTIAL PROPERTY OR COMMERCIAL DAMAGE OF ANY NATURE WHATSOEVER. Some states do not allow the exclusion of incidental or consequential damages, so the above limitation may not apply to you.

Model No.:

Serial No.:

Date of Installation:

Installed by:

Name of Owner:

Address of Installation:

TOTALINE®

Your Assurance of Quality

ALL Totaline® products are backed with a one-year warranty by Carrier Corporation, the world's largest manufacturer of air conditioning, heating, and refrigeration products.