



INSTALLATION, OPERATION, AND MAINTENANCE INSTRUCTIONS

1300 Series Electronic Air Cleaner

IMPORTANT: Read entire instructions before installing the electronic air cleaner.

IF YOU NEED HELP call toll free: 1-800-565-5326

CONTENTS

SAFETY CONSIDERATIONS	1
PACKAGE USAGE	1
GENERAL	1
COMPONENTS	2
Frames with Outer Screens	2
Collecting Pads	2
Charging Bar	2
High Voltage Power Supply Box	2
INSTALLATION	2,3
Location	2
Electronic Air Cleaner Installation	3
OPERATION	3
MAINTENANCE	3-5
Collecting Pad Replacement	3
TROUBLESHOOTING	5

SAFETY CONSIDERATIONS

Read and follow manufacturer instructions carefully. Improper installation may damage media air cleaner.

Recognize safety information. This is the safety alert symbol . When the safety alert symbol is present on equipment or in the instruction manual, be alert to the potential for personal injury.

Understand the signal words DANGER, WARNING, and CAUTION. These words are used with the safety alert symbol. DANGER identifies the most serious hazards which will result in severe personal injury or death. WARNING signifies a hazard which could result in personal injury or death. CAUTION is used to identify unsafe practices which would result in minor personal injury or property damage.

WARNING

Before beginning any installation or modification, be certain that the main line electrical disconnect switch is in the OFF position. Electric shock could result. Tag disconnect switch with suitable warning labels.

Installation and servicing of air-conditioning equipment can be hazardous due to system pressure and electrical components. Only trained and qualified service personnel should install, repair, or service air-conditioning equipment.

Untrained personnel can perform the basic maintenance functions of replacing collecting pads. All other operations should be performed by trained service personnel. When working on air-conditioning equipment, observe precautions in the literature, tags and labels attached to the unit, and other safety precautions that may apply.

Follow all safety codes. Wear safety glasses and work gloves.

PACKAGE USAGE

PART NUMBER	SIZE (in.)
P130-1224C	12 x 24
P130-1424C	14 x 24
P130-1425C	14 x 25
P130-1430C	14 x 30
P130-1520C	15 x 20
P130-1620C	16 x 20
P130-1624C	16 x 24
P130-1625C	16 x 25
P130-1820C	18 x 20
P130-2020C	20 x 20
P130-2024C	20 x 24
P130-2025C	20 x 25
P130-2424C	24 x 24
P130-2425C	24 x 25
P130-2430C	24 x 30

GENERAL

The electronic air cleaner is designed to remove atmospheric and household dust, pollen, mold spores, bacteria, fungi, insecticide dust, animal dander, coal dust, mites, cooking smoke and grease, tobacco smoke, and other particles down to sub-micron levels.

The electronic air cleaner is installed in the furnace filter rack where a filter would normally be placed. It is designed to be installed in a 1-in. filter track. Many sizes are available to fit in different size air ducts.

Airborne pollutants are carried through the return air ducts of the heating/cooling system to the electronic air cleaner. The collecting pads of the electronic air cleaner utilize electronic polarization and ionization to create high filtration efficiencies. The particles are captured by the collecting pads. The 1-in. design protects HVAC equipment and their energy efficiencies due to the electronic air cleaner's low static pressure.

Regular maintenance (replacement or cleaning of collecting pads) is required by the home owner.

COMPONENTS

See Fig. 1 for a description of the electronic air cleaner.

Frames with Outer Screens — The frame is made up of two sides. An optional key is supplied with the frame and may be used to lock and unlock the corner fasteners. The key is located over the top of the outlet and LED lights. The outer screens may be vacuumed or washed when dirty.

Collecting Pads — The collecting pads are used to filter the air. One of the collecting pads will contain carbon fibers which are used to ionize and polarize the pads. The pads cannot be washed or vacuumed and must be replaced when dirty.

Charging Bar — The charging bar is laid across the top of the collecting pad with the carbon fibers and must be in contact with the carbon fibers on the pad. The charging bar is energized by the high voltage power supply box.

High Voltage Power Supply Box — The high voltage power supply box provides power to the electronic air cleaner. A 24-V supply cord and jack is provided for wiring to a 24-V power source.

INSTALLATION

Location — If a filter rack exists, then the electronic air cleaner should be installed in the filter rack. Note the dimensions of the filter rack and order the appropriate sized electronic air cleaner to fit the rack.

If a filter rack does not exist, then the electronic air cleaner must be installed in the return air duct, as close to the blower compartment as possible. This location provides the most even airflow across the collection pads and allows the electronic air cleaner to keep the system motor and blower clean. When choosing location, there must be adequate room to remove the electronic air cleaner. It is best to use the largest possible electronic air cleaner size for installation.

Be sure to allow room for routing the 24-V power wiring to a 24-VAC power source.

NOTE: Be sure to notify home owner not to install any device within 3 ft from the side of the electronic air cleaner after installation is complete. Regular servicing of the electronic air cleaner is required. A 3-ft clearance is required to remove electronic air cleaner and collection pads for maintenance or replacement.

HIGHBOY FURNACE — The filter rack is normally located in the return air duct.

LOWBOY FURNACE — The filter rack is normally located in the blower compartment section. Remove the blower compartment door to view filter rack.

ELECTRIC FURNACE — The filter rack is normally located in the bottom furnace section, located horizontally above the filter box.

LOWBOY FURNACE (OIL) — The filter rack is normally located in the blower compartment section. Remove the blower compartment door to view filter rack. Some older furnaces are equipped with two racks, an upper horizontal and a lower diagonal. The air cleaner would be placed in the lower diagonal filter rack.

HORIZONTAL FURNACE — The filter rack is normally located in the return air duct.

FULL SIZE EXISTING ELECTRONIC AIR CLEANER — If the new electronic air cleaner is replacing an existing full size air cleaner, be sure to turn off the existing air cleaner before removal.

INSTALLATION LOCATION WITH HUMIDIFIER — If a separate humidifier is purchased, it should be installed in the furnace warm air duct. However, a humidifier may be installed in the return air duct without causing problems to the electronic air cleaner. Care must be taken to ensure that the humidifier does not leak, as this may cause damage to the electronic air cleaner and mineral deposits on the air cleaner.

Wet collection pads may cause arcing or shorts on the electronic air cleaner. Wet collection pads may also decrease electronic air cleaner efficiency.

NOTE: An atomizing-type humidifier should only be installed downstream of the electronic air cleaner. If the atomizing-type humidifier is installed upstream, high humidity, salts, and minerals may damage the electronic air cleaner and cause service problems. If the atomizing-type humidifier must be installed upstream, the atomizing-type humidifier must be installed as far from the electronic air cleaner as possible.

INSTALLATION LOCATION WITH AIR CONDITIONER — Whenever possible, the electronic air cleaner should be installed upstream of the cooling coil. This location will clean the air before it reaches the evaporator coil.

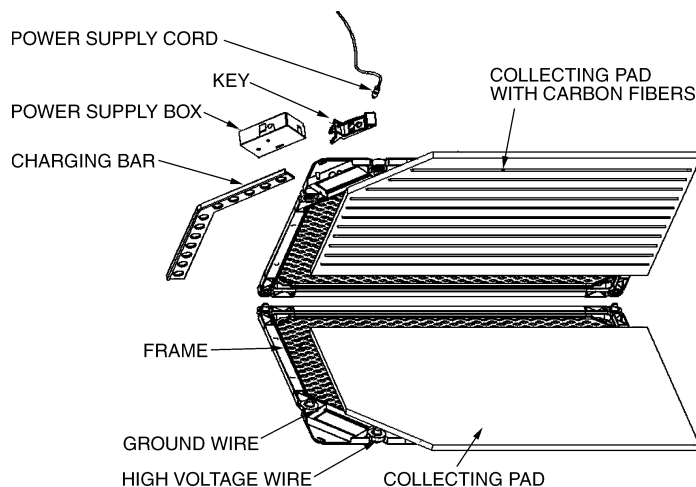

Fig. 1 — Electronic Air Screen Components

Electronic Air Cleaner Installation — Perform the following to install the electronic air cleaner.

1. If a filter rack exists, remove the existing furnace filter. Thoroughly clean the blower compartment and ductwork where the electronic air cleaner is to be installed. If a filter rack does not exist, fabricate a filter rack using the location information provided in the Location section on this page.
2. Place electronic air cleaner in filter rack. Ensure that there is no air leakage.
3. Wire the power cord to a 24-V power source. See Fig. 2. Use a voltmeter to positively identify that the power source is a 24-V (maximum 30-V) source. A field-supplied 110-V to 24-V adapter or transformer may be used to provide 24-V power. Ensure that the electronic air cleaner is properly grounded.

NOTE: If one terminal of the power source is grounded, connect the white striped wire of the power cord to this terminal.

⚠ CAUTION

Connecting the electronic air cleaner to a higher voltage power supply will cause damage to the electrical components of the electronic air cleaner. Do not connect to any power source higher than 30-V.

4. Route the power cord to the electronic air cleaner installation location. Plug the power cord into the high voltage power supply box of the electronic air cleaner. When power is provided to the electronic air cleaner, the green high voltage power supply light will be on.

OPERATION

To verify operation, check the high voltage power supply light on the power supply box. The green light should be on at all times when the power cord is plugged in. When the collecting pads need to be replaced, the orange light on the power supply box will be lit. Refer to the Collecting Pad Replacement section on this page.

For maximum performance of the electronic air cleaner, these steps should be followed:

- run your heating/cooling system fan continuously
- remove furniture or carpets which block return air grilles throughout your house, so that air moves freely to the furnace
- check for proper operation of the blower fan on the furnace
- ensure that the air cleaner is not clogged.

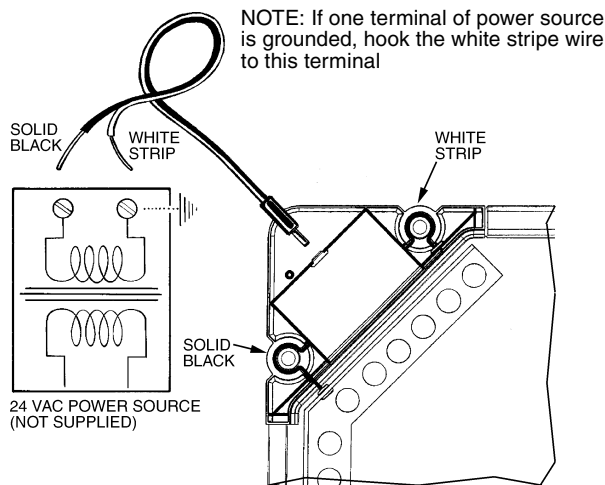

Fig. 2 — Electronic Air Cleaner Wiring

After installation of the electronic air cleaner, you may notice some white dust on table tops and shelves. Most heavy particles (such as lint) settle quickly and do not get filtered through the electronic air cleaner. To reduce lint and dust, use continuous fan operation and keep return vents unrestricted to create an efficient airflow.

MAINTENANCE

It is very important that the scheduled maintenance be done by the home owner. If the collecting pads are not changed on a regular basis, the electronic air cleaner will not operate effectively.

⚠ CAUTION

Injury or electric shock could result. Make sure to turn furnace off before performing any maintenance or removing any components. Unplug power supply cord from electronic air cleaner before removing from filter rack.

Collecting Pad Replacement — The collecting pads will need to be replaced 3 to 4 times a year, depending on the amount of contaminants in the air. If the collecting pads or mesh screens become clogged, airflow through the system may be restricted. This may cause service problems with the furnace or air conditioner. Check the orange plugged filter indicator light on the electronic air cleaner.

To replace the collecting pads:

1. Turn off furnace fan.
2. Disconnect power cord from the electronic air cleaner. See Fig. 3.
3. Remove electronic air cleaner from filter rack. See Fig. 4.
4. Lay the electronic air cleaner down. Open up the frames so the collecting pads are exposed. See Fig. 5.
NOTE: If required, use the key to open the 5 corner fasteners on the electronic air cleaner frames. See Fig. 6.
5. Remove the power bar. Remove and discard both collecting pads. See Fig. 5.
6. Vacuum the outside screens to remove all dust and residue. See Fig. 7. The outside screens can be washed with warm soapy water if needed. Be sure to dry screens thoroughly before re-installing electronic air collecting pads.
7. Install new collecting pads. Place power bar over collecting pad with carbon fibers. The power bar must be in contact with the carbon fiber collecting pad in order for the electronic air cleaner to operate correctly. See Fig. 8. Never wash the collecting pads.
8. Close the electronic air cleaner frames together and lock all 5 corner fasteners (if required). Make sure all the components are properly placed.
9. Place the electronic air cleaner back in the filter rack. See Fig. 9.

⚠ CAUTION

Make sure electronic air cleaner is completely dry before re-installing and turning on power. Damage to electronic air cleaner could result.

10. Re-connect the power cord to the electronic air cleaner. Check that green power supply LED is lit.
11. Turn on furnace fan.

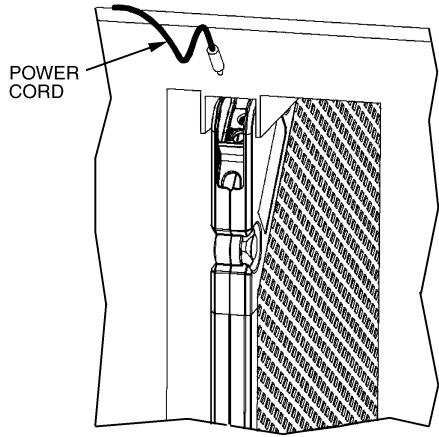

Fig. 3 — Power Cord Removal

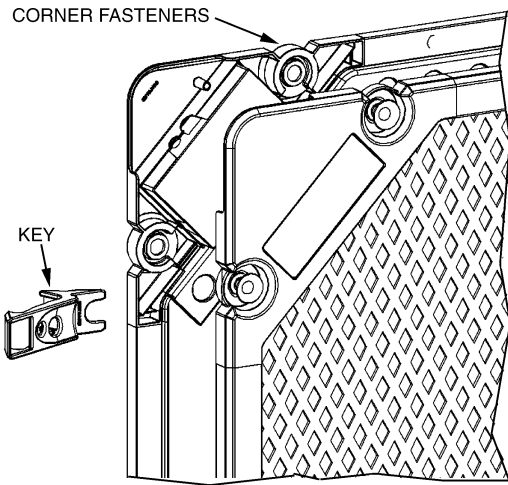

Fig. 6 — Opening Corner Fasteners with Key

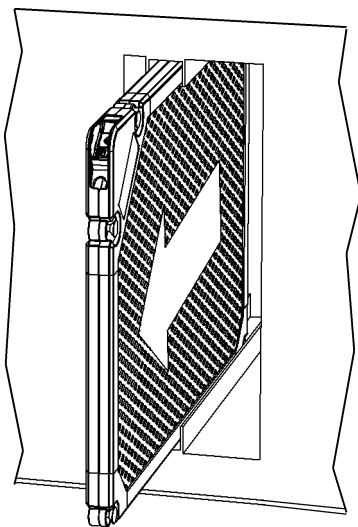

Fig. 4 — Electronic Air Cleaner Removal

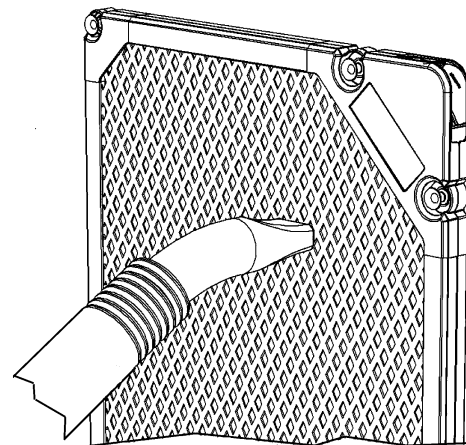

Fig. 7 — Vacuum Outer Screens

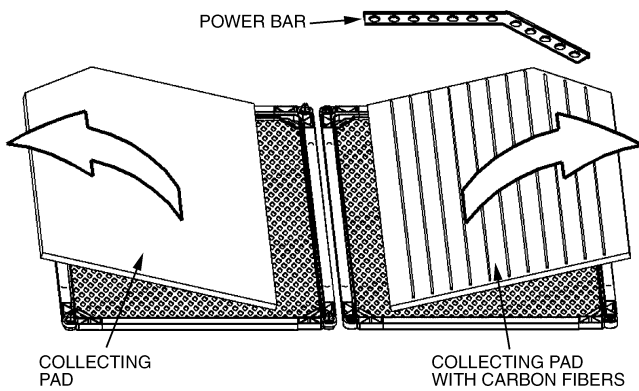

Fig. 5 — Collecting Pad Removal

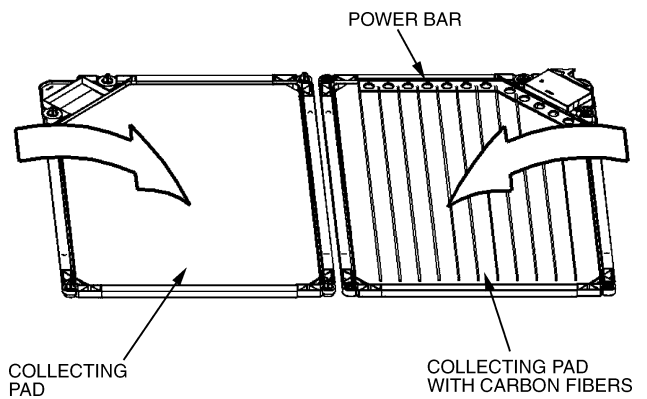

Fig. 8 — Install Replacement Collecting Pads

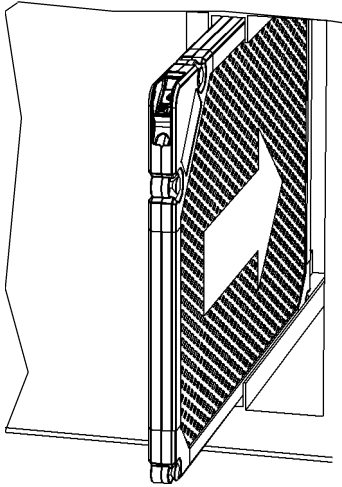

Fig. 9 — Replacing Electronic Air Filter

TROUBLESHOOTING

If the electronic air cleaner stops operating, verify that the green high voltage power supply light is on. If the light is off, check wiring and power supply. Make sure that the power cord is plugged in and connected to the power supply.

If the orange LED light is on, perform the Collecting Pad Replacement procedure in the section on page 3. Make sure power bar is properly placed and is in contact with the carbon fiber collecting pad.

**ELECTRONIC AIR CLEANER
LIMITED TWO-YEAR WARRANTY**

LIMITED TWO-YEAR WARRANTY — This CARRIER CORPORATION product is warranted to be free from defects in material and workmanship under normal use and maintenance for two years. The warranty does not apply to replacement of the disposable media collecting pads, which will need to be replaced three or four times a year depending on usage. A new or remanufactured part to replace the defective part will be provided without charge for the part itself, through a qualified servicing CARRIER CORPORATION dealer or service PROVIDED the defective part is returned to our distributor.

THIS WARRANTY DOES NOT INCLUDE ANY ADDITIONAL LABOR ALLOWANCE, or other costs incurred for diagnosis, repairing, removing, installing, shipping, servicing, or handling of either defective parts or replacement parts. SUCH COSTS MAY BE COVERED BY a separate warranty provided by the installer.

LIMITATIONS OF WARRANTIES — ALL IMPLIED WARRANTIES (INCLUDING IMPLIED WARRANTIES OF MERCHANTABILITY) ARE HEREBY LIMITED IN DURATION TO THE PERIOD FOR WHICH THE LIMITED WARRANTY IS GIVEN. THE EXPRESSED WARRANTIES MADE IN THIS WARRANTY ARE EXCLUSIVE AND MAY NOT BE ALTERED, ENLARGED, OR CHANGED BY ANY DISTRIBUTOR, DEALER, OR OTHER PERSON WHATSOEVER.

ALL WORK UNDER THE TERMS OF THIS WARRANTY SHALL BE PERFORMED DURING NORMAL WORKING HOURS. ALL REPLACEMENT PARTS, WHETHER NEW OR REMANUFACTURED, ASSUME AS THEIR WARRANTY PERIOD ONLY THE REMAINING TIME PERIOD OF THIS WARRANTY.

CARRIER WILL NOT BE RESPONSIBLE FOR:

1. Normal maintenance as outlined in the installation instructions including replacement of media collecting pads.
2. Damage or repairs required as a consequence of faulty installation or application by others.
3. Damage or repair needed as a consequence of any misapplication, abuse, improper servicing, unauthorized alteration or improper operations.
4. Damage as a result of floods, winds, fires, lightning, accidents, corrosive atmosphere, or other conditions beyond the control of CARRIER CORPORATION.
5. Parts not supplied or designated by CARRIER CORPORATION.
6. CARRIER CORPORATION products installed outside the continental U.S.A., Alaska, Hawaii and Canada.
7. ANY SPECIAL INDIRECT OR CONSEQUENTIAL PROPERTY OR COMMERCIAL DAMAGE OF ANY NATURE WHATSOEVER. Some states do not allow the exclusion of incidental or consequential damages, so the above limitation may not apply to you.

Model No. _____ Unit Serial No. _____

Date of Installation _____ Installed by _____

Name of Owner _____ Address of Installation _____

TOTALINE®

Star

Your Assurance of Quality

This Totaline® product is backed with a two-year warranty by Carrier Corporation, the world's largest manufacturer of air conditioning, heating, and refrigeration products.