



Installation Instructions



Designed and Assembled
in the USA.



A13408

Universal Application Programmable Thermostat

NOTE: Read the entire instruction manual before starting the installation.

TABLE OF CONTENTS

	PAGE
SAFETY CONSIDERATIONS	1
INTRODUCTION	1
INSTALLATION CONSIDERATIONS	1
INSTALLATION	2
Step 1 — Thermostat Location	2
Step 2 — Install Thermostat	2
Step 3 — Set Thermostat Configuration	2
Step 4 — Thermostat Operation	3
Step 5 — Check Thermostat Operation	3
WIRING DIAGRAMS	4

SAFETY CONSIDERATIONS

Improper installation, adjustment, alteration, service, maintenance, or use can cause explosion, fire, electrical shock, or other conditions which may cause death, personal injury, or property damage. Consult a qualified installer, service agency, or your distributor or branch for information or assistance. The qualified installer or agency must use factory-authorized kits or accessories when modifying this product. Refer to the individual instructions packaged with the kits or accessories when installing.

Follow all safety codes. Wear safety glasses, protective clothing, and work gloves. Have a fire extinguisher available. Read these instructions thoroughly and follow all warnings or cautions included in literature and attached to the unit. Consult local building codes and the current editions of the National Electrical Code (NEC) NFPA 70.

In Canada, refer to the current editions of the Canadian Electrical Code CSA C22.1.

Recognize safety information. This is the safety-alert symbol . When you see this symbol on the unit and in the instructions or manuals, be alert to the potential for personal injury.

Understand the signal words **DANGER**, **WARNING**, and **CAUTION**. These words are used with the safety-alert symbol. **DANGER** identifies the most serious hazards which **will** result in severe personal injury or death. **WARNING** signifies a hazard which **could** result in personal injury or death. **CAUTION** is used to identify unsafe practices which **may** result in minor personal injury or product and property damage. **NOTE** is used to highlight suggestions which **will** result in enhanced installation, reliability, or operation.

INTRODUCTION

The TOTALINE Universal Application programmable thermostat can be configured for both AC and HP applications. Both modes are dual-powered, operating from either 24VAC or two alkaline AA batteries. Configuration and program schedules are stored in non-volatile memory, preserving this information during power loss and battery removal. Features include simplified 5/2 programming, large backlit display, and modern styling.

When AC application is selected, one stage of heating and one stage of cooling are provided.

When HP application is selected, two stages of heating and one stage of cooling are provided.

INSTALLATION CONSIDERATIONS

The P710U-21PHP, whether configured for A/C or HP application, may be wired with or without connecting a common wire between the indoor equipment and the thermostat. However, it is recommended to use a common wire whenever possible.

Without a common wire, batteries must be installed. However, battery power will be supplemented by "power stealing."

This means the thermostat will steal a small amount of power from the equipment to which it is connected. This will also keep it powered while changing the batteries.

NOTE: Not all HVAC equipment is compatible with power-stealing type thermostats. Consult the system equipment Installation Instructions before applying this thermostat in a power stealing manner.

If both batteries and 24VAC operation are used (batteries installed and the common wire connected), indefinite clock operation is provided. The battery will be used only during AC power loss, preserving battery life.

INSTALLATION

Step 1 — Thermostat Location

Thermostat should be mounted:

- Approximately 5 ft (1.5m) from floor.
- Close to or in a frequently used room, preferably on an inside partitioning wall.
- On a section of wall without pipes or duct work.

Thermostat should NOT be mounted:

- Close to a window, on an outside wall, or next to a door leading to the outside.
- Exposed to direct light and heat from the sun, a lamp, fireplace, or other heat-radiating object which may cause a false reading.
- Close to or in direct airflow from supply registers and return-air grilles.
- In areas with poor air circulation, such as behind a door or in an alcove.

Step 2 — Install Thermostat

IMPORTANT: Install batteries last to ensure proper thermostat mounting and latch engagement.

WARNING

ELECTRICAL SHOCK HAZARD

Failure to follow this warning could result in personal injury or death.

Before installing thermostat, turn off all power to unit. There may be more than one disconnect.

1. Turn OFF all power to unit.
2. If an existing thermostat is being replaced:
 - a. Remove existing thermostat from wall.
 - b. Disconnect wires from existing thermostat, one at a time. Be careful not to allow wires to fall back into wall.
 - c. As each wire is disconnected, record wire color and terminal marking.
 - d. Discard or recycle old thermostat.

CAUTION

ENVIRONMENTAL HAZARD

Failure to follow this caution may result in environmental damage.

Mercury is a hazardous waste. Federal regulations require that mercury be disposed of properly.

3. Separate front and back (mounting base) assembly of thermostat.
4. Route thermostat wires through hole in mounting base. Level mounting base against wall (for aesthetic value and optimum air flow, the thermostat need not be level for proper operation) and mark wall through 2 of the available mounting holes.
5. Drill two 3/16-in. (5 mm) mounting holes in wall where marked.
6. Secure mounting base to wall with 2 anchors and screws provided, making sure all wires extend through hole in plastic.

NOTE: Anchoring the mounting base will ensure proper mounting and allow latch to fully engage.

7. Strip 1/4 in. insulation from thermostat wire and adjust length to reach terminal block connector on mounting base. Match and connect wires to proper terminal location in accordance with wiring diagrams.
8. Push any excess wire back into wall. Seal hole in wall to prevent air leaks. Leaks can affect thermostat operation. Any excess wire left inside thermostat casing may also affect thermostat operation by interfering with airflow across the temperature sensor.
9. Locate jumper marked J2 on circuit board. If common (C) wire has been connected, put J2 in the "24VAC" position. If no common wire leave J2 in the default "BATT" position.
10. Set the thermostat front housing into the (2) notches on the bottom of the mounting plate.
11. Rotate the front housing forward and snap into place, making sure terminal block connector aligns and assembly is secure.
12. Remove the branded faceplate and insert batteries provided.
13. Replace branded faceplate.
14. Turn ON power to unit.

On power up, the LCD readout will display AC, as this is the default equipment type.

Step 3 — Set Thermostat Configuration

Configuration options enable the installer to configure the thermostat for a particular installation.

These selections are intended to be made at installation and normally are not modified by the homeowner. Below is a list of available options followed by a description of each one.

Option 01 - Equipment type

Option 03 - Fahrenheit/Centigrade operation

Option 04 - Enable fan (G) on with heat W output

Option 10 -O (reversing valve) On with Heat or cool (present only when configured for HP applications)

Option 13 - Room air temperature offset adjustment

Option 15 -Auto Changeover. "OF" means AUTO Mode is off. "ON" means AUTO MODE is on. Default = OF.

Option 21 - Keypad Lockout

Option 26 - Minimum Cooling Setpoint

Option 27 - Maximum Heating Setpoint

To Enter The Configuration Mode:

Press and hold the FAN key for about 10 seconds until the display changes so that only two pairs of digits are showing. The configuration number, now 01, will appear in the setpoint/temperature location and the configuration setting will appear in the clock location. The configuration number (left pair) will be flashing which means it can be adjusted using the UP and DOWN keys. To cause the opposite pair to flash (to be adjustable), press the MODE key. Successive presses of the MODE key alternate between the configuration number (left) and the configuration setting (right). To exit the configuration mode, press the HOLD/END key. If no key is pressed for 3 minutes, the configuration mode will automatically exit, returning the thermostat to normal operation.

Option 01 - Equipment type

Selections: HP, AC, PH, or PC

Meanings:

PH or PC selects PTAC units (Packaged Terminal Air Conditioners) which are used in motel rooms and other rented spaces. When this option is selected, the display shows only the setpoint, not the room temperature. Also, the compressor timeguard is disabled, allowing the compressor to turn on immediately when a demand is established.

HP or PH controls 1 speed heat pump with 1 stage of aux heat.
AC or PC controls 1 speed air conditioner with one stage of heat.

Option 03 - Fahrenheit/Centigrade

This selection operates the thermostat in either Fahrenheit or Centigrade.

Selections: F = Fahrenheit — This is default.
C = Centigrade.

Option 04 - G (fan) ON with W (Heat) Selection

Selections: OF = G not energized with W — This is default.
ON = G energized with W.

This selection determines whether the fan (G) is to be ON or OFF when W (furnace or strip heat) is ON. Furnaces and fan coils which manage their own blowers do not require a separate G signal. Some auxiliary heaters require a separate G signal to operate the blower when W is applied.

Option 10 - Reversing valve

Applies only when configured for HP application.

Selections: C = reversing valve energized in cooling — This is default.
H = reversing valve energized in heating

Option 13 - Room Air Temperature Offset

Selections: $\pm 5^{\circ}\text{F}/\pm 3^{\circ}\text{C}$. Default is 0.

The number of degrees to be added to the displayed temperature to calibrate or deliberately miscalibrate the measured room temperature. The selected number is the number of degrees, plus or minus, which will be added to actual temperature. This option is in $^{\circ}\text{F}$ even if Option 3 is set for $^{\circ}\text{C}$.

Option 15 - Auto Changeover

Selections: ON, OF — Default is OF.

The heat setpoint and cool setpoint are separated by a minimum of 2 degrees. This feature allows the thermostat to automatically change between heating and cooling mode when a demand has been present in the opposite mode for a period of 20 minutes.

Manually changing either the cooling or the heating setpoint will allow an auto changeover to occur without the 20 minute time constraint.

Option 21 - Keypad Lockout

Selections: ON, OF — Default is OF.

With OF selected, the keypad cannot be locked. With ON selected the keypad will lock after 3 min of inactivity. When locked, any key press will result in "OF" being displayed on the screen to indicate that manual input is not allowed. To unlock press the UP and DOWN keys simultaneously for 5 seconds. Once unlocked, it will re-lock 3 minutes after the last key press.

Option 26 - Minimum Cooling Setpoint

Selections: 52° to $90^{\circ}\text{F}/11^{\circ}$ to 32°C — Default is $52^{\circ}\text{F}/11^{\circ}\text{C}$.

Sets the lowest cooling setpoint available to the user.

Option 27 - Maximum Heating Setpoint

Selections: 50° to $88^{\circ}\text{F}/10^{\circ}$ to 31°C — Default is $88^{\circ}\text{F}/31^{\circ}\text{C}$.

Sets the highest heating setpoint available to the user.

Step 4 — Thermostat Operation

Temperature Display

Thermostat will display room temperature until UP or DOWN button is pressed. The words SET TEMP appear when these buttons are pressed, and the current setpoint is displayed. If no buttons are pressed for 5 seconds, the display will change back to show room temperature.

Backlighting

Continuous backlighting is not available. The backlight will come on for 10 seconds after any button press. Without AC power and when the battery is low, the backlight will remain off with button presses.

Battery Indicator

A battery indication icon on the display shows nothing, half, or low/no battery condition. If the battery is full or operation is from AC power, no icon appears. Under battery operation, if the battery is half full, a half full battery icon appears. As the battery depletes below half, the icon remains at half, but the 10 second backlight disappears. When the battery is absent or depleted, the display goes blank except for an empty battery icon and all outputs are turned off.

Timeguard Timer

A 5-minute timeguard is built into the thermostat immediately upon power-up, and any time the compressor turns off. The compressor will not turn on until the timeguard has expired. The timeguard affects only compressor operation. Pressing UP and FAN buttons simultaneously will override the timeguard for 1 cycle. With PH or PC selected under Option 1, this timer is defeated.

Cycle Timer

In normal heating and cooling operation the thermostat will not allow more than 4 equipment cycles per hour (or 1 cycle every 15 minutes). Both the Y and W outputs have a 15-minute timer that starts counting down when the output is turned on, (e.g., if Y output is turned on for 9 minutes and then satisfies, it cannot turn back on for another 6 minutes regardless of demand). However, pressing UP and FAN buttons simultaneously or changing the setpoint will override the timer for 1 cycle.

Minimum On Timer

Once the equipment has turned on, it will remain on for a minimum of 3 minutes regardless of demand. However, the equipment can turn off in less than 3 minutes if a change in setpoint or a change in mode occurs.

Staging Timer

If the thermostat is configured for a heat pump application, it has 2-stage heat capability. In normal operation there is a 15-minute delay between the first and second stages of heat. The Y output will energize first, then 15 minutes later, W is allowed to come on if the thermostat determines it is not satisfying the demand.

However, if the heating demand is greater than $5^{\circ}\text{F}/3^{\circ}\text{C}$, there will be only a 30-second delay before bringing on W.

Auxiliary Heat Indicator

When operating a heat pump and either auxiliary heat or emergency heat is active, the AUX HEAT icon will show on the LCD.

Error Messages

If the room temperature sensor fails, two dashes (--) will appear in the temperature display and all heating and cooling outputs will be turned off. The thermostat must be replaced.

If the internal non-volatile memory fails, E4 will alternately flash with the temperature on the display and all heating and cooling outputs will be turned off. The thermostat must be replaced.

Step 5 — Check Thermostat Operation

Fan Operation

1. Press FAN button. This will start continuous fan operation. FAN ON icon will turn on.
2. Press FAN button again. This will stop continuous fan operation. FAN ON icon will turn off.

Heating Operation

1. Press MODE button until HEAT is displayed.
2. Press UP button until LCD readout reads 3°F/2°C above room temperature. Press UP and FAN buttons simultaneously to defeat timers. Heating system should begin to operate immediately.
3. For HP applications only, press MODE button until EMHT (emergency heat) appears. Press UP and FAN buttons simultaneously to defeat timers. Emergency heating (W is ON, Y is OFF) should begin immediately.

Cooling Operation

1. Press MODE button until COOL is displayed.
2. Press DOWN button until LCD readout reads 3°F/2°C below room temperature. Press UP and FAN buttons simultaneously to defeat timers. Cooling system should begin to operate immediately.

Table 1 shows the thermostat outputs for each available stage of heating or cooling. It may be useful in checkout or troubleshooting.

Table 1 – Outputs

EQUIPMENT CONFIGURATION OPTION #1	COOL STAGE 1	HEAT STAGE 1	HEAT STAGE 2	EM HEAT
AC, PC	Y, G	W	--	--
HP, PH RVS = C	Y, G, O/B	Y, G	Y, G, W	W
HP, PH RVS = H	Y,G	Y, G, O/B	Y, G, W, O/B	W

WIRING DIAGRAMS

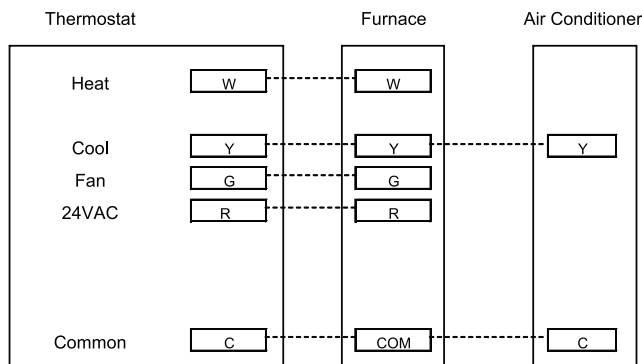

A06566

Fig. 1 - A/C Thermostat Typical Installation

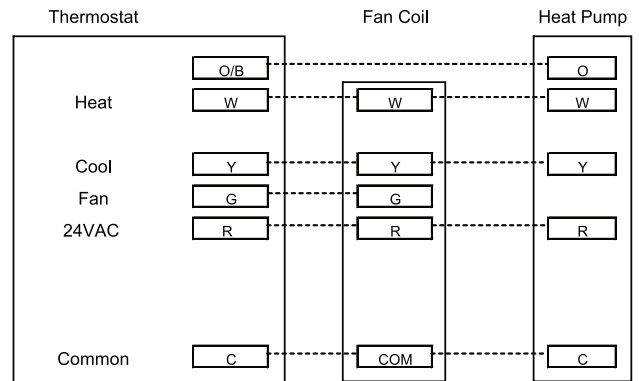

A06567

Fig. 2 - HP Thermostat Typical Installation



Homeowner's Guide



Designed and Assembled
in the USA.



A13408

Universal Application Programmable Thermostat

SETTING TIME AND DAY

At Power-Up

When power is first applied, AC or HP will appear for 5 seconds to indicate whether it is setup as an air conditioner (AC) or a heat pump (HP) model. After this, the time display will flash to tell you the power has been off.

Setting The Current Time:

1. Press the TEMP/TIME button. SET TIME flashes on the display.
2. Press the UP or DOWN button until the correct time is displayed.
3. To quickly advance to the proper time, press and hold the UP or DOWN button.
4. When the correct time appears on the display, press the HOLD/END button.

NOTE: If you choose not to press the HOLD/END button, the thermostat will automatically exit the time setting mode after 10 seconds.

Setting The Current Day:

1. Press the DAY button to advance to the correct day.
2. When the correct day appears on the display, press the HOLD/END button.

MANUAL OPERATION

To Operate Manually (Without the Programmed Comfort Schedule):

Press the HOLD/END button to make the HOLD icon appear. Then follow the four steps below:

- 1. To Select the Mode:**
Use the MODE button to move between the choices. OFF, HEAT, AUTO (if enabled), COOL, or EMHT will appear on the display. EMHT will only appear when setup for heat pump application.
- 2. To Select the Fan Operation:**
Use the FAN button to move between continuous fan (indicated by the FAN ON icon) and auto fan operation.
- 3. To Read the Room Temperature:**
The large display reads room temperature until a button is pressed.
- 4. To Adjust the Setpoint:**
In normal operation, the large display shows room temperature. At the first press of the UP or DOWN button, the large display shows the current setpoint and the SET TEMP icon is turned on. Further presses of the UP or DOWN button adjust the setpoint upward or downward. Five seconds after the last button press, the display returns to the room temperature and the SET TEMP icon turns off.

PROGRAMMED OPERATION

Introduction

The Universal Application Programmable Thermostat provides four periods per day (MORN, DAY, EVE, NIGHT) and two schedules per week (MoTuWeThFr and SaSu). A separate time, heat setpoint, and cool setpoint can be set for each period and schedule. Before starting to actually program the thermostat, fill out Table 1 with the values you wish to program. (The factory default time and temperature values are already programmed for you as a starting point and are shown in Table 1.)

The first press of the SET button brings up the programming mode and places you at morning (MORN) of the MoTuWeThFr schedule. Successive presses move you between the four daily periods.

While Programming:

The TEMP/TIME button moves between three selections of SET TIME, SET TEMP & HEAT, and SET TEMP & COOL. These three numbers are to be programmed for each of the periods MORN, DAY, EVE, and NIGHT.

The DAY button moves between the weekdays (MoTuWeThFr) and the weekend (SaSu) selections. A different schedule may be set for the weekdays and the weekend. You may exit programming at any time by pressing the HOLD/END button.

Programming A Weekly Comfort Schedule:

1. Press the SET button. The word PROGR appears on the display and the words SET TIME flash on the display. The MoTuWeThFr and MORN period icons will appear on the display. The current mode HEAT will also show.
2. Press the UP or DOWN button to set the start time for MORN (1) value in Table 1).
3. Press TEMP/TIME. The words SET TEMP will flash. Use the UP and DOWN buttons to select the heat setpoint.
4. Press TEMP/TIME. The word COOL will appear and SET TEMP continues to flash on the display. Use the UP and DOWN buttons to select the cool setpoint.
5. Press the SET button to advance to the next time period. Press TEMP/TIME. Enter time and temperature settings (4) through 12) in Table 1) for the periods DAY, EVE, and NIGHT by following items 2-4 above.
6. Press the DAY button to change between weekday and weekend programming. To set the weekend schedule, repeat items 2 through 5, entering values in 13) through 24) in Table 1.
7. Press HOLD/END to exit the programming mode.

Modifying Your Weekly Comfort Schedule

If you choose to change any of your weekly schedule, press SET at any time. You will enter the programming schedule with weekdays morning period.

You are ready to set the new starting time for the morning period. One press of the TEMP/TIME button and you are ready to set the new morning temperature. To set values for other periods, use the SET button. To set values for other days, use the DAY button. Press HOLD/END and you are finished.

Overriding Your Comfort Schedule

There are two ways to override your comfort schedule.

Method 1 — Manual Operation

By pressing the HOLD/END button to turn on the HOLD icon, the thermostat will maintain the current temperature settings and ignore the comfort schedule for an indefinite period of time. The word HOLD will appear in the display. Press the HOLD/END button a second time and the thermostat will return the temperature settings to the programmed comfort schedule. Pressing HOLD/END will not alter your programmed comfort schedule.

Method 2 — Temporary Override

At the first press of the UP or DOWN button, the current temperature setting will appear on the display. Pressing the UP or DOWN button again will temporarily change the setpoint as needed. At the next programmed time, the programmed comfort schedule will resume.

KEY PAD LOCK OUT FEATURE

At installation and setup of your thermostat the keypad lockout feature can be enabled. This feature when enabled, locks the keypad. If any key is pressed and the thermostat is locked, “Loc” will be displayed in the clock digits to indicate that manual input is not allowed. It can be temporarily unlocked by simultaneously pressing the UP and DOWN keys for 5 seconds. Once unlocked, it will re-lock 3 minutes after the last keypad press.

AUXILIARY AND EMERGENCY HEAT

Auxiliary Heat

If the system has determined that it's too cold outside for your heat pump to heat the house without help, the AUX HEAT icon will indicate that the system is getting help from the electric heaters. This happens automatically.

Emergency Heat (EMHT)

If the heat pump is not working properly, you can manually turn on the emergency heat by pressing MODE until EMHT appears.

You'll know there's a problem if the house can't seem to get warm when it's cold outside. You want to avoid using emergency heat continuously, though, because it's the most expensive option. If you suspect a problem with your heat pump, call your heating and cooling dealer immediately.

CHANGING BATTERIES

In some situations, two AA batteries are the power source for the thermostat. If batteries are used with your equipment, then they should last about one year. As the batteries lose their power, a battery icon appears on the display showing one black bar and then none. As the icon becomes empty, you will begin to lose thermostat functions because the batteries are losing their power. When the batteries are completely dead, you won't be able to use the thermostat.

When using batteries for power, we recommend you replace them with two AA alkaline batteries. They are in a compartment under the removable faceplate of the thermostat. ***You do not have to remove the thermostat from the wall to replace the batteries***

Simply use your thumb and forefinger to grasp and pull the branded faceplate away from the thermostat to expose the batteries. Lift out the batteries, and replace them.

Be sure to orient batteries in the direction indicated by the embossed symbols shown on the plastic.



A13409



A14201

Table 1 – Programming Table

FACTORY DEFAULT VALUES				NEW COMFORT SCHEDULE					
PERIOD	TIME	COOL	HEAT	MoTuWe ThFr TIME	COOL	HEAT	SaSu TIME	COOL	HEAT
MORNING	6:00 A.M.	78°F 26°C	68°F 20°C	1)	2)	3)	13)	14)	15)
DAY	8:00 A.M.	85°F 29°C	60°F 16°C	4)	5)	6)	16)	17)	18)
EVE	5:00 P.M.	78°F 26°C	68°F 20°C	7)	8)	9)	19)	20)	21)
NIGHT	10:00 P.M.	82°F 28°C	60°F 16°C	10)	11)	12)	22)	23)	24)

THERMOSTAT LIMITED WARRANTY



FIVE YEAR WARRANTY

CARRIER CORPORATION (hereinafter “Company”) warrants this product against failure due to defect in materials or workmanship under normal use and maintenance as follows. All warranty periods begin on the date of original installation. If a part fails due to defect during the applicable warranty period Company will provide a new or remanufactured part, at Company’s option, to replace the failed defective part at no charge for the part. Alternatively, and at its option, the Company will allow a credit in the amount of the then factory selling price for a new equivalent part toward the retail purchase price of a new Company product. Except as otherwise stated herein, those are Company’s exclusive obligations under this warranty for a product failure. This limited warranty is subject to all provisions, conditions, limitations and exclusions listed below and on the reverse (if any) of this document.

OWNER-OCCUPIED, RESIDENTIAL APPLICATIONS

This warranty is to the original purchasing owner and is transferable only to the extent and as stated in the Warranty Conditions. The warranty period is five (5) years and is not transferable.

WARRANTY CONDITIONS:

1. Where a product is installed in a newly constructed home, the date of installation is the date the homeowner purchased the home from the builder.
2. If the date of original installation cannot be verified, then the warranty period begins ninety (90) days from the date of product manufacture (as indicated by the model and serial number). Proof of purchase may be required at time of service.
3. Product must be installed properly and by a licensed HVAC technician.
4. The warranty applies only to products remaining in their original installation location.
5. Installation, use, care, and maintenance must be normal and in accordance with instructions contained in the Installation Instructions, Owner’s Manual and Company’s service information.
6. Defective parts must be returned to the distributor through a registered servicing dealer for credit.

THERMOSTAT LIMITED WARRANTY

THIS WARRANTY DOES NOT INCLUDE ANY ADDITIONAL LABOR ALLOWANCE OR OTHER COSTS incurred for diagnosis, repairing, removing, installing, shipping, servicing or handling of either defective parts or replacement parts. **SUCH COSTS MAY BE COVERED BY** a separate warranty provided by the installer.

LIMITATIONS OF WARRANTIES: ALL IMPLIED WARRANTIES (INCLUDING IMPLIED WARRANTIES OF MERCHANTABILITY) ARE HEREBY LIMITED IN DURATION TO THE PERIOD FOR WHICH THE LIMITED WARRANTY IS GIVEN. THE EXPRESSED WARRANTIES MADE IN THIS WARRANTY ARE EXCLUSIVE AND MAY NOT BE ALTERED, ENLARGED, OR CHANGED BY ANY DISTRIBUTOR, DEALER, SERVICE PROVIDER OR OTHER PERSON WHATSOEVER.

CARRIER WILL NOT BE RESPONSIBLE FOR:

1. Normal maintenance as outlined in the installation and servicing instructions or owner’s manual, including filter cleaning and/or replacement and lubrication.
2. Damage or repairs required as a consequence of faulty installation or application by others.
3. Failure to start due to voltage conditions, blown fuses, open circuit breakers or other damages due to the inadequacy or interruption of electrical service.
4. Damage or repairs needed as a consequence of any misapplication, abuse, improper servicing, unauthorized alteration, or improper operations.
5. Damage as a result of floods, winds, fires, lightning, accidents corrosive atmosphere, or other conditions beyond the control of CARRIER CORPORATION.
6. Parts not supplied or designated by CARRIER CORPORATION.
7. CARRIER CORPORATION products installed outside the continental U.S.A., Alaska, Hawaii and Canada.
8. Electricity or fuel costs or increases in electricity or fuel costs from any reason whatsoever including additional or unusual use of supplemental heat.
9. Any product purchased over the Internet.
10. ANY SPECIAL INDIRECT OR CONSEQUENTIAL PROPERTY OR COMMERCIAL DAMAGE OF ANY NATURE WHATSOEVER. Some states do not allow the exclusion of incidental or consequential damages, so the above limitation may not apply to you.

THERMOSTAT LIMITED WARRANTY

Model Number _____ Serial Number _____
 Date of Installation _____ Installed by _____
 Name of Owner _____ Address of Installation _____

39004DP495

06/2012

