

TC - PHP01 - BLK
Carrier® Programmable Thermostat
Air Conditioner and Heat Pump
Applications



Installation Guide



A07051

INTRODUCTION

Welcome and from all of us at Carrier®, thank you for purchasing your new Carrier programmable thermostat. This thermostat is designed to be simple to install but it's best to review all of the instructions in this manual before you start to help ensure there are no surprises during installation.

If any questions arise during your installation, we're here to help:

- Visit www.carrier.com/homecomfort for how-to videos and answers to frequently asked questions.
- Technical support is also available by phone or email at:
 - 1.800.CARRIER or 1.800.227.7437
 - contact.carrier@carrier.utc.com
- The thermostat is also supported by the world's greatest network of professional contractors. Find an Expert Carrier Contractor at www.carrier.com/dealers

Let's get started!

COMPATIBLE HEATING AND COOLING SYSTEMS

This thermostat works with many centralized residential heating and cooling systems.

- Conventional Heating and Cooling (AC): up to one stage of heating and two stages of cooling
- Heat Pump (HP): up to three stages of heating and two stages of cooling
 - Heat pumps work to provide cooling in the summer but in the winter, they do it in reverse, drawing their heat energy from the outside air.
- Systems with a Common (C) wire
 - Recommended to whenever possible
- Systems without a Common (C) wire
 - Two alkaline AA batteries required



This thermostat is not compatible with Dual Fuel or Geothermal Systems. Review all documentation to ensure that you have selected the appropriate model thermostat for your system.

ITEMS INCLUDED IN THE BOX

- A. The Carrier® Programmable Thermostat
- B. Mounting screws and drywall plugs
- C. Installation Guide and Owner's Manual
- D. Batteries

A.

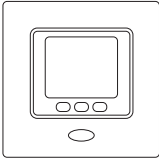

B.



C.



D.



A150216



Tip: Write down your thermostat serial number and save it for future reference. It is located on the thermostat circuit board next to the model number TP-PHP.

ITEMS YOU'LL NEED FOR INSTALLATION

- A. Pencil
- B. Phillips screwdriver
- C. Small flathead screwdriver
- D. Drill with a 3/16" drill bit

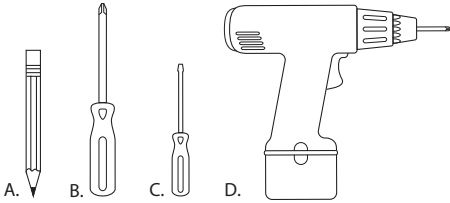

A150218



Tip: Review all the instructions before you start to help ensure that there are no surprises during installation

STEP 1. REMOVE THE COVER FROM YOUR OLD THERMOSTAT

1. Most covers snap off easily but some are attached by screws.
2. Note if either of the following apply to your old thermostat:
 - a. If you do not have a wire connected to C, two alkaline AA batteries are required.
 - b. If you have wires connected to Rh **and** Rc **and** C, you'll use two breakers or switches to disconnect power in Step 2.
3. If you find that you have additional wires labeled anything other than those shown in the diagram below – STOP and review to see if this model thermostat is compatible with your system

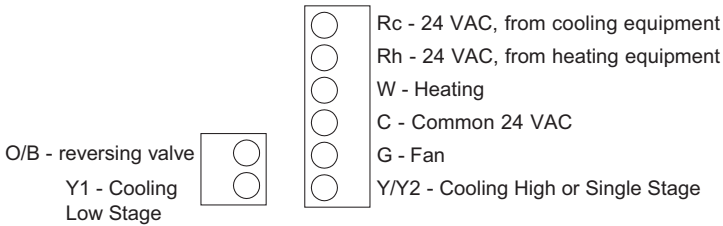

A09271

4. Reattach the cover of your old thermostat. You'll use it in Step 2 to confirm the power is disconnected.

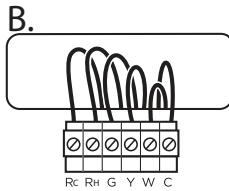
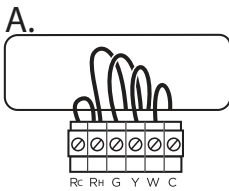

A150045



Warning! If your old thermostat is labeled 110V or 120V, or is connected by thick wires and wire nuts, it is a high voltage system and is not compatible

STEP 2. POWER OFF YOUR HEATING AND COOLING SYSTEM

1. Turn off the power to your heating and cooling system.
 - a. You can do this either at your circuit breaker box or a switch at your indoor furnace or fan coil.
 - b. Most systems have one switch, but some systems or systems with Rh and Rc and C wires noted in Step 1 will have two switches.
2. Make sure your system is without power by using your old thermostat to adjust the temperature. Your system should not turn on.

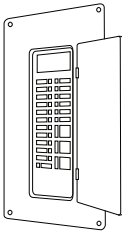

or



A150046



Warning! Electrical operation hazard. Failure to follow this warning could result in injury, death, or equipment damage

STEP 3. REMOVE YOUR OLD THERMOSTAT

1. Remove the cover of your old thermostat.
2. Using your old thermostat as a guide, record wire color and corresponding letter where it is connected on the thermostat terminal block. Don't worry about any non-connected wires.
3. Also note if there is a jumper wire or bracket between Rh, Rc, or R. If yes, you will need to jumper these terminals on your new thermostat as well.

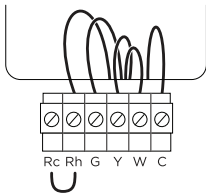

A150219

Wire Color	Connected to Terminal Letter
Green	G
There is a jumper wire or bracket between Rh, Rc, or R?	
Yes	No



Tip: Take a photo of your old thermostat wiring with your smartphone for reference later

4. Disconnect each wire. Most thermostat wires are connected using screws; simply loosen each screw with a small screwdriver. Be careful not to let any wires fall back into the wall.
5. Remove your old thermostat base by unscrewing it from the wall.

STEP 4. INSTALL YOUR CARRIER® THERMOSTAT

1. Separate front display and mounting back plate of thermostat by pressing the thumb release at the top of the thermostat and carefully snap apart.

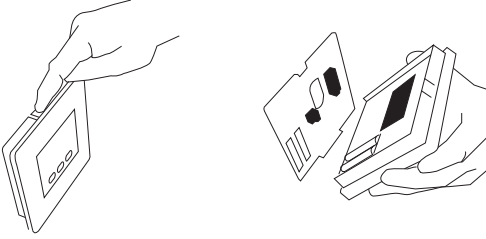

A150220

2. Gently pull the wires through the hole in the back plate.
3. Center the wires in the back plate.
4. Mark four mounting holes on the wall with a pencil.
5. Drill mounting holes on the pencil marks with a 3/16" drill bit.
6. Insert the plastic drywall anchors into the wall. Use the screws provided to secure the back plate to the wall.

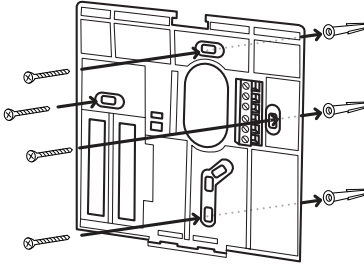

A150224

STEP 5. CONNECTING THE WIRES

1. Using the table you created on page 8, use a small screwdriver to loosen the screws then insert each wire into its matching connector block hole.
 - a. Insert only one wire in each connector.
 - b. Only connect wires that were connected to your old thermostat
 - c. If you need additional help with the wiring, refer to the terminal descriptions and wiring diagrams beginning on page 22.
2. After inserting a wire, tighten screw using a small screwdriver.

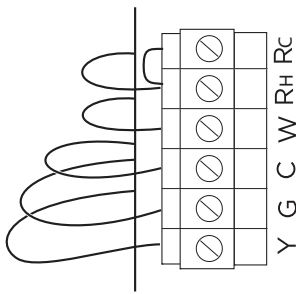

A150221

3. When all the wires are connected, gently push any excess wire back into the wall.

STEP 6. CONNECTING THE DISPLAY

1. With the Carrier® logo positioned at the bottom, attach thermostat display to back plate by inserting tab on bottom edge and hinging up until top snap secures.
2. Close thermostat assembly making sure pins on back of circuit board align with sockets in connector.
3. Now you can turn the power back on to your heating and cooling system. Return to your circuit breaker or on/off switch and restore the power to your system.
4. The thermostat will automatically power on.

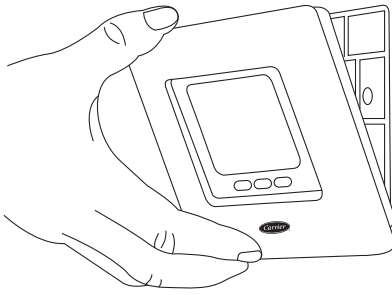

A150223

STEP 7. SET THERMOSTAT CONFIGURATION

When power is applied, all display icons are lit for 2 seconds to test the display.

Following this, the equipment type for which the thermostat is configured is displayed for an additional 2 seconds. It will be one of HP, H2, AC, A2, H or C. You may need to make an adjustment to this setting depending on the system you've connected. See explanation under Step 3, Option 01 below.

The remaining settings are preconfigured for the most common system type. To adjust the default configuration, you will need to enter Configuration Mode. A description of each configurable option is listed below.

To Enter The Configuration Mode:

1. Press and hold the FAN key for about 10 seconds until the display changes so that only two pairs of digits are showing.

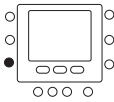

A150225

- a. The left display shows the configuration number.
 - b. The right shows the configuration setting.
2. The configuration number will be flashing which means it can be adjusted using the UP and DOWN keys.

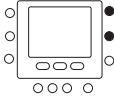

A150226

3. To cause the opposite pair to flash (to be adjustable), press the MODE key.

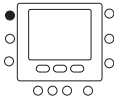

A150227

4. Successive presses of the MODE key alternate between the configuration number and the configuration setting.
5. To exit the configuration mode, press the FAN key.

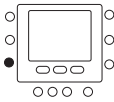

A150225

6. If no key is pressed for 3 minutes, the configuration mode will automatically exit, returning the thermostat to normal operation.

Option 01 - Equipment type

You may need to make an adjustment to this setting depending on the system you've connected. If you're unsure about your system type, refer to wiring diagrams beginning on page 23.

Options: HP, H2, AC, A2, H, C

Description:

- HP controls 1 speed heat pump with 1 stage of auxiliary heat.
- A2 controls two stages of cooling and one stage of furnace heat.
- H2 controls a 2 Speed HP with 1 stage of auxiliary heat.
- AC controls 1 speed air conditioner with 1 stage of heat.
- H operates a heat only system: furnace or fan coil only; no outdoor unit.
- C operates a cool only system: outdoor AC unit with an indoor fan coil; no strip heater support.

Option 03 - Fahrenheit/Centigrade

Default: Fahrenheit (F)

Selections: Fahrenheit (F), Centigrade (C)

Description: This selection operates the thermostat in either Fahrenheit or Centigrade.

Option 04 - G (fan) ON with W(Heat) Selection

Default: G not energized with W (OF)

Options: G not energized with W (OF), G energized with W (ON)

Description: This selection determines whether the fan (G) is to be ON or OFF when W (furnace or strip heat) is ON. Furnaces and fan coils which manage their own blowers do not require a separate G signal. Some auxiliary heaters require a separate G signal to operate the blower when W is applied.

Option 07 - Zoning

Default: Non-zoned system (OF)

Options: Non-zoned system (OF), Zoned system (ON)

Description: ON disables thermostat's internal timers which are not needed with zoning system controls. Must be set to OF for non-zoned systems.

Option 10 - Reversing Valve

Default: Reversing valve energized in cooling (C)

Options: Reversing valve energized in cooling (C), Reversing valve energized in heating (H)

Description: Applies only when configured for Heat Pump applications. Most systems use the orange (O) wire and are energized in cooling.

- Select Energized in Cooling (C) if you connected an (O) wire in the O/B terminal to activate the reversing valve output when there is a call for cooling.
- Select Energized in Heating (H) if you connected a (B) wire in the O/B terminal to activate the reversing valve output when there is a call for heating.

- If you are unsure, consult your heating and cooling system equipment installation instructions or contact Carrier customer support.

Option 11 - Minimum Deadband Between Heating And Cooling

Default: 02

Options: 01 through 06

Description: Sets the minimum allowable number of degrees between heating and cooling setpoints. One setpoint will “push” the other to maintain this difference.

Option 12 - Smart Recovery

Default: 90

Options: OF, 30, 60, 90

Description: The Smart Recovery feature transitions your home from one temperature period

(P1, P2, P3, P4) to the next so that your home’s temperature matches the temperature setting at the start of each time period. This means, for example, that if your sleep period temperature setting is lower than the period that precedes it, the thermostat will start cooling down the home before the beginning of the scheduled sleep period. It does this at an energy-efficient rate. This not only helps make your home as comfortable as possible, it also makes your thermostat more cost effective.

Smart Recovery OF means setpoints change immediately at a program schedule change. Thirty, 60, or 90 selects the number of minutes recovery starts before programmed recovery time. Recovery takes place smoothly during the selected recovery time, ending at the recovery time and temperature which is programmed. If the setpoint is changed during smart recovery, the smart recovery is cancelled and the new setpoint is effective immediately.

Option 13 - Room Air Temperature Offset

Default: 0°F

Options: - 5°F to 5°F

Description: The number of degrees to be added to the displayed temperature to calibrate the measured room temperature. The selected number is the number of degrees, plus or minus, which will be added to actual temperature. This option is in °F even if Option 03 is set for °C.

Option 15 - Auto Changeover

Default: Off (ON)

Options: On (ON), Off (OF)

Description: This feature allows the thermostat to automatically change between heating and cooling mode as demand requires. If disabled (OF), the thermostat maintains either heating or cooling mode only. Auto changeover is not available when H or C is selected under Option 01.

Option 16 - Maximum Cycles Per Hour

Default: 4

Options: 2, 4, or 6

Description: The maximum cycle rate is limited by internal timers to the selected number of cycles per hour. Selection of a higher number causes faster cycling resulting in more constant room temperature.

Option 17 - Minimum Time Between Equipment Stages

Default: 15

Options: 10, 15, 20, 25

Description: When there is an auxiliary stage of heat available, this is the amount of time the heat pump must operate before the auxiliary stage can turn on. With heat pumps, longer times can reduce the amount of auxiliary heat used.

Option 18 - Backlight Configuration

Default: OF

Options: On (ON), Off (OF)

Description: When ON is selected and the thermostat is not battery operated, a low level continuous display backlight is always on. With OF selected, the backlight is only on for a short time after the door is opened or a key is pressed. Continuous backlight is not available with battery operation.

Option 21 - Keypad Lockout

Default: Off (OF)

Options: On (ON), Off (OF)

Description: With OF selected, the keypad cannot be locked. With ON selected the keypad will be locked and can be unlocked by simultaneously pressing the UP and DOWN keys for 5 seconds. Once unlocked, it will re lock 2 minutes after the last keypad press. A "lock" icon is displayed while it is locked.

Option 24 - Programmable/Non-Programmable

Default: Programmable (P)

Options: Programmable (P), Non-programmable (nP)

Description: Enabling nP mode disables programming. The clock is displayed, but the program schedule, the HOLD and TEMPORARY HOLD functions are disabled.

Option 25 - Number of Programmable Periods

Default: 4

Options: 2, 4

Description: The number of programmable periods available in your schedule per day.

- Selecting 2 allows 2 programming periods per day, P1 and P2. For

example, a temperature setting when you're home and a different temperature setting when you sleep.

- Selecting 4 allows 4 programming periods per day, P1, P2, P3, and P4. For example, different temperature settings when you're waking up, away, at home, and sleeping.

Option 26 - Minimum Cooling Setpoint

Default: 52°F

Options: Between 52°F and 90°F

Description: Sets the lowest cooling setpoint available.

Option 27 - Maximum Heating Setpoint

Default: 88°F

Options: Between 50°F and 88°F

Description: Sets the highest heating setpoint available.

Option 99 - Reset to Factory Defaults

Use this capability to reset the thermostat to "out of the box" conditions.

When this option is selected, the configuration number (99), will appear on the left and 10 will appear on the right. To perform the reset, first use the MODE key to make the 10 flash. Then press and hold the DOWN key. The 10 will start counting down toward zero. If the DOWN key is kept pressed until the count reaches zero, the reset will be performed. If the DOWN key is released early, the number will return to 10 and the reset will not occur.

NOTE: All configuration settings, program settings, clock, and day which have been manually entered will be lost!

STEP 8. CHECK THERMOSTAT OPERATION

To finalize your installation, confirm your equipment is operating properly

Fan Operation

1. Press FAN button. This will start continuous fan operation. FAN ON icon will turn on.
2. Press FAN button again. This will stop continuous fan operation. FAN ON icon will turn off.

Heating Operation

1. Press MODE button until HEAT is displayed.
2. Press UP button until LCD readout reads 3°F/2°C above room temperature. Heating system should operate.
3. For Heat Pump (HP) applications only, press MODE button until EMHT (emergency heat) appears. Emergency heating should begin.

Cooling Operation

1. Press MODE button until COOL is displayed.
2. Press DOWN button until LCD readout reads 3°F/2°C below room temperature. Cooling system should begin to operate.

NOTE: the thermostat uses timers to protect your system from running heating or cooling cycles which are too short. Allow five minutes after cooling changes



Warning! To avoid possible compressor damage, do not run cooling if the outside temperature drops below 50°F (10°C).

Table 1 shows the thermostat outputs for each available stage of heating or cooling. It may be useful in troubleshooting.

Table 1 – Outputs

Equip Config	COOL STG 1	COOL STG 2	HEAT STG 1	HEAT STG 2	HEAT STG 3	EM HEAT
SS AC Opt 1 = AC	Y	--	W	--	--	--
SS HP Opt 1 = HP RVS = O Opt 10 = C	Y, O/B	--	Y	Y, W	--	W
SS HP Opt 1 = HP RVS = B Opt 10 = H	Y	--	Y, O/B	Y, W, O/B	--	W
2SPD AC Opt 1 = A2	Y1	Y1, Y	W	--	--	--
2SPD HP Opt 1 = H2 RVS = O Opt 10 = C	Y1, O/B	Y1, Y, O/B	Y1	Y1, Y	Y1, Y, W	W
2SPD HP Opt 1 = H2 RVS = B Opt 10 = H	Y1	Y1, Y	Y1, O/B	Y1, Y, O/B	Y1, Y, W, O/B	W
Heat Only Opt 1 = H	--	--	W	--	--	--
Cool Only Opt 1 = C	Y1	Y1,Y	--	--	--	--

TERMINAL DESIGNATIONS

O/B - reversing valve

Y1 - Cooling

Low Stage

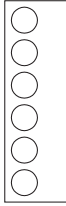

Rc - 24 VAC, from cooling equipment

Rh - 24 VAC, from heating equipment

W - Heating

C - Common 24 VAC

G - Fan

Y/Y2 - Cooling High or Single Stage

A09271

WIRING DIAGRAMS

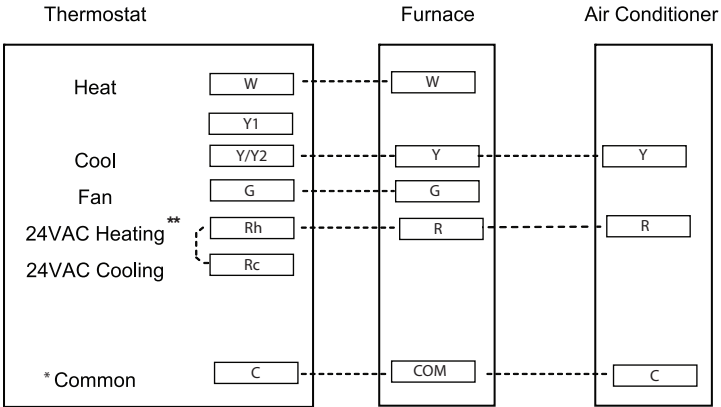

* C wire not needed for batteries

** Remove jumper when using split power (Indoor and Outdoor units utilize separate transformers).

A12246

Fig. 1 - Single Speed A/C Thermostat Typical Installation
Equipment configuration: AC

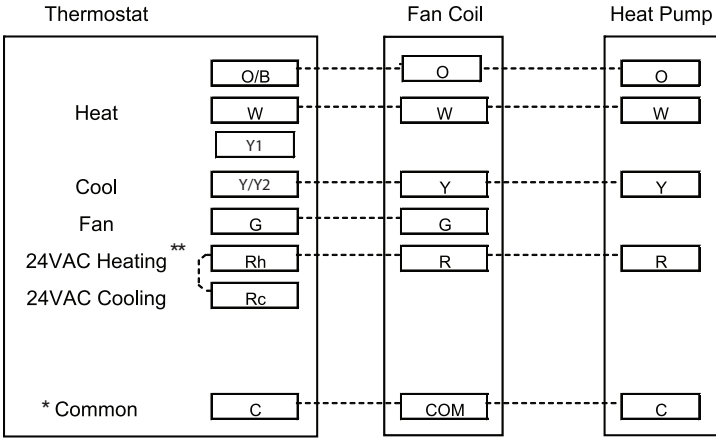

* C wire not needed for batteries

** Remove jumper when using split power (Indoor and Outdoor units utilize separate transformers).

A12238

Fig. 2 - Single Speed HP Thermostat Typical Installation
Equipment configuration: HP

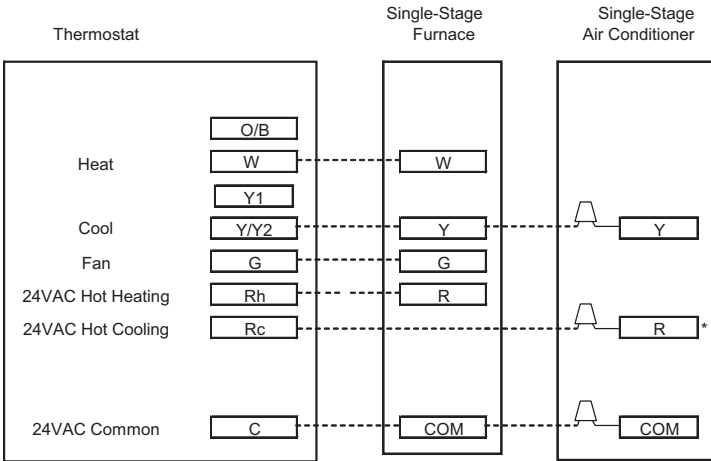

* Indicates connection may not be required/available.

A09246

Fig. 3 - Single-stage Furnace with Air Conditioner and Split Power
Equipment configuration: AC

NOTE: Rc/Rh jumper is cut or removed on the thermostat.

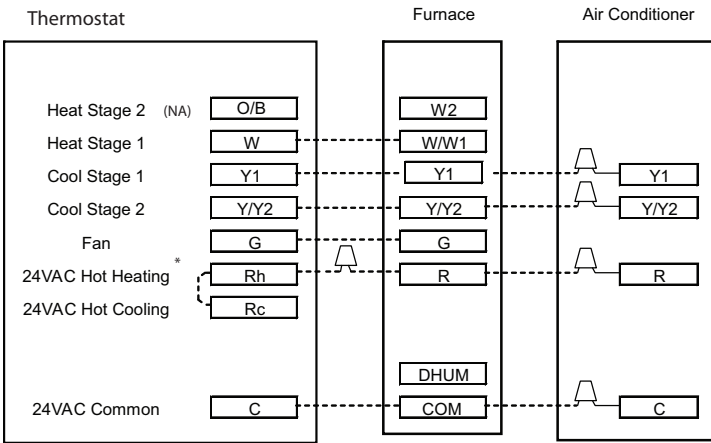

* Remove jumper when using split power (Indoor and Outdoor units utilize separate transformers).

A12240

Fig. 4 - Variable Speed, Step Modulating, Multi-Stage and Single-Stage Furnace with 2-Stage Air Conditioner
Equipment configuration: AC

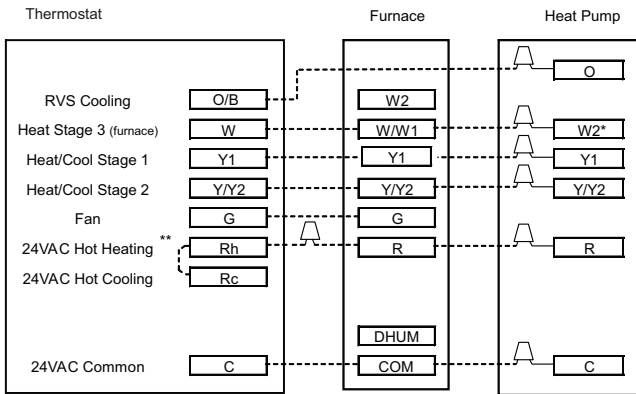

* Some heat pumps may designate W1.

**Remove jumper when using split power (Indoor and Outdoor Units utilize separate transformers).

A12241

Fig. 5 - Variable Speed, Multi-Stage, Stage Modulating and Single-Stage Furnace with 2-Stage Heat Pump

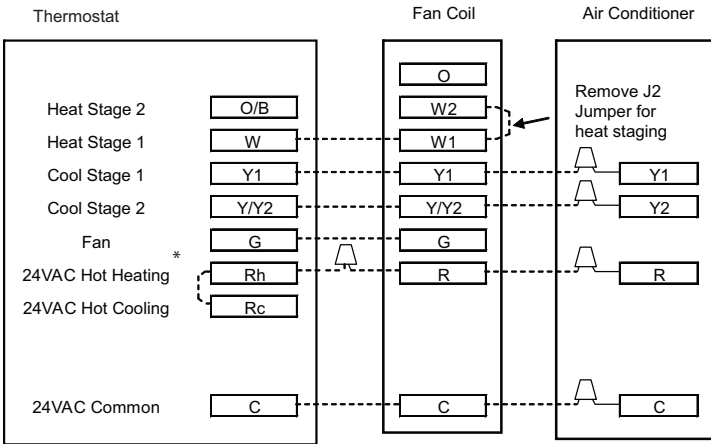

*Remove jumper when using split power (Indoor and Outdoor units utilize separate transformers).

A12242

Fig. 6 - FV/FK Fan Coil w/2- Stage Air Conditioner

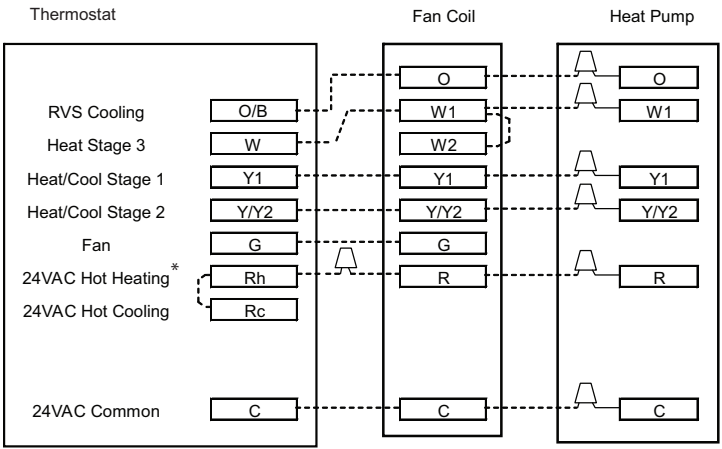

*Remove jumper when using split power (Indoor and Outdoor units utilize separate transformers).

A12243

Fig. 7 - FV/FK Fan Coil w/2-Stage Heat Pump

THERMOSTAT OPERATION FEATURES

Clock

Without batteries the clock will continue to operate for 8 hours after power is removed. With batteries, the clock operates until the end of the battery life.

Batteries

If installed without a common (C) wire, two alkaline AA batteries are required for operation. The thermostat is designed to operate up to one year on a set of batteries. A battery indicator on the display warns when battery replacement is needed. See Owner's Manual for details.

If installed with a Common (C) wire and batteries, the thermostat will use batteries only when 24VAC power is not present. The changeover between 24VAC power and battery power is automatic.

Display Lighting

The display has two levels of lighting, high level and low level. High level lighting comes on for 10 seconds when the door is opened and/or buttons are being pressed when installed with a Common (C) wire or with batteries.

Low level lighting is only available if the thermostat is installed with a Common (C) wire. It is not available with batteries. The low level can be selected (see Configuration Option 18) for continuous backlight.

Door Switch

When the door is opened, the display changes from its normal operation view. The large temperature display disappears so it will be available for other functions. If the door is left open for 3 minutes, the display reverts to normal operation.

Timers

There are several timers which influence the thermostat's operation: If any of the timers listed below is preventing the equipment from turning on, the display icons which show the equipment is operating will be flashing to indicate a turn-on delay is present.

Five-Minute Compressor Timeguard

This timer prevents the compressor from starting unless it has been off for 5 minutes.

Minimum On Timer

Once the equipment has been turned on, it must remain on for 3 minutes. A change in mode or setpoint will cancel this timer.

Cycle Timer

Based on the selection of 2, 4, or 6 cycles per hour, this timer is set to 30, 15, or 10 minutes. This much time must elapse from the start of one cycle before another cycle can start. It serves to impose the cycles per hour limits.

Auto Changeover Timer

To prevent unnecessary cycling between heating and cooling modes, this timer prevents a changeover to the opposite mode until a demand exists in the opposite mode for 20 minutes. It is defeated when setpoints are changed so that the opposite mode is immediately available if desired.

TROUBLESHOOTING

Your thermostat does not power on:

Check the following:

1. Turn off the power to your system. Check that all wires are properly inserted into the terminal blocks at the thermostat.
2. Tug lightly on the wires to ensure they are not loose.
3. Ensure you turned the power back on to the equipment either at the switch at the indoor equipment or the electrical panel (where you originally turned off the equipment).
4. If your device still doesn't power on check the AC voltage between Rc and C or Rh and C using a multi-meter to ensure it is 24V AC.
5. If your device still does not power on, please contact:
 - Technical support at 1.800.CARRIER or contact contact.carrier@carrier.utc.com
6. Find an Expert Carrier Contractor at www.carrier.com/dealers

Backlight will not come on:

1. If your thermostat is installed without a Common (C) wire and when the battery is low, the backlight will remain off with button presses.

Error Messages:

1. Two dashes (--) appear in the temperature display.
 - The thermostat must be replaced. The room temperature sensor failed and all heating and cooling outputs will be turned off.
2. E4 alternately flashes with the temperature on the display
 - The thermostat must be replaced. All heating and cooling outputs will be turned off.



Copyright 2017 Carrier Corporation 7310 W Morris St. Indianapolis, IN 46231

TC- PHP01BLK- 02SI **997- 015060- 1- R** **Replaces: TC- PHP01BLK- 01SI**

Edition Date: 02/17

Manufacturer reserves the right to change, at any time, specifications and designs without notice and without obligations.