



# Controls, Start-Up, Operation and Troubleshooting Instructions

IMPORTANT: This literature covers 50FCQ 04-07 and 50GCQ 04-06 models with SystemVu controls version 1.X (factory-installed option).

**SAFETY CONSIDERATIONS** ..... 3

**GENERAL** ..... 3

**Conventions Used in This Manual** ..... 3

**BASIC CONTROL USAGE** ..... 3

**SystemVu Control (factory-installed option)** ..... 3

**SystemVu Interface** ..... 4

**SystemVu Interface Operation** ..... 4

**Accessory Navigator Display** ..... 5

- NAVIGATOR DISPLAY OPERATION

**System Pilot and Touch Pilot Devices** ..... 6

**CCN Tables and Display** ..... 6

- FORCE HIERARCHY

**START-UP** ..... 6

**Unit Preparation** ..... 6

**Refrigerant Service Ports** ..... 6

**Crankcase Heater** ..... 6

**Compressor Rotation** ..... 6

**Power Supply** ..... 6

**Internal Wiring** ..... 6

**Evaporator Fan** ..... 7

**Condenser Fans and Motors** ..... 7

**Return-Air Filters** ..... 8

**Outdoor-Air Inlet Screens** ..... 8

**Accessory Installation** ..... 8

**CONTROLS QUICK SET-UP** ..... 9

**Control Set Point and Configuration Log** ..... 9

**Initial Start-Up** ..... 9

- QUICK SETUP
- NETWORK SETUP
- SYSTEM AUTO TEST

**Thermostat Control** ..... 10

**Space Temperature Sensor Control - Direct Wired (T-55 or T-56 or T-59)** ..... 10

**CCN Communication** ..... 10

**CCN Linkage Control** ..... 10

**System Pilot - Communication Space Sensor** ..... 10

**RNET Communication Space Sensors** ..... 10

**Field-Installed Accessories** ..... 10

- ECONOMIZER
- POWER EXHAUST
- ELECTRIC HEAT
- FIRE SHUTDOWN
- OUTDOOR ENTHALPY

- IAQ SENSOR
- OAQ SENSOR
- FILTER STATUS
- PHASE MONITOR
- TWO POSITION DAMPER

**Programming Operating Schedules** ..... 11

- OCCUPANCY SCHEDULE
- DAY OF WEEK
- OCCUPIED FROM
- OCCUPIED TO

**SERVICE TEST** ..... 11

**Independent Outputs** ..... 12

**Fan Test** ..... 12

**Cooling Test** ..... 12

**Heating Test** ..... 12

**Automatic Test** ..... 12

**THIRD PARTY CONTROL** ..... 12

**Cooling/Heating Control** ..... 12

**Remote Occupancy** ..... 12

**Remote Shutdown** ..... 12

**Alarm Output** ..... 12

**Economizer Damper Control** ..... 13

**CONTROLS OPERATION** ..... 13

**Display Configuration** ..... 13

**Unit Configuration** ..... 13

**Configurable Switches and Analog Sensors** ..... 14

**General Operation** ..... 14

**Demand Determination** ..... 15

- THERMOSTAT DEMAND
- SPACE SENSOR DEMAND

**Setpoint Determination** ..... 15

**Temperature Demand** ..... 16

- RAT DEMAND
- HUMIDITY DEMAND
- SPACE RELATIVE HUMIDITY

**Occupancy Determination** ..... 16

- LEVEL 1 PRIORITY
- LEVEL 2 PRIORITY
- LEVEL 3 PRIORITY
- INDOOR (SUPPLY) FAN MAXIMUM SPEED (MAXIMUM IDF SPEED)
- VENTILATION INDOOR FAN SPEED (VENT IDF SPEED)
- HEATING INDOOR FAN SPEED (HEATING IDF SPD)
- FREE COOLING INDOOR FAN SPEED (FREE COOL IDF SPD)
- LOW COOLING INDOOR FAN SPEED (LOWCOOL IDF SPD)
- HIGH COOLING INDOOR FAN SPEED (HIGH COOL IDF SPD)


<b>Cooling Operation</b> .....	<b>18</b>	• VIEWING AND CLEARING UNIT ALARMS	
• COOLING MODE CONTROL		• DIAGNOSTIC ALARM CODES AND POSSIBLE CAUSES	
• COOLING STAGING CONTROL			
• COMPRESSOR CONTROL		<b>Control Module Communication</b> .....	<b>32</b>
• OUTDOOR FAN CONTROL		• RED LED	
• NORMAL OPERATION		• GREEN LED	
• LOW AMBIENT OPERATION		• YELLOW LED	
<b>Indoor Fan Based Dehumidification</b> .....	<b>19</b>	<b>Communication Failures</b> .....	<b>32</b>
• MAX DEHUM		<b>Cooling Troubleshooting</b> .....	<b>33</b>
• MAX COMFORT		<b>Economizer Troubleshooting</b> .....	<b>34</b>
<b>Heating Operation</b> .....	<b>19</b>	• ECONOMIZER CALIBRATION	
• HEATING MODE CONTROL		<b>Heating Troubleshooting</b> .....	<b>35</b>
• SUPPLY-AIR TEMPERATURE SENSOR (SAT) HEAT MODE		• ELECTRIC HEAT	
• HEATING STAGING CONTROL		<b>Phase Protection</b> .....	<b>36</b>
• HEATER CONTROL		• PHASE REVERSAL PROTECTION	
• DEFROST CONTROL		• PHASE LOSS PROTECTION	
<b>Supply Air Tempering</b> .....	<b>21</b>	<b>Thermistor Troubleshooting</b> .....	<b>36</b>
<b>Two Position Damper Operation</b> .....	<b>21</b>	• AIR TEMPERATURES	
<b>Economizer Operation</b> .....	<b>21</b>	• THERMISTOR/TEMPERATURE SENSOR CHECK	
• MINIMUM VENTILATION		<b>Sensor Trim</b> .....	<b>36</b>
<b>Free Cooling</b> .....	<b>22</b>	<b>Transducer Troubleshooting</b> .....	<b>36</b>
• DRY BULB LOCKOUT		<b>MAJOR SYSTEM COMPONENTS</b> .....	<b>41</b>
• ENTHALPY LOCKOUT		<b>General</b> .....	<b>41</b>
• UNOCCUPIED FREE COOLING LOCKOUT		<b>Main Base Board (MBB)</b> .....	<b>50</b>
<b>Unoccupied Free Cooling</b> .....	<b>23</b>	<b>Protective Devices</b> .....	<b>52</b>
<b>Power Exhaust</b> .....	<b>23</b>	• COMPRESSOR PROTECTION	
<b>Indoor Air Quality (IAQ)</b> .....	<b>23</b>	• EVAPORATOR FAN MOTOR PROTECTION	
• IAQ (ANALOG INPUT)		• CONDENSER FAN MOTOR PROTECTION	
• OUTDOOR AIR QUALITY (ANALOG INPUT)		• SATURATED SUCTION PRESSURE (SSP)	
<b>Pre-occupancy Purge</b> .....	<b>25</b>	• CONDENSATE OVERFLOW SWITCH (COFS)	
<b>Temperature Compensated Start</b> .....	<b>25</b>	<b>Space Mounted Sensors</b> .....	<b>52</b>
<b>Smoke Control</b> .....	<b>25</b>	• SPACE TEMPERATURE SENSOR (T-55)	
• FIRE SHUTDOWN MODE		• SPACE TEMPERATURE SENSOR (T-56)	
• EVACUATION MODE		• ZS SPACE SENSOR	
• SMOKE PURGE MODE		<b>Carrier Comfort Network (CCN) Interface</b> .....	<b>54</b>
• PRESSURIZATION MODE		<b>APPENDIX A: SYSTEMVU™ CONTROLLER DISPLAY</b> .....	<b>56</b>
<b>Linkage</b> .....	<b>25</b>	<b>APPENDIX B: SYSTEMVU CONTROLLER TEXT POINT REFERENCE</b> .....	<b>81</b>
<b>Carrier Comfort Network (CCN) Operation</b> .....	<b>26</b>	<b>APPENDIX C: NAVIGATOR™ DISPLAY</b> .....	<b>82</b>
<b>BACnet Network Operation</b> .....	<b>26</b>	<b>APPENDIX D: SYSTEMVU CONTROLLER CCN TABLES</b> .....	<b>94</b>
<b>Alarm Handling</b> .....	<b>26</b>	<b>APPENDIX E: BACNET POINTS LIST</b> .....	<b>120</b>
• ALARM RELAY OUTPUT		<b>CONTROL SETPOINT AND CONFIGURATION LOG</b> .....	<b>132</b>
<b>TROUBLESHOOTING</b> .....	<b>26</b>	<b>UNIT START-UP CHECKLIST</b> .....	<b>CL-1</b>
<b>Complete Unit Stoppage</b> .....	<b>26</b>		
<b>Restart Procedure</b> .....	<b>26</b>		
<b>Faults and Alerts</b> .....	<b>27</b>		

## SAFETY CONSIDERATIONS

Installation and servicing of air-conditioning equipment can be hazardous due to system pressure and electrical components. Only trained and qualified service personnel should install, repair, or service air-conditioning equipment. Untrained personnel can perform the basic maintenance functions of replacing filters. Trained service personnel should perform all other operations.

When working on air-conditioning equipment, observe precautions in the literature, tags and labels attached to the unit, and other safety precautions that may apply. Follow all safety codes. Wear safety glasses and work gloves. Use quenching cloth for unbrazing operations. Have fire extinguishers available for all brazing operations.

Follow all safety codes. Wear safety glasses and work gloves. Have fire extinguisher available. Read these instructions thoroughly and follow all warnings or cautions attached to the unit. Consult local building codes and National Electrical Code (NEC) for special requirements.

Recognize safety information. This is the safety-alert symbol . When you see this symbol on the unit and in instructions or manuals, be alert to the potential for personal injury.

Understand the signal words DANGER, WARNING, and CAUTION. These words are used with the safety-alert symbol. DANGER identifies the most serious hazards which will result in severe personal injury or death. WARNING signifies a hazard which could result in personal injury or death. CAUTION is used to identify unsafe practices which may result in minor personal injury or product and property damage. NOTE is used to highlight suggestions which will result in enhanced installation, reliability, or operation.

### WARNING

#### ELECTRICAL SHOCK HAZARD

Failure to follow this warning could cause personal injury or death.

Before performing service or maintenance operations on unit, turn off main power switch to unit and install lockout tag. Ensure electrical service to rooftop unit agrees with voltage and amperage listed on the unit rating plate.

### CAUTION

#### UNIT DAMAGE HAZARD

Failure to follow this caution may cause equipment damage.

This unit uses a microprocessor-based electronic control system. Do not use jumpers or other tools to short out components or to bypass or otherwise depart from recommended procedures. Any short-to-ground of the control board or accompanying wiring may destroy the electronic modules or electrical components.

## GENERAL

This publication contains Start-Up, Controls, Operation, Service, and Troubleshooting information for the 50FCQ and 50GCQ rooftop heat pump units equipped with the factory-installed optional SystemVu controls (version 1.X or higher) and use Puron (R-410A) refrigerant. The specific base unit installation instructions, service manual and/or wiring label diagram may also be required in conjunction with this book as a guide to a specific unit on the roof. All units in Table 1 allow for stand-alone or network operation. The 50FCQ 04, 05, and 06 are single speed operation units. The 50FCQ 07 and all 50GCQ units are multi speed stage indoor fan SAV™ (staged air volume) units.

Table 1 — Rooftop Units

MODEL	SIZE	NOMINAL TONS
50FCQ	04	3
	05	4
	06	5
	07	6
50GCQ	04	3
	05	4
	06	5

## Conventions Used in This Manual

The following conventions for discussing configuration points for the local display (SystemVu controller or Navigator™ accessory) will be used in this manual.

Menu paths will be written with the main menu name first, then any menus or sub menus, each separated by an arrow symbol (→) and will also be shown in bold and italics. As an example, the General sub menu which is located in the Setting main menu under Unit Configuration menu would be written as ***SETTINGS → UNIT CONFIGURATIONS → GENERAL***.

This path name will show the user how to navigate through the local display to reach the desired menu. The user scrolls through the Menus using the up and down keys. The arrow symbol in the path name represents pressing ENTER to move into the next level of the menu structure.

Point names are referenced in parentheses and bold and italics as would be shown on the local display.

CCN point names are also referenced for users configuring the unit with CCN software instead of the local display. See Appendix A at the end of this manual.

## BASIC CONTROL USAGE

### SystemVu Control (factory-installed option)

The SystemVu control is a comprehensive unit-management system. The control system is easy to access, configure, diagnose and troubleshoot.

The SystemVu control system is fully communicating and cable-ready for connection to the Carrier Comfort Network® (CCN), Carrier i-Vu®, and Third Party BACnet<sup>1</sup> building management systems. The control provides high-speed communications for remote monitoring via the Internet. Multiple units can be linked together (and to other Direct Digital Control (DDC) equipped units) using a 3-wire communication bus.

The SystemVu control system is easy to access through the use of a integrated display module. A computer is not required for start-up. Access to control menus is simplified by the ability to quickly select from 7 main menu items. An expanded readout provides detailed explanations of control information. Only six buttons are required to maneuver through the entire controls menu. The display readout is designed to be visible even in bright sunlight.

1. BACnet is a registered trademark of ASHRAE (American Society of Heating, Refrigerating and Air -Conditioning Engineers).

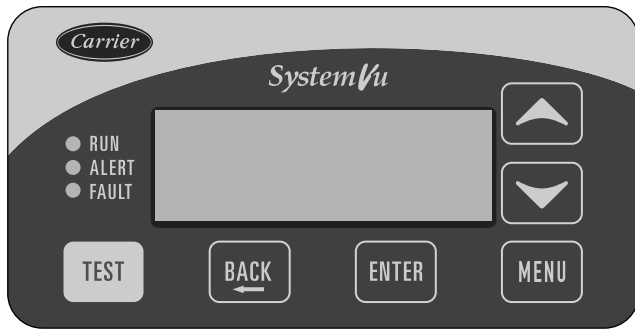


Fig. 1 — SystemVu Interface

### SystemVu Interface

This integrated device is the keypad interface used to access the control information, read sensor values, and test the unit. The interface is located in the main control box and is standard on all units. The interface is a 6-key, 4x30 character, LCD (liquid-crystal display) display module. The interface also contains Status LEDs. (See Fig. 1.) The interface is easy to operate using 6 buttons and the main menu structures shown in Fig. 2.

Through the SystemVu interface, the user can access all of the inputs and outputs to check on their values and status, configure operating parameters, and evaluate the current decision status for operating modes. The control also includes an alarm history which can be accessed from the display. The user can access a built-in test routine that can be used at start-up commissioning and troubleshooting.

### SystemVu Interface Operation

Units are shipped from the factory with the SystemVu interface FIOP, located in the main control box. (See Fig. 1.) In addition, the interface has up and down arrow keys, BACK, ENTER, MENU, and TEST keys. These keys are used to navigate through the different levels of the menu structure. All discussions and examples in this document will be based on the SystemVu display except in the Navigator display section. See the Accessory Navigator Display section for further details and Table 2 for the Navigator menu structure and usage.

The six keys are used to navigate through the display structure, which is organized in a tiered menu structure. If the buttons have not been used for a period, the display will default to a standby screen intended to provide a quick overall look at the system. To show the top-level display, press any key first to turn the display backlight on, and then press the MENU key. Then use the up and down arrow keys to scroll through the top-level menus. These are shown in Fig. 2 and listed in Appendix A.

When a specific menu or sub-menu is located, push the ENTER key to enter the menu. Depending on the menu, there may be additional tiers. Continue to use the up and down keys and the ENTER key until the desired display item is found. At any time, the user can move back a menu level by pressing the BACK key.

Once an item has been selected the display will flash showing the item, followed by the item value and then followed by the item units (if any). Pressing the TEST button at any time will jump the display to the test menu. Pressing the MENU button any time will jump the display to the main menu.

Items in the Configuration and Service Test menus are password protected. The display will prompt the enter password screen when required. Use the ENTER, BACK, and arrow keys to enter the four digits of the password. The default user password is 1111.

Pressing the BACK and ENTER keys simultaneously will show an expanded text description screen on the display indicating the full meaning of each display point. To put the screen in standby, hold down the BACK key for 5 seconds.

Some points can be forced from the SystemVu interface. To force a variable, follow the same process as editing a configuration parameter. A forced variable, regardless where the force has come from will be displayed with a lower case “f” following its value. For example, if *ECON CMD POSITION* is forced, the display shows “80%f”, where the “f” is to signify a force on the point. Remove the force by selecting the point that is forced with the key ENTER and then pressing the up and down arrow keys simultaneously. Pressing ENTER and BACK on a forced item will display the expanded description for that item including the force level that is currently applied. Depending on the type of unit (50FCQ or 50GCQ), factory-installed options and field-installed accessories, some of the items in the various menus may not apply.

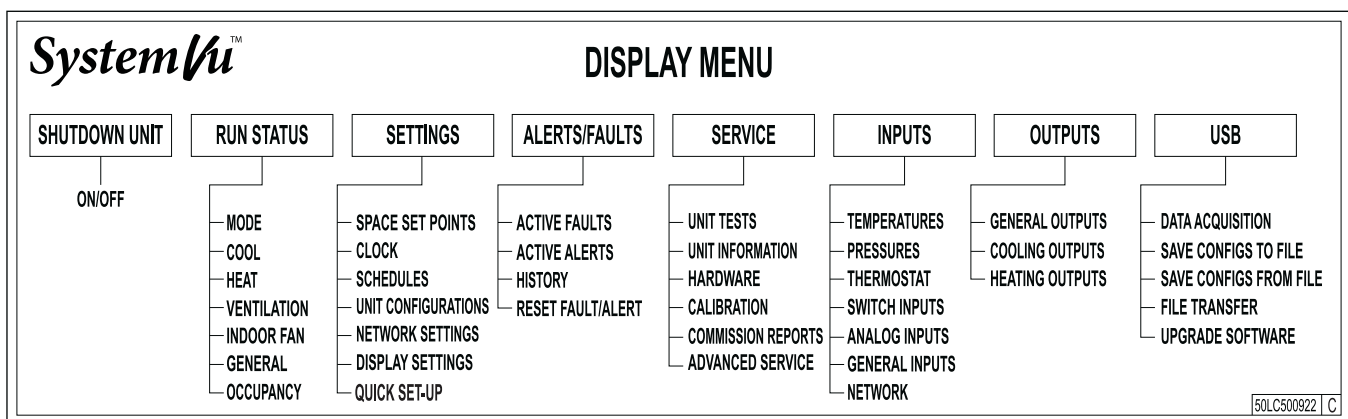
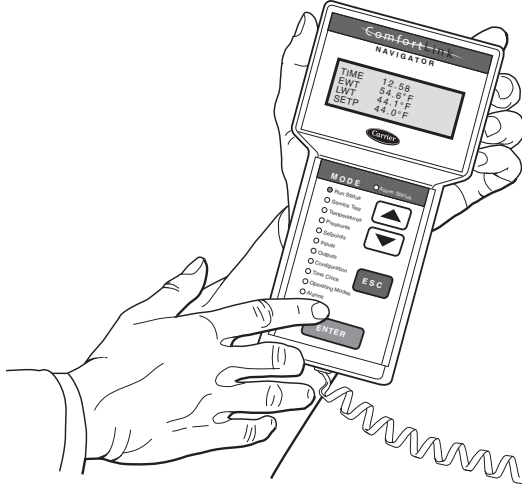


Fig. 2 — SystemVu - Main Menu Structures

## Accessory Navigator Display

The accessory hand-held Navigator display can be used with the 50FGQ/50GCQ units. (See Fig. 3.) The Navigator display is plugged into the LEN (local equipment network) port on either the SystemVu display or the Main Base Board (MBB).



**Fig. 3 — Accessory Navigator Display**

### NAVIGATOR DISPLAY OPERATION

The Navigator display has up and down arrow keys, an ESCAPE key and an ENTER key. These keys are used to navigate through the different levels of the display structure.

The four keys are used to navigate through the display structure, which is organized in a tiered mode structure. If the buttons have not been used for a period, the display will default to the AUTO VIEW display category as shown under the RUN STATUS category. To show the top-level display, press the ESCAPE key until a blank display is shown. Then use the up and down arrow keys to scroll through the top-level categories. These are listed in Appendix C and will be indicated on the Navigator display by the LED next to each mode listed on the face of the display.

When a specific mode or sub-mode is located, push the ENTER key to enter the mode. Depending on the mode, there

may be additional tiers. Continue to use the up and down keys and the ENTER keys until the desired display item is found. At any time, the user can move back a mode level by pressing the ESCAPE key. Once an item has been selected the display will flash showing the item, followed by the item value and then followed by the item units (if any).

Items in the Configuration and Service Test modes are password protected. The display will flash PASS and WORD when required. Use the ENTER and arrow keys to enter the four digits of the password. The default password is 1111.

Pressing the ESC and ENTER keys simultaneously will display an expanded text description across the display indicating the full meaning of each display point. Pressing the ESCAPE and ENTER keys when the display is blank (MODE LED level) will return the display to its default menu of rotating AUTO VIEW display items.

In addition, the password will need to be entered again before changes can be made.

Changing item values or testing outputs is accomplished in the same manner. Locate and display the desired item. If the display is in rotating auto-view, press the ENTER key to stop the display at the desired item. Press the ENTER key again so that the item value flashes. Use the arrow keys to change the value of state of an item and press the ENTER key to accept it. Press the ESCAPE key and the item, value or units display will resume. Repeat the process as required for other items.

There are some points that can be forced from the Navigator display. If the user needs to force a variable, follow the same process as when editing a configuration parameter. A forced variable, regardless where the force has come from will be displayed with a blinking “f” on a Navigator display following its value. For example, if economizer commanded position (*EC.CP*) is forced, the Navigator display shows “80F”, where the “f” is blinking to signify a force on the point. Remove the force by selecting the point that is forced with the key ENTER and then pressing the up and down arrow keys simultaneously.

Depending on the type of unit (50FCQ or 50GCQ), factory-installed options and field-installed accessories, some of the items in the various Mode categories may not apply.

See Table 2 and Appendix C for full Navigator display menu layout.

**Table 2 — Navigator Mode and Menu Display Structure**

RUN STATUS	SERVICE TEST	TEMPERATURES	PRESSURES	SETPOINTS	INPUTS	OUTPUTS	CONFIGURATION	TIMECLOCK	OPERATING MODES	ALARMS
Auto View of Run Status (VIEW)	Service Test Mode (TEST)				Thermostat Inputs (STAT)	General Outputs (GEN)	General Unit Config (GEN)	Time of Day (TIME)		Curr Active Alarm (CURR)
↓	↓				↓	↓	↓	↓		↓
Cooling Status (COOL)	Test Independent Outputs (INDP)				Switch Inputs (SW)	Cooling Outputs (COOL)	Indoor Fan Config (I.FAN)	Month, Date Day and Year (DATE)		History (HIST)
↓	↓				↓	↓	↓	↓		↓
Heating Status (HEAT)	Test Fans (FANS)				Analog Inputs (A S)	Heating Outputs (HEAT)	Economizer Config (ECON)	Daylight Savings Config (DST)		Reset All Current Alarms (R.CUR)
↓	↓				↓		↓	↓		↓
Ventilation Status (VENT)	Test Cooling (COOL)				General Inputs (GEN)		Building Net Config (NET)	Schedules Adjust (SCHD)		Alarm Reset History (R.HIS)
↓	↓						↓	↓		
Assigned I/O Channels (A.IO)	Test Heating (HEAT)						User Display Config (DISP)	Holiday Adjustment (HLDY)		
↓										
Versions (VERS)										

## System Pilot and Touch Pilot Devices

The System Pilot™ device (33PILOT-01) and Touch Pilot™ device (33CNTPILOT) can be used as CCN communication user-interfaces. These devices can be put on the CCN bus and addressed to communicate with any other device on the network. Unlike the SystemVu display and Navigator display, these pilots read the unit's CCN tables and its CCN points can be monitored, forced, or configured. The Pilot devices can be used to install and commission a 3V zoning system, linkage compatible air source, universal controller, and all other devices operating on the Carrier communicating network.

Additionally, the System Pilot device can serve as a wall-mounted temperature sensor for space temperature measurement. Occupants can use the System Pilot device to change set points. See Fig. 4 for System Pilot device details.

### CCN Tables and Display

In addition to the unit-mounted SystemVu display, the user can also access the same information through the CCN tables by using the service tool or other CCN programs/devices. The variable names used for the CCN tables and the SystemVu display menus may be different and more items may be displayed in the CCN tables. Details on the CCN tables are included in Appendix D.

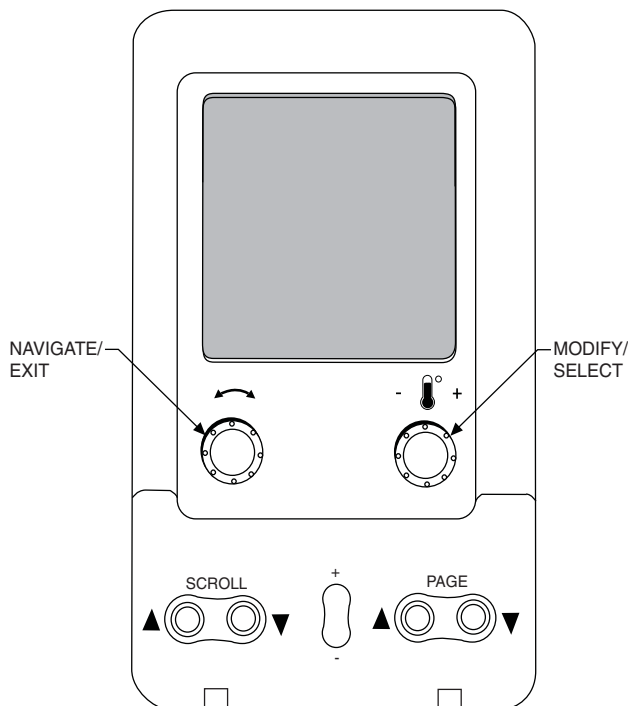


Fig. 4 — System Pilot User Interface

### FORCE HIERARCHY

There is a hierarchy in SystemVu controls with regards to forcing a point. Programs and devices write a force at different priority levels. A higher level (smaller number, 1 being the highest) will override a lower level force. The SystemVu controller uses a Control Force at level 7. The Navigator device writes a Service Force which is level 3. System Pilot and Touch Pilot devices write Supervisor Forces at level 4. Network programs can be set to write different level priority forces.

NOTE: In the case of a control power reset, any force in effect at the time of power reset will be cleared.

IMPORTANT: All further discussions and examples in this document will be based on the SystemVu controller.

## START-UP

IMPORTANT: Do not attempt to start unit, even momentarily, until all items on the Start-Up Checklist (see page CL-1) and the following steps have been read/completed.

### Unit Preparation

Check that unit has been installed in accordance with installation instructions and all applicable codes.

### Refrigerant Service Ports

The refrigerant system has a total of 3 Schrader-type service gauge ports per circuit. One port is located on the suction line, one on the compressor discharge line, and one on the liquid line. Be sure that caps on the ports are tight.

### Crankcase Heater

The compressor is equipped with a crankcase heater. There is a control function used to turn the crankcase heaters on and off when the compressor is not running. This is a configurable value for which the factory default value is set to 65°F. If the ambient is above the selected value the control will prevent the crankcase heater from turning on.

IMPORTANT: Unit power must be on for 24 hours prior to start-up to allow the crankcase heater to run. Otherwise, damage to the compressor may result.

### Compressor Rotation

#### CAUTION

#### UNIT DAMAGE HAZARD

Failure to follow this caution may result in unit damage. Improper wiring will cause compressor stoppage and alarm. Correct wiring by switching leads as indicated below.

On 3-phase units, it is important to be certain the compressors are rotating in the proper direction. To determine whether or not compressors are rotating in the proper direction, use a phase-rotation meter on the unit input power to check for L1-L2-L3 or clockwise rotation or use the Service Test mode to energize a compressor. If the compressor is rotating in the wrong direction, the controls will stop the compressor and display alarm for "Circuit A Reverse Rotation".

NOTE: Indoor or outdoor fan rotation direction may not indicate proper input power phase sequence, as some 3-phase units use single-phase fan motors.

To correct the wrong compressor rotation direction, perform the following procedure:

1. Turn off power to the unit and lock out the power.
2. Switch any two of the incoming unit power leads.
3. Turn on power to the unit.
4. Verify corrected compressor rotation.

### Power Supply

All 208/230-v units are factory wired for 230-v power supply. If the 208/230-v unit is to be connected to a 208-v power supply, the transformers must be rewired by moving the wire from the 230-volt connection and moving to the 200-volt terminal on the primary side of the transformer. Refer to unit label diagram for additional information.

### Internal Wiring

Check all electrical connections in unit control boxes; tighten as required.

## Evaporator Fan

The evaporator fan does not need to be checked for rotation as it only operates in one direction. Refer to the unit product data for full Fan Performance tables and physical data. The specific unit's fan performance table is printed and adhered to the control box high voltage cover. See Fig. 5 for an example fan performance table.

Use the job specifications and unit fan performance table to determine the operating mode specific fan speeds. The following instructions are included in the unit installation instructions. When adjusting the Heating Fan Speed and High Cooling Fan Speed, ensure that the CFM is not lower than the minimum CFM allowed in the product data.

1. Check the job specifications for the CFM (cubic feet per minute) and ESP (external static pressure) required.
2. Using the chart on the Fan Speed Set Up labels (see Fig. 5), calculate the RPM from the CFM and ESP for the base unit plus any field accessories (as listed on the label).

NOTE: The Fan Speed Set Up labels are located on the High Voltage cover in the Control Box.

3. Press any key on the SystemVu interface to activate the display backlight and then press the MENU key.
4. Using the UP and DOWN arrow keys highlight SETTINGS and then press ENTER.
5. Use the DOWN arrow key highlight the UNIT CONFIGURATIONS menu then press ENTER.
6. Highlight UNIT CONFIGURATIONS then press ENTER.
7. Highlight INDOOR FAN and then press ENTER.

8. Refer to the job specifications to set the following, determining the values per the RPM Calculator label (Fig. 5). Use the UP and DOWN arrow keys and the BACK key to set the values. Press ENTER after setting each value to continue to the next selection.

- IDF VENT SPD
- IDF HEAT SPD
- IDF LOW COOL SPD
- IDF HIGH COOL SPD
- IDF FREE COOL SPD

Service test mode can also be used to temporarily operate the Evaporator Fan with a percentage (0-100%) command. The fan test menu will show the converted RPM from the percentage being commanded. Refer to the Service test section for more details.

Adjust the IDF Maximum Fan Speed (**IDF MAX SPEED**) to restrict higher fan speeds as needed for sensitive applications.

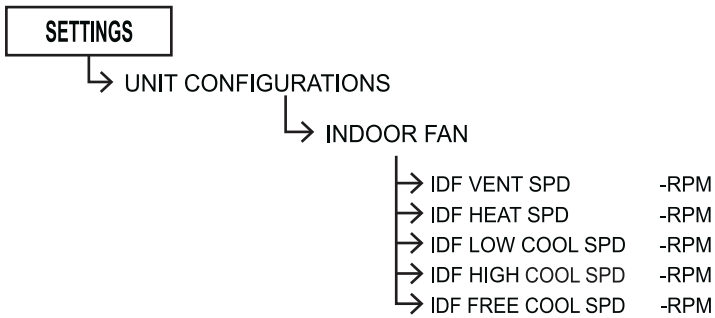
**IMPORTANT:** The IDF Maximum Fan Speed (**IDF MAX SPEED**) RPM must not produce a supply CFM that is lower than the minimum CFM allowed in the product data for heating and cooling. The IDF Maximum Fan Speed (**IDF MAX SPEED**) must also be greater than or equal to the highest operating mode speed setting.

## Condenser Fans and Motors

Condenser fans and motors are factory set.

**FAN SPEED SETUP (RPM)**

MAIN MENU:



↓ DETERMINE RPM FROM BELOW ↓

48TC003136 REV. A

RPM Calculator		ESP in. wg																		
		0.2	0.4	0.6	0.8	1.0	1.2	1.4	1.6	1.8	2.0									
<b>UNIT MODEL NUMBER</b>	<b>CFM</b>																			
	1500	1301	1477	1639	1788	1925	2054	2174	2289											
	1625	1381	1544	1699	1843	1976	2101	2220	2332											
	1750	1463	1615	1763	1902	2031	2152	2268	2378											
	1875	1548	1688	1828	1962	2087	2206	2318												
	2000	1633	1764	1897	2025	2146	2262	2372												
	2125	1720	1842	1967	2090	2208	2320													
	2250	1808	1921	2040	2157	2271	2380													
	2375	1897	2003	2115	2227	2336														
	2500	1987	2068	2191	2298															
<b>Field Accessories:</b>																				
	<b>Economizer</b>	66	66	66	66	66	66	66	66											
	<b>1 Stage E Heat</b>	80	80	80	80	80	80	80	80											
	<b>2 Stage E Heat</b>	107	107	107	107	107	107	107	107											

**Fig. 5 — Example of Fan Speed Set Up Labels**

**Return-Air Filters**

Check that correct filters are installed in filter tracks (see Physical Data table in unit Product Data). Do not operate unit without return-air filters. Determine the filter change run time (**DIRTY FILTER TIME**) to be set in the quick setup configurations menu. See Fig. 6 for filter access panel location.

**Outdoor-Air Inlet Screens**

Outdoor-air inlet screens must be in place before operating unit.

**Accessory Installation**

Check to make sure that all accessories including space thermostats and sensors have been installed and wired as required by the instructions and unit wiring diagrams.



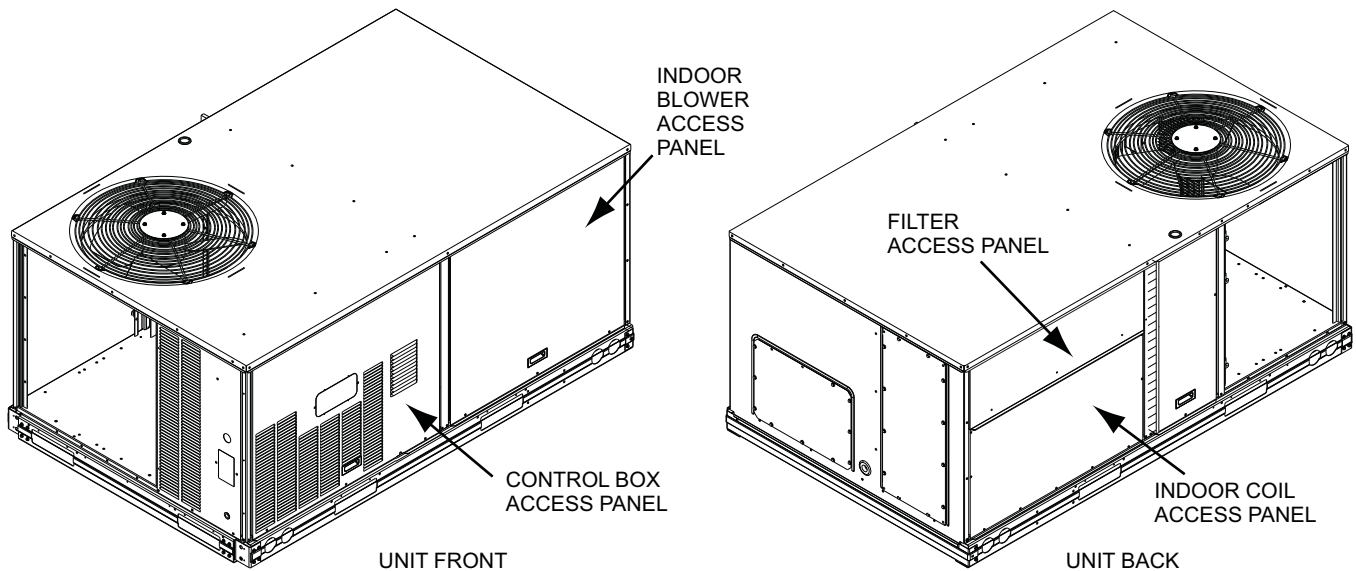


Fig. 6 — Panel and Filter Locations

## CONTROLS QUICK SET-UP

The following information will provide a quick guide to setting up and configuring the 50FCQ and 50GCQ series units with SystemVu controls. Unit controls are pre-configured at the factory for factory-installed options. Field-installed accessories will require configuration at start-up. Initial System Startup is recommended for initial start-up. Additionally, specific job requirements may require changes to default configuration values. See Appendix A and other sections of these instructions for more details. Refer to the Major System Components or accessory installation instructions for specific wiring detail.

### Control Set Point and Configuration Log

During start up, accessory installation, and equipment service set points and/or configuration changes might have to be made. When setting set points or configuration settings, documentation is recommend. The Control Set Point and Configuration Log starting on page 132 should be filled out and left with the unit at all times, a copy should also be provided to the equipment owner. A USB jump drive can be used to back up the unit's configurations. Refer to the USB Operation section for details.

### Initial Start-Up

Initial Startup refers to the first time this particular unit has a startup performed. The SystemVu controller will continually display the Initial Startup prompt until it is completed. To complete the initial startup you must complete the Quick Setup, Network Setup, and the System Auto Test.

#### QUICK SETUP

This a list of common adjusted configurations set during start-up. These are common accessories, and control means. Set the list in Table 3. After setting these per the specific unit set the **QUICK SET CHKLIST** point to done.

#### NETWORK SETUP

This is a shortcut to the Network Settings submenu. In this submenu are the specific network settings required to get the network piece up and running. After setting these per the specific unit set the **NETWORK CHKLIST** point to done.

#### SYSTEM AUTO TEST

Turning this to Start will run enable test mode and execute the System Auto Test. After the auto test has completed, set this to done.

Table 3 — Quick Setup Menu Items

SYSTEMVU DISPLAY	EXPANDED NAME	RANGE	DEFAULT
QUICK SETUP CONFIG	QUICK SETUP CONFIG MENU		
TIME	Clock Hour and Minute	HH:MM	
DATE	Current Date	MM/DD/YYYY	
STARTUP DELAY	Unit Startup Delay	10 to 600	30
UNIT CONTROL TYPE	Unit Control Type	0=TSTAT, 1=SPACE SEN, 2=RAT SEN	0
THERMOSTAT TYPE	Thermostat Hardware Type	0=CONV 2C2H, 1=DIGI 2C2H, 2=CONV 3C2H, 3=DIGI 3C2H	2
DIRTY FILTER TIME	Change Filter Timer	0 to 9999	0
TIME BTWN DEFROST	Min Time BTWN Defrosts	30 to 120	60
HEATING STAG QTY	Number of Heating Stages	1 to 3	1*
VENT METHOD	Ventilation Method	0=NONE 1=ECON 2=2POS DMPR 3=ERV 4=ECON ERV	0*
FREECOOL MAX OAT	Free Cooling Max OAT	0 to 90	65
FIRE SW CHANNEL	Fire Switch Channel	0 =None, 1=MBB DI12, 2=MBB DI13, 3=MBB DI14, 4=MBB DI02, 5=MBB DI03, 6=MBB Y3	0*=None,
IDF LOW COOL SPD	IDF Low Cool Speed-RPM	0 to 3000	1500*
IDF HIGH COOL SPD	IDF High Coll Speed-RPM	0 to 3000	2000*
IDF VENT SPD	IDF Vent Speed-RPM	0 to 3000	1300*
IDF HEAT SPD	IDF Heat Speed-RPM	0 to 3000	2100*
QUICK SET CHKLIST	QUICK SETUP CHECKLIST	0=Undone, 1=View, 2=Done	0

\* These defaults change based on the Unit model number.

## Thermostat Control

Wire accessory thermostat to the corresponding R, Y1, Y2, W1, W2, and G terminals on the Main Base board.

The Unit Control Type configuration, (**UNIT CONTROL TYPE**) default value is for thermostat (0) so there is no need to configure this item.

The Thermostat Hardware Type, (**THERMOSTAT TYPE**) selects the unit response to the thermostat inputs above.

NOTE: May not be compatible with heat anticipator thermostats.

## Space Temperature Sensor Control - Direct Wired (T-55 or T-56 or T-59)

Wire accessory space temperature sensor(s) to the T-55 terminals on the field connection terminal board located at the unit control box. Refer to Space Mounted Sensors section (page 52) for additional information.

The Unit Control Type configuration, (**UNIT CONTROL TYPE**) must be set to Space Sensor (1).

## CCN Communication

First configure the building protocol **SETTINGS** → **NETWORK SETTINGS** → **BAS PROTOCOL** to CCN (default is 0 = NONE). Configure the following under the CCN menu (**SETTINGS** → **NETWORK SETTINGS** → **CCN**).

**CCN ELEMENT #** - Default is 1

**BUS NUMBER** - Default is 0

**CCN BAUDRATE** - Default is 2 = 38400

## CCN Linkage Control

The CCN communication must be properly configured for the units and all other devices. Linkage configuration is automatically done by the supervisory CCN Linkage device.

The unit control type configuration, (**UNIT CONTROL TYPE**) must be set to space sensor (1).

The factory location of the SAT sensor will read accurately for heating and cooling for proper operation with linkage applications, therefore the SAT heating mode sensing configuration (**SAT DURING HEAT?**) is enabled from the factory. If a more accurate SAT reading is needed, the sensor can be re-located into the duct and no configuration adjustment needed.

## System Pilot - Communication Space Sensor

Install the System Pilot device and connect the CCN communication bus from it to the unit's CCN connection on TB4 - BAS connector of the Main Base Board (MBB). Configure the unit's CCN communication element number, bus number, and baud rate. Refer to the System Pilot device's installation instructions for configuring it to be used as a space temperature and attaching it to a unit.

## RNET Communication Space Sensors

The SystemVu controller will support the use of ZS sensors, Equipment Touch™, and System Touch™ on the RNET communication bus connections J20 and J24. Set the **Unit Control Type** configuration to space sensor to enable unit control with these sensors. Also set the BMS Port Configuration to BACnet in order to enable RNET Communications.

## Field-Installed Accessories

Below are quick configuration settings for field-installed accessories. When factory-installed as options the points will already be configured. See the Space Mounted Sensors section (page 52), third party control, control connection tables, and CCN or Display parameter tables for any accessories not mentioned below and refer to installation manual of the accessory.

## ECONOMIZER

When an economizer is field-installed, the unit must be configured for it by setting **SETTINGS** → **UNIT CONFIGURATIONS** → **ECONOMIZER** → **VENT METHOD** to ECON. The default settings for the other economizer configurations should be satisfactory. If they need to be changed, additional information about these configuration settings can be found in the Economizer section.

## POWER EXHAUST

When power exhaust is field-installed, the unit must be configured for it by setting **SETTINGS** → **UNIT CONFIGURATIONS** → **ECONOMIZER** → **POWER EXHAUST CONFIGS** → **PE1 RELAY CHANNEL** to the channel the accessory was wired into. The default settings for the other power exhaust configurations should be satisfactory. If they need to be changed, additional information about these configurations can be found in the Power Exhaust section.

## ELECTRIC HEAT

When electric heat is field-installed, the number of electric heat stages must be configured by setting **SETTINGS** → **UNIT CONFIGURATIONS** → **HEATING** → **HEATING STAGE QTY** per the installed heater.

## FIRE SHUTDOWN

When Fire Shutdown or Smoke Detector sensors are field-installed, the unit must be configured for it by setting **SETTINGS** → **UNIT CONFIGURATIONS** → **SWITCH INPUTS CONFIGS** → **FIRE SW CHANNEL** to the channel number the switch was wired into.

## OUTDOOR ENTHALPY

When an Outdoor Enthalpy sensor is field-installed, the unit must be configured for it by setting **SETTINGS** → **UNIT CONFIGURATIONS** → **ANALOG INPUTS CONFIGS** → **OARH SENSOR CHAN** to the channel number the sensor was wired into.

## IAQ SENSOR

When a CO<sub>2</sub> sensor is field-installed, the unit must be configured for it by setting **SETTINGS** → **UNIT CONFIGURATIONS** → **ANALOG INPUT CONFIGS** → **IAQ SENSOR CHAN** selects the unit response to this input. Default conversion to 0 to 2000 ppm.

## OAQ SENSOR

When an Outdoor Air Quality sensor is field-installed, the unit must be configured for it by setting **SETTINGS** → **UNIT CONFIGURATIONS** → **ANALOG INPUT CONFIGS** → **OAQ SENSOR CHAN**. Default conversion to 0 to 2000 ppm.

## FILTER STATUS

When a Filter Status Switch is field-installed, the unit must be configured by setting the input channel it is wired to and normal state. **SETTINGS** → **UNIT CONFIGURATIONS** → **SWITCH INPUT CONFIGS** → **FILTER SW CHANNEL** and **FILTER SW TYPE**.

## PHASE MONITOR

When a phase monitor is field-installed, the unit must be configured by setting the input channel it is wired to and normal state **SETTING** → **UNIT CONFIGURATIONS** → **SWITCH INPUTS CONFIGS** → **PHASE MON CHANNEL** and **PHASE MON SW TYPE**.

## TWO POSITION DAMPER

When a Two Position damper is field-installed, the unit must be configured by setting the output channel it is wired to. **SETTINGS** → **UNIT CONFIGURATION** → **GENERAL** → **2POS/ERV CHANNEL**.

## Programming Operating Schedules

When the building automation system you have the SystemVu controller configured for (**BAS Protocol Select**) is None (0) or CCN (1) the SystemVu controller can follow a standard CCN occupancy table. The occupancy can be modified from any CCN tool or from the local display.

### OCCUPANCY SCHEDULE

For flexibility of scheduling, the occupancy programming is broken into eight separate periods. For each period the schedule contains the following fields: Day of Week, Occupied From, and Occupied To.

### DAY OF WEEK

The day of week configuration consists of eight fields corresponding to the seven days of the week and a holiday field in the following order: Monday, Tuesday, Wednesday, Thursday, Friday, Saturday, Sunday, and Holiday. If a 1 is configured in the corresponding place for a certain day of the week, the related “Occupied from” and “Occupied to” times for that period will take effect on that day of the week. If a 1 is placed in the holiday field, the related times will take effect on a day configured as a holiday. A zero means the schedule period will not apply to that day.

Day of week: Range 0 or 1

Default Values 0 for all of the periods.

### OCCUPIED FROM

This field is used to configure the hour and minute, in 24 hour clock, that the mode for the controller will switch to occupied.

Occupied From: Units Hours:Minutes

Range 00:00 to 24:00

(Minutes 00 to 59)

Default Value 00:00

### OCCUPIED TO

This field is used to configure the hour and minute, in 24 hour clock, that the mode for the controller switches from occupied to unoccupied.

Occupied To: Units Hours:Minutes

Range 00:00 to 24:00

(Minutes 00 to 59)

Default Value 00:00

When the building automation system configured to (**BAS PROTOCOL**) is BACnet, the occupancy and holiday information will be reset to defaults in preparation for receiving a BACnet occupancy object. While participating on a BACnet network these configurations cannot be changed at the local interface or with CCN tools. All scheduling is done from the BACnet interface designated to provide schedules.

## SERVICE TEST

The Service Test function can be used to verify proper operation of compressors, heating stages, indoor fan, outdoor fans, power exhaust fans, economizer, crankcase heaters, and the alarm relay. Use of Service Test is recommended at initial system start up and during troubleshooting. (See Table 4 for point details)

Service Test mode has the following changes from normal operation:

- Outdoor air temperature limits for cooling circuits, economizer, and heating are ignored.
- Normal compressor time guards and other staging delays are reduced to one minute or less.
- Circuit strike out time is reduced to 1 minute instead of 15 minutes.

- It may take up to 30 seconds to actually enter test mode after activating the command.

Press the TEST button on the SystemVu interface anytime to access the Test menu. Service Test mode can only be turned ON/OFF at the unit display. Once turned ON, other entries may be made with the display or through CCN. To turn Service Test mode on, change the value of **TEST MODE** to ON. To turn service test mode off, change the value of **TEST MODE** to OFF. Service Test mode will be automatically turned off based on keypad inactivity and the Service Mode Test Time out (**TEST MODE TIM OUT**).

NOTE: Service Test mode may be password protected. Refer to Basic Control Usage section for more information. Depending on the unit model, factory-installed options, and field-installed accessories, some of the Service Test functions may not apply.

**Table 4 — Test Mode Unit Test Directory**

DISPLY MENU/SUB MENU/NAME	EXPANDED NAME	VALUES
<b>UNIT TESTS</b>	Unit Tests Menu	
<b>TEST MODE</b>	Service Test Mode Enable	Off/On
<b>SERVICE TEST</b>	Service Test Menu	
<b>INDEPENDENTS</b>	INDEPENDENT TEST MENU	
ECON POS TEST	Economizer Position Test	0 to 100
BUMP COMP A1 TEST	Compressor Bump A1 Test	Off/On
REV VALVE SOL TST	Rev.Val. Sole. Cir.A Tst	Off/On
LLSV RELAY TEST	LiqLine Solenoid Test	Off/On
CCH RELAY 1 TEST	Crankcase Heater 1 test	Off/On
ALARM RELAY TEST	Alarm Output Relay Test	Off/On
PE1 RELAY TEST	Power Exhaust 1 Test	Off/On
PE2 RELAY TEST	Power Exhaust 2 Test	Off/On
2POS/ERV RLY TEST	2Position/ERV Relay Test	Off/On
DAMPER CALIBRATION	Damper Calibration Menu	
CALIBRATE DAMPER	Econ Damper Calibration	Off/On
<b>FAN TESTS</b>	Indoor and Outdoor Fan tests	
IDF SPEED TEST	Indoor Fan Speed Test	0 to 100
CONVERTED IDF RPM	Converted IDF Speed	XXXX
IDF MANUAL TRANS	IDF Manual Transition	Yes/No
ODF ON/OFF TEST	ODF On/Off Relay Test	Off/On
ODF RELAY TEST	ODF Speed Relay Test	Off/On
<b>COOL</b>	Cooling Status Menu	
COOL A1 TEST	Cooling W/Comp.A1 Test	Off/On
CIR A LOADER TEST	Cooling W/Comp.ALD Test	Off/On
IDF SPEED TEST	Indoor Fan Speed Test	0 to 100
ODF ON/OFF TEST	ODF On/Off Relay Test	Off/On
ODF RELAY TEST	ODF Speed Relay Test	Off/On
<b>HEAT</b>	Heating Status Menu	
MECH HEAT TEST	Mechanical Heating Test	Off/On
HEAT 1 TEST	Heating Stage 1 Test	Off/On
HEAT 2 TEST	Heating Stage 2 Test	Off/On
IDF SPEED TEST	Indoor Fan Speed Test	0 to 100
DEFROST TEST	Defrost Test	Off/On
<b>AUTOMATIC TEST</b>	Automatic Test Menu	
AUTO INDP TEST	AUTO INDEPENDENT TEST	Yes/No
AUTO COOL TEST	RUN AUTO COOLING TEST	Yes/No
AUTO HEAT TEST	RUN AUTO HEATING TEST	Yes/No
AUTO SYSTEM TEST	RUN AUTO SYSTEM TEST	Yes/No

## Independent Outputs

The **INDEPENDENTS** submenu is used to change output status for the economizer, power exhaust stages, crankcase heaters, the alarm relay, as well as perform a compressor bump test. These independent outputs can operate simultaneously with other Service Test modes. All outputs return to normal operation when Service Test is turned off. The compressor bump tests cannot be run while running cooling tests and will automatically turn off after one minute.

## Fan Test

The **FAN TESTS** submenu is used to setup or test speeds for the indoor fan. Use the **IDF SPEED TEST** point to control the indoor fan speed in terms of %, and use the **CONVERTED IDF RPM** point as feedback to help set the fan speed settings in terms of RPM. The indoor fan transition type point inform the test routine how to handle the fans while running the cooling or heating tests. Automatic will automatically transition the fans as the cooling or heating tests change. While the Manual transition will only run the fans as set by the test points.

## Cooling Test

The **COOL** submenu is used to test mechanical heat, defrost, and change output status for the individual compressors operation. The **HEAT** submenu service test outputs are reset to OFF for the cooling service test. Indoor fans and outdoor fans are controlled normally to maintain proper unit operation when set for automatic transition. The **IDF SPEED TEST** can be changed as needed for testing. These fans points show the requested speed not actual speed. All normal cooling faults and alerts are functional.

## Heating Test

The **HEAT** submenu is used to test mechanical heat, defrost, and test the individual heat stages. The **COOL** service test outputs are reset to OFF for the heating service test. Indoor fan and outdoor fan are controlled normally to maintain proper unit operation when set for automatic transition. The **IDF SPEED TEST** can be changed as needed for testing and shows the requested speed not actual speed. All normal heating faults and alerts are functional.

## Automatic Test

The **AUTOMATIC TEST** submenu is used to execute all the applicable tests to the system automatically. These include independent components, cooling, heating, and system. Table 5 shows the steps taken during the independent, cooling, and heating automatic tests. The Hold time represents the time at which that control waits before moving on to the next step.

The **AUTO SYSTEM TEST** will execute the independent auto test, then the cooling auto test, then the heating auto test. At the end of the system auto test a prompt will ask if you want to enter measured data and complete a service report.

## THIRD PARTY CONTROL

Third party controls may interface with the unit SystemVu controller through the connections described below. See other sections of these instructions for more information on the related unit control and configurations.

## Cooling/Heating Control

The thermostat inputs are provided on TB1 of the board. The Unit Control Type configuration, **UNIT CONTROL TYPE**, must be 0 (Tstat) to recognize the below inputs. Terminal R is the 24-VAC source for the following:

Y1 = first stage cooling

Y2 = second stage cooling

W1 = first stage heating

W2 = second stage heating

G = Indoor fan

**Table 5 — Independent, Cooling, and Heating Automatic Tests**

AUTO INDP TEST		
Step	Action	Hold (Sec)
1	Turn on Crankcase Heater Relay	0
2	Turn on Outdoor Fan	20
3	Switch to High Speed Outdoor Fan	20
4	Turn off Outdoor Fan	10
5	Set IDF speed to 100%	30
6	Turn on 2 position damper/ERV relay	30
7	Set Economizer Damper to 100%	60
8	Turn on power exhaust 1	10
9	Turn on power exhaust 2	10
10	Set Economizer Damper to 0%	60
11	Turn off power exhaust 2	10
12	Turn off power exhaust 1	10
13	Set IDF to the ventilation speed	30
14	Turn off 2 position damper/ERV relay	0
15	Turn on alarm relay	10
16	Turn off alarm relay	10
17	Set IDF to 0% speed	30
18	Turn on Reversing Valve	10
19	Turn off Reversing Valve	10
20	Turn on Liquid Line Solenoid Valve	10
21	Turn off Liquid Line Solenoid Valve	10
22	Turn off Crankcase Heater relay	0
AUTO COOL TEST		
Step	Action	Hold (Sec)
1	Set IDF auto transition	0
2	Turn on Cool A1 test	60
3	Turn on Compressor Loader test	30
4	Turn off ODF Speed Relay test	10
5	Turn off Compressor Loader test	60
6	Turn off Cool A1 test	30
AUTO HEAT TEST		
Step	Action	Hold (Sec)
1	Set IDF auto transition	0
2	Turn on Mechanical Heat	60
3	Switch to Defrost Mode	30
4	Switch to Mechanical Heat	30
5	Turn off Mechanical Heat	10
6	Turn on Heat 1 test	60
7	Turn on Heat 2 test	60
8	Turn off Heat 1 and Heat 2 tests	20

## Remote Occupancy

The remote occupancy input can be provided on one of the configurable inputs, most commonly TB3. The Remote Occupancy Switch configuration, **REMOTE OCC TYPE**, identifies the normally open or normally closed status of this input when unoccupied. The Remote Occupancy Channel configuration, **REMOTE OCC CHAN**, identifies the discrete input (DI) assigned for this function.

## Remote Shutdown

The remote shutdown input is provided for unit shutdown in response to switch input configured most commonly on TB3. The Remote Shutdown Switch configuration, **REM. SHUTDOWN TYPE**, identifies the normally open or normally closed status of this input when there is no shutdown command. The Remote Shutdown Channel configuration, **REM. SHUTDOWN CHAN**, identifies the discrete input (DI) assigned for this function.

## Alarm Output

The alarm output is provided on as a configurable relay, most commonly on TB2, to indicate when a current alarm is active.

The output will be 24-VAC if a current alarm exists. The Alarm Relay Channel configuration, **ALM RELY CHANNEL**, identifies the discrete output (DO) assigned for this function.

### **Economizer Damper Control**

For units with the economizer option or accessory, the damper position can be directly controlled through the IAQ sensor input. The IAQ Analog Input configuration, **IAQ LEVEL CONTROL** will have to set to 2 (**CTL MINP**). When **IA.CF** = 2, an external 4 to 20 mA source is used to move the damper 0% to 100% directly.

## **CONTROLS OPERATION**

### **Display Configuration**

The **SETTINGS**→**DISPLAY SETTINGS** submenu is used to configure the local display settings.

#### **METRIC DISPLAY**

This variable is used to change the display from English units to Metric units.

#### **LANGUAGE**

This variable is used to change the language of the SystemVu display. At this time, only English is available.

#### **CONTRAST ADJUST**

This is used to adjust the contrast of the SystemVu display.

#### **PASSWORD ENABLE?**

This variable enables or disables the use of a user password. The password is used to restrict use of the control to change configurations.

#### **VIEW USER PASSWORD**

This menu allows the user to view the user password. The password must be entered or disabled to view it.

#### **CHANGE USER PASSWORD**

This menu allows the user to change the user password. The password must be entered or disabled to change it.

### **Unit Configuration**

Many configurations that indicate what factory options and/or field accessories are installed and other common operation variables are included in **SETTINGS**→**UNIT CONFIGURATION** submenu. Some of these configurations will be set in the factory for the factory-installed options (FIOPs). Field installed accessories and custom control functions will require configuration changes. The **SETTINGS**→**UNIT CONFIGURATION**→**GENERAL** submenu contains the following control configurations. Refer to other specific sections for other configurations.

#### **STARTUP DELAY**

This configuration sets the control start-up delay after the power is interrupted. This can be used to stagger the start-up of multiple units.

#### **UNIT CONTROL TYPE**

This configuration defines if temperature control is based on thermostat inputs or space temperature sensor input. TSTAT value is when then unit determines cooling and heating demand by the state of G, Y1, Y2, W1, and W2 inputs from a space thermostat. This value is the factory default. SPACE SEN value is when the unit determines cooling and heating demand based on the space temperature and the appropriate set point. RAT SEN value is when the unit determines cooling and heating demand based on the return air temperature and the appropriate set point. SPACE SEN or RAT SEN are also used as Linkage configuration.

#### **THERMOSTAT TYPE**

This configuration applies only if Unit Control Type is Thermostat. The value determines how the inputs are interpreted. See the specific operation sections for more information. The following descriptions define what each value means.

0 = CONV 2C2H — Conventional Thermostat 2 stage cool and 2 stage heat.

1 = DIGI 2C2H — Digital Thermostat 2 stage cool and 2 stage heat.

2 = CONV 3C2H — Conventional Thermostat 3 stage cool and 2 stage heat. This is the default setting.

3 = DIGI 3C2H — Digital Thermostat 3 stage cool and 2 stage heat.

#### **ADAPTIVE TSTAT**

This configuration applies only if the Unit control type is Thermostat. When this is YES the control will use Adaptive Control for cooling and heating staging. When this is set to NO the control will use the Traditional Thermostat Control, however during integrated cooling Adaptive is always used.

#### **DIRTY FILTER TIME**

This configuration defines the life of the installed filter. A timer will count down from this number while the indoor fan is running. At the expiration of this timer, an alert will be activated to indicate a filter change is required.

#### **TEST MODE TIMEOUT**

This configuration defines the time at which a test mode test has not changed state will automatically disable test mode. This configuration will disable the timeout when set to 0 (Disabled).

#### **CCH MAX TEMP**

This configuration defines the temperature threshold for which the crankcase heater is no longer required to heat the compressor shell.

#### **STD BARO PRESSURE**

This configuration is used to specify the job location's standard barometer pressure reading. This will feed the BAROMETRIC PRESS when a network is not writing to it. This should be used to account for job site elevation if enthalpy calculations are being used.

#### **LINK STAGEUP TIME**

This configuration sets the cooling and heating stage up time during linkage operation.

#### **UNIT'S MAX SAT**

This setting is used to trigger the F412 — Run Away Heat Fault. Any time the unit supply air temperature is higher than this value the alarm will be generated and shutdown the unit. Default is 200°F (93°C).

#### **UNIT'S MIN SAT**

This setting is used to trigger the F202 — Freeze Protection Fault. Any time the unit supply air temperature falls below this value the alarm will be generated and shutdown the unit. Default is 32°F (0°C).

#### **AUTO SAT FAULTS?**

This setting allows the user to select whether the F202 — Freeze Protection Fault and F412 — Run Away Heat Fault can automatically reset with improved supply air temperatures, or if the unit remains in shutdown until the unit can be manually reset. Default is Yes to allow auto reset.

#### **SA FREEZE PROTECT**

This setting allows the F202 — Freeze Protection Fault to be disabled if the function is not desired. The fault will not activate, and unit will continue to run with extreme low supply air temperatures. Default is enabled to allow the function.

## Configurable Switches and Analog Sensors

The SystemVu controller has optional configurable inputs. These consist of six physical board switch inputs (discrete inputs) and three physical board analog inputs. There are more functions allowed for configuration than there are inputs. Each function will have a configuration for which input channel it is assigned to. Each switch function will also have a switch type configuration which defines that switches normal state. Table 6 shows the configurable switch input functions and what their normal and active states are. Table 7 shows the configurable analog input functions. The switch configurations can be found in the *SETTINGS* → *UNIT CONFIGURATIONS* → *SWITCH INPUT CONFIGS* sub-menu. The analog input configurations can be found in the *SETTINGS* → *UNIT CONFIGURATIONS* → *SWITCH INPUT CONFIGS* sub-menu. The configurable input assignment can be viewed in the *SERVICE* → *HARDWARE* → *ASSIGNED INPUTS/OUTPUTS* sub-menu.

Any of the Switch input functions can be configured and wired for use on any of the discrete input channels, see Table 8. Any of the analog sensor functions can be configured and wired for use in any of the analog input channels, see Table 9.

**Table 6 — Configurable Switch Input Function**

FUNCTION DESCRIPTION	NORMAL STATE	ACTIVE STATE
Humidistat	OFF	ON
Fire Shutdown	NORMAL	ALARM
Condensate Overflow	LOW	HIGH
Filter Status Switch	CLEAN	DIRTY
Remote Occupancy	UNOCC	OCCUPIED
Remote Shutdown	RUN	SHUTDOWN
General Status Switch	GOOD	ALARM
Enthalpy Switch Input	LOW	HIGH
Fan Status Switch Input	OFF	ON
Indoor Air Quality Override	NO	YES
Phase Monitor Switch Input	NORMAL	ALARM
Smoke Purge	OFF	ON
Smoke Pressurization	OFF	ON
Smoke Evacuation	OFF	ON

**Table 7 — Configurable Analog Input Functions**

FUNCTION DESCRIPTION	SENSOR TYPE	SENSOR VALUES
Space Relative Humidity Sensor	0-20mA	%RH
Outside Air Relative Humidity Sensor	0-20mA	%RH
Return Air Relative Humidity Sensor	0-20mA	%RH
Indoor Air CO <sub>2</sub> Sensor	0-20mA	PPM
Outside Air CO <sub>2</sub> Sensor	0-20mA	PPM
Outdoor CFM Sensor	0-20mA	CFM

**Table 8 — Configurable Discrete Input Channels**

CHANNEL NAME	BOARD CONNECTION	WIRE LOCATION
MBB DI12	MBB TB3-2	Included Connector on Board
MBB DI13	MBB TB3-4	Included Connector on Board
MBB DI14	MBB TB3-6	Included Connector on Board
MBB DI02	MBB J4-2	Special Connector on Board
MBB DI03	MBB J5-2	Special Connector on Board
MBB Y3	MBB TB1 – Y3	Screw Terminal

**Table 9 — Configurable Analog Input Channels**

CHANNEL NAME	BOARD CONNECTION	WIRE LOCATION
MBB AI06	MBB TB5-5	Included Connector on Board
MBB AI07	MBB J7-1	Pink Wire in return air section
MBB AI08	MBB J7-2	Gray Wire in return air section

## General Operation

50FCQ and 50GCQ units can provide cooling, dehumidification, heating, and ventilation. The operating mode (MODE) shows the highest level of operation of the unit at any given time. The operating sub-mode (SUB-MODE) shows the detail operation occurring while under a specific mode. Fig. 7 shows the MODE and SUB-MODE values.

Each unit will operate under one of three basic types of control, thermostat, space temperature sensor, or return air temperature sensor. There are many inputs, configurations, safety factors, and conditions that ultimately control the unit. Refer to the specific operation sections for detail on a specific unit operation. The control will set the demand based on these types of control and conditions, which then drives the operating mode.

When thermostat control is enabled (*UNIT CONTROL TYPE*), the unit will operate based on discrete input commands (G, Y1, Y2, W1, and W2) and there is a one minute time delay between modes and when re-entering a mode. The G command calls for ventilation, the Y1 and Y2 commands call for cooling, and the W1 and W2 commands call for heating. Thermostat Control Type (*THERMOSTAT TYPE*) affects how cooling operates based on Y1 and Y2 commands and if cooling/heating stage time guards are applied.

When space temperature sensor control is enabled (*UNIT CONTROL TYPE*), the unit will try to maintain the Space Temperature (*SPACE TEMPERATURE*) between the effective cool and heat setpoints (*EFF COOL SETPOINT* and *EFF HEAT SETPOINT*). However, to minimize unnecessary cool to heat and heat to cool changes, there is a 10 minute delay after the last stage turns off before the control will switch modes. Linkage operation overrides the mode changeover delay to 15 seconds. The cooling and heating Mode Select Time guards (*COOL MODE T.GUARD* and *HEAT MODE T.GUARD*) show the remaining time before allowing the respective mode to be entered.

MODE	OFF	VENT	COOL	HEAT	TEST
SUB-MODE	STARTING UP	MODE TIMEGUARD	ECON FREE COOLING	HEATING	MANUAL TEST
	IDLE - NO DEMAND	SUPPLY FAN ON	UNOCC. FREE COOL	DEFROST	AUTO TEST
	MODE TIMEGUARD		MECH. COOLING	SA TEMPERING	SHUTTING TEST OFF
	UNIT DISABLED		ECON/MECH COOLING	HEATING PREVENTED	
	URGENT SHUTDOWN		DEHUMIDIFICATION	SHUTTING HEAT OFF	
	SAFETY CONTROL		DEHUM/MECH COOL		
			DEHUM PREVENTED		
			COOLING PREVENTED		
		SHUTTING COOL OFF			

**Fig. 7 — Modes and Sub-Modes**

## Demand Determination

Based on the unit control type (*UNIT CONTROL TYPE*), alarm conditions, and user interaction, the control will determine an overall demand of the unit. Table 10 shows the possible system demands with their priority level and summary description.

### THERMOSTAT DEMAND

When the unit control type is configured for thermostat (*UNIT CONTROL TYPE = TSTAT*) the level 6 demand in Table 10 will be determined by thermostat inputs and the Thermostat Type configuration (*THERMOSTAT TYPE*) as shown in the tables below. Table 11 shows the cooling thermostat inputs and how they map to the system demand. Table 12 shows the heating thermostat inputs and how they map to the system demand.

### SPACE SENSOR DEMAND

When the unit control type is configured for space sensor (*UNIT CONTROL TYPE = SPACE SEN*) the level 5 demand in Table 8 will be determined by the space sensor inputs and setpoints as described below. The Effective Demand Temperature (*DEMAND CTRL TEMP*) represents the temperature which the control is using to control the space. This would come from the space sensor, building network, linkage, or the return air sensor.

## Setpoint Determination

Setpoints are used to control the unit. The Cool Setpoint in Effect (*EFF COOL SETPOINT*) and the Heat Setpoint in Effect

(*EFF HEAT SETPOINT*) are the points in which the unit is controlling to at a specific time. These points are read only points and change according to occupancy, the offset slider status, and network writes. The setpoint configurations are in the *SETTINGS* → *SPACE SET POINTS* submenu.

If the building is in occupied mode, the Occupied Cool Setpoint (*OCC COOL SETPOINT*) and the Occupied Heat Setpoint (*OCC HEAT SETPOINT*) are active. When the building is in unoccupied mode, the Unoccupied Cool Setpoint (*UNOCC COOL SETPOINT*) and the Unoccupied Heat Setpoint (*UNOCC HEAT SETPOINT*) are active. The heating and cooling set points are also separated by a Heat-Cool Set Point Gap (*HEAT-COOL SP GAP*) that is user configurable from 2 to 10 degrees F. This parameter will not allow the setpoints to be set too close together, it will change the last setpoint adjusted if it is set within the GAP.

When the space sensor has a setpoint slider adjustment, the cool and heat setpoints (occupied) can be offset by sliding the bar from one side to the other. The SPT Offset Range (+/-) (*SPT SLIDER RANGE*) sets the total positive or negative degrees that can be added to the setpoints. With the slider in the middle, no offset is applied. Moving the slider to the “COOL” side will subtract from each setpoint, and sliding it to the “WARM” side will add to the setpoints. The slider offset being applied at any given time is displayed as Space Temperature Offset (*SLIDER OFFSET VAL*)

**Table 10 — Demand List and Priority**

DEMAND	PRIORITY	DESCRIPTION
EMERGENCY	1	An emergency condition occurs which requires a unit shutdown
SMOKE CONTROL	2	A smoke input or building command is operating the unit.
SAFETY FAULT	3	A safety diagnostic requires the unit to run in safety mode.
SERVICE TEST	4	User request test mode
SHUTDOWN	5	A minor or user condition requires the unit to shutdown
NO DEMAND	6	There is no comfort demand from the building
FAN ONLY		Only circulation or ventilation is requested from the building
DEHUM		A dehumidification load is present in the building
LOW COOL		A low cooling load is present in the building
HIGH COOL		A high cooling load is present in the building
LOW COOL & DEHUM		A low cooling and dehumidification load is present in the building
HIGH COOL & DEHUM		A high cooling and dehumidification load is present in the building
UFC LOW COOL		A low cooling load is present in the building due to the unoccupied free cooling algorithm
UFC HIGH COOL		A high cooling load is present in the building due to the unoccupied free cooling algorithm
LOW HEAT		A low heating load is present in the building
HIGH HEAT		A high heating load is present in the building
SUPPLY AIR TEMPERING		Due to outside air, supply air is uncomfortably cool during ventilation

**Table 11 — Thermostat Cooling System Demands**

THERMOSTAT INPUTS		THERMOSTAT TYPE			
Y1	Y2	CONV 2C2H*	CONV 3C2H	DIGI 2C2H	DIGI 3C2H
0	0	No Cool	No Cool	No Cool	No Cool
0	1	Alert & Low Cool	Alert & Low Cool	High Cool	High Cool
1	0	Low Cool	Low Cool	Low Cool	Low Cool
1	1	High Cool	High Cool	High Cool	High Cool

\* Set the LOW COOL COMP as needed.

**Table 12 — Thermostat Heating System Demands**

THERMOSTAT INPUT		THERMOSTAT TYPE	
W1	W2	CONV 2C2H CONV 3C2H	DIGI 2C2H DIGI 3C2H
0	0	No Heat	No Heat
0	1	Alert & Low Heat	High Heat
1	0	Low Heat	Low Heat
1	1	High Heat	High Heat

## Temperature Demand

Space sensor staging control is an adaptive anticipation control that weighs the actual space demand against the trend of that demand. The control tries to anticipate the change in the space because of its current stage status. This anticipation is based on the demand trends. These trends will show the control how the space is reacting to the current running conditions and help it decide when to change the actual demand of the system. The following points are in the *RUN STATUS* → *MODE* submenu:

### COOLING DEMAND

This is the difference between the Cool Setpoint in Effect (*EFF COOL SETPOINT*) and the Effective Demand Temperature (*DEMAND CTRL TEMP*) representing the demand of the space for cooling.

### COOL DEMAND TREND

This is the rate of change of the cooling demand in degrees per minute, representing how the space is changing its demand for cooling.

### HEATING DEMAND

This is the difference between the Heat Setpoint in Effect (*EFF HEAT SETPOINT*) and the Effective Demand Temperature (*DEMAND CTRL TEMP*) representing the demand of the space for heating.

### HEAT DEMAND TREND

This is the rate of change of the heating demand in degrees per minute, representing how the space is changing its demand for heating.

In general the system demand will increase based on the demand compared to the demand switch states in Fig. 8. The demand cannot increase until Time guard 1 (*DEMAND TIMEGUARD1*) expires. The *LCON* and *LHON* thresholds will also cause the system demand to be reduced. When the demand hits the off switch stages the system demand will be set to NO DEMAND. These switch stages are in the *SETTINGS* → *SET POINTS* → *TEMP DEMAND CONFIG* submenu.

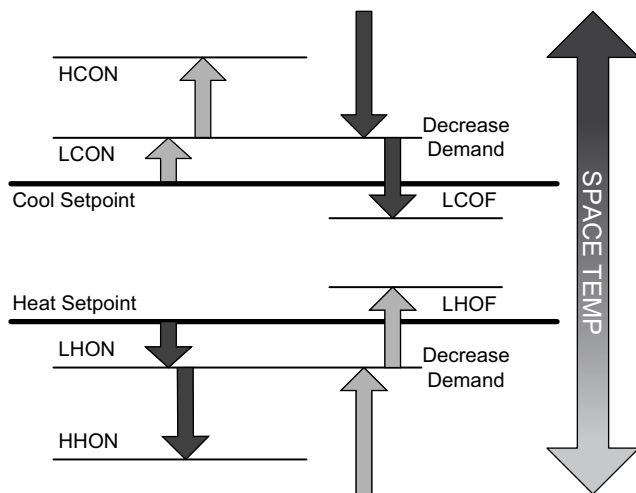


Fig. 8 — Space Sensor System Demand Switch States

The cooling and heating demand level up configurations (*COOL DMD LEVEL UP* and *HEAT DMD LEVEL UP*) will restrict a system demand increase if the demand trend is less than the level up configuration. These level up configurations will also increase the system demand if the demand trend is greater than it for greater than the Time guard 2 (*DEMAND TIMEGUARD2*).

The system demand will increase if it has remained at the same state for greater than Time Guard 3 (*DEMAND TIMEGUARD3*).

## RAT DEMAND

When the unit control type is configured for return air sensor (*UNIT CONTROL TYPE = RAT SEN*) the level 5 demand in Table 8 will be determined the same as space sensor but using the return air temperature (*RETURN AIR TEMP*) instead of the space temperature (*SPACE TEMPERATURE*).

## HUMIDITY DEMAND

When the unit is configured for Space Humidity Sensor (*SPRH SENS CHANNEL*) the level 5 demand in Table 8 will include a determination of dehumidification demand.

## SPACE RELATIVE HUMIDITY

On units with a relative humidity sensor, when the received value of space relative humidity (*SPRH LEVEL*) has exceed the humidity set point (*SPRH SET POINT*), dehumidification will be demanded. This demand will remain until the space relative humidity has fallen below the humidity set point by more than the humidity set point deadband (*SPRH DEADBAND*). This would come from the space humidity sensor, or building network.

## Occupancy Determination

The building's occupancy is affected by a number of different factors. Occupancy affects the unit set points and the operation of the economizer. The factors affecting occupancy are listed below from highest to lowest priority.

### LEVEL 1 PRIORITY

Level 1 classification is a force/write to occupancy and can occur two ways. Listed in order of priority: force on OCCUPIED, and a Linkage write. The CCN point OCCUPIED is forced via an external device such as a ComfortID controller or a service tool: when OCCUPIED is forced to YES, the unit is considered occupied, when OCCUPIED is forced to NO, the unit is considered unoccupied. If the unit is being controlled by Linkage, the occupancy is communicated and mapped to OCCUPIED as an input. Linkage does not force the point only write to it, therefore a force applied to OCCUPIED will override it.

If OCCUPIED is not being forced or written to, proceed to the level 2 priority.

### LEVEL 2 PRIORITY

Level 2 is considered occupant interaction, and consists of Timed Override and Remote Occupancy Switch. A timed override button press will override a remote occupancy switch if both are installed for operation.

While using the programmed schedule, occupancy can be temporarily switched from unoccupied to occupied by pressing the override button for approximately 3 seconds on the T-55, T-56, or T-59 space temperature sensor. The length of the override period when pressing the override button is determined by the Override Time Limit (*TIMED OVR LENGTH*). The hours remaining in override is displayed as Timed Override Hours (*TIMED OVR HOURS*). This point can also be changed from the local display or network to set or change the override period length.

Remote Occupancy Switch (*REMOTE OCC SWITCH*) can be forced or configured for operation based on an actual switch. The physical switch should be configured to either Normally Open or Normally Closed when the user would like to control the occupancy with an external switch. This switch is field-supplied (24v, single pole, single throw [SPST]). There are two possible configurations for the remote occupancy switch:

1. (*REMOTE OCC TYPE = 0*) Normally Open Switch
2. (*REMOTE OCC TYPE = 1*) Normally Closed Switch

If the switch is configured to No Switch (*REMOTE OCC CHAN = None*), the switch input value will be ignored and software will proceed to level 3 priority. For each type of



switch, the appropriate configuration and states are listed in the following table.

TYPE OF SWITCH	SWITCH CONFIGURATION	STATE OF SWITCH AND STATE OF OCCUPANCY
Occupied when Closed or Unoccupied when Open	Normal Open (0)	Open and Unoccupied
		Closed and Occupied
Occupied when Open or Unoccupied when Closed	Normal Closed (1)	Open and Occupied
		Closed and Unoccupied

### LEVEL 3 PRIORITY

The following occupancy options are determined by the state of Occupancy Schedule Number (**SCHEDULE NUMBER**) and the Global Schedule Broadcast (**BROADCAST SCHEDL?**).

1. (**SCHEDULE NUMBER = 0**) The unit is always considered occupied and the programmed schedule is ignored. This is the factory default.
2. (**SCHEDULE NUMBER = 1-64**) Follow the local programmed schedule. Schedules 1 to 64 are local within the controller. The unit can only store one local schedule and therefore changing this number only changes the title of the schedule table.
3. (**SCHEDULE NUMBER = 65-99**) Follow the global programmed schedule. If the unit is configured as a Global Schedule Broadcaster (**BROADCAST SCHEDL? = YES**), the unit will follow the unit's programmed schedule and broadcast the schedule so that other devices programmed to follow this schedule number can receive the schedule. If the unit is not programmed as a Global Schedule Broadcaster (**BROADCAST SCHEDL? = NO**), the unit will receive broadcasted schedules from a unit programmed to broadcast this schedule number.

### Indoor Fan Operation

These units use the Staged Air Volume (SAV) method of controlling the supply fan for a typical constant volume rooftop unit. This control method employs an Electronic Commutated Motor (ECM) to operate the supply fan at different speeds in order to achieve energy savings through reduced fan power. This method is specifically not concerned with controlling static pressure in the supply duct, but rather with setting different fan speeds for different operating conditions, such as ventilation mode or part-load mechanical cooling.

The SAV function is NOT a Variable Air Volume (VAV) function. The fan adapts its speed to one of seven based on mode and current state to satisfy a demand. The speeds consist of off (0%) and six configurable values. The configurable fan speeds are: Maximum Speed (**MAXIMUM IDF SPEED**), Ventilation (**VENT IDF SPEED**), Heating (**HEATING IDF SPD**), Free Cool (**FREE COOL IDF SPD**), Mechanical Low Cooling (**LOW COOL IDF SPD**), and Mechanical High Cooling (**HIGH COOL IDF SPD**). The ECM is powered direct from the distribution block and is always on with power applied unless the CB is tripped. When the thermostat or space sensor control conditions require the fan on, the ECM will then be ramped to desired speed. Fan speed is always calculated by evaluating the current applicable conditions. Each fan speed condition is evaluated independently, and the highest fan speed is used. For example, if a cooling call occurs during Ventilation mode, the unit mode will transition to cooling but the fan speed is set to the higher of the two (**VENT IDF SPEED** or **LOW COOL IDF SPD**). Refer to the speed configurations below for when the fan will run at them.

The Commanded Fan Speed (**OUTPUTS → GENERAL OUTPUTS → COMMANDED IDF RPM**) represents the controls commanded speed for the fan at any given time. This

commanded speed is determined by the unit's current HVAC mode and the unit control type. If configured for IAQ fan operation, the fan may be turned on to satisfy air quality demands. See the Indoor Air Quality section if using IAQ (indoor air quality) accessory sensors. The fan can run under thermostat or space sensor control and will remain on if compressors or heat relays are ever stuck on. If Shut Down on IDF Failure is enabled (**SHUTDOWN IDF FAIL = Yes**), the fan and unit will be shutdown without delay on fan alarm conditions. Fan off delays are honored when exiting specific HVAC modes. The Fan-off Delay delays are as follows: Cooling (**COOL FANOFF DELAY**), and Heating (**HEAT FANOFF DELAY**).

### INDOOR (SUPPLY) FAN MAXIMUM SPEED (MAXIMUM IDF SPEED)

Max speed is the highest fan speed allowed. This is set in terms of percentage instead of RPM and is defaulted to 100%. This max speed should be set lower if needed for building or duct protection. Most safety conditions for the unit will override the fan speed to this to help protect the unit.

IMPORTANT: **MAXIMUM IDF SPEED** is used in the minimum position curves and therefore important to set properly.

### VENTILATION INDOOR FAN SPEED (VENT IDF SPEED)

This configuration defines the fan speed used in Ventilation (fan-only) mode. Ventilation mode is when the supply fan is running, but there is no demand for heating or cooling. In thermostat mode, this is with just a G call. In space sensor control, this is when the unit is Occupied mode and the indoor fan is configured to always run while occupied (**OCCUPIED FAN?**). If the indoor fan is configured for intermittent fan (**OCCUPIED FAN? = No**), the Mode will be off instead of Ventilation and the fan will not run unless a heating or cooling mode is needed. During the unoccupied period, the fan will always operate intermittently. The economizer damper will adjust its position based on how far away this speed is from max speed for ventilation.

IMPORTANT: It is important that the ventilation rate is checked after setting this speed to verify that the unit can properly ventilate the space per requirements. Adjusting this configuration or the economizer minimum setting curve should be performed to meet job requirements.

### HEATING INDOOR FAN SPEED (HEATING IDF SPD)

This configuration defines the fan speed used when in heating mode and running heat. On units configured for Electric heat (**UNIT TYPE OF HEAT**) and configured for Preheat without the fan (**PREHEAT W/O IDF**), this heat speed will be delayed on based on the Preheat fan delay time (**PREHEAT FAN DELAY**). Once this preheat time has expired or not configured for preheat, the fan will run at this heat speed while heat is on.

### FREE COOLING INDOOR FAN SPEED (FREE COOL IDF SPD)

This configuration defines the initial fan speed used when in Free Cooling. Refer to the Economizer Controls Operation section for details on free cooling. The fan will stay at this configured speed whenever only the damper is being used for free cooling. If the damper is at 100% for 5 minutes the fan will ramp to the high cooling speed. It is locked there until the actual damper position falls below 75% at which time it will ramp back down to this configured speed.

## LOW COOLING INDOOR FAN SPEED (LOWCOOL IDF SPD)

This configuration defines the fan speed used when the first stage of mechanical cooling is being performed.

## HIGH COOLING INDOOR FAN SPEED (HIGH COOL IDF SPD)

This configuration defines the fan speed used when all (full load) stages of mechanical cooling is being performed. When performing integrated cooling with the economizer this speed will be used. When only free cooling with a high cool demand, this speed will be used.

## Cooling Operation

The unit's cooling operation consists of: demand and mode determination, staging request to satisfy the demand, and handling a request with the unit's resources. These resources can include compressors, an economizer, and fan speed based on options. This section covers mechanical cooling. For economizer free cooling, refer to the Economizer Operation section (starting on page 21).

## COOLING MODE CONTROL

The cooling HVAC mode (**OPERATING MODE**) has 9 different operating sub modes (**SUBMODE**): ECON FREE COOLING, UNOCC. FREE COOL, MECH. COOLING, ECON/MECH COOLING, DEHUMIDIFICATION, DEHUM/MECH COOLING, DEHUM PREVENTED, COOLING PREVENTED, and SHUTTING COOL OFF. These are all part of a general cooling mode and resemble the specific type of cooling that is being performed at any given time. All types of cooling are still performed under the general cooling function, and the expanded text is for user reference only.

For the unit to enter cooling mode, three things must be true: the indoor fan must be ok to use, the mode changeover time guard must be expired, and there must be a cooling or dehumidification demand (Y1, Y2, space cool demand, or humidity demand). The unit will remain in cooling for at least one minute or until any of the above conditions turn false. The cooling mode does not officially end until the compressor is off and the fan off delay has expired.

## COOLING STAGING CONTROL

Once the unit is in a cooling mode, determine what the demand is and how to satisfy it. If an economizer is installed and can be used for cooling (**OK TO USE FREE COOLING?** = *Yes*), the unit will use it first (see economizer section for its operation). If the economizer cannot be used or additional cooling is needed, a mechanical cooling check is performed. OK to use Compressors? (**OK TO USE COMPS?**) will be set to yes when the outdoor temperature (OUTDOOR AIR TEMP) is above the Circuit A Lockout temperature (**CIR.A LOCKOUT OAT**) and the Circuit A is not locked out for diagnostic reasons (**CIRCUIT A LOCKOUT**). Based on the unit control configuration, requested cooling stages (**REQ. COOL STAGES**) will be determined then passed to compressor control to actually add the cooling stages.

There are two ways of requesting stages when thermostat control is enabled, Traditional thermostat control or adaptive control. Traditional thermostat control is used if set for non-adaptive thermostat (**ADAPTIVE TSTAT** = *NO*) and the unit cannot use the economizer for free cooling. If set for adaptive thermostat (**ADAPTIVE TSTAT** = *YES*) or any time the economizer is available for free cooling, the unit will use adaptive control for staging.

When configured for Space sensor or RAT control (**UNIT CONTROL TYPE**) the unit will use adaptive control for staging. With either staging method there are two supply air temperature limits that apply, one restricts more cooling stages and the other will remove cooling stages. If at any time the Supply-Air Temperature

(**SUPPLY AIR TEMP**) falls below the Minimum Supply Air Temperature Upper Level (**UPPER MIN SAT**), the requested stages will not be allowed to increase. If at any time the SAT falls below the Minimum Supply Air Temperature Lower Level (**LOWER MIN SAT**), the requested stages will be reduced by one. If these SAT limits are configured so that they are too close together, the last stage might cycle rapidly, slowed only by its minimum on and off-time requirements.

## Adaptive Control

Stage timers and Supply air trend apply when determining the request for stages. The first request (**REQ. COOL STAGES** = *I*) comes immediately when starting the staging process. The Cool Stage Increase Time (**COOL STAGEUP TIME**) has to expire and the Supply-Air Trend (**SUPPLY AIR TREND**) has to be above the cooling supply air trend level (**COOL SAT-TREND LEV**) before another stage can be added. Requested stages will only be allowed to increase as the actual system demand allows (DEMAND). A "LOW COOL" demand will only allow one requested stage, and "HIGH COOL" all stages. The requested stages will be reduced if the cooling demand is lowered or dropped completely, or if the supply air falls below the lower level (**LOWER MIN SAT**).

## Traditional Thermostat Control

Stage timers and Supply air trend do not apply when determining the request for stages. Request staging will follow the thermostat inputs directly. "LOW COOL" will request one stage. "HIGH COOL" will request two stages.

## COMPRESSOR CONTROL

The compressor control works hand and hand with the staging control. As the staging control request stages, the compressor control determines what is available or running and tries to provide stages for what is requested. The availability of the compressors depends on time guards, circuit diagnostics, and outdoor temperature.

There are time guards to protect the compressor, Compressor Min On Time (**COMP MIN ON TIME**) and Compressor Min Off Time (**COMP MIN OFF TIME**) apply before the compressor can be turned back on or turned off. Timeguard A1 (**COMP A1 TIMEGUARD**) and Timeguard loader (**COMP LDR TIMEGUARD**) display the time the compressor and loader have before available for use.

Circuit diagnostic tests are performed during operation which may or may not allow the compressor to be used. The availability of the compressor is shown as Compressor A1 Available (**COMP A1 AVAILABLE**). The lockout status of the compressor is shown as Compressor A1 Lockout (**COMP A1 LOCKOUT**). The actual stages running at any given time is displayed as Actual Cooling Stages (**ACTIVE COOL STAGE**). Individual compressor output state is shown as (**COMPRESSOR A1**) and (**COMP A LOADER**).

Any time the outdoor ambient falls below the low cooling minimum outdoor temperature (**LOW COOL MIN OAT**), the low cooling lockout will be active (**LOW COOL LOCKOUT**) preventing compressor A1 from running by itself. This means the loader will be on with the compressor.

## OUTDOOR FAN CONTROL

The outdoor fan can be set for a single speed or 2 speed motor. The 3 to 6 ton 50FCQ units will have a single speed ODF. The 3 to 5 ton 50GCQ will have a 2 speed ODF. The ODF Relay Enabled (**ODF RELAY ENABLE**) point will tell the control when a 2 speed motor is installed. The 2 speed relay state output is shown as Outdoor Fan Speed Relay (**ODF SPEED RELAY**). The on and off relay for the ODF is shown as **ODF ON/OFF RELAY**. AT any time the overall state of the ODF can be seen as **ODF STATE** under the cooling run status menu. Units with a low ambient option will also be equipped with a head pressure control device.

## NORMAL OPERATION

On the single speed ODF system, the ODF will come on and off with the compressor shown as **ODF ON/OFF RELAY**. On the 2 speed ODF systems, the ODF will come on and off with the compressor at low speed. The High speed ODF will be active when the compressor loader is on, and done by energizing the **ODF SPEED RELAY**.

## LOW AMBIENT OPERATION

When equipped with the head pressure device and the OAT is below approximately 40°F, the ODF speed will vary based on the condensing temperature. Regardless of active low or high speed the head pressure device will modulate the ODF speed to maintain approximately 95°F temperature at the coil sensor location. In low speed operation however the head pressure device cannot use high speed if needed until the control turns on the **ODF SPEED RELAY**.

## Indoor Fan Based Dehumidification

Units can be set for improved dehumidification operation through fan based humidification (FBD), **SETTINGS** → **UNIT CONFIGURATIONS** → **COOLING** → **FAN BASED DEHUM** → **FBD CONTROL TYPE**. Units are factory defaulted to **FBD CONTROL TYPE = 0** which means that any dehum demand is ignored. There are two fan based dehumidification options, Max Comfort (**FBD CONTROL TYPE = 1**) and Max Dehumidification (**FBD CONTROL TYPE = 2**). Fan based dehumidification requires the installation and configuration of either a space relative humidity sensor or a relative humidity switch input.

## MAX DEHUM

When the **FBD CONTROL TYPE** is set to (2) Max Dehum, the control will try to satisfy the dehumidification demand. When the unit receives a dehum demand a PID control algorithm will modulate the indoor fan while the compressor is running to maintain minimum suction temperature (**FBDH\_SST**). The cooling stages will be controlled as normal cooling demand requests, only the IDF will change for dehumidification demand.

## MAX COMFORT

When the **FBD CONTROL TYPE** is set to (1) Max Comfort, the control will try to satisfy the dehumidification demand and minimize cold air dump. When the unit receives a dehum demand a PID control algorithm will modulate the indoor fan while the compressor is running to maintain the minimum FBD supply air comfort set point (**FBDH\_SAT**) while also maintaining the minimum suction temperature (**FBDH\_SST**). The cooling stages will be controlled as normal cooling demand requests, only the IDF will change for dehumidification demand.

## Heating Operation

The unit's heating operation consists of: demand and mode determination, staging request to satisfy the demand, and handling a request with the unit's resources. The unit enters a heating mode based on a demand, decides how to satisfy the demand, executes its plan, and then leaves the heating mode.

## HEATING MODE CONTROL

The heating HVAC mode (**OPERATING MODE**) has 5 different operating sub modes (**SUBMODE**): HEATING, DEFROST, SA TEMPERING, HEATING PREVENTED, and SHUTTING HEAT OFF. These are all part of a general heating mode and resemble the action heat mode is taking at any given time. All types of heating are still performed under the general heating function, and the expanded text is for user reference only. For the unit to be allowed to enter the heat mode, three things must be true: the indoor fan must be ok to use, the mode changeover time guard must be expired, and there must be a heating demand. The unit will remain in heating for at least one minute and until the demand is dropped or if any of the above conditions are false. The heating mode does not officially end

until all heat stages are off, and the fan off delay has expired (**HEAT FANOFF DELAY**).

## SUPPLY-AIR TEMPERATURE SENSOR (SAT) HEAT MODE

The SAT Heat Mode Sensing (**SAT DURING HEAT?**) informs the unit that the supply air sensor is valid during heating in its current location. This configuration affects the Supply Air Temperature (**SUPPLY AIR TEMP**) value displayed as listed below.

When **SAT DURING HEAT?** is disabled, the Supply Air Temperature (**SUPPLY AIR TEMP**) value on the SystemVu display and the network will hold a zero when heat outputs come ON and for 5 minutes after. When **SAT DURING HEAT?** is enabled, the Supply Air Temperature (**SUPPLY AIR TEMP**) sensor reading is displayed at the SystemVu controller and network during heating mode.

## HEATING STAGING CONTROL

Once the unit is in a heating mode, it determines what the demand is and how to satisfy it. To request stages the number of heat stages (**HEATING STAGE QTY**) must be greater than zero. As a heat pump unit this will be set in the factory to 1 stage for mechanical heat, however if accessory electric heat is added in the field this must be updated. If the Outdoor Air Temperature (**OUTDOOR AIR TEMP**) is greater than the Heating Lockout Temp (**HEAT LOCKOUT OAT**), all the heat stages will be locked out (**HEAT LOCKOUT**). The heating check will display if it is ok to heat or not (**OK TO USE HEAT**). Requested Heating Stages (**REQ. HEAT STAGES**) will be determined then passed to heater control to properly add the heating stages.

There are two ways of requesting stages, traditional thermostat control or adaptive control. Traditional thermostat control is used if set for non-adaptive thermostat (**ADAPTIVE TSTAT = NO**) and thermostat control (**UNIT CONTROL TYPE**). If set for adaptive thermostat (**ADAPTIVE TSTAT = YES**), the unit will use adaptive control for staging. When configured for space sensor or RAT control (**UNIT CONTROL TYPE**) the unit will use adaptive control for staging.

With either staging method there are two supply air temperature limits, the Maximum SAT Lower Level (**LOWER MAX SAT**) the Maximum SAT Upper Level (**UPPER MAX SAT**). Any time the supply air temperature rises above lower level the heat staging will be limited to what is currently on and no additional stages will be added until the supply air temperature falls back below the lower level. If the supply air temperature rises above the upper level, then heating will be reduced by removing one stage. That stage will not be added again until the Supply Air Temperature falls below the lower level. If the supply air temperature stays above the upper level, then another stage will be removed. If the upper and lower levels are configured so that they are close together, the last stage of heat might cycle rapidly, slowed only by its minimum on and off-time requirements.

### Adaptive Control

Stage timers and Supply air trend apply when determining the request for stages. The first request (**REQ. HEAT STAGES =1**) comes immediately when starting the staging process. The Heat Stage Increase Time (**HEAT STAGEUP TIME**) must expire and the Supply-Air Trend (**SUPPLY AIR TREND**) must be above the Heating supply air trend level (**HEAT SATTREND LEV**) before another stage can be added. Requested stages will only be allowed to increase as the actual system demand allows (**DEMAND**). A "LOW HEAT" will only allow one requested stage and "HIGH HEAT" 2 stages. The requested stages will be reduced if the heating demand is lowered or dropped completely, or if the supply air falls below the lower level (**LOWER MIN SAT**).

### Traditional Thermostat Control

Stage timers and Supply air trend do not apply when determining the request for stages. Request staging will follow the thermostat inputs directly. "LOW HEAT" will request one stage. "HIGH HEAT" will request 2 stages.

## HEATER CONTROL

Heater control is split into 2 types of heat: Mechanical Heat and Heat Relay control. The specific heat being used at any given time can be seen as the active heat type (**ACTVHEAT SOURCE**) with values of the following: mechanical heating only (**MECH ONLY**), mechanical heat and one stage electric heat (**MECH+1EH**), mechanical heat and two stages of electric heat (**MECH+2EH**), electric heat one stage (**ELCTHT1**), electric heat both stages (**EHI+EH2**), or defrost active (**DEFROST**). Heater control will determine the actual heat stages (**ACTIVE HEAT STAGES**) needed or allowed to satisfy the request. Actual stages can be up to three while the requested stages can only be up to two, this allow 2 stages of electric heat if needed. Refer to Table 13 for a quick look at heating stages, and read below for detailed operation.

### Mechanical Heat Control

When the outdoor temperature is below the mechanical heating lockout (**MEC HEATLOCK TEMP**), mechanical heat will not be allowed to operate, and only electric heat will be used. The availability of the compressors depends on time guards and circuit diagnostics. When mechanical heat is active (**MECH HEAT ACTIVE =Yes**), the control will turn on the liquid line solenoid valve (**LIQUID LINE VALVE**). The liquid line valve will remain on for the configured amount (**LLSV ON TIME**) after ending mechanical heat to help with efficiency and equalization. The reversing valve (**REVERSING VALVE**) is de-energized during mechanical heat. Defrost mode will be turned on as needed to defrost the outdoor coil, refer DEFROST CONTROL section for more details. The compressor and loader will always be run together for mechanical heat as the first heating stage (**ACTIVE HEAT STAGE**).

There are time guards to protect the compressor, Compressor Min On Time (**COMP MIN ON TIME**) and Compressor Min Off Time (**COMP MIN OFF TIME**) apply before the compressor can be turned back on or turned off. Timeguard A1 (**COMP A1 TIMEGUARD**) and Timeguard loader (**COMP LDR TIMEGUARD**) display the time the compressor and loader have before available for use.

Circuit diagnostic tests are performed during operation which may or may not allow the compressor to be used. The availability of the compressor is shown as Compressor A1 Available (**COMP A1 AVAILABLE**). The lockout status of the compressor is shown as Compressor A1 Lockout (**COMP A1 LOCKOUT**). Individual compressor output state is shown as (**COMPRESSOR A1**) and (**COMP A LOADER**). The compressor and circuit diagnostics are the same in heating as they are in cooling except for low suction and unexpected off. Refer to the alarm section for more details.

The outdoor fan state (**ODF STATE**) will always be on and at high speed during mechanical heat. The outdoor fan on/off relay (**ODF ON/OFF RELAY**) is used to turn on and off the fan, and the outdoor speed relay (**ODF SPEED RELAY**) controls the low/high speed of the motor.

### Heat Relay Control

The heat relay control is responsible for energizing or de-energizing the heat stage relays and works hand and hand with

the staging control and mechanical heat control. As the staging control requests stages or mechanical heat is not allowed, the heat relay control determines what actual heat relays are available or energized and tries to provide stages for what is requested. The availability of heat relays depends on the heat installed, how many stages, and time guards. The Number of Heat Stages (**HEATING STAGE QTY**) configuration tells the control how many heat relays can be used. Heat Stage 1 Timeguard (**HEAT 1 TIMEGUARD**) and Heat Stage 2 Timeguard (**HEAT 2 TIMEGUARD**) display the time a respective heat relay has before it can change state. The available stages at any given time are displayed as heat 1 available and heat 2 available (**HEAT 1 AVAILABLE** and **HEAT 2 AVAILABLE**). Heat Stage 1 Relay (**HEAT 1 RELAY**) and Heat Stage 2 Relay (**HEAT 2 RELAY**) are displayed on when the respective relay is energized. There are time guards to protect from short cycling, Heat Minimum On Time (**HEAT MIN ON**) and Heat Minimum Off Time (**HEAT MIN OFF**) apply before a heat relay can be turned back on or turned off.

If equipped, the Heat stage relay 2 (**HEAT 2 RELAY**) may be restricted for energy and comfort. While running mechanical heat (**MECH HEAT ACTIVE =Yes**), heat relay 2 will not operate as the third heat stage until heat relay 1 has been on for 30 minutes. This 30-minute timer is displayed as a delay timer for electric heat 2 (**DELAY FOR EHEAT2**). Also, the third stage heat (**HEAT 2 RELAY**) will be prevented if the outdoor temperature is higher than the 3-stage maximum temperature (**MAX OAT FOR 3STGS**). If mechanical heating is prevented or locked out, the heat relay 2 will be used as a standard second stage. Table 13 provided a quick summary for reference.

## DEFROST CONTROL

Defrost is a sub mode to the heating mode and occurs when ice builds up on the outdoor coil. The defrost switch (**DEFROST SWITCH**) will close when the coil freezes up to its location. When starting up mechanical heat the defrost switch will be ignored for the start defrost delay (**START DEFROST DLY**). There is a wait time the control must wait between defrost cycles (**TIME BTWN DEFROST**), and should be adjusted for the specific location the unit is installed. At any given time, the time between defrost cycles can be checked with the defrost interval timer (**NEXT DEFROST IN**). During mechanical heat, defrost mode will activate (**DEFROST ACTIVE = Yes**) when the defrost switch closes and the time between defrost cycles has expired. The defrost mode will remain active for a minimum of 30 seconds and a maximum based on the max time setting (**MAX DEFROST TIME**) with the active time displayed as **TIME IN DEFROST**. The defrost mode will end at the maximum time limit or when the defrost switch opens. During defrost mode the reversing valve (**REVERSING VALVE**) will be energized putting the unit into cooling but the outdoor fan will be turned off, this will heat the outdoor coil to remove the ice. If equipped with 1 stage electric heat, it will be turned on. If equipped with 2 stage electric heat, the first stage will be turned on and stage 2 will only turn on if the heating demand is High Heat.

Table 13 — Heat Staging Summary

INPUTS				OUTPUTS			
REQ. HEAT STAGES	MECHANICAL HEAT LOCK	HEAT 2 OAT LOCKOUT	DELAY FOR EHEAT 2 expired	MECHANICAL HEAT ACTIVE	HEAT 1 RELAY	HEAT 2 RELAY	ACTIVE HEAT STAGES
0	—	—	—	No	Off	Off	0
1	No	—	—	Yes	Off	Off	1
1	Yes	—	—	No	On	Off	1
2	No	No	No	Yes	On	Off	2
2	No	No	Yes	Yes	On	On	3
2	No	Yes	—	Yes	On	Off	2
2	Yes	—	—	No	On	On	2

— = Logic “don’t care” state

## Supply Air Tempering

Supply air tempering control operates the electric heat to maintain a minimum supply air temperature during conditions where very cold outdoor air causes the supply air temperature to fall below the configured Supply Air Tempering Setpoint. This occurs during periods where DCV is active and increasing the amount of outdoor air or in cases where the system is operating at very low airflow and the calculated economizer position has increased to maintain a constant ventilation rate. The user can enable/disable Supply Air Tempering. The following conditions must be true for the supply air tempering algorithm to operate:

- The unit is equipped with electric heat (**HEATING STAGE QTY** is greater than 1).
- The SA Tempering is set to Yes (**OK TO SA TEMPER = YES**).
- The indoor fan is on.
- The System Mode is in Vent (Ventilation or Supply Fan Only) or IAQ Override.
- The Outdoor Air Temperature < Maximum temperature (**TEMPER MAX OAT**).

If all the above are true, the SystemVu controller will monitor the SAT sensor value and operate the first stage of heat to temper the supply air as required in order to maintain the configured SA Tempering Setpoint.

## Two Position Damper Operation

The two position damper is used for ventilation. If the indoor fan is not on the two position damper will not open. If the two position damper is installed then ventilation method will be set to two position damper (**VENT METHOD = 2POS DMPER (2)**), and two position damper channel will be configured (**2POS/ERV CHANNEL**). When the unit is occupied and the indoor fan is running, the two position damper configured relay will energized. This then activated the motor at the damper to open to the mechanical stop position enforced at the actuator. This will provide the customer set ventilation rate determined for the space.

NOTE: If two position damper is installed with a multiple speed system, the ventilation rate will be high or low depending on the specific speed running during set up and the current speed being run for normal operation.

## Economizer Operation

The economizer is used for ventilation, and cooling. If the indoor fan is not on, the economizer will not operate. If an economizer is installed, then Vent Method (**VENT METHOD = ECON**) should be set to economizer. The unit produces a 4-20mA signal which is then changed to a 2-10V signal with a 500 ohm resistor, which can control the economizer actuator. The economizer output signal is displayed by the Economizer Commanded Position (**ECON CMD POSITION**). The actuator's built-in 2 to 10VDC feedback signal is read in as an analog input to know the actual position which is displayed as Economizer Actual Position (**ECON ACT POSITION**). The economizer system also permits this unit to perform smoke control functions based on external control switch inputs. Refer to the Smoke Control section for detailed discussions.

### MINIMUM VENTILATION

The economizer will open to allow ventilation when the indoor fan is turned on and the unit is in the occupied state. The economizer damper position at any given time for ventilation is displayed as the Min Position in Effect (**EFFECTIVE MIN POS**). This minimum position can be effected by the indoor fan speed (**COMMANDED IDF RPM**) and indoor air quality. To maintain a constant airflow through the economizer, as the indoor fan speed decreases or increases the damper minimum position will increase or decrease, respectively. This relationship curve is shown in Fig. 9.

NOTE: The software point names are used in Fig. 9 as to not clutter the graph. These points are not individually set and therefore only visible from a network for troubleshooting.

These units can also be equipped with optional CO<sub>2</sub> sensors for additional indoor air quality control. When unit is equipped with a return duct CO<sub>2</sub> sensor or return duct CO<sub>2</sub> sensor and outside air CO<sub>2</sub> sensor the economizer minimum position vs. fan speed curve will be recalculated based on the CO<sub>2</sub> level of the return and/or outside air as shown in Fig. 9. When performing Demand Controlled Ventilation, the damper's Min Position in Effect (**EFFECTIVE MIN POS**) will operate in the shaded area of Fig. 9 based on the IAQ Level (IAQ) and the Commanded Fan Speed (**COMMANDED IDF RPM**). See the Indoor Air Quality (IAQ) section for more details on Demand Controlled Ventilation (DCV).

The damper position curve can be field adjusted per application if needed.

1. Activate test mode to control the fan and dampers to achieve the correct numbers.
2. Set the fan speed percentage (%) to the highest speed allowed for building and duct integrity. This is 100% by default and typically left there. If different make sure that the IDF maximum fan speed (**IDF HIGH COOL SPD**) is updated to this tested value.
3. Open the damper to the position which satisfies the highest ventilation requirement running maximum fan speed, and then set the Economizer minimum at maximum fan speed (**MIN POS @ MAX FAN**) to this damper position.
4. Set the fan speed to a realistic operating speed in the upper range, and then set the User Minimum Position Speed 1 (**MIN POS SPEED 1**) equal to that speed. This should be somewhere in the 70% range.
5. Open the damper to the position which satisfies the highest ventilation requirement running speed 1 fan speed, and then set the User Minimum Position Damper Position 1 (**MIN POS DAMP 1**) to this damper position.
6. Set the fan speed to a realistic operating speed in the mid-range, and then set the User Minimum Position Speed 2 (**MIN POS SPEED 2**) equal to that speed. This should be somewhere in the 50% range.
7. Open the damper to the position which satisfies the highest ventilation requirement running speed 2 fan speed, and then set the User Minimum Position Damper Position 2 (**MIN POS DAMP 2**) to this damper position.
8. Set the fan speed to a realistic operating speed in the low-range, and then set the User Minimum Position Speed 3 (**MIN POS SPEED 3**) equal to that speed. This should be lowest fan speed in planned operating range, typically the vent speed.
9. Open the damper to the position which satisfies the highest ventilation requirement running speed 3 fan speed, and then set the User Minimum Position Damper Position 3 (**MIN POS DAMP 3**) to this damper position.

The shape of the curves in Fig. 9 are determined by the configuration parameters: User Minimum Position Speed 1 (**MIN POS SPEED 1**), User Minimum Position Damper Position 1 (**MIN POS DAMP 1**), User Minimum Position Speed 2 (**MIN POS SPEED 2**), User Minimum Position Damper Position 2 (**MIN POS DAMP 2**), User Minimum Position Speed 3 (**MIN POS SPEED 3**), User Minimum Position Damper Position 3 (**MIN POS DAMP 3**), and Economizer minimum at maximum fan speed (**MIN POS @ MAX FAN**). These configurations are preset at the factory of default purposes. The Economizer minimum at maximum fan speed (**MIN POS @ MAX FAN**) should be changed based on the air balance of the unit for proper ventilation.

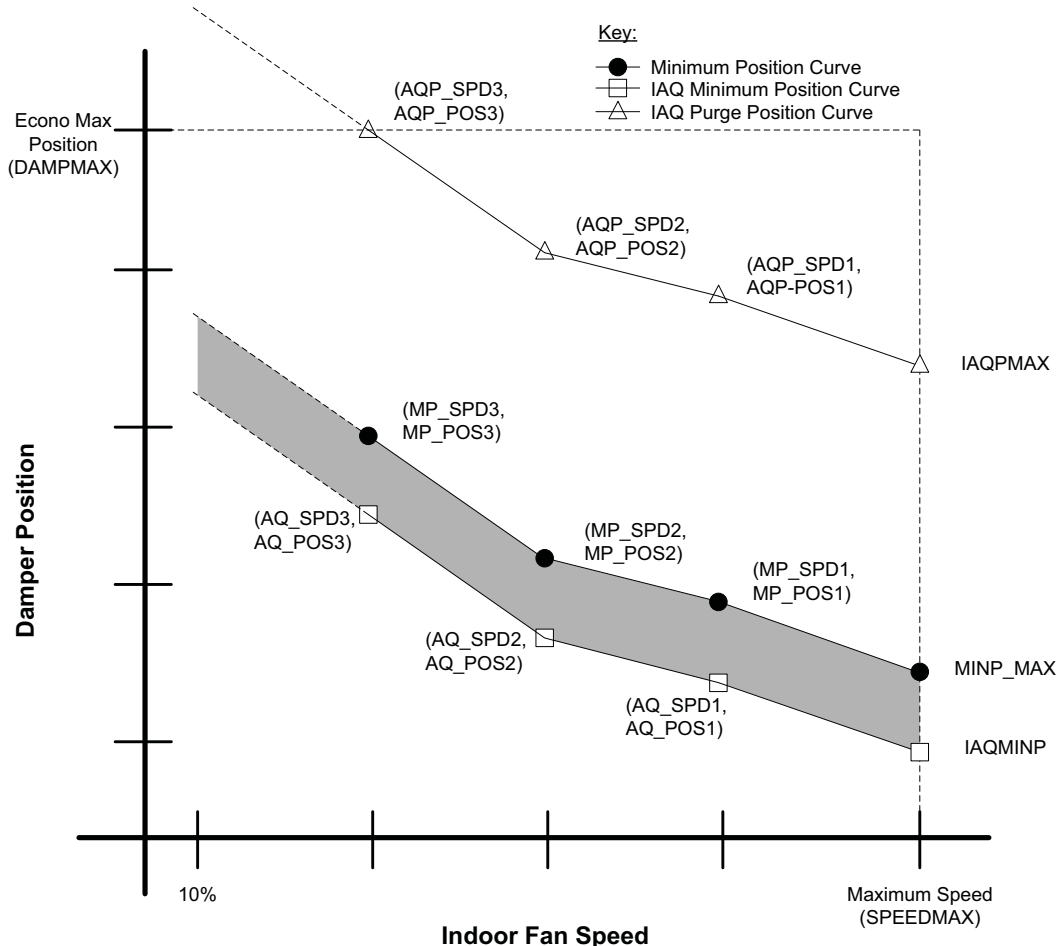


Fig. 9 — Minimum Damper Position Curves

The user adjustable points discussed above are defaulted to zero from the factory which forces the control to use a set of default points. The default points should not be left for permanent operation, as it may cause inadequate ventilation. Economizer minimum at maximum fan speed (*MIN POS @ MAX FAN*) and at least one set of user points User Minimum Position Speed 1 (*MIN POS SPEED 1*) and User Minimum Position Damper Position 1 (*MIN POS DAMP 1*) should be used to create a linear curve to cover the broad scope of fan operation.

### Free Cooling

The economizer will be enabled for cooling (*OK TO FREE COOL? = Yes*) if the supply air temperature sensor reading is valid, there are no applied lockouts, and economizer is operational. Economizer Operational (*ECON OPERATIONAL?*) indicates if an economizer is installed (*VENT METHOD = ECON*) and feedback indicates it is operational. The three economizer lockouts that determine if free cooling should be used to help with cooling are: Dry Bulb Lockout (*DRY BULB LOCKOUT*), Enthalpy Lockout (*ENTHALPY LOCKOUT*), and Unoccupied Free Cooling Lockout (*UFC LOCKOUT?*). Any one of these lockouts will disable economizer free cooling. See below for how each lockout occurs.

When the economizer is available for free cooling (*OK TO FREE COOL? = Yes*) and the compression is not on, the damper will start opening from the damper's minimum Position in Effect (*EFFECTIVE MIN POS*) based on the supply air temperature (*SUPPLY AIR TEMP*) to provide free cooling. A low cooling demand (*DEMAND = LOW COOL*) will utilize the Low Free Cooling SAT Setpoint (*LOW COOL SAT SP*) as the Free Cooling Setpoint (*FREECOOL SAT SP*) to control the economizer. A medium or high cooling demand (*DEMAND = HIGH COOL*) will utilize the

High Free Cooling SAT Setpoint (*HIGH COOL SAT SP*) as the Free Cooling Setpoint (*FREECOOL SAT SP*) to control the economizer.

During free cooling the fan will start at the dedicated free cooling speed (*FREE COOL IDF SPD*). After the economizer (*ECON CMD POSITION*) reaches 100% (or Max) for 5 minutes, the fan will be changed to the High Cool Speed (*HIGH COOL IDF SPD*). When a high cooling demand (*DEMAND = HIGH COOL*) is active the control will use the High Cool Speed (*HIGH COOL IDF SPD*). The compressor will be allowed for use after the fan and economizer are 100% (or Max) for 5 minutes. Once compression is turned on the economizer and fan will remain at 100% until the call for cooling is removed or until the unit is no longer allowed to free cool (*OK TO FREE COOL = No*).

### DRY BULB LOCKOUT

Dry Bulb Lockout (*DRY BULB LOCKOUT*) occurs when any of the following are true:

- The Outdoor Air Temperature (*OUTDOOR AIR TEMP*) is invalid.
- When Differential Dry Bulb Control is disabled (*DIFF DRY BULB CTL = Disable*) and the Outdoor Air Temperature (*OUTDOOR AIR TEMP*) is greater than the configured Free Cooling Maximum Temperature (*FREE COOL MAX OAT*) or less than the configured Free Cooling Minimum Temperature (*FREE COOL MIN OAT*).
- When Differential Dry Bulb Control is enabled (*DIFF DRY BULB CTL = Enable*) and the return air temperature (*RETURN AIR TEMP*) plus the Differential Dry Bulb deadband (*DIFF DB DEADBAND*) is lower than the outdoor air temperature (*OUTDOOR AIR TEMP*).

## ENTHALPY LOCKOUT

The control uses the Outdoor Air Temperature (*OUTDOOR AIR TEMP*), Outdoor Relative Humidity (*OARH LEVEL*), and Barometric Pressure (*BAROMETRIC PRESS*) to calculate the Outdoor Enthalpy (*OUTDOOR ENTHALPY*). The control uses the Return Air Temperature (*RETURN AIR TEMP*), Return Relative Humidity (*RARH LEVEL*), and Barometric Pressure (*BAROMETRIC PRESS*) to calculate the Return Enthalpy (*RETURN ENTHALPY*). Enthalpy Lockout (*ENTHALPY LOCKOUT*) occurs when any of the following are true:

- When Differential Enthalpy Control is disabled (*DIFF ENTHALPY CTL = Disable*) and the outdoor enthalpy (*OUTDOOR ENTHALPY*) is greater than the Maximum Outdoor Enthalpy limit (*ENTHALPY HI LIMIT*).
- When Differential Dry Bulb Control is enabled (*DIFF DRY BULB CTL = Enable*) and the outdoor enthalpy (*OUTDOOR ENTHALPY*) is greater than the return enthalpy (*RETURN ENTHALPY*). The Differential Enthalpy deadband (*ENTHALPY DEADBAND*) is used in the case of unlocking the Enthalpy lockout (*ENTHALPY LOCKOUT*).
- The Enthalpy switch input (*ENTHALPY SWITCH*) is reading high.

## UNOCCUPIED FREE COOLING LOCKOUT

Unoccupied Free Cooling lockout (*UFC LOCKOUT?*) occurs when the unit is in the unoccupied period (*OCCUPIED NOW? = No*) and the Outdoor Air Temperature (*OUTDOOR AIR TEMP*) is less than the Unoccupied Free Cooling low temperature (*UFC LOW TEMP*).

### Unoccupied Free Cooling

The unoccupied free cooling algorithm attempts to maintain the building space half way between the Occupied Cool Set Point (*OCC COOL SETPOINT*) and Occupied Heat Set Point (*OCC HEAT SETPOINT*) using only the economizer when the conditions in the building and the outdoors are suitable, during unoccupied periods. Three different points define this algorithm: Unoccupied Free Cooling configuration (*WHEN TO UNOCC FC*), Free Cooling Preoccupancy Time configuration (*UFC PREOCC TIME*), and Free cooling allowed (*OK TO FREE COOL?*).

**WHEN TO UNOCC FC = 0 (Disabled)**

Free Cooling will only occur if the space exceeds the unoccupied setpoints.

**WHEN TO UNOCC FC = 1 (Preoccupancy)**

Unoccupied free cooling can only occur when the time until the next occupied period is less than the Unoccupied Free Cool Pre-Occupancy Time (*UFC PREOCC TIME*) in minutes.

**WHEN TO UNOCC FC = 2 (Unoccupied)**

Unoccupied free cooling can occur throughout the entire unoccupied period. The space temperature must be higher than the mid-point between the occupied cooling and heating setpoints.

### Power Exhaust

Power Exhaust is a function used to assist in the building exhaust air if the barometric relief damper is not enough. It can be one or two motors which can be controlled independently to provide 2 stages of exhaust. These two power exhaust stages are controlled by relays on the Main Base board, and therefore need to be configured on relay channels. To assign the channels set the *PE1 RELAY CHANNEL* and *PE2 RELAY CHANNEL* as needed.

NOTE: Factory installed power exhaust is only one channel and is on Relay 06.

When a power exhaust 1 relay channel is configured, the control will create a PE1 curve, example shown in Fig. 10. This curve is created by applying the difference of the power exhaust stage 1 at maximum fan speed (*PE1 POS @ MAX SPD*) and the

Economizer minimum at maximum fan speed (*MIN POS @ MAX FAN*) in relationship to the minimum position curve. When a power exhaust 2 relay channel is configured, the control will create a PE2 curve, example shown in Fig. 10. This curve is created by applying the difference of the power exhaust stage 2 at maximum fan speed (*PE2 POS @ MAX SPD*) and the Economizer minimum at maximum fan speed (*MIN POS @ MAX FAN*) in relationship to the minimum position curve.

Power exhaust 1 (*PE1 RELAY*) and power exhaust 2 (*PE2 RELAY*) are controlled using their respective curves as a threshold. When the operating point of the Commanded Fan Speed (*IDF SPEED OUTPUT*) and Economizer Commanded Position (*ECON CMD POSITION*) is above the power exhaust 1 curve, the Power exhaust 1 (*PE1 RELAY*) will be turned on. When the operating point falls below the curve minus the power exhaust turn off deadband (*PE OFF DEADBAND*) the Power exhaust 1 (*PE1 RELAY*) will be turned off. Power exhaust 2 operates the same as Power exhaust 1 except using the PE2 curve.

### Indoor Air Quality (IAQ)

Indoor air quality is typically measured using a CO<sub>2</sub> sensor whose measurements are displayed in parts per million (ppm). Outdoor air quality may be measured with a CO<sub>2</sub> sensor for indoor-outdoor differential demand ventilation control. The factory-installed indoor air quality CO<sub>2</sub> sensor is mounted in the return section. A field-installed indoor air quality CO<sub>2</sub> sensor may be mounted in the return or in the occupied space. The indoor air quality modes of operation can be affected by the IAQ Analog Input Config (*ANALOG IAQ CTRL*) and other related and limit configurations as described below.

#### IAQ (ANALOG INPUT)

When IAQ assigned channel (*IAQ SENSOR CHAN*) is set for an analog input that input channel will be mapped to the Indoor Air Quality (*IAQ LEVEL*). The control is configured for indoor air quality sensors which provide 4 to 20 mA signal for 0 to 2000 ppm CO<sub>2</sub>. If the sensor being used has a different range, the ppm display range must be reconfigured by entering new values for the IAQ Sensor Value at 4mA (*IAQ PPM @ 4MA*) and IAQ Sensor Value at 20mA (*IAQ PPM @ 20MA*).

**ANALOG IAQ CTRL = 0 (No IAQ)**

This signifies that there is no IAQ sensor installed. The economizer damper will operate based on the minimum position curve.

**ANALOG IAQ CTRL = 1 (DCV)**

During Demand Controlled Ventilation (DCV), the damper modulates on or between two ventilation curves depending upon the difference between the Indoor Air Quality (*IAQ LEVEL*) and the Outdoor Air Quality (*OAQ LEVEL*). The lower of these two curves is referred to as the IAQ Minimum Position Curve, and the higher curve is the Minimum Position curve discussed in the Minimum Ventilation section under Economizer Operation. Refer to that section on how the minimum Position curve is created. See Example Curves in Fig 9.

The IAQ Minimum Position curve is created by applying the difference of the IAQ position at maximum fan speed (*IAQ POS @ MAX SPD*) and the Economizer minimum at maximum fan speed (*MIN POS @ MAX FAN*) in relationship to the minimum position curve. The IAQ position at maximum fan speed (*IAQ POS @ MAX SPD*) should be set to an economizer position that brings in enough fresh air to remove contaminants and CO<sub>2</sub> generated by sources other than people. The Economizer minimum at maximum fan speed (*MIN POS @ MAX FAN*) should be set to an economizer position that brings in fresh air to remove contaminants and CO<sub>2</sub> generated by all sources including people when the indoor fan is operating at the IDF Maximum Fan Speed (*MAXIMUM IDF SPEED*). The Economizer minimum at maximum fan speed (*MIN POS @ MAX FAN*) value is the design value for maximum occupancy.

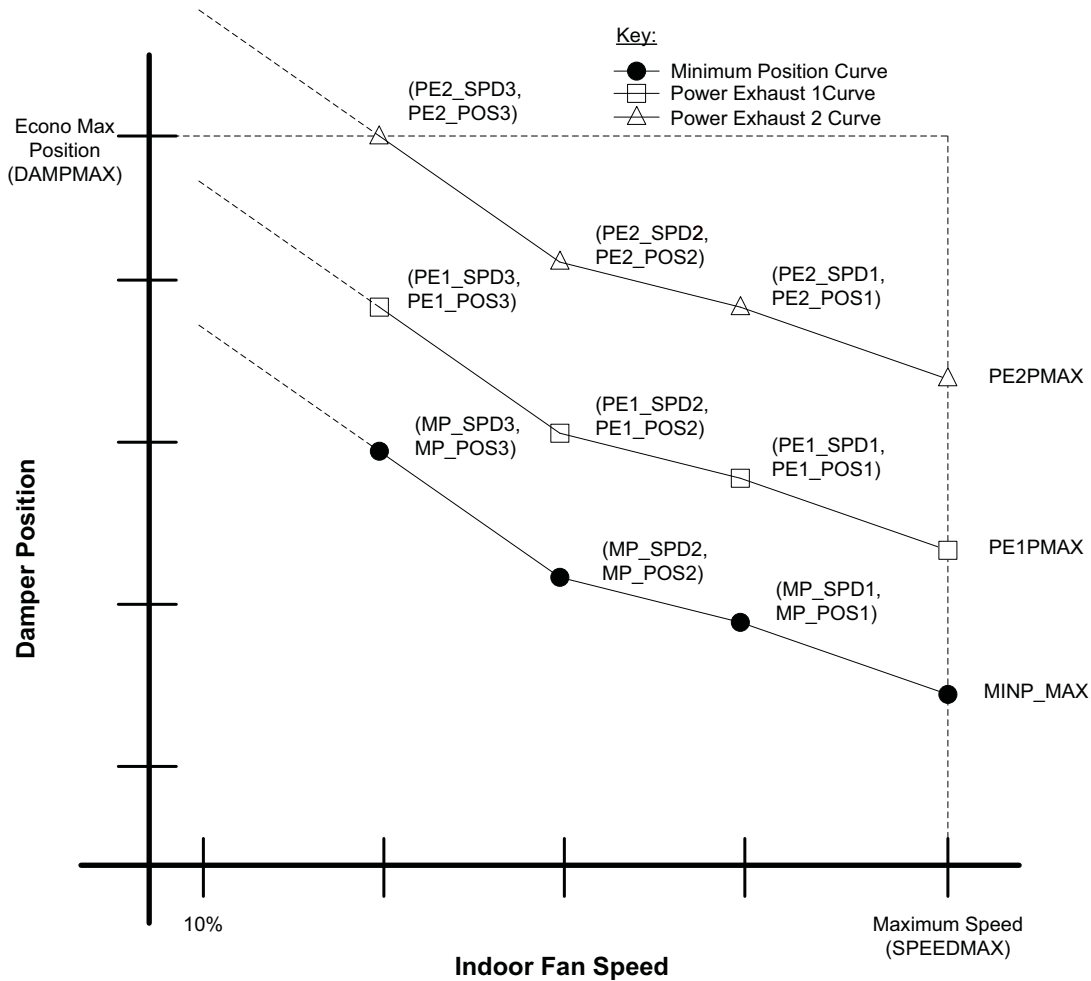


Fig. 10 — Power Exhaust Operation Curves

The economizer Min Position in Effect (**EFFECTIVE MIN POS**) will follow the IAQ Minimum Position curve while the Indoor Air Quality level (**IAQ LEVEL**) is less than the Outdoor Air Quality Level (**OAQ LEVEL**). The control will begin to open the damper more than the IAQ Minimum Position curve when the IAQ level begins to exceed the OAQ level by a configurable amount. This amount is referred to as AQ Differential Low (**LOW AIR.Q DIFF**). When the differential between IAQ and OAQ reaches AQ Differential High (**HIGH AIR.Q DIFF**), the economizer Min Position in Effect (**EFFECTIVE MIN POS**) will follow the Minimum Position Curve. When the IAQ/OAQ differential is between AQ Differential Low (**LOW AIR.Q DIFF**) and AQ Differential High (**HIGH AIR.Q DIFF**), the control will modulate the damper between the IAQ Minimum Position Curve and the Minimum Position Curve in a linear manner as shown as the shaded area in Fig. 9. As a simple example Fig. 11 shows the Min Position in Effect (**EFFECTIVE MIN POS**) relationship while the Commanded Fan Speed (**ECON CMD POSITION**) is held at the maximum speed.

**ANALOG IAQ CTRL = 2 (Override IAQ)**

Override IAQ is reserved for a future release.

**ANALOG IAQ CTRL = 3 (Control Minimum Position)**

An external 4 to 20 mA source is used to set the Min Position in Effect (**EFFECTIVE MIN POS**). The 4mA signal corresponds to 0% and the 20 mA signal corresponds to 100%. In this mode, configuration such as Economizer minimum at maximum fan speed (**MIN POS @ MAX FAN**), IAQ position at maximum fan speed (**IAQ POS @ MAX SPD**) and the economizer minimum

position and DCV minimum position curves in Fig. 9 and Fig. 11 are not used. If the indoor fan is not operating, the economizer position will be zero. The actual damper position may exceed the economizer Min Position in Effect (**EFFECTIVE MIN POS**) to provide economizer cooling.

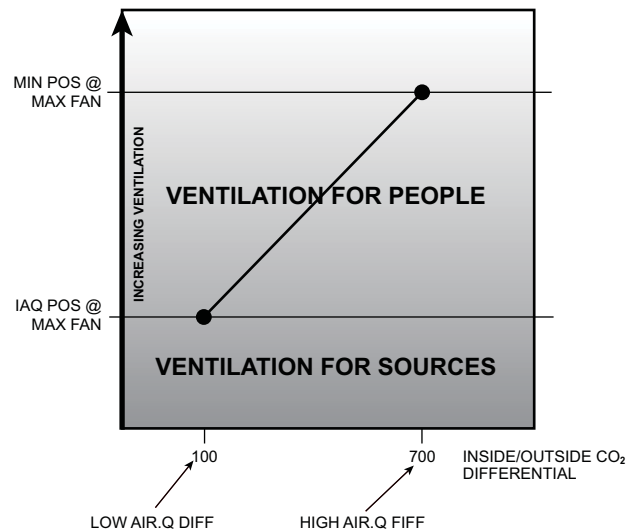


Fig. 11 — Example



## OUTDOOR AIR QUALITY (ANALOG INPUT)

The default for the Outdoor Air Quality (**OAQ LEVEL**) is 400 ppm CO<sub>2</sub> when the OAQ sensor is not assigned an input channel. When OAQ Assigned channel (**OAQ SENSOR CHAN**) is set for an analog input that input channel will be mapped to the Outdoor Air Quality (**OAQ LEVEL**). The outdoor air quality sensor provides a 4 to 20 mA signal corresponding to 0 to 2000 ppm CO<sub>2</sub>. If a field supplied sensor has a different range, the ppm display range must be reconfigured by entering new values for the OAQ Sensor Value at 4mA (**OAQ PPM @ 4MA**) and OAQ Sensor Value at 20mA (**OAQ PPM @ 20MA**).

## Pre-occupancy Purge

The control has the option for a pre-occupancy purge to refresh the air in the space prior to occupancy. This feature is enabled by setting **PREOCC PURGE ENBL** to Yes. This function is also referred to as the IAQ purge function.

The IAQ Purge will operate under the following conditions:

- Purge is enabled
- the unit is in the unoccupied state
- Current Time is valid
- Next Occupied Time is valid
- time is one hour prior to next occupied period
- the OAT is greater than the lockout (**PREOCC LOW LIMIT**)

The IAQ Purge Position curve is created by applying the difference of the IAQ purge position at maximum fan speed (**PURGE POS @ MAX**) and the Economizer minimum at maximum fan speed (**MIN POS @ MAX FAN**) in relationship to the minimum position curve. The IAQ purge position at maximum fan speed (**PURGE POS @ MAX**) should be set to an economizer position that brings in enough fresh air over an hour period to remove contaminants and CO<sub>2</sub> during the unoccupied period. When the preoccupancy purge function is active (**IN PREOCC PURGE?**), the economizer Min Position in Effect (**EFFECTIVE MIN POS**) will follow the IAQ Purge Position curve.

## Temperature Compensated Start

Space control set points are usually set to 2 different levels for unoccupied period and occupied period. Unoccupied set points saves energy, while occupied set points provide occupant comfort. The time period it takes for the RTU to bring the space from its current condition in unoccupied mode to its occupied set point is referred to as start bias time, or bias time. The algorithm to calculate this bias time is called Temperature Compensated Start. This is required for ASHRAE 90.1 compliance. When temperature compensated start is running (**TCS ACTIVE?**) the control uses the occupied set points to control the space.

When Temperature compensated start is enabled (**ADAPTIVE TCS?**), no other configuration parameters are needed for this algorithm, because the algorithm will automatically adjust the Bias Time based on the data collected during the period of last time optimal start. The inputs to the calculation algorithm includes space temperature, unoccupied set points, occupied set points, outdoor air temperature, and supply air temperature. Bias time is changed dynamically per RTU operation.

When Temperature compensated start is disabled (**ADAPTIVE TCS?**), the control will use the User Temperature compensated Start bias time (**USER TCS BIASTIME**) in determining when to start controlling to the occupied set points. If the User Temperature compensated Start bias time (**USER TCS BIASTIME**) is set to zero, the control will switch to the occupied setpoints at the time of occupancy.

## Smoke Control

There are four smoke control modes that can be used to control smoke within areas serviced by the unit: Pressurization mode, Evacuation mode, Smoke Purge mode, and Fire Shutdown.

Evacuation, Pressurization and Smoke Purge modes are post event clean up modes, while Fire Shutdown is a detection and prevention mode. All four functions are configurable on any of the switch input channels. These functions can also be triggered through building commands. Refer to the Configurable Inputs and Outputs section for more details on inputs.

Multiple smoke inputs are handled in a priority scheme. Fire Shutdown is the highest priority and will override all other smoke control. The three other modes are in the following priority order: Evacuation, Purge, then Pressurization.

## FIRE SHUTDOWN MODE

This mode will cause an immediate and complete shutdown of the unit.

## EVACUATION MODE

This mode attempts to lower the pressure of the space to prevent infiltrating an adjacent space with its smoke. Closing the economizer (thereby opening the return air damper), turning on the power exhaust and shutting down the indoor fan decrease pressure in the space.

## SMOKE PURGE MODE

This mode attempts to draw out smoke from the space after the emergency condition. Opening the economizer (thereby closing the return-air damper), turning on both the power exhaust and indoor fan will evacuate smoke and bring in fresh air.

## PRESSURIZATION MODE

This mode attempts to raise the pressure of a space to prevent smoke infiltration from an adjacent space. Opening the economizer (thereby closing the return air damper), shutting down power exhaust and turning the indoor fan on will increase pressure in the space.

## Airflow Control During the Fire/Smoke Modes

All non-smoke related control outputs will get shut down in the fire/smoke modes. Those related to airflow will be controlled as explained below. The following matrix specifies all actions the control shall undertake when each mode occurs.

Device	Fire Shutdown	Evacuation	Purge	Pressurization
Economizer	Off	EVAC WITH DAMPER*	100% open	100% open
Power Exhaust 1 and 2	Off	On	On	Off
Indoor Fan	Off	Off	IDF MAX SPEED	IDF MAX SPEED
All other components	Off	Off	Off	Off

\* **SETTINGS** → **UNIT CONFIGURATIONS** → **GENERAL** → **EVAC WITH DAMPER** is a unit configuration that determines what the economizer damper does during the Evacuation smoke control mode. When set to yes the damper will open during Evacuation mode. When set to no, the damper will be closed during Evacuation mode.

NOTE: The importance of the EVAC WITH DAMPER setting depends on the intent of the Evacuation function. The tradition building Evacuation mode would be best with the off as it is using other spaces pressurization to help move the air. To truly help evacuate the direct space this setting should be yes.

## Linkage

The SystemVu controller will support 3V, VAV and VVT zoning system on a CCN system or Open VVT and VAV systems on a BACnet MS/TP System. All that is required is to configure the Open or 3V Master zone to use the SystemVu rooftop unit as its air source. The SystemVu control will need to be configured for the proper network protocol (**BAS PROTOCOL**) and set for Space Sensor Control (**UNIT CTRL TYPE**). The SystemVu controller will reply to the zoning system and change its operating parameters to meet the demand of the

zoning system. Status of this process can be viewed in the air-side linkage tab of the property pages in the i-Vu application or by viewing the linkage maintenance table with a CCN tool.

### Carrier Comfort Network (CCN) Operation

The SystemVu controller can be configured to connect to a CCN system. The SystemVu controller has one RS-485 BMS port that can be configured from the local display for BACnet or CCN. The BMS configuration parameters can be found in the **SETTINGS** → **NETWORK SETTINGS** submenu. The first configuration is the BMS system for CCN systems change this configuration from BACnet to CCN then set the CCN BAUD rate, the bus and element number and you will be able to find the controller with any CCN tool then upload the CCN tables in the controller for use by the tool.

### BACnet Network Operation

The SystemVu controller is ready to connect to BACnet. The SystemVu controller has one RS-485 BMS port that can be configured from the local display for BACnet or CCN. The default setting is BACnet and the Default BACnet Baud rate is 76800. These settings are found on the **SETTINGS** → **NETWORK SETTINGS** submenu of the local display. There are four other settings for i-Vu compatibility and for setting the device ID and MAC address of the controller. See the table below for assistance.

Before connecting to the BACnet system determine the system requirements and use the following guide to configure the BACnet settings. Then power the controller down, connect to the BACnet MS/TP network and you are ready to discover your controller.

For i-Vu systems with auto addressing desired the controller is already set with the defaults from the factory ready to connect to this type of system; just set the MAC address of the controller from 0 to 99 and then power down and connect to the network. The router will find and send the network number to the controller and the controller will set it device ID with the network base appended by the Mac address.

For i-Vu and other BACnet systems when it is required to send the device ID to the controller change the ALC/i-Vu auto ID scheme to no and set the MAC address from 0 to 99 like before. Then connect to the network and write the device ID to the controller at the MAC address you set. The controller will accept and retain the device ID written to the device ID property of the object ID.

To manually set the device ID from the local display set the BACnet auto/manual to manual. This allows use of the full range of 1 to 127 for the MAC address and set the device ID in the BACnet ID selection of the local display. It can only be set from the local display and will not accept a write to the device ID property in the object ID.

BACnet ID Auto/Manual	i-Vu Auto Scheme	How Device is derived	MAC range
Manual	ON or OFF	Local display BACnet Id-BACNet Writes not allowed	0-127
Auto	OFF	Device Id Prefix + Mac - BACnet writes allowed	0-99
Auto	ON	Device Id Prefix + MAC (prefix updated by color cache) - BACnet writes not allowed	0-99

### Alarm Handling

There are a variety of different alerts and faults in the system, the term alarm is used to reference alerts and faults. Alerts are indicated by AXXX (where XXX is the alert number) on the display and generally signify a warning of some sort or the improperly functioning circuit can restart without human interaction. If a fault occurs, indicated by FXXX (where XXX is the fault number), a major function of the unit is inoperable or the

damaged circuit will generally not restart without an alarm reset via the display or CCN.

The response of the control system to various alerts and faults depends on the seriousness of the particular alert or fault. In the mildest case, an alert does not affect the operation of the unit in any manner. An alert can also cause a “strike.” A “striking” alert will cause the circuit to shut down for 15 minutes. This feature reduces the likelihood of false alarms causing a properly working system to be shut down incorrectly. If three strikes occur before the circuit has an opportunity to show that it can function properly, the circuit will strike out, causing the shut-down fault for that particular circuit. Once activated, the shut-down fault can only be cleared via an alarm reset.

However, circuits with strikes will be given an opportunity to reset their strike counter to zero. As discussed above, a strike typically causes the circuit to shut down. Fifteen minutes later, that circuit will once again be allowed to run. If the “troubled” circuit runs continuously for a user defined time (**SETTINGS** → **UNIT CONFIGURATIONS** → **COOLING** → **STRIKE CLEAR TIME**) with no detectable problems the strike counter will be reset to zero. Default value is 5 minutes.

### ALARM RELAY OUTPUT

The alarm relay output is a configurable normally open 24-VAC output defaulted to relay 11 on the Main Base Board (MBB) TB2 connector. Selection of which alerts and faults will result in closing of the alarm relay may be set in the Alarm Relay Configuration (**SETTINGS** → **UNIT CONFIGURATIONS** → **ALARM RELAY**). Setting a configuration to YES will result in the alarm output relay to energize when that particular condition is in an alarm state. Setting a configuration to NO will result in no action by the alarm output relay for that particular condition.

NOTE: An accessory filter switch can be used along with the alarm relay output function to indicate dirty filter service need. See the Troubleshooting section for more information on viewing, diagnosing, and clearing alerts and alarms.

## TROUBLESHOOTING

The SystemVu display shows actual operating conditions of the unit while it is running. If there are alarms or there have been alarms, they will be displayed in either the active faults, active alerts, or the history alarm list (see Table 14 starting on page 31). Service Test mode allows proper operation of the compressors, fans, and other components to be checked while the unit is not operating. See Service Test (on page 11).

### Complete Unit Stoppage

There are several conditions that can cause a complete unit stoppage, including:

- A fault is active which causes the unit to shut down.
- Cooling and heating loads are satisfied.
- Programmed occupancy schedule.
- General power failure.
- Tripped 24-volt transformer circuit breakers.
- Blown fuse or circuit breakers
- Unit is turned off through the network.

### Restart Procedure

Before attempting to restart the machine, check the faults and alerts list to determine the cause of the shut down. If the shut-down fault for a particular control function has occurred, determine and correct the cause before allowing the unit to run under its own control again. When there is problem, the unit should be diagnosed in Service Test mode. The faults must be reset before the control function can operate in either Normal mode or Service Test mode.

## Faults and Alerts

### VIEWING AND CLEARING UNIT ALARMS

Presence of active alarms will be indicated on the SystemVu display by the Alarm Status lights. When alerts are active the yellow "ALERT" light will be lit. When faults are active the red "FAULT" light will be lit. When the unit is operational, then green "RUN" light will be lit. The SystemVu controller standby screen will be updated with the active alarms for easy access. Presence of active alarms may also be signaled on the Alarm Output terminals. Each alarm may also be broadcast on the CCN network. Active alarms and past alarm history can be reviewed and cleared via the local display or a network device. The following menu locations are used for the local display:

#### **ACTIVE FAULTS**

Displays the list of active faults in order of occurrence.

#### **ACTIVE ALERTS**

Displays the list of active alerts in order of occurrence.

#### **HISTORY**

Displays the list of active and previously active faults and alerts in order of occurrence with time and date.

#### **RESET FAULTS/ALERTS**

User command to manually reset faults and alerts.

Each alarm can have up to 3 data points stamped along with date and time to assist in troubleshooting. Pressing ENTER on the alarm or expanded screen will provide these data points.

### DIAGNOSTIC ALARM CODES AND POSSIBLE CAUSES

#### **Fault F010 — MBB LOW VOLTAGE**

This fault occurs when the MBB supply voltages falls below 17 volts AC. When this occurs the control will shut down the unit. This will automatically clear when the supply voltage rises above 19 volts AC. The cause of this fault is usually a brownout condition, low supply voltage, or supply power missing a phase.

#### **Fault F011 – MBB REFERENCE VOLTAGE**

This fault occurs when the MBB internal microprocessor's DC reference voltages is out of range. When this occurs the control will shut down the unit. This will automatically clear when the DC reference voltage goes back in range. The cause of this fault is usually a MBB failure or supply voltage out of range.

#### **Alert A012 – MBB ZERO CROSSING**

This fault occurs when the MBB supply voltage frequency is out of range. When this occurs the control will issue an alert. This will automatically clear when the supply voltage goes back in range. The cause of this fault is usually a MBB failure or supply voltage frequency to high or to low.

#### **Fault F013 – MBB FUSE 2 OPEN**

This fault occurs when the MBB's internal fuse number 2 exceeds threshold temperature. When this occurs the control will shut down the unit. This will automatically clear when the fuse temperature gets back in range. The cause of this fault is usually a switch input has a wiring error (short) or the switch pulled too much current. Discrete input number 2 and Fire Shutdown input are connected to fuse 2.

#### **Fault F014 – MBB FUSE 3 OPEN**

This fault occurs when the MBB's internal fuse number 3 exceeds threshold temperature. When this occurs the control will shut down the unit. This will automatically clear when the fuse temperature gets back in range. The cause of this fault is usually a switch input has a wiring error (short) or the switch pulled too much current. Configurable discrete input numbers 12, 13, and 14 are connected to fuse 3.

#### **Alert A015 – MBB RNET VOLTAGE RANGE**

This fault occurs when the MBB's Rnet 12 volt output is out of range. When this occurs the control will issue an alert, and any accessory connected to the Rnet plug may not operate properly. This will automatically clear when the voltage goes back in range. The cause of this fault is usually a MBB failure or supply voltage out of range.

#### **Alert A016 – MBB 24VDC RANGE**

This fault occurs when the MBB's 24vdc output falls below 17 volts DC. When this occurs the control will put the Analog Input number's 6, 7, and 8 into error state. This will automatically clear when the voltage rises above 19 volts DC. The cause of this fault is usually a MBB failure or supply voltage out of range.

#### **Alert A017 – MBB 5VDC RANGE**

This fault occurs when the MBB's 5vdc output falls below 4.5 volts DC. When this occurs the control will put the Transducer inputs into error state. This will automatically clear when the voltage rises above 4.5 volts DC. The cause of this fault is usually a MBB failure or supply voltage out of range.

#### **Fault F018 – MBB EEPROM FAILURE**

The unit will completely shut down. The serial EEPROM chip on the MBB which stores the unit's configuration is not responding. Recovery is automatic but MBB board replacement may be necessary. Cycling the power to the control should be tried before board replacement.

#### **Alert A019 – MBB CLOCK FAILURE**

The alert occurs when the RTC clock chip on the MBB is not responding. Time and date functions will not operate, such as local occupancy schedules. The unit will default to 24/7 unoccupied mode. Recovery is automatic but MBB board replacement may be necessary. Cycling power to the control and reconfiguring the time and date should be tried before board replacement.

#### **Fault F020 – SOFTWARE ERROR**

The unit will completely shut down. The software on the MBB is not responding. Recovery is automatic if the software is able to reset the board but software change may be necessary. Cycling the power to the control should be tried before board replacement.

#### **Alert A100 – SAT SENSOR FAILURE**

This alert occurs when the fan supply temperature sensor is in an error state. Economizer cooling cannot occur while this alert is active. The unit will not be able to honor SAT limits. This alert resets automatically. The cause of the alert is usually a faulty thermistor, a shorted or open thermistor caused by a wiring error, or a loose connection.

#### **Alert A101 – FST SENSOR RANGE**

This alert occurs when the fan supply temperature sensor is outside the range -40°F to 245°F (-40°C to 116°C). This alert resets automatically. The cause of the alert is usually a faulty thermistor, a shorted or open thermistor caused by a wiring error, or a loose connection.

#### **Alert A102 – FST OPEN SENSOR**

This alert occurs when the fan supply temperature sensor reads as an open circuit. This alert resets automatically. The cause of the alert is usually a faulty thermistor or an open thermistor caused by a wiring error, or a loose connection.

#### **Alert A103 – FST SHORTED SENSOR**

This alert occurs when the fan supply temperature sensor reads as a short circuit. This alert resets automatically. The cause of the alert is usually a faulty thermistor or a shorted thermistor caused by a wiring error, or a loose connection.

#### **Alert A104 – OAT SENSOR RANGE**

This alert occurs when the outdoor air temperature is outside the range -40°F to 245°F (-40°C to 116°C). All ambient temperature lockout limits for cooling and heating are ignored. All cooling control logic will assume OAT is high. For economizer

equipped units, the economizer will not operate to provide cooling. The economizer will still operate for ventilation. The control will use normal operation for outdoor fan control. For units with CCH crankcase heat relay control, the crankcase heat relay will be turned on if any compressor is off. This alert resets automatically. The cause of the alert is usually a faulty thermistor, a shorted or open thermistor caused by a wiring error, or a loose connection.

**Alert A105 – OAT OPEN SENSOR**

See Alert A104

**Alert A106 – OAT SHORTED SENSOR**

See Alert A104

**Alert A107 - RAT SENSOR RANGE**

This alert occurs when the return air temperature is outside the range -40°F to 245°F (-40°C to 116°C). Differential dry bulb crossover control can not occur. Free cooling can only be controlled by the OAT and enthalpy switch. The economizer mechanically disconnected alert will not be diagnosed. This alert resets automatically. The cause of the alert is usually a faulty thermistor, a shorted or open thermistor caused by a wiring error, or a loose connection.

**Alert A108 – RAT OPEN SENSOR**

See Alert A107

**Alert A109 – RAT SHORTED SENSOR**

See Alert A107

**Alert A110 – SPT SENSOR RANGE**

This alert occurs when the temperature is outside the range -40°F to 245°F (-40°C to 116°C). Cooling and heating will not operate. For economizer equipped units, the economizer will still operate for ventilation. This alert resets automatically. The cause of the alert is usually a faulty thermistor in the T-55, T-56, or T-58 device, a shorted or open thermistor caused by a wiring error, or a loose connection.

**Alert A111 – SPT OPEN SENSOR**

See Alert A110

**Alert A112 – SPT SHORTED SENSOR**

See Alert A110

**Alert A130 – CIR.A SSP SENSOR RANGE**

This alert occurs when the pressure is outside the range -6.7 to 420 psig. A circuit cannot run when this alert is active. The cause of the alert is usually a faulty transducer, faulty 5-v power supply, or a loose connection. Use the transducer voltage drop table to determine where the error is introduced.

**Alert A131 – CIR.A SSP OPEN SENSOR**

See Alert A130

**Alert A132 – CIR.A SSP SHORT SENSOR**

See Alert A130

**Alert A133 – CIR.A SDP SENSOR RANGE**

This alert occurs when the pressure is outside the range 14.5 to 667 psig. A circuit cannot run when this alert is active. The cause of the alert is usually a faulty transducer, faulty 5-v power supply, or a loose connection. Use the transducer voltage drop table to determine where the error is introduced.

**Alert A134 – CIR.A SDP OPEN SENSOR**

See Alert A133

**Alert A135 – CIR.A SDP SHORT SENSOR**

See Alert A133

**Alert 150 - OACFM OPEN SENSOR**

This alert occurs when the Outdoor Air CFM sensor input is 0 mA and the sensor is configured and installed. Check sensor and wiring. This alert clears automatically.

**Alert 151 - OACFM SHORTED SENSOR**

This alert occurs when the Outdoor Air CFM sensor input shorted and the sensor is configured as installed. Check sensor and wiring. This alert clears automatically.

**Alert A160 – OARH OPEN SENSOR**

This alert occurs when the Outdoor Air Relative Humidity sensor input is 0 mA and the sensor is configured as installed. Outside Air Enthalpy cannot be calculated therefore no enthalpy crossover can be used and only dry bulb will be used in determining free cooling. Check sensor and wiring. This alert clears automatically.

**Alert A161 – OARH SHORTED SENSOR**

This alert occurs when the Outdoor Air Relative Humidity sensor input shorted and the sensor is configured as installed. Outside Air Enthalpy cannot be calculated therefore no enthalpy crossover can be used and only dry bulb will be used in determining free cooling. Check sensor and wiring. This alert clears automatically.

**Alert A162 – RARH OPEN SENSOR**

This alert occurs when the Return Air Relative Humidity sensor input is 0 mA and the sensor is configured as installed. Return Air Enthalpy cannot be calculated therefore no differential enthalpy crossover can be used. Dry bulb and single enthalpy will be used in determining free cooling. Check sensor and wiring. This alert clears automatically.

**Alert A163 – RARH SHORTED SENSOR**

This alert occurs when the Return Air Relative Humidity sensor input shorted and the sensor is configured as installed. Return Air Enthalpy cannot be calculated therefore no differential enthalpy crossover can be used. Dry bulb and single enthalpy will be used in determining free cooling. Check sensor and wiring. This alert clears automatically.

**Alert A164 - IAQ OPEN SENSOR**

This alert occurs when the IAQ input is 0 mA and the sensor is configured as installed. IAQ operation will be disabled. Check sensor and wiring. This alert clears automatically.

**Alert A165 - IAQ SHORTED SENSOR**

This alert occurs when the IAQ input is shorted and the sensor is configured as installed. IAQ operation will be disabled. Check sensor and wiring. This alert clears automatically.

**Alert A166 - OAQ OPEN SENSOR**

This alert occurs when the OAQ input is 0 mA and the sensor is configured as installed. OAQ operation will be disabled. Check sensor and wiring. This alert clears automatically.

**Alert A167 - OAQ SHORTED SENSOR**

This alert occurs when the OAQ input is shorted and the sensor is configured as installed. OAQ operation will be disabled. Check sensor and wiring. This alert clears automatically.

**Alert A168 - SPACE RELATIVE HUMIDITY OPEN SENSOR**

This alert occurs when the SPRH input is 0 mA and the sensor is configured as installed. Check sensor and wiring. This alert clears automatically.

**Alert A169 - SPACE HUMIDITY SHORTED SENSOR**

This alert occurs when the SPRH input is shorted and the sensor is configured as installed. Check sensor and wiring. This alert clears automatically.

**Alert A170 – ECON FEEDBACK RANGE**

This alert occurs when the Economizer analog feedback signal is outside the range of 1.3vdc to 10.3vdc and the feedback is configured to use. A short is 10.5vdc and an open circuit is less than 0.1vdc. Economizer diagnostics operation will be disabled. This is usually caused by a wiring problem, actuator failure, or the wrong actuator. Investigate using the Low Voltage Schematic; make sure the feedback signal from the actuator is correct. This alert clears automatically.

### **Alert A171 – ECON FEEDBACK OPEN**

See Alert A170

### **Alert A172 – ECON FEEDBACK SHORTED**

See Alert A170

### **Alert A190 – TSTAT HEAT/COOL CALLS**

This alert occurs in Thermostat mode when Y1 or Y2 is energized simultaneously with W1 or W2. Verify thermostat and thermostat wiring. The software will enter either the cooling or heating mode depending upon which input turned on first. This alert resets automatically when Y1 and Y2 are not on simultaneously with W1 and W2.

### **Alert A191 – TSTAT IMPROPER COOL**

This alert occurs in Thermostat mode when Y2 or Y3 is energized and Y1 is not. Verify thermostat and thermostat wiring. When this occurs the control will treat the inputs as a number instead of specific input. Example a Y2 and Y3 would mean 2 cooling inputs so the control would treat that as a Y1 and Y2 was active. This alert resets automatically when Y1 is turned On.

### **Alert A192 – TSTAT IMPROPER HEAT**

This alert occurs in Thermostat mode when W2 is energized and W1 is not. Verify thermostat and thermostat wiring. When W2 turns On, the software will behave as if W1 and W2 are both On. When W2 turns Off, the software will behave as if W1 and W2 are both Off. This alert resets automatically when W1 is turned On.

### **Fault F200 – FIRE SHUTDOWN**

This fault occurs when the fire shutdown input is either open or closed depending upon its configuration. This fault is usually caused by an auxiliary device that is trying to shut down the unit, e.g., smoke detector. This will cause a unit shutdown condition. Verify that the configuration is set correct, verify the wiring and auxiliary device. This fault resets automatically.

### **Fault F202 – FREEZE PROTECTION**

This fault occurs when the SAT falls below the minimum SAT setting (*UNIT'S MIN SAT*) for 30 seconds. The control will enter the safety shutdown condition. This fault will automatically reset if allowed (*AUTO SAT FAULTS? = YES*) and the SAT rises above the minimum SAT (*UNIT'S MIN SAT*) plus 15. The cause of this fault is usually excessive cold outdoor air, low air flow, or low charge.

### **Fault F201 – CONDENSATE OVERFLOW**

This fault occurs when the COFS input is either open or closed depending upon its configuration. This fault is usually caused by water reaching a high level in the drain pan. This will cause a cooling lockout. Verify that the configuration is set correct, verify the wiring and auxiliary device. This fault resets automatically.

### **Alert A203 – DIRTY FILTER**

This alert occurs when the Filter Status switch senses a plugged filter for 5 continuous seconds after the indoor fan has been running for 10 seconds or if the fan has run for longer than the change filter time. Because the Dirty Air Filter switch can be configured normally opened or closed, the switch might be open or closed. Verify that the configurations are set correct, verify the wiring and filter status switch. The hose should be connected to the low side of the switch. The alert resets automatically if it was tripped due to the filter switch. If the alert is tripped because of the timer, it will need to be reset after the filter has been replaced or inspected. Rest the time with the *RESET FILTER TIME* point is located under *RUN STATUS → GENERAL* or *INPUTS → GENERAL INPUTS*.

### **Fault F204 – REMOTE SHUTDOWN**

This fault occurs when the remote shutdown input is either open or closed depending upon its configuration and configured to set a fault. This fault is usually caused by an auxiliary emergency device that is trying to shut down the unit. This will cause a unit shutdown condition. Verify that the configuration

is set correct, verify the wiring and auxiliary device. This fault resets automatically.

### **Fault F205 – IDF MANUAL LIMIT TRIP**

This fault occurs when the indoor fan limit switch input is lost. The switch is a manual reset limit that is normally closed. This fault is usually caused by excess heat seen at the indoor fan. This fault will cause a unit shutdown condition. Since the switch is manual reset the button on the switch will have to be reset before resetting this fault in the software.

### **Fault F206 – PHASE MONITOR TRIP**

This fault occurs when the phase monitor input is either open or closed depending upon its configuration. This fault is usually caused by loss of phase or improper phasing of a 3 phase power supply. This will cause a unit shutdown condition. Verify that the configuration is set correct, verify the wiring and supply power. This fault resets automatically.

### **Alert A210 – GENERAL STATUS**

This alert occurs when the general status input is either open or closed depending upon its configuration and configured to set a alert. This alert is usually caused by an auxiliary switch device that is trying to send a warning about the unit. Verify that the configuration is set correct, verify the wiring and auxiliary device. This alert resets automatically.

### **Fault F211 – GENERAL STATUS**

This fault occurs when the general status input is either open or closed depending upon its configuration and configured to set a fault. This fault is usually caused by an auxiliary switch device that is trying to shut down the unit. This will cause a unit shutdown condition. Verify that the configuration is set correct, verify the wiring and auxiliary device. This fault resets automatically.

### **Fault F310 – CIRA DOWN DUE TO FAIL**

This fault occurs when both compressors on circuit A have 3 strikes. Investigate the alerts that caused the strikes to occur, and correct or test as needed. Manual alarm reset or power cycle is required to rest this fault.

### **Fault F311 – CIRA LOW CHARGE**

This alert occurs when the compressors are off and both the discharge and suction pressure are less than the low charge level (*LOW CHARGE LEVEL*) and OAT is greater than the low charge limit (*NO LOW CHARGE OAT*). The cause of the alert is usually low refrigerant pressure or faulty pressure transducers. This alert only occurs when the compressor is OFF because the low refrigerant pressure alert will handle this situation when the compressor is operating. Manual alarm reset or power cycle is required to rest this fault.

### **Alert A312 – CIRA UNEXPECTED OFF**

These alerts occur when the suction pressure raises the configured amount and the pressure ratio drop the configured amount both in a 10 second window during compressor operation. When this occurs, the control turns off the compressors and logs a strike for which compressor that was on. This alerts reset automatically. The possible causes are: high-pressure switch (HPS) open (the HPS is wired in series with compressor relays on the MBB), compressor internal protection is open, or a wiring error (a wiring error might not allow the compressor to start). This alert can be enabled and disabled under menu *SETTINGS → UNIT CONFIGURATION → COMPRESSOR DIAG → COMPRESSOR TRANSITION → DIAG. COMP OFF*.

During mechanical heat while transitioning in and out of defrost mode, this unexpected off alert will wait an additional time (*DEFROST UEOFF DLY*) before tripping to ensure proper transition.

### **Alert A313 – CIRA HIGH DISCHARGE**

This alert occurs when the discharge pressure is greater than the configured *CIRA SDP LIMIT* amount. This alert resets

automatically when the pressure falls 20 psig below the threshold. When running both compressors the control will remove A1 and add a strike to it. The control will also set the ODFs to the high cool speed. The cause of the alert is usually an overcharged system, high outdoor ambient temperature coupled with dirty outdoor coil, plugged filter drier, or ODF airflow is too low.

#### **Alert A314 — CIR.A HPS TRIP**

This alert occurs when the discharge high pressure switch opens. This alert resets automatically when the pressure falls below the switch threshold and the switch closes for 3 minutes. The control will add a strike for which ever compressors were on. The control will also set the ODFs to the high cool speed. The cause of the alert is usually an overcharged system, high outdoor ambient temperature coupled with dirty outdoor coil, plugged filter drier, or ODF airflow is too low.

#### **Alert A315 — CIR.A LOW DISCHARGE**

This alert occurs when the discharge temperature is less than the OAT plus the configured **LOW DISCHARGE LEV** amount. This alert resets automatically. The control will add a strike for which ever compressors were on. The cause of the alert is usually an undercharged system, low outdoor ambient temperature coupled with dirty outdoor coil, plugged filter drier, or ODF airflow is too high. This alert can be enabled and disabled under menu **SETTINGS→UNIT CONFIGURATION→COMPRESSOR DIAG→CHARGE DIAGNOSTICS→LOW DISCHARGE DIAG.**

#### **Alert A316 — CIR.A LOW SUCTION**

This alert occurs when the compressor is operating and the evaporating temperature (converted from the suction pressure) is less than configured low suction control levels, **LOW SUC LEVEL 1**, **LOW SUC LEVEL 2**, or **LOW SUC LEVEL 3**. The circuit SST value must be less than **LOW SUC LEVEL 1** (for 5 minutes), **LOW SUC LEVEL 2** (for 4 minutes), or **LOW SUC LEVEL 3** (for 3 minutes when using the economizer and 1.5 minutes when not using the economizer) for the alert to occur. When the outdoor temperature is less than 40°F, the above values are reduced 1°F for every 2°F OAT is below 40°F. All the above timers will reset if the suction temperature rises above **LOW SUC OK TEMP** for 1 minute. This alert causes a strike for the respective circuit. This alert will activate when the coil becomes frosted. However, during the 15-minute reset period, the coils will thaw and strike should clear and restart if there is nothing else wrong with the circuit. The alert resets automatically. The cause of the alert is usually low refrigerant charge, dirty filters, evaporator fan operating backwards, loose or broken belt, plugged filter drier, faulty transducer, excessively cold return air, or stuck open economizer when the ambient temperature is low.

During mechanical heating there is an additional offset to shift the levels to account for heating lower suctions. The offset (**HEAT LO SUC OFFST**) is defaulted to 30°F to prevent most suction nuisances and should not need to be changed.

#### **Alert A317 — CIR.A PRESSURE RATIO**

This alert occurs when the Circuit A pressure ratio is less than the configured **MIN PRESSURE RATIO** amount. This alert resets automatically. The control will add a strike for which ever compressors were on. The cause of the alert is usually an undercharged system, low outdoor ambient temperature coupled with dirty outdoor coil, plugged filter drier, or ODF airflow is too high.

#### **Fault F318 – COMPRESSOR STUCK ON**

This alert occurs when the Suction pressure does not raise the minimum suction amount (**CIR.A MIN SUC.P**) and the ratio did not fall at least the off pressure ratio (**OFF P.RATIO**). When this occurs, the control turns off all of the compressors, and enters a safety shutdown condition. The possible causes are a welded contactor or frozen compressor relay on MBB. Manual alarm reset or

power cycle is required to rest this fault. This alert can be enabled and disabled under menu **SETTINGS→UNIT CONFIGURATION→COMPRESSOR DIAG→COMPRESSOR TRANSITION→CIR STUCK ON DIAG.**

#### **Fault F319 – C.A1 DOWN DUE TOFAIL**

This fault occurs when compressor A1 has 3 strikes. Investigate the alerts that caused the strikes to occur, and correct or test as needed. Manual alarm reset or power cycle is required to rest this fault.

#### **Alert A320 – C.A1 REVERSE ROTATION**

This alert occurs when 10 seconds after the compressor turns on, the suction rose and the discharge pressure dropped. This alert causes a strike for the compressor. The alert resets automatically. The cause of the alert is usually compressor wiring causing reverse rotation or a faulty compressor.

#### **Alert A321 – C.A1 FAIL TO PRESSURE**

This alert occurs when 10 seconds after the compressor turns on, the suction did not drop more than suction amount (**CIR.A MIN SUC.P**) and discharge pressure did not rise more than discharge amount (**CIR.A MIN DIS.P**). This alert causes a strike for the compressor. The alert resets automatically. The cause of the alert is usually compressor wiring causing reverse rotation or a faulty compressor.

#### **Fault F412 – RUN AWAY HEAT**

This fault occurs when the SAT rises above the maximum SAT (**UNIT'S MAX SAT**). The control will enter the safety shutdown condition. This fault will automatically reset if allowed (**AUTO SAT FAULTS? = YES**) and the SAT falls below the maximum SAT (**UNIT'S MAX SAT**) minus 50. The cause of this alert is usually heat stuck on causing high SAT, or low air flow.

#### **Alert A510 – INDOOR FAN STATUS**

This alert occurs when a fan status switch is installed, the unit is configured not to shut down on fan status, and the fan status switch does not match the state of the fan. The cause of this is usually a configuration error on the switch state in the software or the setting on the actual switch itself.

#### **Fault F511 – IDF OFF WHEN COMMAND ON**

This fault occurs when the unit is configured to shut down on fan status and the fan is requested greater than zero and the fan status switch indicates the fan is off. The cause of this alert is usually a configuration error on the switch state in the software or the setting on the actual switch itself. Manual alarm reset or power cycle is required to reset this fault.

#### **Fault F512 – IDF ON WHEN COMMAND OFF**

This fault occurs when the unit is configured to shut down on fan status and the fan is requested off and the fan status switch indicates the fan is off. The cause of this alert is usually a configuration error on the switch state in the software or the setting on the actual switch itself. Manual alarm reset or power cycle is required to reset this fault.

#### **Alert A700 – ECON NOT MODULATING**

This alert occurs when the economizer feedback is enabled and the actual speed does not reach the commanded speed in the economizer travel time configuration value. This alert will automatically reset when the actual position does reach the commanded position. This is usually caused by installation of the wrong actuator, no economizer gear motion, or actuator direction control switch (CCW, CW) wrong. Check damper blades, gears, and actuator. This alert will usually be accompanied by another descriptive informational alert.

#### **Alert A701 – ECON STUCK CLOSED**

This alert occurs when damper not modulating alert is active and actual damper position is zero. This alert will be reset once the damper not modulating alert becomes inactive. This alert will also be reset upon resetting all current alarm commands.

### Alert A702 – ECON STUCK OPEN

This alert occurs when damper not modulating alert is active, commanded damper position is zero and actual damper position is greater than two. This alert will be reset once the damper not modulating alert becomes inactive. This alert will also be reset upon resetting all current alarm commands.

### Alert A703 – IDF MECH DISCONNECTED

This alert occurs when Alert A700 is not active yet the control determines that the economizer changes are not aligning with the temperature changes. This will require a manual reset to ensure the economizer is inspected. This is usually caused by the actuator not properly secured to the damper shaft.

### Alert A710 – ECON NOT COOLING

This alert occurs when freecooling is active, damper modulation alert is active and the actual damper position is less than

the requested damper position by two. This alert will be reset once the damper not modulating alert becomes inactive and it is also reset when all the current alarm commands are reset.

### Alert A711 – ECON IMPROPER COOLING

This alert occurs when freecooling is inactive, damper modulation alert is active and the actual damper position is greater than minimum position. This alert will be reset once the damper not modulating alert becomes inactive and it is also reset when all the current alarm commands are reset.

### Alert A712 – EXCESSIVE OUTDOOR AIR

This alert occurs when freecooling is inactive, damper modulation alert is active and the actual damper position is greater than minimum position. This alert will be reset once the damper not modulating alert becomes inactive and it is also reset when all the current alarm commands are reset.

**Table 14 — SystemVu Controller Alarm Codes**

FAULT OR ALERT	ACTION TAKEN BY CONTROL	RESET METHOD	PROBABLE CAUSE
F010-MBB LOW VOLTAGE	Unit Shutdown	Automatic	Brownout condition, low supply voltage, supply power missing a phase.
F011-MBB REFERENCE VOLTAGE	Unit Shutdown	Automatic	MBB failure or supply voltage low
A012-MBB ZERO CROSSING	Alert Generated	Automatic	MBB failure or supply voltage frequency to high or too low.
F013-MBB FUSE 2 OPEN	Unit Shutdown	Automatic	A switch input has a wiring error or the switch pulled too much current.
F014-MBB FUSE 3 OPEN	Unit Shutdown	Automatic	A switch input has a wiring error or the switch pulled too much current.
A015-MBB RNET VOLTAGE RANGE	Alert Generated	Automatic	MBB failure or supply voltage low
A016-MBB 24VDC RANGE	4-20mA inputs will be in error	Automatic	MBB failure or supply voltage low
A017-MBB 5VDC RANGE	Transducer inputs will be in error	Automatic	MBB failure or supply voltage low
F018-MBB EEPROM FAILURE	Unit Shutdown	Automatic	Software failure or MBB failure
A019-MBB CLOCK FAILURE	No time, date, and schedule operation	Automatic	Software failure or MBB failure
F020-SOFTWARE ERROR	Unit Shutdown	Automatic	Corrupt Software or software failure
A100-SAT SENSOR ERROR	No free cooling, and no SAT limit protection	Automatic	Faulty, shorted, or open thermistor caused by wiring error or loose connection.
A101-FST SENSOR RANGE	Alert Generated	Automatic	Faulty or incorrect thermistor caused by improper ohm reading
A102-FST OPEN SENSOR	Alert Generated	Automatic	Missing or open thermistor caused by wiring error or loose connection.
A103-FST SHORTED SENSOR	Alert Generated	Automatic	Faulty or shorted thermistor caused by wiring error or loose connection.
A104-OAT SENSOR RANGE	No free cooling, no low ambient operation	Automatic	Faulty or incorrect thermistor caused by improper ohm reading
A105-OAT OPEN SENSOR	No free cooling, no low ambient operation	Automatic	Missing or open thermistor caused by wiring error or loose connection.
A106-OAT SHORTED SENSOR	No free cooling, no low ambient operation	Automatic	Faulty or shorted thermistor caused by wiring error or loose connection.
A107-RAT SENSOR RANGE	No differential DB crossover	Automatic	Faulty or incorrect thermistor caused by improper ohm reading
A108-RAT OPEN SENSOR	No differential DB crossover	Automatic	Missing or open thermistor caused by wiring error or loose connection.
A109-RAT SHORTED SENSOR	No differential DB crossover	Automatic	Faulty or shorted thermistor caused by wiring error or loose connection.
A110-SPT SENSOR RANGE	No heating or cooling	Automatic	Faulty or incorrect thermistor caused by improper ohm reading
A111-SPT OPEN SENSOR	No heating or cooling	Automatic	Missing or open thermistor caused by wiring error or loose connection.
A112-SPT SHORTED SENSOR	No heating or cooling	Automatic	Faulty or shorted thermistor caused by wiring error or loose connection.
A130-CIR.A SSP SENSOR RANGE	Shutdown Circuit A	Automatic	Faulty transducer, faulty 5-V power supply, or loose connection
A131-CIR.A SSP OPEN SENSOR	Shutdown Circuit A	Automatic	Faulty transducer, faulty 5-V power supply, or loose connection
A132-CIR.A SSP SHORT SENSOR	Shutdown Circuit A	Automatic	Faulty transducer, faulty 5-V power supply, or loose connection
A133-CIR.A SDP SENSOR RANGE	Shutdown Circuit A	Automatic	Faulty transducer, faulty 5-V power supply, or loose connection
A134-CIR.A SDP OPEN SENSOR	Shutdown Circuit A	Automatic	Faulty transducer, faulty 5-V power supply, or loose connection
A135-CIR.A SDP SHORT SENSOR	Shutdown Circuit A	Automatic	Faulty transducer, faulty 5-V power supply, or loose connection
A150-OUTDOOR AIRFLOW IN CFM OPEN SENSOR	No OACFM Operations	Automatic	Wiring problem, or configuration error
A151-OUTDOOR AIRFLOW IN CFM SHORTED SENSOR	No OACFM Operations	Automatic	Wiring problem, or configuration error
A160-OARH OPEN SENSOR	No Enthalpy crossover	Automatic	Bad sensor, bad wiring, or sensor configured incorrectly.
A161-OARH SHORTED SENSOR	No Enthalpy crossover	Automatic	Bad sensor, bad wiring, or sensor configured incorrectly.
A162-RARH OPEN SENSOR	No Differential Enthalpy crossover	Automatic	Bad sensor, bad wiring, or sensor configured incorrectly.
A163-RARH SHORTED SENSOR	No Differential Enthalpy crossover	Automatic	Bad sensor, bad wiring, or sensor configured incorrectly.
A164- IAQ OPEN SENSOR	No IAQ Operations	Automatic	Bad sensor, bad wiring, or sensor configured incorrectly.
A165- IAQ SHORTED SENSOR	No IAQ Operations	Automatic	Bad sensor, bad wiring, or sensor configured incorrectly.
A166-OAQ OPEN SENSOR	No OAQ Operations	Automatic	Bad sensor, bad wiring, or sensor configured incorrectly.
A167-OAQ SHORTED SENSOR	No OAQ Operations	Automatic	Bad sensor, bad wiring, or sensor configured incorrectly.
A168-SPACE RELATIVE HUMIDITY OPEN SENSOR	No dehumidifying	Automatic	Bad sensor, bad wiring, sensor configured incorrectly, loss of communication to SIOB.
A169-SPACE RELATIVE HUMIDITY SHORTED SENSOR	No dehumidifying	Automatic	Bad sensor, bad wiring, sensor configured incorrectly, loss of communication to SIOB.
A170-ECON FEEDBACK RANGE	No economizer diagnostics	Automatic	Wiring problem with actuator, or configuration error

**Table 14 — SystemVu Controller Alarm Codes (cont)**

FAULT OR ALERT	ACTION TAKEN BY CONTROL	RESET METHOD	PROBABLE CAUSE
A171-ECON FEEDBACK OPEN	No economizer diagnostics	Automatic	Wiring problem with actuator, or configuration error
A172-ECON FEEDBACK SHORTED	No economizer diagnostics	Automatic	Wiring problem with actuator, or configuration error
A190-TSTAT HEAT/COOL CALLS	Run unit in mode activated first	Automatic	Bad Thermostat or Thermostat Wiring
A191-TSTAT IMPROPER COOL	Run cooling per number of active inputs	Automatic	Bad Thermostat or Thermostat Wiring
A192-TSTAT IMPROPER HEAT	Run heating per number of active inputs	Automatic	Bad Thermostat or Thermostat Wiring
F200-FIRE SHUTDOWN	Unit Shutdown	Automatic	Smoke detected by smoke detector
F201-CONDENSATE OVERFLOW	Cooling Shutdown	Automatic	Drain pan plugged, sensor error, or configuration error
F202 - FREEZE PROTECTION	Unit Shutdown	Automatic	SAT is too low, caused by cold outdoor air, low air flow, or stuck on cooling.
A203-DIRTY FILTER	Alert Generated	Automatic	Dirty Filter or filter timer expired
F204-REMOTE SHUTDOWN	Unit Shutdown	Automatic	Remote activation of the shutdown switch
F205- IDF MANUAL LIMIT TRIP	Unit Shutdown	Automatic	Limit Switch on Indoor Fan trips due to high temperature at the motor
F206-PHASE MONITOR TRIP	Unit Shutdown	Automatic	Power supply phase missing or out of phase
A210-GENERAL STATUS	Alert Generated	Automatic	General Switch activation or wrong configuration
F211-GENERAL STATUS	Unit Shutdown	Automatic	General Switch activation or wrong configuration
F310-CIRA DOWN DUE TO FAIL	Shutdown Circuit A	Manual	Compressors have 3 strikes or has been locked out by another alarm
F311-CIRA LOW CHARGE	Shutdown Circuit A	Manual	Low refrigerant or faulty pressure transducer
A312-CIR.A UNEXPECTED OFF	Strike for active compressors	Automatic	Compressor failure, transducer failure, or nuisance operating conditions
A313-CIR.A HIGH DISCHARGE	Unload compression and up ODF to High cool speed	Automatic	An overcharged system, high outdoor ambient temperature coupled with dirty outdoor coil, plugged filter drier, or ODF too low.
A314-CIR.A HPS TRIP	Add compressor strikes	Automatic	An overcharged system, high outdoor ambient temperature coupled with dirty outdoor coil, plugged filter drier, or ODF too low.
A315-CIR.A LOW DISCHARGE	Add compressor strikes	Automatic	An undercharged system, low outdoor ambient temperature coupled with dirty outdoor coil, plugged filter drier, or ODF too high
A316- CIR.A LOW SUCTION	Add compressor strikes	Automatic	Low refrigerant charge, dirty filters, evaporator fan turning backwards, loose or broken fan belt, plugged filter drier, faulty transducer, excessively cold return air, or stuck open economizer when the ambient temperature is low.
A317-CIR.A PRESSURE RATIO	Add compressor strikes	Automatic	Low refrigerant charge, plugged filter drier, faulty transducer, the ambient temperature is low and the ODF is running too fast.
F318-COMPRESSOR STUCK ON	Unit in Safety Shutdown	Manual	Welded contactor or frozen compressor relay on MBB
F319-C.A1 DOWN DUE TO FAIL	Lockout Compressor A1	Manual	Compressor A1 has 3 strikes or has been locked out by another alarm
A320-C.A1 REVERSE ROTATION	Add Strike for compressor A1	Automatic	Wiring causing reverse rotation or faulty compressor
A321-C.A1 FAIL TO PRESSURE	Add Strike for compressor A1	Automatic	Wiring causing reverse rotation or faulty compressor
F412-RUN AWAY HEAT	Unit in Safety Shutdown	Automatic	Heat stuck on causing high SAT, or low air flow
A510- INDOOR FAN STATUS	Alert Generated	Automatic	Motor failure, or configuration error.
F511- IDF OFF WHEN COMMAND ON	Unit Shutdown	Manual	Fan stuck on, or Configuration incorrect.
F512-IDF ON WHEN COMMAND OFF	Unit Shutdown	Manual	Tripped Circuit Breaker. Bad indoor fan motor. Configuration incorrect.
A700-ECON NOT MODULATING	Alert Generated	Automatic	No economizer motion. Check damper blades, gears, and actuator. Actuator direction control switch (CCW, CW) wrong.
A701-ECON STUCK CLOSED	Alert Generated	Automatic	No economizer motion. Check damper blades, gears, and actuator. Actuator direction control switch (CCW, CW) wrong.
A702-ECON STUCK OPEN	Alert Generated	Automatic	No economizer motion. Check damper blades, gears, and actuator. Actuator direction control switch (CCW, CW) wrong.
A703-ECON MECH DISCONNECTED	Alert Generated	Manual	No economizer motion. Check damper blades, gears, and actuator. Actuator direction control switch (CCW, CW) wrong.
A710-ECON NOT COOLING	Alert Generated	Automatic	No economizer motion. Check damper blades, gears, and actuator. Actuator direction control switch (CCW, CW) wrong.
A711-ECON IMPROPER COOLING	Alert Generated	Automatic	No economizer motion. Check damper blades, gears, and actuator. Actuator direction control switch (CCW, CW) wrong.
A712-EXCESSIVE OUTDOOR AIR	Alert Generated	Automatic	No economizer motion. Check damper blades, gears, and actuator. Actuator direction control switch (CCW, CW) wrong.

**Control Module Communication**

**RED LED**

Proper operation of the MBB control board can be visually checked by looking at the red status LED. When operating correctly, the red status LED should blink at a rate of once every 2 seconds. If the red LED is not blinking, verify that correct power is being supplied. A blinking red LED at the rate of once per second means that software is not loaded on the board. Also, be sure that the board is supplied with the current software. If necessary, reload current software. A board LED that is lit continuously should be replaced.

**GREEN LED**

The MBB has one green LED. The Local Equipment Network (LEN) LED should always be blinking whenever power is on. If

LEN LED is not blinking, check LEN connections for potential communication errors (MBB J15, J16, J17, and on the Display J2). Communication between modules is accomplished by a 3-wire sensor bus. These 3 wires run in parallel from module to module. The MBB J17 and Display J2 connectors provide both power and communication directly at the connector for accessories like the Navigator display. The MBB J15 connector provides a LEN interface to the indoor fan VFD.

**YELLOW LED**

The MBB has one yellow LED which is used to indicate Building Automated System (BAS) communication activity. The LED will blink when the MBB transmits a message on the bus.

**Communication Failures**

If the Navigator displays Communication Failure or the green or yellow LEDs do not flash on the boards then the problem could



be the communication chip on one of the control boards (MBB). Use an ohm meter to measure the resistance on the communication pins of the boards to determine if the board is bad. If the reading is less than half the value indicated in Table 15, then the board needs to be replaced.

**IMPORTANT:** The resistive values should be read when the board is powered off, the unit is locked out, and board connectors are disconnected.

### Cooling Troubleshooting

Use the SystemVu Display or a CCN device to view the cooling status display and the cooling diagnostic display (see Appendices) for information on the cooling operation. Check the current alarms and alarm history for any cooling alarm codes and correct any causes. (See Table 14.) Verify any unique control configurations per installed site requirements or accessories.

If alarms conditions are corrected and cleared, operation of the compressors and fans may be verified by using the Service Test mode. (See Table 4.) See Table 16 for general cooling service analysis.

**Table 15 — Communication Resistances**

Device	(LEN) Resistance between Pins / Connector			(BAS) Resistance between Pins / Connector			(RNET) Resistance between Pins / Connector		
	Pins 1 to 3	Pins 1 to 2	Pins 2 to 3	Pins 1 to 3	Pins 1 to 2	Pins 2 to 3	Pins GND to +	Pins GND to -	Pins + to -
<b>MBB</b>	19.92 KΩ	10.63 KΩ	9.51 KΩ	19.92 KΩ	10.63 KΩ	9.51 KΩ	2.25 KΩ	1 KΩ	3.3 KΩ

**Table 16 — Cooling Service Analysis**

PROBLEM	CAUSE	REMEDY
<b>Compressor and Fan Will Not Start.</b>	Power failure.	Call power company.
	Fuse blown or circuit breaker tripped.	Replace fuse or reset circuit breaker.
	Disconnect off.	Power disconnect.
	Compressor time guard to prevent short cycling.	Check using SystemVu Display.
	Thermostat or occupancy schedule set point not calling for Cooling.	Check using SystemVu Display.
	Outdoor temperature too low.	Check Compressor Lockout Temperature using SystemVu Display.
	Active alarm.	Check active alarms using SystemVu Scrolling Marquee.
<b>Compressor Cycles (other than normally satisfying thermostat).</b>	Insufficient line voltage.	Determine cause and correct.
	Active alarm.	Check active alarms using SystemVu Scrolling Marquee.
<b>Compressor Operates Continuously.</b>	Unit undersized for load.	Decrease load or increase size of unit.
	Thermostat or occupancy schedule set point too low.	Reset thermostat or schedule set point.
	Dirty air filters.	Replace filters.
	Low refrigerant charge.	Check pressure, locate leak, repair, evacuate, and recharge.
	Condenser coil dirty or restricted.	Clean coil or remove restriction.
<b>Excessive Condenser Pressures.</b>	Dirty condenser coil.	Clean coil.
	Refrigerant overcharge.	Recover excess refrigerant.
	Faulty TXV.	1. Check TXV bulb mounting and secure tightly to suction line and insulate. 2. Replace TXV (and filter drier) if stuck open or closed.
	Condenser air restricted or air short cycling.	Determine cause and correct.
	Restriction in liquid tube.	Remove restriction.
<b>Condenser Fans Not Operating.</b>	No Power to contactors.	Fuse blown or plug at motor loose.
<b>Excessive Suction Pressure.</b>	High heat load.	Check for sources and eliminate
	Faulty TXV.	1. Check TXV bulb mounting and secure tightly to suction line and insulate. 2. Replace TXV (and filter drier) if stuck open or closed.
	Refrigerant overcharged.	Recover excess refrigerant.
<b>Suction Pressure Too Low.</b>	Dirty air filters.	Replace air filters.
	Low refrigerant charge.	Check pressure, locate leak, repair, evacuate, and recharge.
	Faulty TXV.	1. Check TXV bulb mounting and secure tightly to suction line and insulate. 2. Replace TXV (and filter drier) if stuck open or closed.
	Insufficient evaporator airflow.	Check belt tension. Check for other restrictions.
	Temperature too low in conditioned area (low return-air temperature).	Reset thermostat or occupancy schedule.

**LEGEND**

**TXV** — Thermostatic Expansion Valve

## Economizer Troubleshooting

Use the SystemVu Display to view the economizer status. Check the current alerts and faults and the alarm history for economizer specific alerts or any relevant faults or alerts and correct those issues. Use test mode to troubleshoot by ramping the economizer up and down with and without the indoor fan and power exhaust fan on. Inspect the mechanical economizer for actuator, gear, or blade damage. Ensure the actuator is mounted with the correct spring return (close damper when no power applied to unit). Ensure there is a 500 ohm resistor across the actuator as the 4-20mA output signal must be converted to 2-10V.

Feedback from the actuator is a 2 to 10 volt feedback. If the feedback does not reach 2 volts when commanded to 0% a negative trim (**ECO FEEDBACK TRIM** in the Service Calibration menu) can be put on the feedback to stop economizer alarms occurring at 0%. If this done the max damper position (**ECON MAX POS** in the Economizer Settings menu) must be set less than 100% to prevent Economizer alarms at 100% since the trimmed value will not reach 100% at 10 Volts. Both signals can be measured with a meter on the signal and feedback wires J7 pins 4 and 3 respectively and referenced to ground J7 pin 8 while the values can be displayed on the local display.

The economizer alerts can be summarized as a failure to modulate the damper blades. This can be due to the actuator not being properly connected to the damper, or because the actuator's feedback signal is indicating that damper is not performing as commanded. The mechanical disconnect diagnostic will run when conditions are appropriate to determine proper air temperature

changes. This uses the OAT, RAT, and SAT to tell if the damper is mixing the outdoor air with the return air. The other alerts inform where the damper is stuck relative to the commanded position.

See Table 17 for further information on economizer troubleshooting.

### ECONOMIZER CALIBRATION

For best accuracy of the damper actuator or if nuisance 700 alarms occur, a damper calibration should be performed. The damper calibration will drive the damper open then closed to find max and minimum values and correct its range of motion limits. The correction factors can be viewed after the calibration is done under the **SERVICE → CALIBRATION → ECON DAMPER CAL** menu.

To initiate an economizer calibration put the unit in test mode then turn on the Calibrate Damper (**SERVICE TEST → INDEPENDENTS → CALIBRATE DAMPER**). To ensure best performance, it is recommended that you readjust the actuator to the damper assembly. First power off unit (spring return the damper), loosen the actuator clamp, while pushing the outside air damper closed, tighten the clamp, and then perform the calibration. The calibration can take up to 5 minutes to complete and will inform you when completed. If any alerts were active for activated during the calibration, wait a few minutes to see if they go away. If not, using test mode open then close the damper to clear them, or reset alarms.

**Table 17 — Economizer Service Analysis**

PROBLEM	POSSIBLE CAUSE	REMEDY
<b>Damper Does Not Move.</b>	Indoor Fan is off.	Check for proper thermostat connection.
		Unit is not configured for continuous fan operation and the thermostat is not calling for heating or cooling.
		Unit is in Unoccupied mode and there is no call for heating or cooling.
		Tripped circuit breaker.
		No power to the unit.
	Unit is off via CCN command.	
	Actuator is unplugged at motor or at economizer board.	Check wiring connections.
Unit is not configured for economizer.	Configure unit for economizer per the instructions.	
Outdoor-air temperature is above economizer high temperature lockout.	Adjust the high temperature lockout setting if it is incorrect, otherwise, economizer is operating correctly.	
Outdoor-air temperature is below economizer low temperature lockout.	Adjust the low temperature lockout setting if it is incorrect, otherwise, economizer is operating correctly.	
Communication loss to economizer board.	Check wiring connections.	
Damper is jammed.	Identify the obstruction and safely remove.	
<b>Economizer Operation is Limited to Minimum Position.</b>	Minimum position is set incorrectly.	Adjust minimum position setting.
	Outdoor-air temperature is above economizer high temperature lockout.	Adjust the high temperature lockout setting if it is incorrect, otherwise, economizer is operating correctly.
	Outdoor-air temperature is below economizer low temperature lockout.	Adjust the low temperature lockout setting if it is incorrect, otherwise, economizer is operating correctly.
	Enthalpy or differential dry bulb are preventing free cooling.	Check enthalpy and return air compared to outside air temperature.
	Outdoor-air thermistor is faulty.	Replace outdoor-air thermistor.
	Low suction pressure problem with a compressor.	Economizer is operating correctly, identify compressor problem.
<b>Economizer Position is Less Than Minimum Position.</b>	IAQ is controlling minimum damper position.	Adjust the IAQ settings if incorrect, otherwise, the economizer is operating correctly.
	Unit is in Unoccupied mode.	Adjust unit occupied schedule if incorrect, otherwise, economizer is operating correctly.
<b>Economizer Does Not Return to Minimum Position.</b>	Unit is operating under free cooling.	Economizer is operating correctly.

**Table 17 — Economizer Service Analysis (cont)**

PROBLEM	POSSIBLE CAUSE	REMEDY
Damper Does Not Close on Power Loss.	Damper is jammed or spring return is backwards.	Identify the obstruction and safely remove.
Economizer is Not at Configured Minimum Position	Unit is operating under free cooling or a force is applied to the commanded position.	Economizer is operating correctly.

LEGEND

- CCN — Carrier Comfort Network
- IAQ — Indoor Air Quality

**Heating Troubleshooting**

Use the unit SystemVu Display or a CCN device to view the heating status display and the heating diagnostic display (see Appendices) for information on the heating operation. Check the current alarms and alarm history for any heating alarm codes and correct any causes. (See Table 14.) Verify any unique control configurations per installed site requirements or accessories. If alarms conditions are corrected and cleared,

operation of the heat stages and indoor fan may be verified by using the Service Test mode. (See Table 4.)

**ELECTRIC HEAT**

See Table 18 for electric heating service analysis.

**Table 18 — Electric Heat Service Analysis**

PROBLEM	CAUSE	REMEDY
<b>Heat Will Not Turn On.</b>	Active alarm.	Check active alarms using SystemVu™ Display.
	Unit is NOT configured for heat.	Check heating configurations using the SystemVu Display
	No power to unit.	Check power supply, fuses, wiring, and circuit breakers.
	Unit is in minimum heat off-time, or minimum cool-heat changeover time.	Check using SystemVu Display.
	Thermostat or occupancy schedule setpoint not calling for heating.	Check using SystemVu Display.
	Heat forced off in Service Test mode.	Check using SystemVu Display. Turn Service Test mode off.
	No 24 VAC at heater contactor.	Check transformer and circuit breaker.
		Check auto-reset limit switches on heater.
Check manual-reset limit switch (LS) on indoor fan housing.		
Open temperature limit switch on heater.	Check minimum airflow. Check limit switch when it is cool, replace if open.	
<b>Inadequate Heating.</b>	Dirty air filters.	Replace air filters.
	Thermostat or occupancy schedule setpoint only calling for W1.	Allow time for W2 to energize or adjust setpoints.
	Heat undersized for load.	Decrease load or increase size of heater.
	Restricted airflow	Remove restriction. Check SAT compared to the SAT heating limits.
	Too much outdoor air.	Check economizer position and configuration. Adjust minimum position.
	Limit switch cycles heaters.	Check rotation of blower and minimum airflow.
	Bad heater elements.	Power off unit and remove high voltage wires. Check resistance of element, replace if open.
<b>Heat Will Not Turn Off.</b>	Unit is in minimum heat on-time.	Check using SystemVu Display.
	Thermostat or occupancy schedule setpoint still calling for heating.	Check using SystemVu Display.
	Heat forced on in Service Test mode.	Check using SystemVu Display. Turn Service Test mode off.
	Heater contactor failed.	Power off unit. Check contactor and replace if closed.

## Phase Protection

The phase loss protection option will monitor the three-phase electrical system to provide phase reversal and phase loss protection.

### PHASE REVERSAL PROTECTION

If the control senses an incorrect phase relationship, the relay (K1) will be de-energized (opening its contact). If the phase relationship is correct, the relay will be energized. The control has a self-bypass function after a pre-set time. If the control determines that the three phases stay in a correct relationship for 10 consecutive minutes, the relay will stay energized regardless of the phase sequence of three inputs as long as 24-VAC control voltage is applied. This self-bypass function will be reset if all three phases are restored in a phase loss event.

### PHASE LOSS PROTECTION

If the reverse rotation board senses any one of the three phase inputs has no AC voltage, the relay will be de-energized (opening its contact). This protection is always active as long as 24-VAC control voltage is applied, and is not affected by the self by-pass function of the phase sequence monitoring function. However, in the event of phase loss, the relay will be re-energized only if all three phases are restored and the three phases are in the correct sequence.

A red LED is provided to indicate the function of the board. See the table below.

LED STATUS	FUNCTION
On Continuously	Relay contact closed (normal operation).
Blinking	Relay contact open (phase loss or phase reversal has occurred) — No power will be supplied to the control system.
Off	24-VAC control power not present (off).

## Thermistor Troubleshooting

The SystemVu controller uses thermistors to sense temperatures used to control operation of the unit. Resistances at various temperatures are listed in Table 19. Thermistor pin connection points are shown in the Major System Components section. The general locations of the thermistors are shown the Major System Components section.

### AIR TEMPERATURES

Air temperatures are measured with 10K thermistors. This includes supply-air temperature (SAT), outdoor-air temperature (OAT), space temperature sensors (T55, T56, T59), and return air temperature (RAT).

The supply air temperature (SAT) and outdoor air temperature (OAT) thermistors use a snap-mount to attach through the unit sheet metal panels. The snap-mount tabs must be flattened on the tip end of the sensor to release for removal from the panel. (See Fig. 12.) To reinstall, make sure the snap-mount tabs extend out.

### THERMISTOR/TEMPERATURE SENSOR CHECK

A digital volt-ohmmeter is required to perform this check.

Connect the digital volt-ohmmeter across the appropriate thermistor terminals at the J8 connector on the Main Base Board (see Major System Components section). Using the voltage reading obtained, read the sensor temperature from Table 19 (on page 37).

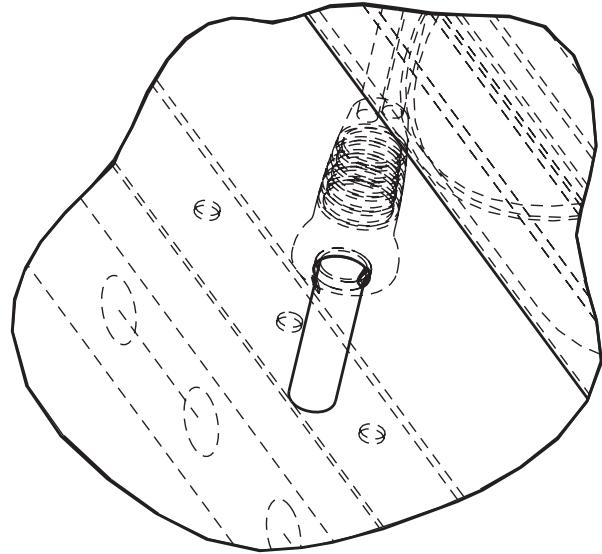


Fig. 12 — SAT and OAT Thermistor Mounting

To check thermistor accuracy, measure temperature at probe location with an accurate thermocouple-type temperature-measuring instrument. Insulate thermocouple to avoid ambient temperatures from influencing reading. Temperature measured by thermocouple and temperature determined from thermistor voltage reading should be close, within 5°F if care was taken in applying thermocouple and taking readings.

If a more accurate check is required, unit must be shut down and thermistor removed and checked at a known temperature (freezing point or boiling point of water) using either voltage drop measured across thermistor at the J8 connector, or by determining the resistance with unit shut down and thermistor disconnected from J8. Compare the values determined with the value read by the control in the Temperatures mode using the SystemVu display.

### Sensor Trim

Corrective offsets can be applied to all the analog inputs. Trim can be used as a form of calibration. The trim works by adding or subtracting the specified amount on the specified analog input. These corrections should only be use when a proper calibrated tool is used to compare to the sensors reading. These corrections are only applied to the local sensor values, a building systems (BAS) communicating values will not account for these corrections. Use the **SERVICE** → **CALIBRATION** menu on the SystemVu display to adjust these values.

### Transducer Troubleshooting

The electronic control uses suction and discharge pressure transducers to measure the pressure of the refrigerant circuits. The pressure/voltage characteristics of these transducers are in shown in Table 20 (on page 38) for suction transducers and Table 21 (on pages 39-41) for discharge transducers. The 5vdc power is applied to legs A and B of the transducer and legs B to C represent the signal voltage. To use the voltage drop table for troubleshooting, read the voltage across A and B, then subtract the voltage reading from B to C. The voltage drop can be looked up in Table 20 and Table 21 depending on the type of transducer. The accuracy of these transducers can be verified by connecting an accurate pressure gauge to the second refrigerant port in the suction and discharge lines.

**Table 19 — Temperature (°F) vs Resistance/Voltage Drop Values for OAT, RAT, SAT, and SPT Thermistors (10K at 25°C Type II Resistors)**

TEMP (F)	RESISTANCE (Ohms)	VOLTAGE DROP (V)	TEMP (F)	RESISTANCE (Ohms)	VOLTAGE DROP (V)	TEMP (F)	RESISTANCE (Ohms)	VOLTAGE DROP (V)
-25	196,453	4.758	41	25,396	3.587	107	4,984	1.663
-24	189,692	4.750	42	24,715	3.559	108	4,876	1.639
-23	183,300	4.741	43	24,042	3.531	109	4,769	1.615
-22	177,000	4.733	44	23,399	3.503	110	4,666	1.591
-21	171,079	4.724	45	22,770	3.474	111	4,564	1.567
-20	165,238	4.715	46	22,161	3.445	112	4,467	1.544
-19	159,717	4.705	47	21,573	3.416	113	4,370	1.521
-18	154,344	4.696	48	20,998	3.387	114	4,277	1.498
-17	149,194	4.686	49	20,447	3.357	115	4,185	1.475
-16	144,250	4.676	50	19,903	3.328	116	4,096	1.453
-15	139,443	4.665	51	19,386	3.298	117	4,008	1.431
-14	134,891	4.655	52	18,874	3.268	118	3,923	1.409
-13	130,402	4.644	53	18,384	3.238	119	3,840	1.387
-12	126,183	4.633	54	17,904	3.208	120	3,759	1.366
-11	122,018	4.621	55	17,441	3.178	121	3,681	1.345
-10	118,076	4.609	56	16,991	3.147	122	3,603	1.324
-9	114,236	4.597	57	16,552	3.117	123	3,529	1.304
-8	110,549	4.585	58	16,131	3.086	124	3,455	1.284
-7	107,006	4.572	59	15,714	3.056	125	3,383	1.264
-6	103,558	4.560	60	15,317	3.025	126	3,313	1.244
-5	100,287	4.546	61	14,925	2.994	127	3,244	1.225
-4	97,060	4.533	62	14,549	2.963	128	3,178	1.206
-3	94,020	4.519	63	14,180	2.932	129	3,112	1.187
-2	91,019	4.505	64	13,824	2.901	130	3,049	1.168
-1	88,171	4.490	65	13,478	2.870	131	2,986	1.150
0	85,396	4.476	66	13,139	2.839	132	2,926	1.132
1	82,729	4.461	67	12,814	2.808	133	2,866	1.114
2	80,162	4.445	68	12,493	2.777	134	2,809	1.096
3	77,662	4.429	69	12,187	2.746	135	2,752	1.079
4	75,286	4.413	70	11,884	2.715	136	2,697	1.062
5	72,940	4.397	71	11,593	2.684	137	2,643	1.045
6	70,727	4.380	72	11,308	2.653	138	2,590	1.028
7	68,542	4.363	73	11,031	2.622	139	2,539	1.012
8	66,465	4.346	74	10,764	2.592	140	2,488	0.996
9	64,439	4.328	75	10,501	2.561	141	2,439	0.980
10	62,491	4.310	76	10,249	2.530	142	2,391	0.965
11	60,612	4.292	77	10,000	2.500	143	2,343	0.949
12	58,781	4.273	78	9,762	2.470	144	2,297	0.934
13	57,039	4.254	79	9,526	2.439	145	2,253	0.919
14	55,319	4.235	80	9,300	2.409	146	2,209	0.905
15	53,693	4.215	81	9,078	2.379	147	2,166	0.890
16	52,086	4.195	82	8,862	2.349	148	2,124	0.876
17	50,557	4.174	83	8,653	2.319	149	2,083	0.862
18	49,065	4.153	84	8,448	2.290	150	2,043	0.848
19	47,627	4.132	85	8,251	2.260	151	2,003	0.835
20	46,240	4.111	86	8,056	2.231	152	1,966	0.821
21	44,888	4.089	87	7,869	2.202	153	1,928	0.808
22	43,598	4.067	88	7,685	2.173	154	1,891	0.795
23	42,324	4.044	89	7,507	2.144	155	1,855	0.782
24	41,118	4.021	90	7,333	2.115	156	1,820	0.770
25	39,926	3.998	91	7,165	2.087	157	1,786	0.758
26	38,790	3.975	92	6,999	2.059	158	1,752	0.745
27	37,681	3.951	93	6,838	2.030	159	1,719	0.733
28	36,610	3.927	94	6,683	2.003	160	1,687	0.722
29	35,577	3.903	95	6,530	1.975	161	1,656	0.710
30	34,569	3.878	96	6,383	1.948	162	1,625	0.699
31	33,606	3.853	97	6,238	1.921	163	1,594	0.687
32	32,654	3.828	98	6,098	1.894	164	1,565	0.676
33	31,752	3.802	99	5,961	1.867	165	1,536	0.666
34	30,860	3.776	100	5,827	1.841	166	1,508	0.655
35	30,009	3.750	101	5,698	1.815	167	1,480	0.645
36	29,177	3.723	102	5,571	1.789	168	1,453	0.634
37	28,373	3.697	103	5,449	1.763	169	1,426	0.624
38	27,597	3.670	104	5,327	1.738	170	1,400	0.614
39	26,838	3.654	105	5,210	1.713	171	1,375	0.604
40	26,113	3.615	106	5,095	1.688	172	1,350	0.595

**Table 19 — Temperature (°F) vs Resistance/Voltage Drop Values for OAT, RAT, SAT, and SPT Thermistors (10K at 25°C Type II Resistors) (cont)**

TEMP (F)	RESISTANCE (Ohms)	VOLTAGE DROP (V)	TEMP (F)	RESISTANCE (Ohms)	VOLTAGE DROP (V)	TEMP (F)	RESISTANCE (Ohms)	VOLTAGE DROP (V)
173	1,326	0.585	191	964	0.440	209	714	0.333
174	1,302	0.576	192	947	0.433	210	702	0.328
175	1,278	0.567	193	931	0.426	211	691	0.323
176	1,255	0.558	194	915	0.419	212	680	0.318
177	1,233	0.549	195	900	0.413	213	670	0.314
178	1,211	0.540	196	885	0.407	214	659	0.309
179	1,190	0.532	197	870	0.400	215	649	0.305
180	1,169	0.523	198	855	0.394	216	639	0.300
181	1,148	0.515	199	841	0.388	217	629	0.296
182	1,128	0.507	200	827	0.382	218	620	0.292
183	1,108	0.499	201	814	0.376	219	610	0.288
184	1,089	0.491	202	800	0.370	220	601	0.284
185	1,070	0.483	203	787	0.365	221	592	0.279
186	1,052	0.476	204	774	0.359	222	583	0.275
187	1,033	0.468	205	762	0.354	223	574	0.272
188	1,016	0.461	206	749	0.349	224	566	0.268
189	998	0.454	207	737	0.343	225	557	0.264
190	981	0.447	208	725	0.338			

**Table 20 — Pressure (psig) vs. Voltage Drop Values for Suction Pressure Transducers**

PRESSURE (psig)	VOLTAGE DROP (V)	PRESSURE (psig)	VOLTAGE DROP (V)	PRESSURE (psig)	VOLTAGE DROP (V)	PRESSURE (psig)	VOLTAGE DROP (V)
0	0.465	68	1.135	136	1.804	204	2.474
2	0.485	70	1.154	138	1.824	206	2.493
4	0.505	72	1.174	140	1.844	208	2.513
6	0.524	74	1.194	142	1.863	210	2.533
8	0.544	76	1.214	144	1.883	212	2.553
10	0.564	78	1.233	146	1.903	214	2.572
12	0.583	80	1.253	148	1.922	216	2.592
14	0.603	82	1.273	150	1.942	218	2.612
16	0.623	84	1.292	152	1.962	220	2.631
18	0.642	86	1.312	154	1.982	222	2.651
20	0.662	88	1.332	156	2.001	224	2.671
22	0.682	90	1.351	158	2.021	226	2.690
24	0.702	92	1.371	160	2.041	228	2.710
26	0.721	94	1.391	162	2.060	230	2.730
28	0.741	96	1.410	164	2.080	232	2.749
30	0.761	98	1.430	166	2.100	234	2.769
32	0.780	100	1.450	168	2.119	236	2.789
34	0.800	102	1.470	170	2.139	238	2.809
36	0.820	104	1.489	172	2.159	240	2.828
38	0.839	106	1.509	174	2.178	242	2.848
40	0.859	108	1.529	176	2.198	244	2.868
42	0.879	110	1.548	178	2.218	246	2.887
44	0.898	112	1.568	180	2.237	248	2.907
46	0.918	114	1.588	182	2.257	250	2.927
48	0.938	116	1.607	184	2.277	252	2.946
50	0.958	118	1.627	186	2.297	254	2.966
52	0.977	120	1.647	188	2.316	256	2.986
54	0.997	122	1.666	190	2.336	258	3.005
56	1.017	124	1.686	192	2.356	260	3.025
58	1.036	126	1.706	194	2.375	262	3.045
60	1.056	128	1.726	196	2.395	264	3.065
62	1.076	130	1.745	198	2.415	266	3.084
64	1.095	132	1.765	200	2.434	268	3.104
66	1.115	134	1.785	202	2.454	270	3.124

**Table 21 — Discharge Pressure Transducer (psig) vs. Voltage**

PRESSURE (psig)	VOLTAGE DROP (V)	PRESSURE (psig)	VOLTAGE DROP (V)	PRESSURE (psig)	VOLTAGE DROP (V)	PRESSURE (psig)	VOLTAGE DROP (V)
14.5	0.500	81	0.908	148	1.318	215	1.729
16	0.509	82	0.914	149	1.325	216	1.735
17	0.515	83	0.920	150	1.331	217	1.741
18	0.521	84	0.926	151	1.337	218	1.747
19	0.528	85	0.932	152	1.343	219	1.754
20	0.534	86	0.938	153	1.349	220	1.760
21	0.540	87	0.944	154	1.355	221	1.766
22	0.546	88	0.951	155	1.361	222	1.772
23	0.552	89	0.957	156	1.367	223	1.778
24	0.558	90	0.963	157	1.374	224	1.784
25	0.564	91	0.969	158	1.380	225	1.790
26	0.570	92	0.975	159	1.386	226	1.797
27	0.577	93	0.981	160	1.392	227	1.803
28	0.583	94	0.987	161	1.398	228	1.809
29	0.589	95	0.993	162	1.404	229	1.815
30	0.595	96	1.000	163	1.410	230	1.821
31	0.601	97	1.006	164	1.416	231	1.827
32	0.607	98	1.012	165	1.423	232	1.833
33	0.613	99	1.018	166	1.429	233	1.839
34	0.620	100	1.024	167	1.435	234	1.846
35	0.626	101	1.030	168	1.441	235	1.852
35	0.626	102	1.036	169	1.447	236	1.858
36	0.632	103	1.043	170	1.453	237	1.864
37	0.638	104	1.049	171	1.459	238	1.870
38	0.644	105	1.055	172	1.466	239	1.876
39	0.650	106	1.061	173	1.472	240	1.882
40	0.656	107	1.067	174	1.478	241	1.888
41	0.662	108	1.073	175	1.484	242	1.895
42	0.669	109	1.079	176	1.490	243	1.901
43	0.675	110	1.085	177	1.496	244	1.907
44	0.681	111	1.092	178	1.502	245	1.913
45	0.687	112	1.098	179	1.508	246	1.919
46	0.693	113	1.104	180	1.515	247	1.925
47	0.699	114	1.110	181	1.521	248	1.931
48	0.705	115	1.116	182	1.527	249	1.938
49	0.711	116	1.122	183	1.533	250	1.944
50	0.718	117	1.128	184	1.539	251	1.950
51	0.724	118	1.134	185	1.545	252	1.956
52	0.730	119	1.141	186	1.551	253	1.962
53	0.736	120	1.147	187	1.557	254	1.968
54	0.742	121	1.153	188	1.564	255	1.974
55	0.748	122	1.159	189	1.570	256	1.980
56	0.754	123	1.165	190	1.576	257	1.987
57	0.761	124	1.171	191	1.582	258	1.993
58	0.767	125	1.177	192	1.588	259	1.999
59	0.773	126	1.184	193	1.594	260	2.005
60	0.779	127	1.190	194	1.600	261	2.011
61	0.785	128	1.196	195	1.606	262	2.017
62	0.791	129	1.202	196	1.613	263	2.023
63	0.797	130	1.208	197	1.619	264	2.029
64	0.803	131	1.214	198	1.625	265	2.036
65	0.810	132	1.220	199	1.631	266	2.042
66	0.816	133	1.226	200	1.637	267	2.048
67	0.822	134	1.233	201	1.643	268	2.054
68	0.828	135	1.239	202	1.649	269	2.060
69	0.834	136	1.245	203	1.656	270	2.066
70	0.840	137	1.251	204	1.662	271	2.072
71	0.846	138	1.257	205	1.668	272	2.079
72	0.852	139	1.263	206	1.674	273	2.085
73	0.859	140	1.269	207	1.680	274	2.091
74	0.865	141	1.275	208	1.686	275	2.097
75	0.871	142	1.282	209	1.692	276	2.103
76	0.877	143	1.288	210	1.698	277	2.109
77	0.883	144	1.294	211	1.705	278	2.115
78	0.889	145	1.300	212	1.711	279	2.121
79	0.895	146	1.306	213	1.717	280	2.128
80	0.902	147	1.312	214	1.723	281	2.134

**Table 21 — Discharge Pressure Transducer (psig) vs. Voltage (cont)**

<b>PRESSURE (psig)</b>	<b>VOLTAGE DROP (V)</b>	<b>PRESSURE (psig)</b>	<b>VOLTAGE DROP (V)</b>	<b>PRESSURE (psig)</b>	<b>VOLTAGE DROP (V)</b>	<b>PRESSURE (psig)</b>	<b>VOLTAGE DROP (V)</b>
282	2.140	350	2.557	418	2.974	486	3.390
283	2.146	351	2.563	419	2.980	487	3.397
284	2.152	352	2.569	420	2.986	488	3.403
285	2.158	353	2.575	421	2.992	489	3.409
286	2.164	354	2.581	422	2.998	490	3.415
287	2.170	355	2.587	423	3.004	491	3.421
288	2.177	356	2.593	424	3.010	492	3.427
289	2.183	357	2.600	425	3.016	493	3.433
290	2.189	358	2.606	426	3.023	494	3.439
291	2.195	359	2.612	427	3.029	495	3.446
292	2.201	360	2.618	428	3.035	496	3.452
293	2.207	361	2.624	429	3.041	497	3.458
294	2.213	362	2.630	430	3.047	498	3.464
295	2.220	363	2.636	431	3.053	499	3.470
296	2.226	364	2.643	432	3.059	500	3.476
297	2.232	365	2.649	433	3.066	501	3.482
298	2.238	366	2.655	434	3.072	502	3.488
299	2.244	367	2.661	435	3.078	503	3.495
300	2.250	368	2.667	436	3.084	504	3.501
301	2.256	369	2.673	437	3.090	505	3.507
302	2.262	370	2.679	438	3.096	506	3.513
303	2.269	371	2.685	439	3.102	507	3.519
304	2.275	372	2.692	440	3.108	508	3.525
305	2.281	373	2.698	441	3.115	509	3.531
306	2.287	374	2.704	442	3.121	510	3.538
307	2.293	375	2.710	443	3.127	511	3.544
308	2.299	376	2.716	444	3.133	512	3.550
309	2.305	377	2.722	445	3.139	513	3.556
310	2.311	378	2.728	446	3.145	514	3.562
311	2.318	379	2.734	447	3.151	515	3.568
312	2.324	380	2.741	448	3.157	516	3.574
313	2.330	381	2.747	449	3.164	517	3.580
314	2.336	382	2.753	450	3.170	518	3.587
315	2.342	383	2.759	451	3.176	519	3.593
316	2.348	384	2.765	452	3.182	520	3.599
317	2.354	385	2.771	453	3.188	521	3.605
318	2.361	386	2.777	454	3.194	522	3.611
319	2.367	387	2.784	455	3.200	523	3.617
320	2.373	388	2.790	456	3.206	524	3.623
321	2.379	389	2.796	457	3.213	525	3.629
322	2.385	390	2.802	458	3.219	526	3.636
323	2.391	391	2.808	459	3.225	527	3.642
324	2.397	392	2.814	460	3.231	528	3.648
325	2.403	393	2.820	461	3.237	529	3.654
326	2.410	394	2.826	462	3.243	530	3.660
327	2.416	395	2.833	463	3.249	531	3.666
328	2.422	396	2.839	464	3.256	532	3.672
329	2.428	397	2.845	465	3.262	533	3.679
330	2.434	398	2.851	466	3.268	534	3.685
331	2.440	399	2.857	467	3.274	535	3.691
332	2.446	400	2.863	468	3.280	536	3.697
333	2.452	401	2.869	469	3.286	537	3.703
334	2.459	402	2.875	470	3.292	538	3.709
335	2.465	403	2.882	471	3.298	539	3.715
336	2.471	404	2.888	472	3.305	540	3.721
337	2.477	405	2.894	473	3.311	541	3.728
338	2.483	406	2.900	474	3.317	542	3.734
339	2.489	407	2.906	475	3.323	543	3.740
340	2.495	408	2.912	476	3.329	544	3.746
341	2.502	409	2.918	477	3.335	545	3.752
342	2.508	410	2.925	478	3.341	546	3.758
343	2.514	411	2.931	479	3.347	547	3.764
344	2.520	412	2.937	480	3.354	548	3.770
345	2.526	413	2.943	481	3.360	549	3.777
346	2.532	414	2.949	482	3.366	550	3.783
347	2.538	415	2.955	483	3.372	551	3.789
348	2.544	416	2.961	484	3.378	552	3.795
349	2.551	417	2.967	485	3.384	553	3.801



**Table 21 — Discharge Pressure Transducer (psig) vs. Voltage (cont)**

PRESSURE (psig)	VOLTAGE DROP (V)	PRESSURE (psig)	VOLTAGE DROP (V)	PRESSURE (psig)	VOLTAGE DROP (V)	PRESSURE (psig)	VOLTAGE DROP (V)
554	3.807	583	3.985	612	4.163	641	4.341
555	3.813	584	3.991	613	4.169	642	4.347
556	3.820	585	3.997	614	4.175	643	4.353
557	3.826	586	4.003	615	4.181	644	4.359
558	3.832	587	4.010	616	4.187	645	4.365
559	3.838	588	4.016	617	4.193	646	4.371
560	3.844	589	4.022	618	4.200	647	4.377
561	3.850	590	4.028	619	4.206	648	4.384
562	3.856	591	4.034	620	4.212	649	4.390
563	3.862	592	4.040	621	4.218	650	4.396
564	3.869	593	4.046	622	4.224	651	4.402
565	3.875	594	4.052	623	4.230	652	4.408
566	3.881	595	4.059	624	4.236	653	4.414
567	3.887	596	4.065	625	4.243	654	4.420
568	3.893	597	4.071	626	4.249	655	4.426
569	3.899	598	4.077	627	4.255	656	4.433
570	3.905	599	4.083	628	4.261	657	4.439
571	3.911	600	4.089	629	4.267	658	4.445
572	3.918	601	4.095	630	4.273	659	4.451
573	3.924	602	4.102	631	4.279	660	4.457
574	3.930	603	4.108	632	4.285	661	4.463
575	3.936	604	4.114	633	4.292	662	4.469
576	3.942	605	4.120	634	4.298	663	4.475
577	3.948	606	4.126	635	4.304	664	4.482
578	3.954	607	4.132	636	4.310	665	4.488
579	3.961	608	4.138	637	4.316	666	4.494
580	3.967	609	4.144	638	4.322	667	4.500
581	3.973	610	4.151	639	4.328		
582	3.979	611	4.157	640	4.334		

## MAJOR SYSTEM COMPONENTS

### General

The 50FCQ and 50GCQ single package rooftop heat pump units are available with the factory-installed optional SystemVu electronic control system that monitors all operations of the rooftop. The control system is composed of several main control components and available factory-installed options or field-installed accessories as listed in sections below. See Fig. 13-20 for examples of typical control and power schematics.

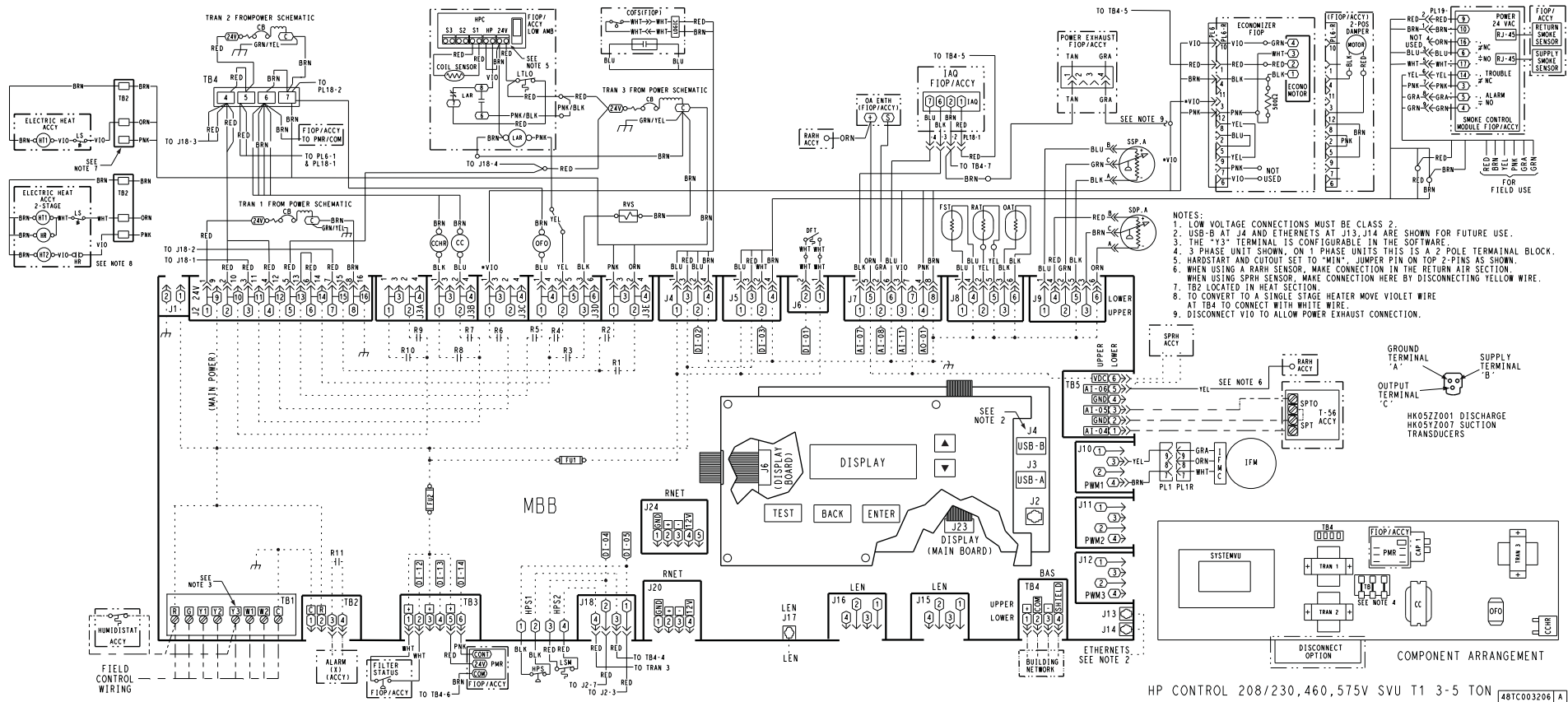


Fig. 13 — 50FCQ 04-06 SystemVu Control Schematic

HP CONTROL 208/230,460,575V SVU T1 3-5 TON 48TC003206 A

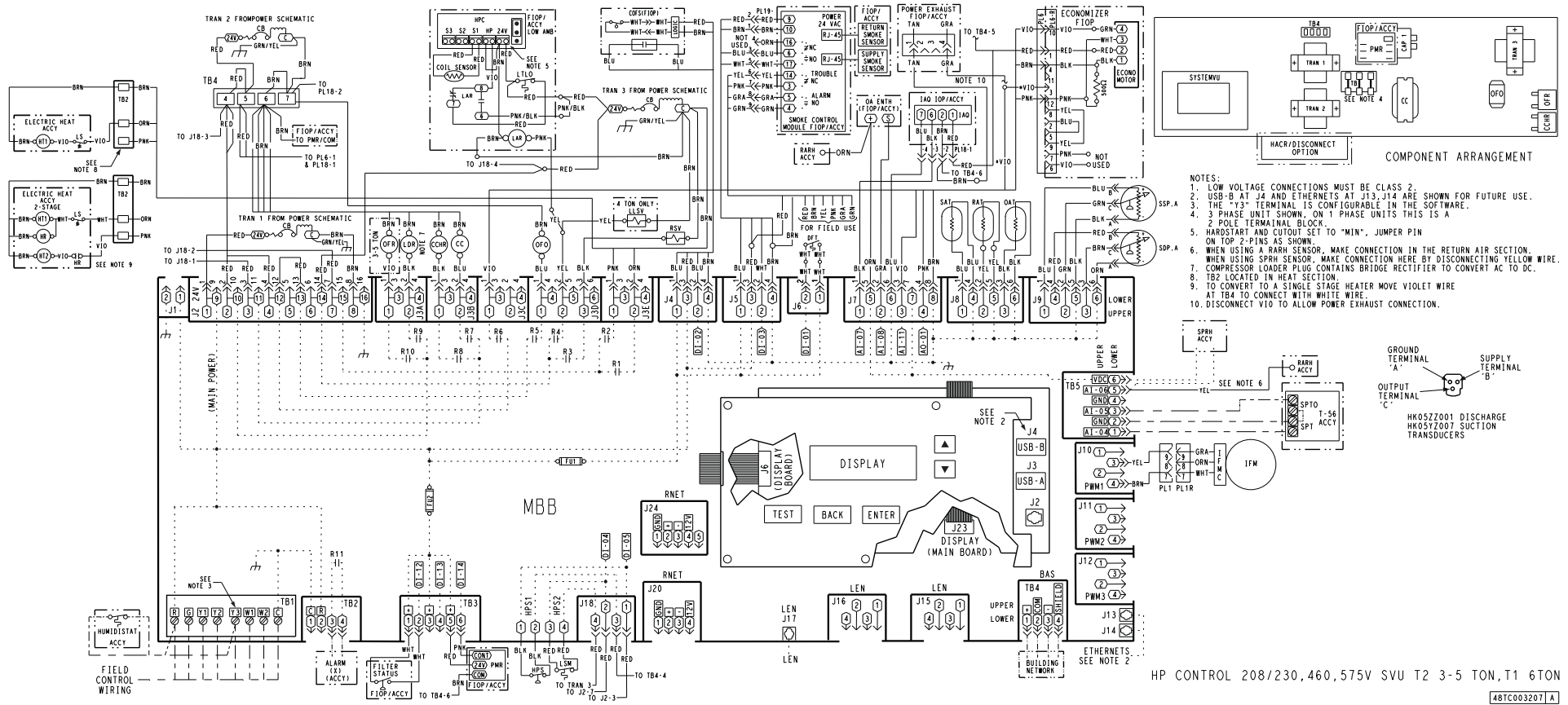


Fig. 14 — 50FCQ 07 and 50GCQ 04-06 SystemVu Control Schematic

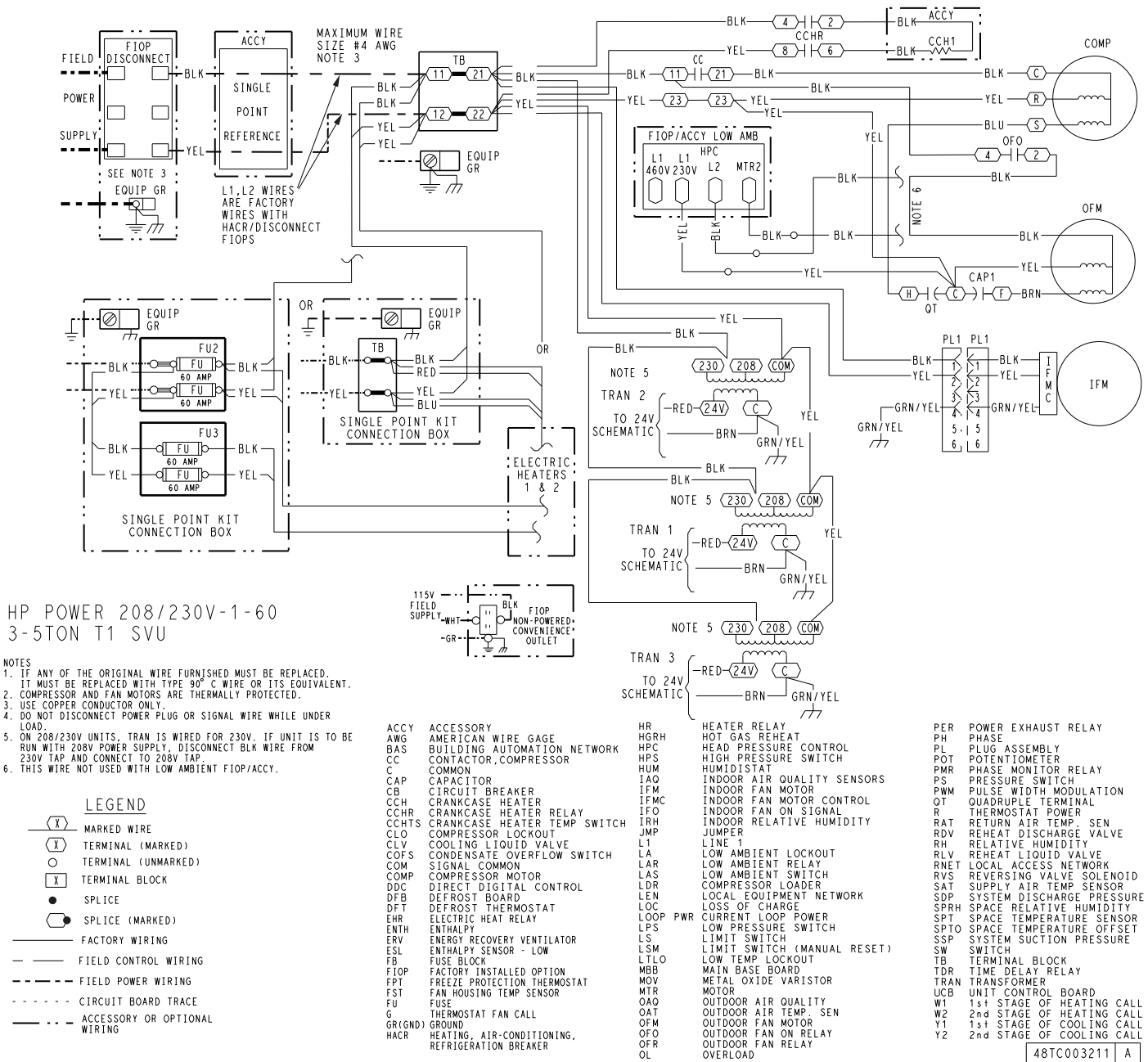


Fig. 15 — 50FCQ 04-06 SystemVu Power Schematic (208/230V-1-60 unit)

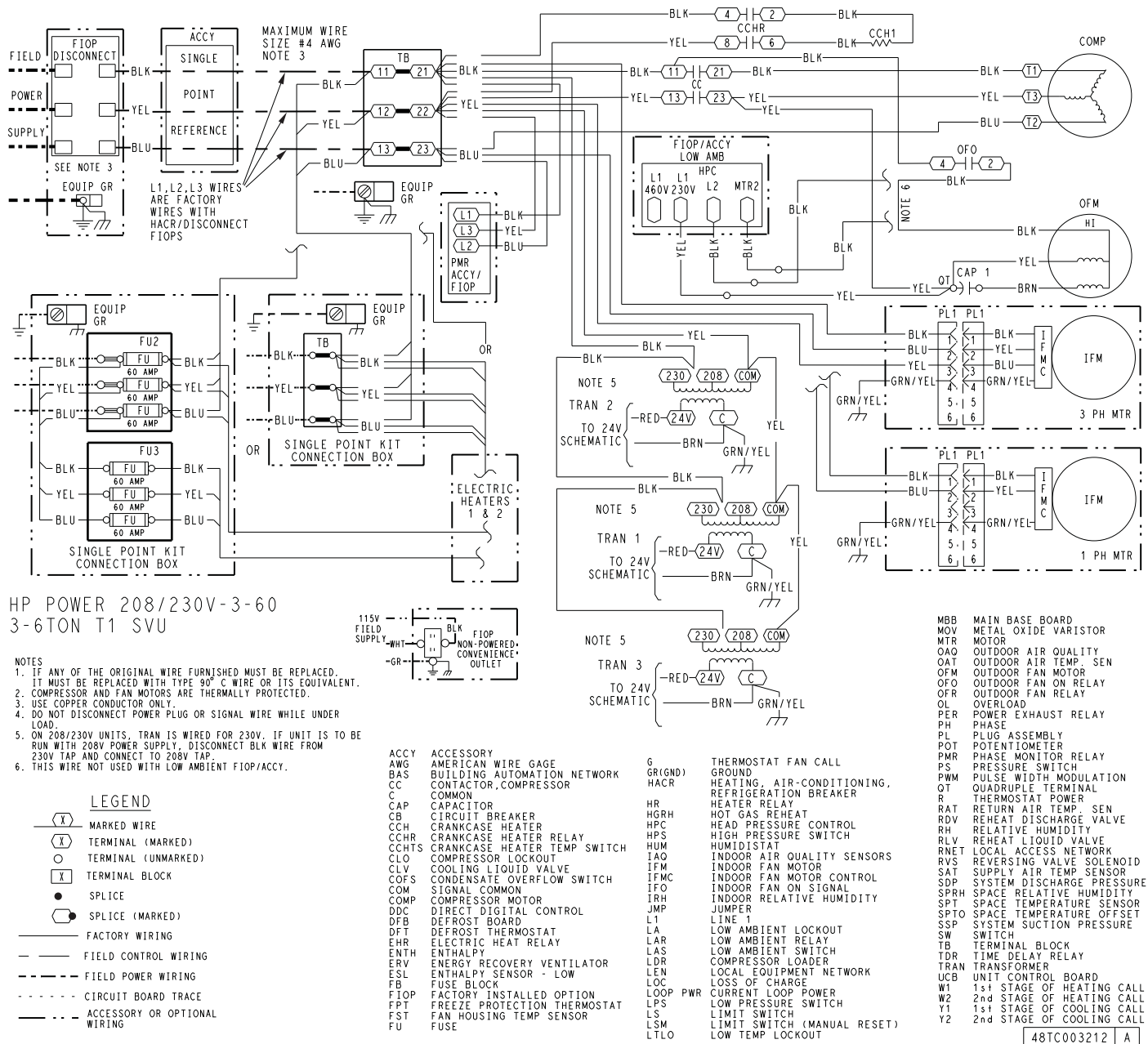
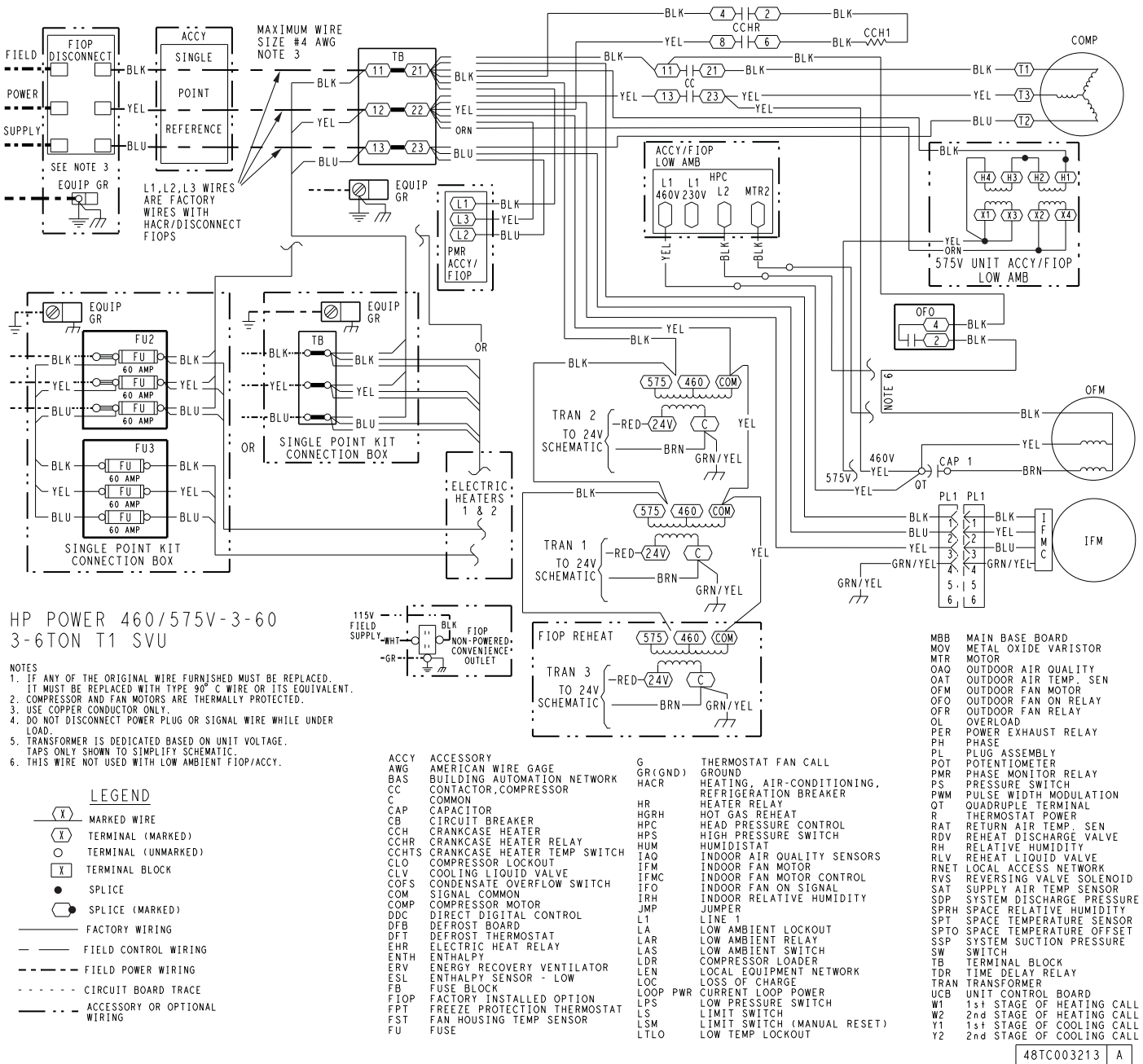
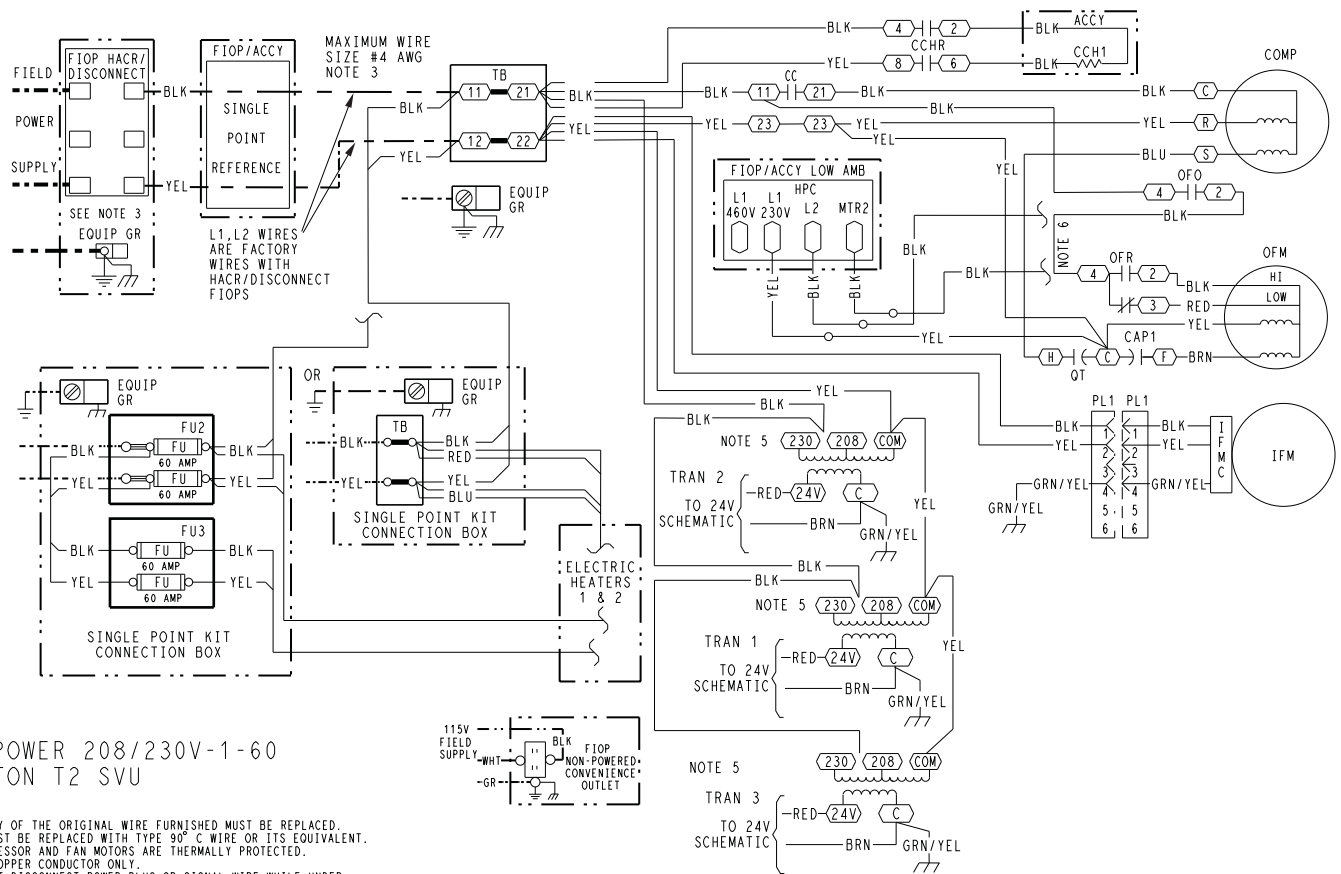


Fig. 16 — 50GCQ 04-07 SystemVu Power Schematic (208/230V-3-60 unit)



**Fig. 17 — 50FCQ 04-07 SystemVu Power Schematic (460/575V-3-60 unit)**



HP POWER 208/230V-1-60  
3-5TON T2 SVU

- NOTES
1. IF ANY OF THE ORIGINAL WIRE FURNISHED MUST BE REPLACED, IT MUST BE REPLACED WITH TYPE 90° C WIRE OR ITS EQUIVALENT.
  2. COMPRESSOR AND FAN MOTORS ARE THERMALLY PROTECTED.
  3. USE COPPER CONDUCTOR ONLY.
  4. DO NOT DISCONNECT POWER PLUG OR SIGNAL WIRE WHILE UNDER LOAD.
  5. ON 208/230V UNITS, TRAN IS WIRED FOR 230V. IF UNIT IS TO BE RUN WITH 208V POWER SUPPLY, DISCONNECT BLK WIRE FROM 230V TAP AND CONNECT TO 208V TAP.
  6. THIS WIRE NOT USED WITH LOW AMBIENT FIOF/ACCY.

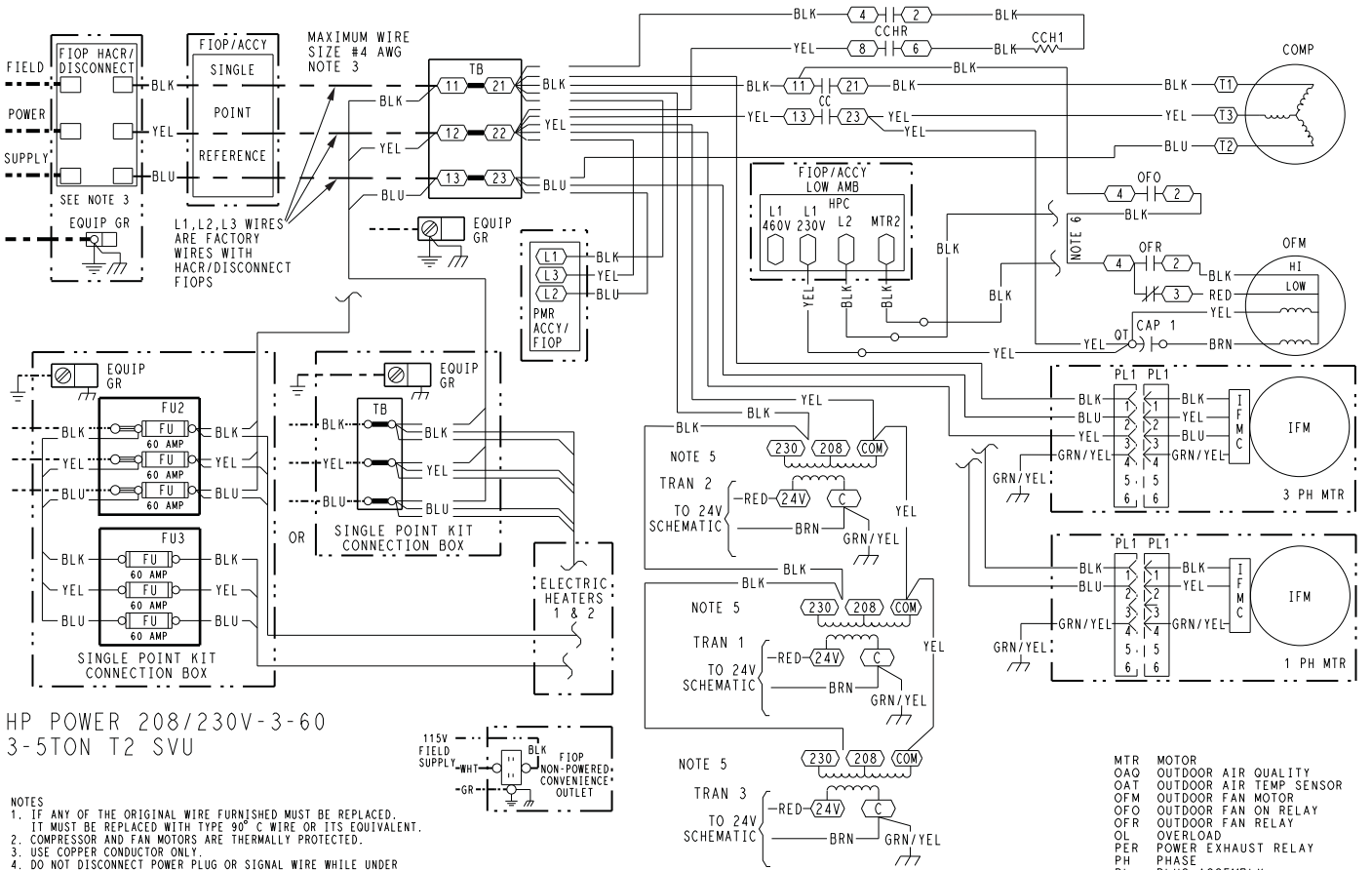
**LEGEND**

- MARKED WIRE
- TERMINAL (MARKED)
- TERMINAL (UNMARKED)
- TERMINAL BLOCK
- SPLICE
- SPLICE (MARKED)
- FACTORY WIRING
- FIELD CONTROL WIRING
- FIELD POWER WIRING
- CIRCUIT BOARD TRACE
- ACCESSORY OR OPTIONAL WIRING

- |         |  |      |                             |      |                           |
|---------|--|------|-----------------------------|------|---------------------------|
| ACCY    | ACCESSORY  | HR   | HEATER RELAY                | PER  | POWER EXHAUST RELAY       |
| AWG     | AMERICAN WIRE GAGE                               | HGRH | HOT GAS REHEAT              | PH   | PHASE                     |
| BAS     | BUILDING AUTOMATION NETWORK                      | HPC  | HEAD PRESSURE CONTROL       | PL   | PLUG ASSEMBLY             |
| CC      | CONTACTOR, COMPRESSOR                            | HPS  | HIGH PRESSURE SWITCH        | POT  | POTENTIOMETER             |
| C       | COMMON   | HUM  | HUMIDISTAT                  | PMR  | PHASE MONITOR RELAY       |
| CAP     | CAPACITOR  | IAQ  | INDOOR AIR QUALITY SENSORS  | PS   | PRESSURE SWITCH           |
| CB      | CIRCUIT BREAKER                                  | IFM  | INDOOR FAN MOTOR            | PWM  | PULSE WIDTH MODULATION    |
| CCH     | CRANKCASE HEATER                                 | IFMC | INDOOR FAN MOTOR CONTROL    | QT   | QUADRUPLE TERMINAL        |
| CCHR    | CRANKCASE HEATER RELAY                           | IFO  | INDOOR FAN ON SIGNAL        | R    | THERMOSTAT POWER          |
| CCHTS   | CRANKCASE HEATER TEMP SWITCH                     | IRH  | INDOOR RELATIVE HUMIDITY    | RAT  | RETURN AIR TEMP. SEN      |
| CLO     | COMPRESSOR LOCKOUT                               | JMP  | JUMPER                      | RDV  | REHEAT DISCHARGE VALVE    |
| CLV     | COOLING LIQUID VALVE                             | LA   | LOW AMBIENT LOCKOUT         | RH   | RELATIVE HUMIDITY         |
| COFS    | CONDENSATE OVERFLOW SWITCH                       | LAR  | LOW AMBIENT RELAY           | RLV  | REHEAT LIQUID VALVE       |
| COM     | SIGNAL COMMON                                    | LAS  | LOW AMBIENT SWITCH          | RNET | LOCAL ACCESS NETWORK      |
| COMP    | COMPRESSOR MOTOR                                 | LDR  | COMPRESSOR LOADER           | RVS  | REVERSING VALVE SOLENOID  |
| DDC     | DIRECT DIGITAL CONTROL                           | LEN  | LOCAL EQUIPMENT NETWORK     | SAT  | SUPPLY AIR TEMP SENSOR    |
| DFB     | DEFROST BOARD                                    | LOC  | LOSS OF CHARGE              | SDP  | SYSTEM DISCHARGE PRESSURE |
| DFT     | DEFROST THERMOSTAT                               | LPS  | LOW PRESSURE SWITCH         | SPR  | SPACE RELATIVE HUMIDITY   |
| EHR     | ELECTRIC HEAT RELAY                              | LSM  | LIMIT SWITCH (MANUAL RESET) | SPT  | SPACE TEMPERATURE SENSOR  |
| ENTH    | ENTHALPY   | LTL  | LOW TEMP LOCKOUT            | SPTO | SPACE TEMPERATURE OFFSET  |
| ERV     | ENERGY RECOVERY VENTILATOR                       | MTR  | MOTOR                       | SSP  | SYSTEM SUCTION PRESSURE   |
| ESL     | ENTHALPY SENSOR - LOW                            | OAO  | OUTDOOR AIR QUALITY         | SW   | SWITCH                    |
| FB      | FUSE BLOCK                                       | OAT  | OUTDOOR AIR TEMP. SEN       | TB   | TERMINAL BLOCK            |
| FIOF    | FACTORY INSTALLED OPTION                         | OAT  | OUTDOOR AIR TEMP. SEN       | TR   | TIME DELAY RELAY          |
| FPT     | FREEZE PROTECTION THERMOSTAT                     | OFO  | OUTDOOR FAN MOTOR           | TRAN | TRANSFORMER               |
| FST     | FAN HOUSING TEMP SENSOR                          | OFO  | OUTDOOR FAN ON RELAY        | UCB  | UNIT CONTROL BOARD        |
| FU      | FUSE   | OFR  | OUTDOOR FAN RELAY           | W1   | 1st STAGE OF HEATING CALL |
| G       | THERMOSTAT FAN CALL                              | OL   | OVERLOAD                    | W2   | 2nd STAGE OF HEATING CALL |
| GR(GND) | GROUND   |      |                             | Y1   | 1st STAGE OF COOLING CALL |
| HACR    | HEATING, AIR-CONDITIONING, REFRIGERATION BREAKER |      |                             | Y2   | 2nd STAGE OF COOLING CALL |

48TC003208 A

**Fig. 18 — 50GCQ 04-06 SystemVu Power Schematic (208/230V-1-60 unit)**



HP POWER 208/230V-3-60  
3-5TON T2 SVU

- NOTES
1. IF ANY OF THE ORIGINAL WIRE FURNISHED MUST BE REPLACED, IT MUST BE REPLACED WITH TYPE 90° C WIRE OR ITS EQUIVALENT.
  2. COMPRESSOR AND FAN MOTORS ARE THERMALLY PROTECTED.
  3. USE COPPER CONDUCTOR ONLY.
  4. DO NOT DISCONNECT POWER PLUG OR SIGNAL WIRE WHILE UNDER LOAD.
  5. ON 208/230V UNITS, TRAN IS WIRED FOR 230V. IF UNIT IS TO BE RUN WITH 208V POWER SUPPLY, DISCONNECT BLK WIRE FROM 230V TAP AND CONNECT TO 208V TAP.
  6. THIS WIRE NOT USED WITH LOW AMBIENT FIOF/ACCY.

**LEGEND**

- (X) MARKED WIRE
- (X) TERMINAL (MARKED)
- (O) TERMINAL (UNMARKED)
- (X) TERMINAL BLOCK
- (•) SPLICE
- (•) SPLICE (MARKED)
- FACTORY WIRING
- - - FIELD CONTROL WIRING
- - - FIELD POWER WIRING
- - - - - CIRCUIT BOARD TRACE
- - - - - ACCESSORY OR OPTIONAL WIRING

- ACCY ACCESSORY
- AWG AMERICAN WIRE GAGE
- BAS BUILDING AUTOMATION NETWORK
- CC CONTACTOR, COMPRESSOR
- C COMMON
- CAP CAPACITOR
- CB CIRCUIT BREAKER
- CCH CRANKCASE HEATER
- CCHR CRANKCASE HEATER RELAY
- CCHTS CRANKCASE HEATER TEMP SWITCH
- CLO COMPRESSOR LOCKOUT
- CLV COOLING LIQUID VALVE
- COFS CONDENSATE OVERFLOW SWITCH
- COM SIGNAL COMMON
- COMP COMPRESSOR MOTOR
- DDC DIRECT DIGITAL CONTROL
- DFB DEFROST BOARD
- DFT DEFROST THERMOSTAT
- EHR ELECTRIC HEAT RELAY
- ENTH ENTHALPY HEAT RELAY
- ERV ENERGY RECOVERY VENTILATOR
- ESL ENTHALPY SENSOR - LOW
- FB FUSE BLOCK
- FIOF FACTORY INSTALLED OPTION
- FPT FREEZE PROTECTION THERMOSTAT
- FST FAN HOUSING TEMP SENSOR
- FU FUSE

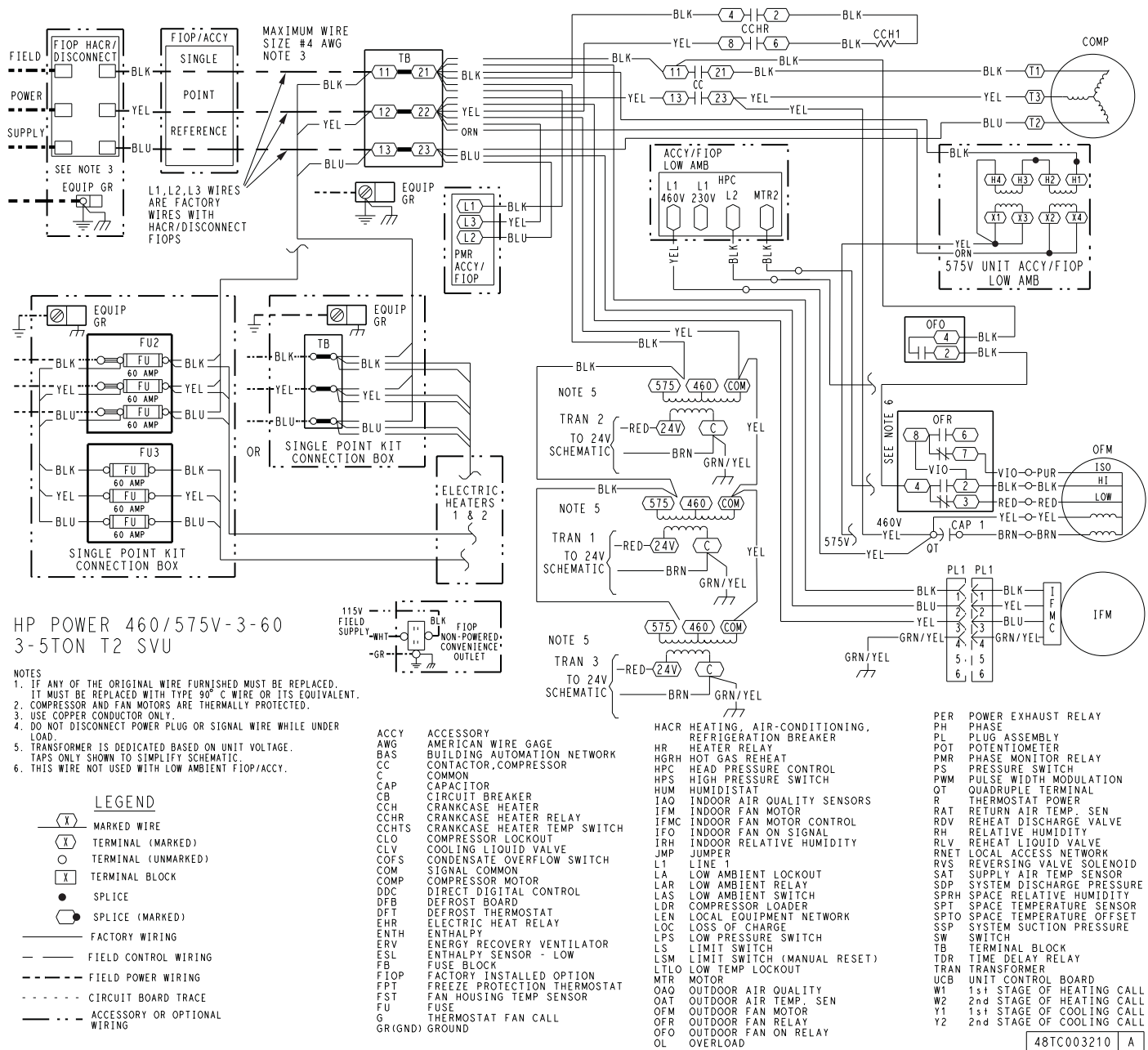
- G (GR/GND) GROUND
- HACR HEATING, AIR-CONDITIONING, REFRIGERATION BREAKER
- HR HEATER RELAY
- HGRH HOT GAS REHEAT
- HPC HEAD PRESSURE CONTROL
- HPS HIGH PRESSURE SWITCH
- HUM HUMIDISTAT
- IAO INDOOR AIR QUALITY SENSORS
- IFM INDOOR FAN MOTOR
- IFMC INDOOR FAN MOTOR CONTROL
- IFO INDOOR FAN ON SIGNAL
- IRH INDOOR RELATIVE HUMIDITY JUMPER
- JMP JUMPER
- L1 LINE 1
- LA LOW AMBIENT LOCKOUT
- LAR LOW AMBIENT RELAY
- LAS LOW AMBIENT SWITCH
- LDR COMPRESSOR LOADER
- LEN LOCAL EQUIPMENT NETWORK
- LOC LOSS OF CHARGE
- LPS LOW PRESSURE SWITCH
- LS LIMIT SWITCH
- LSM LIMIT SWITCH (MANUAL RESET)
- LTO LOW TEMP LOCKOUT

- MTR MOTOR
- OAQ OUTDOOR AIR QUALITY
- OAT OUTDOOR AIR TEMP SENSOR
- OFM OUTDOOR FAN MOTOR
- OFO OUTDOOR FAN ON RELAY
- OFR OUTDOOR FAN RELAY
- OL OVERLOAD
- PER POWER EXHAUST RELAY
- PH PHASE
- PL PLUG ASSEMBLY
- POT POTENTIOMETER
- PMR PHASE MONITOR RELAY
- PS PRESSURE SWITCH
- PWM PULSE WIDTH MODULATION
- QTR QUADRUPLE TERMINAL
- R THERMOSTAT POWER
- RAT RETURN AIR TEMP SENSOR
- RDV REHEAT DISCHARGE VALVE
- RH RELATIVE HUMIDITY
- RLV REHEAT LIQUID VALVE
- RNET LOCAL ACCESS NETWORK
- RVS REVERSING VALVE SOLENOID
- SAT SUPPLY AIR TEMP SENSOR
- SDP SYSTEM DISCHARGE PRESSURE
- SPRH SPACE RELATIVE HUMIDITY
- SPT SPACE TEMPERATURE SENSOR
- SPTO SPACE TEMPERATURE OFFSET
- SSP SYSTEM SUCTION PRESSURE
- SW SWITCH
- TB TERMINAL BLOCK
- TDR TIME DELAY RELAY
- TRAN TRANSFORMER
- UCB UNIT CONTROL BOARD
- W1 1st STAGE OF HEATING CALL
- W2 2nd STAGE OF HEATING CALL
- Y1 1st STAGE OF COOLING CALL
- Y2 2nd STAGE OF COOLING CALL

48TC003209 | A

**Fig. 19 — 50GCQ 04-06 SystemVu Power Schematic (208/230V-3-60 unit)**

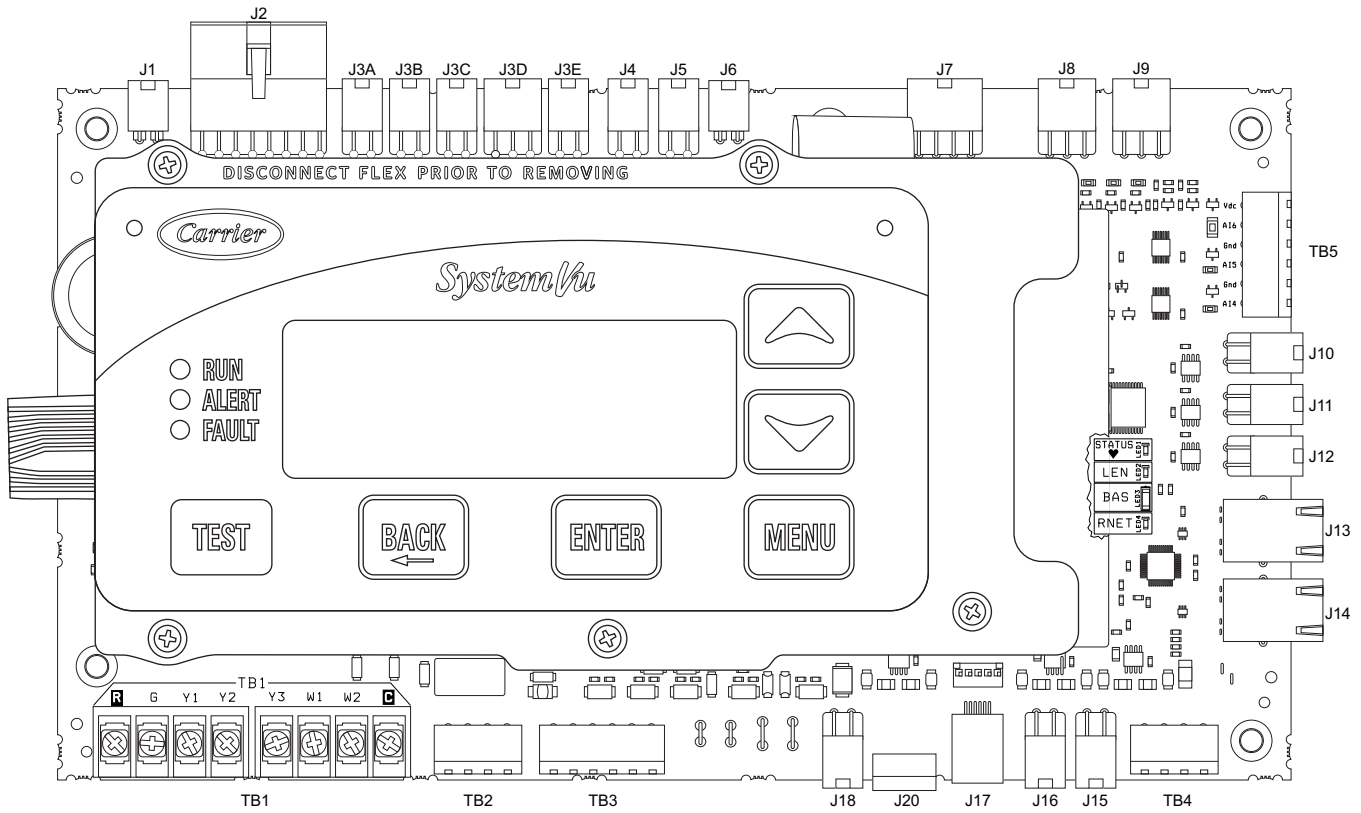




**Fig. 20 — 50GCQ 04-06 SystemVu Power Schematic (460/575V-3-60 unit)**

## Main Base Board (MBB)

See Fig. 21 and Table 22. The majority of the I/O is connected to the MBB which executes the controls operation of the unit from the software that is loaded onto it.



**Fig. 21 — Main Base Board (MBB)**

**Table 22 — Main Base Board (MBB) Connections**

DISPLAY NAME	SENSOR LOCATION	I/O TYPE	POINT NAME	CONNECTION PIN NUMBER
<b>INPUTS</b>				
Input power from TRAN2	Control Box	24 VAC		J2, 1 and 8
Configurable (COFS)	Drain Pan	24 VAC	COFS	J4, 1- 4
Configurable (FIRE SHUTDOWN)	Supply/Return/Space	Switch Input	FIREDOWN	J5, 1- 4
DEFROST SWITCH	Outdoor Coil	Switch Input	DFRST_SW	J6, 1- 2
Configurable (IAQ LEVEL)	Return/Space	0- 20 mA	IAQ	J7, 1, 5-6
Configurable (OARH LEVEL)	Economizer	0- 20 mA	OARH	J7, 2, 6-7
ECON ACT POSITION	Economizer	2- 10vdc	DAMPPOS	J7, 3, 8
FAN SUPPLY TEMP	Indoor fan deck	10k thermistor	FST	J8, 1, 4
RETURN AIR TEMP	Return	10k thermistor	RAT	J8, 2, 5
OUTDOOR AIR TEMP	Outdoor coil	10k thermistor	OAT	J8, 3, 6
CIR.A SUC. PRESS	Circuit A Suction pipe	0-5 VDC pressure transducer	SSP_A	J9, 1- 2, 5
CIR.A DIS. PRESS	Circuit A Discharge pipe	0-5 VDC pressure transducer	SDP_A	J9, 4- 3, 6
Configurable		0- 20 mA		TB5, 4- 6
SLIDER OFFSET VAL	Space	10k thermistor	SPTO	TB5, 2- 3
SPACE TEMPERATURE	Space	10k thermistor	SPACE_T	TB5, 1- 2
CIR.A HPS Circuit A	Discharge pipe	Switch Input	CIRA_HPS	QC, 1-2J18, 1, 3
IDF LIMIT SWITCH	Indoor Fan	Switch Input	IDF_LSM	QC, 3-4J18, 2,4
Configurable (FILTER STATUS SW)	FIOP/Field-installed	Switch Input	FILTSAT	TB3, 1- 2
Configurable	Field- installed	Switch Input		TB3, 3- 4
Configurable (PHASE MONITOR SW)	Control Box	Switch Input	PWR_STAT	TB3, 5- 6
TSTAT G INPUT	Space	Switch Input	G	TB1, G
TSTAT Y1 INPUT	Space	Switch Input	Y1	TB1, Y1
TSTAT Y2 INPUT	Space	Switch Input	Y2	TB1, Y2
Configurable (HUMIDISTAT)	Field-Installed	Switch Input	HUMDSTAT	TB1, Y3
TSTAT W1 INPUT	Space	Switch Input	W1	TB1, W1
TSTAT W2 INPUT	Space	Switch Input	W2	TB1, W2
<b>OUTPUTS</b>				
Optional power out	Not Used	24 VAC		J1, 1- 2
ECON CMD POSITION		0- 20 mA	DAMPCMD	J7, 4, 8
COMMANDED IDF RPM	Indoor fan section	PWM1	FSPD_RPM	J10, 1-4
not used		PWM2		J11, 1-4
not used		PWM3		J12, 1-4
Configurable (ALARM RELAY)		Relay 11	ALMOUT	TB2, 3- 4
ODF SPEED RELAY	Not Used	Relay 10	OFR	J3A, 1, 3
COMP A LOADER	Not Used	Relay 9	COMP_ALD	J3A, 2, 4
CCH RELAY	Not Used	Relay 8	CCHR1	J3B, 1, 3
COMPRESSOR A1	Not Used	Relay 7	COMP_A1	J3B, 2, 4
Configurable (PE1 RELAY)		Relay 6	PE1	J3C, 1- 4
ODF ON/OFF RELAY		Relay 5	ODF_ON	J3D, 1, 4
LIQUID LINE VALVE		Relay 4	LLSV	J3D, 2, 5
REVERSING VALVE		Relay 3	RVS_A	J3D, 3, 6
HEAT 2 RELAY		Relay	HEAT_2	J3E, 1, 3
HEAT 1 RELAY		Relay	HEAT_1	J3E, 2, 4
<b>COMMUNICATION</b>				
Building Automated System (BAS)	Building	Communication		TB4, 1- 5
Ethernet	Not Used	Communication		J13, J14
Expansion LEN Bus	Not Used	Communication		J15, 1-4
Expansion LEN Bus	Not Used	Communication		J16, 1-4
Local Equipment Network (LEN)		Communication		J17
RNET Sensors	Building	Communication		J20, 1-4
Display Copper Cable		Communication		J23
RNET Service Access		Communication		J24, 1-5
<b>DISPLAY CONNECTIONS</b>				
Display Copper Cable		Communication		J1
Local Equipment Network (LEN)		Communication		J2
USB- A		Communication		J3
USB- B	Not Used	Communication		J4
Keypad Ribbon Cable		Communication		J6

## Protective Devices

### COMPRESSOR PROTECTION

#### **Overcurrent**

Each compressor has internal line break motor protection.

#### **Overtemperature**

Each compressor has an internal protector to protect it against excessively high discharge gas temperatures.

#### **High-Pressure Switch**

If the high-pressure switch trips, the compressor will shut down and the Circuit A High Pressure Alert will activate. Refer to the alarm section for the High pressure alert.

### EVAPORATOR FAN MOTOR PROTECTION

The ECM motor is protected from locked rotor and over-current protection through the electronic control module attached to the motor.

### CONDENSER FAN MOTOR PROTECTION

The motor is internally protected against overload.

### SATURATED SUCTION PRESSURE (SSP)

If the SSP for a particular circuit is reading below the alarm set point for an extended period of time, that circuit will be shut down. After 15 minutes, the alarm will automatically reset. If this alarm occurs 3 times consecutively, the circuit will remain locked out until an alarm reset is initiated via CCN or manually via the SystemVu controller display (see Alarms and Alerts section for more details).

### CONDENSATE OVERFLOW SWITCH (COFS)

A separate factory installed device can detect a full drain pan. This device consists of a pan sensor to detect the water level and a relay control switch to read the sensor. The control switch is located in the supply fan section and feeds into the SystemVu control to trip a condensate overflow fault. The relay switch is a normally open device that closes when power is applied. If the sensor detects high water levels for 10 seconds straight, it will open the contact removing the input provided to the SystemVu control. The switch will also turn its red LED on. If the water level is low enough for 5 minutes the relay will close again applying the input back to the SystemVu controller. A blinking red LED on the switch indicates that the sensor has been disconnected.

## Space Mounted Sensors

### SPACE TEMPERATURE SENSOR (T-55)

The T-55 space temperature sensor (part no. 33ZCT55SPT) is a field-installed accessory. The sensor is installed on a building interior wall to measure room air temperature. The T-55 sensor also includes an override button on the front cover to permit occupants to override the Unoccupied Schedule (if programmed).

TB5-1 ..... Sensor Input

TB5-2 ..... Sensor Common

### SPACE TEMPERATURE SENSOR (T-56)

The T-56 space temperature sensor (part no. 33ZCT56SPT) is a field-installed accessory. This sensor includes a sliding scale on the front cover that permits an occupant to adjust the space temperature set point remotely. The T-56 sensor also includes an override button on the front cover to allow occupants to override the unoccupied schedule (if programmed).

TB5-1 ..... Sensor Input

TB5-2 ..... Sensor Common

TB5-2 ..... Setpoint Offset Input

#### **Space Temperature Sensor Averaging**

See Fig. 22 for space temperature averaging with T-55 sensors only. If the use of one T-56 sensor is required, refer to Fig. 23.

### ZS SPACE SENSOR

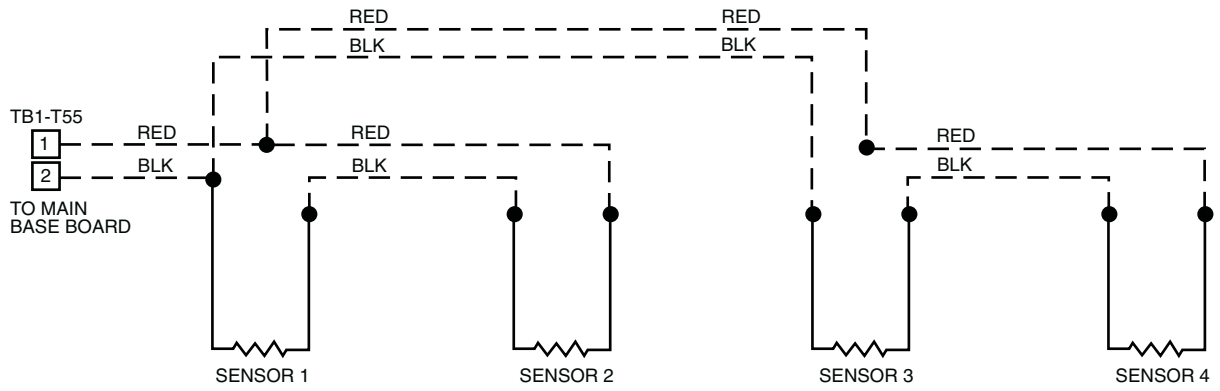
The ZS Standard, Plus, or Pro can be wired into J20 or J24 of the SystemVu controller, J20 provides an easy field connection plug. A maximum of 5 ZS sensors can be connected but a separate power supply may be needed. Use the ZS SENSOR CFG menu (**SETTINGS** → **NETWORK SETTINGS**) when setting up the ZS sensors in SystemVu. The Sensor addresses have to be unique and set in the actual sensors via DIP also. The Typical default for the ZS Sensor is address 1. Follow the ZS installation instruction for further details on the sensors. ZS sensor data can be monitored on SystemVu in the ZS Sensor Info menu (**INPUTS** → **NETWORK** → **ZS SENSOR INFO**).

J20-1 ..... Sensor Common

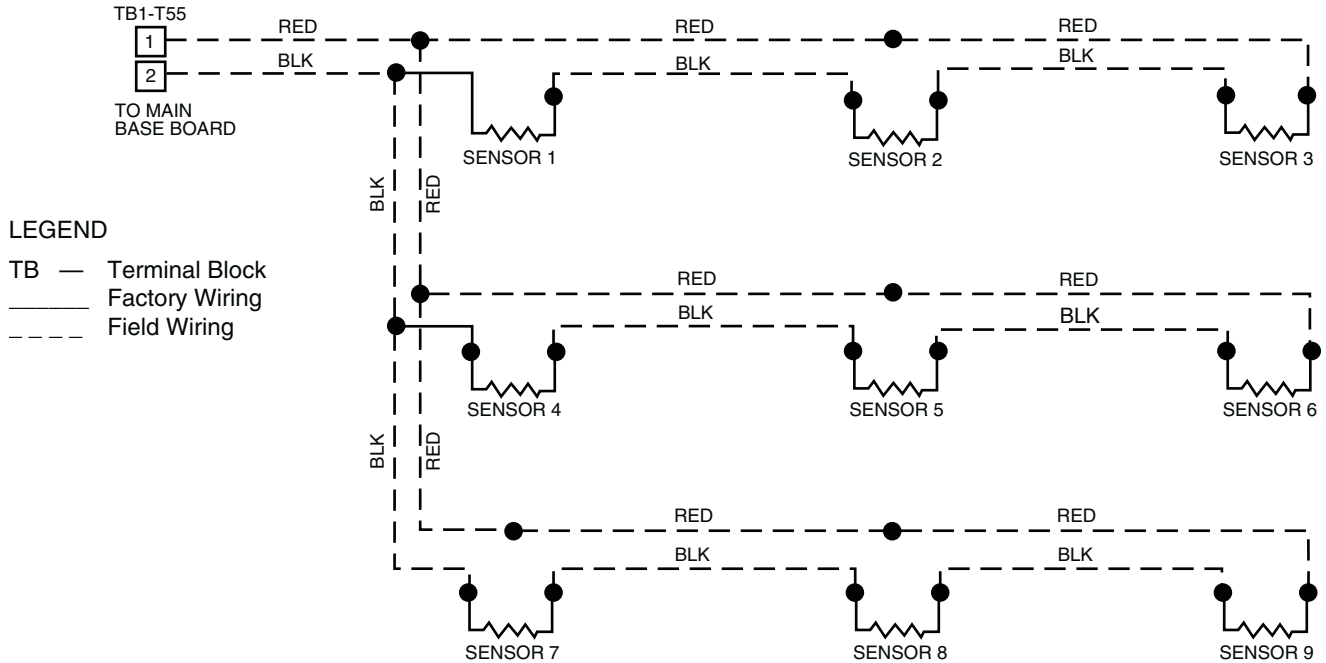
J20-2 ..... Sensor Communication Positive (+)

J20-3 ..... Sensor Communication Negative (-)

J20-4 ..... Sensor +12vdc Power

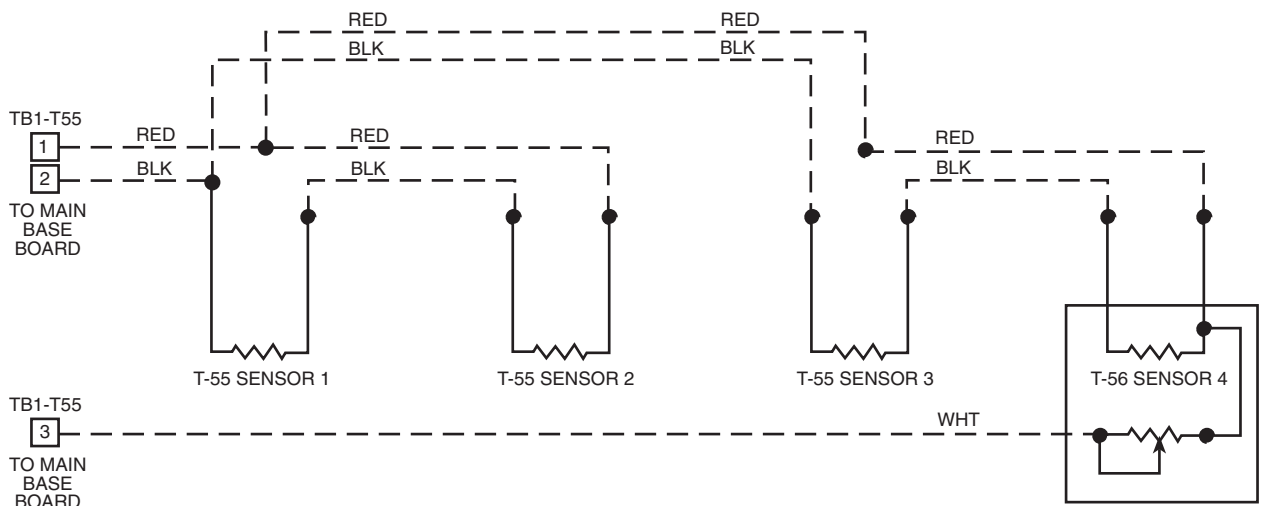


SPACE TEMPERATURE AVERAGING – 4 T-55 SENSOR APPLICATION



SPACE TEMPERATURE AVERAGING – 9 T-55 SENSOR APPLICATION

**Fig. 22 — Space Temperature Sensor Averaging**



**Fig. 23 — Space Temperature Sensor Averaging with 3 T-55 Sensors and One T-56 Sensor**

## Carrier Comfort Network (CCN) Interface

The units can be connected to the CCN if desired. The communication bus wiring is a shielded, 3-conductor cable with drain wire and is field supplied and installed. The system elements are connected to the communication bus in a daisy chain arrangement. (See Fig. 24.) The positive pin of each system element communication connector must be wired to the positive pins of the system elements on either side of it. This is also required for the negative and signal ground pins of each system element. Wiring connections for CCN should be made at the CIB. (See Fig. 13 and 14.) Consult the CCN Contractor's Manual for further information.

NOTE: Conductors and drain wire must be 20 AWG (American Wire Gauge) minimum stranded, tinned copper. Individual conductors must be insulated with PVC, PVC/nylon, vinyl, Teflon<sup>1</sup>, or polyethylene. An aluminum/polyester 100% foil shield and an outer jacket of PVC, PVC/nylon, chrome vinyl, or Teflon with a minimum operating temperature range of -20°C to 60°C is required. See table below for acceptable wiring.

MANUFACTURER	PART NO.
Alpha	2413 or 5463
Belden	8772
Carol	C2528
West Penn	302

It is important when connecting to a CCN communication bus that a color-coding scheme be used for the entire network to simplify the installation. It is recommended that red be used for the signal positive, black for the signal negative and white for the signal ground. Use a similar scheme for cables containing different colored wires.

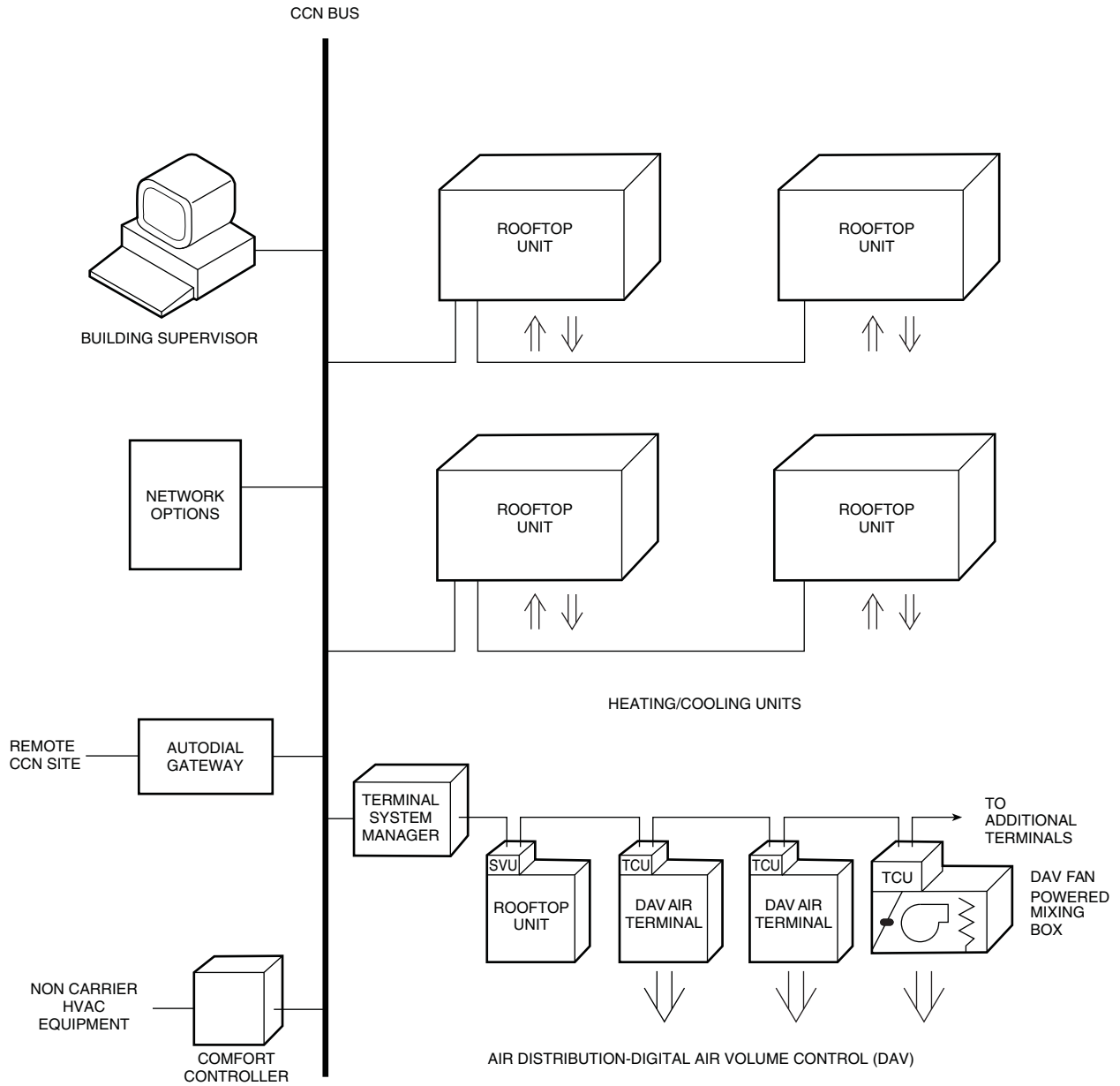
1. Teflon is a registered trademark of DuPont.

At each system element, the shields of its communication bus cables must be tied together. The shield screw on CIB can be used to tie the cables together. If the communication bus is entirely within one building, the resulting continuous shield must be connected to a ground at one point only. The shield screw on CIB is not acceptable for grounding. If the communication bus cable exits from one building and enters another, the shields must be connected to grounds at the lightning suppressor in each building where the cable enters or exits the building (one point per building only).

To connect the unit to the network:

1. Turn off power to the control box.
2. Cut the CCN wire and strip the ends of the red (+), white (ground), and black (-) conductors. (Substitute appropriate colors for different colored cables.)
3. Connect the red wire to (+) terminal on CIB, the white wire to COM terminal, and the black wire to the (-) terminal.
4. The RJ14 CCN connector on CIB can also be used, but is only intended for temporary connection (for example, a laptop computer running Carrier network software).
5. Restore power to unit.

**IMPORTANT:** A shorted CCN bus cable will prevent some routines from running and may prevent the unit from starting. If abnormal conditions occur, unplug the connector. If conditions return to normal, check the CCN connector and cable. Run new cable if necessary. A short in one section of the bus can cause problems with all system elements on the bus.



**LEGEND**

- CCN** — Carrier Comfort Network®
- DAV** — Digital Air Volume
- HVAC** — Heating, Ventilation, and Air Conditioning
- SVU** — SystemVu™ Controller
- TCU** — Terminal Control Unit

**Fig. 24 — CCN System Architecture**

## APPENDIX A — SYSTEMVU CONTROLLER DISPLAY

### RUN STATUS MAIN MENU LAYOUT

DISPLAY TEXT	EXPANDED DISPLAY TEXT	VALUES	UNITS	WRITE STATUS	POINT
SHUTDOWN UNIT?	Local Unit Shutdown Req.	Yes/No		Command	LOCSHUT
RUN STATUS	Run Status Menu				
MODE	Mode Status Menu				
MODE	Operating Mode	see Appendix B			MODETEXT
SUB-MODE	Operating Sub-Mode	see Appendix B			SUBMTEXT
DEMAND	System Demand	see Appendix B			SYS_DMDT
LINKAGE ACTIVE	Linkage Active	Yes/No			LNK_ACT
EFF COOL SETPOINT	Cool Setpoint In Effect	xx.x	°F		CSP_EFF
EFF HEAT SETPOINT	Heat Setpoint In Effect	xx.x	°F		HSP_EFF
DEMAND CTRL TEMP	Effective Demand Temp	xxx.x	°F		TEMP_EFF
OCC SPRH SETPOINT	Occupied SPRH Setpoint	xxx.x	%		SPRH_OSP
UNOCC SPRH SP	Unoccupied SPRH Setpoint	xxx.x	%		SPRH_USP
COOL MODE T.GUARD	Cool Mode Select T.guard	xxx	sec		COOLMSTG
HEAT MODE T.GUARD	Heat Mode Select T.guard	xxx	sec		HEATMSTG
COOLING DEMAND	Space Cooling Demand	xx.x	ΔF		COOL_DMD
COOL DEMAND TREND	Cooling Demand Trend	xx.x			CLDTREND
HEATING DEMAND	Heating Space Demand	xx.x	ΔF		HEAT_DMD
HEAT DEMAND TREND	Heat Space Demand Trend	xx.x			HTDTREND
DMD LIMIT STATUS	DEMAND LIMIT STATUS				
COOL DMD LIM OFF	Cool Demand Limiting	Yes/No			CDMLMOFF
HEAT DMD LIM OFF	Heat Demand Limiting	Yes/No			HDMLMOFF
COOL DMD LIM LEV	Cool demand Limit Level	0 to 3			CDMDLLEV
HEAT DMD LIM LEV	Heat demand Limit Level	0 to 3			HDMDLLEV
CL DMD LIM OFFSET	Cool Demand limit offset	xx.x	°F		COOLDLMO
HT DMD LIM OFFSET	Heat Demand limit offset	xx.x	°F		HEATDLMO
COOL	Cooling Status Menu				
COMMANDED IDF RPM	IDF CommanDED RPM	0 to 3000	RPM		FSPD_RPM
ACTIVE COOL STAGE	Actual Cool Stage Active	x			ACTCSTGS
ECON CMD POSITION	Econo CommanDED Position	0 to 100	%	Forcible	DAMPCMD
MECHANICAL COOLING	Mechanical Cooling Detail Sub-Menu				
OK TO MECH COOL	Ok to use compressors?	Yes/No			OKMECHCL
MECH COOL ACTIVE	Mechanical Cool active?	Yes/No			MECHCOOL
MAX COOL STAGES	Max Allowed Cool Stages	0 to 3		Forcible	MAXCSTGS
REQ. COOL STAGES	Requested Cooling Stages	0 to 3			REQCSTGS
ACTIVE COOL STAGE	Actual Cool Stage Active	x			ACTCSTGS
ODF STATE	ODF State	0=OFF, 1=ON, 2=LOW, 3=HIGH			ODFSTATE
COMP A1 TIMEGUARD	Compressor A1 Timeguard	xxx	sec		TIMGD_A1
CMP LDR TIMEGUARD	Comp A1 Loader Timeguard	xxx	sec		TIMG_ALD
SUPPLY AIR TREND	Supply Air Temp Trend	xxx.x			SATTREND
COMP A1 STRIKES	Compressor A1 strikes	x			A1STRIKE
RECENT A1 STRIKE	Recent Comp A1 Strike	Yes/No			A1STKACT
HI PRESS OVERRIDE	High Pressure Override	Yes/No			HP_OVR
CIRCUIT A LOCKOUT	Circuit A Locked Out	Yes/No			CIRALOCK
LOW COOL LOCKOUT	Low cooling locked out	Yes/No			LC_LOCK
COMP A1 AVAILABLE	Compressor A1 Available	Yes/No			CA1_AVAL
COMP A1 LOCKOUT	Compressor A1 Locked Out	Yes/No			CA1_LOCK
FREE COOLING	Free Cooling Detail Sub-menu				
OK TO FREE COOL	OK to Use Free Cooling?	Yes/No			OKFREECL
IN FREE COOLING	Free Cooling active	Yes/No			FREECOOL
FREECOOL SAT SP	Free Cooling SAT Setpnt	xx.x	°F		FC_SATSP
REQ. DAMPER POS	Requested Damper Pos	0 to 100	%		REQDAMP
ECON OPERATIONAL?	Econ Damper Operational	Yes/No			DAMPGOOD
DRY BULB LOCKOUT	Dry Bulb Lockout	Yes/No		Forcible	DBLOCK
ENTHALPY LOCKOUT	Enthalpy Lockout	Yes/No		Forcible	ENTHLOCK
OK TO UNOCC FC?	Ok to Unocc Free Cool?	Yes/No			OKTOUFC
IN UNOCC FREECOOL?	Unocc Free Cool Active	Yes/No			UFC_ACT
UFC LOCKOUT?	Unocc Free Cool Lockout	Yes/No			UNOCLOCK



**APPENDIX A — SYSTEMVU CONTROLLER DISPLAY**

**RUN STATUS MAIN MENU LAYOUT (CONT)**

DISPLAY TEXT	EXPANDED DISPLAY TEXT	VALUES	UNITS	WRITE STATUS	POINT
<b>COOL (cont)</b>	Cooling Status Menu				
<b>DEHUMIDIFICATION</b>	DEHUMIDIFICATION				
<b>OK TO DEHUM</b>	Ok to Dehumidify	Yes/No			OKTODHUM
<b>OK TO USE FBD</b>	Ok to use Fan Dehum	Yes/No			OKTOFBD
<b>FBD SST LOCK OUT</b>	FBDH SST Lockout	Yes/No			FBDSSTLO
<b>FBD SAT LOCK OUT</b>	FBDH SAT Lockout	Yes/No			FBDSATLO
<b>HEAT</b>	Heating Status Menu				
<b>COMMANDED IDF RPM</b>	IDF Commanded RPM	0 to 3000	RPM		FSPD_RPM
<b>ACTV HEAT SOURCE</b>	Active Type of Heat	0=NONE, 1=MECH ONLY, 2=MECH+1EH, 3=MECH+2EH, 4=ELCTHT1, 5=EH1+EH2, 6=DEFROST			HTSRCTYP
<b>ECON CMD POSITION</b>	Econo Commanded Position	0 to 100	%	Forcible	DAMPCMD
<b>HEAT LOCKOUT</b>	All Heat Stages Lockout	Yes/No		Forcible	ALLHTLOC
<b>DEFROST ACTIVE</b>	Defrost Mode Active	Yes/No			DFRSTACT
<b>OK TO USE HEAT</b>	OK to Run Heat	Yes/No			OKTOHEAT
<b>REQ. HEAT STAGES</b>	Requested Heating Stages	x			REQHSTGS
<b>ACTIVE HEAT STAGE</b>	Actual Heat Stage Active	x			ACTHSTGS
<b>MAX HEAT STAGES</b>	Max Allowed Heat Stages	x		Forcible	MAXHSTGS
<b>TIME IN DEFROST</b>	Defrost Mode Timer	xxxx	sec		DF_TIMER
<b>NEXT DEFROST IN</b>	Defrost Interval Timer	xxxx	sec		DFINT_T
<b>OK TO SA TEMPER</b>	OK to SupplyAirTempering	Yes/No			OKTOTEMP
<b>MECHANICAL HEATING</b>	Mechanical Heating Menu				
<b>MECH HEAT ACTIVE</b>	Mechanical Heating	Yes/No			MECHT_EN
<b>ODF STATE</b>	ODF State	0=OFF, 1=ON, 2=LOW, 3=HIGH			ODFSTATE
<b>COMP A1 TIMEGUARD</b>	Compressor A1 Timeguard	xxx	sec		TIMGD_A1
<b>CMP LDR TIMEGUARD</b>	Comp A1 Loader Timeguard	xxx	sec		TIMG_ALD
<b>SUPPLY AIR TREND</b>	Supply Air Temp Trend	xxx.x			SATTREND
<b>COMP A1 STRIKES</b>	Compressor A1 strikes	x			A1STRIKE
<b>RECENT A1 STRIKE</b>	Recent Comp A1 Strike	Yes/No			A1STKACT
<b>CIRCUIT A LOCKOUT</b>	Circuit A Locked Out	Yes/No			CIRALOCK
<b>COMP A1 AVAILABLE</b>	Compressor A1 Available	Yes/No			CA1_AVAL
<b>COMP A1 LOCKOUT</b>	Compressor A1 Locked Out	Yes/No			CA1_LOCK
<b>ELECTRIC HEATING</b>	Electric Heating Menu				
<b>HEAT 1 TIMEGUARD</b>	Heat Stage 1 Timeguard	xxx	sec		TIMGD_H1
<b>HEAT 2 TIMEGUARD</b>	Heat Stage 2 Timeguard	xxx	sec		TIMGD_H2
<b>DELAY FOR EHEAT2</b>	Heat2 delay timer	xxx	sec		H2DLTMR
<b>HEAT 1 AVAILABLE</b>	Heat Stage 1 Available	Yes/No			HT1_AVAL
<b>HEAT 2 AVAILABLE</b>	Heat Stage 2 Available	Yes/No			HT2_AVAL
<b>VENTILATION</b>	Ventilation Status Menu				
<b>VENT MODE</b>	Ventilation Status	see Appendix B			VENTTEXT
<b>EFFECTIVE MIN POS</b>	Min Position in Effect	0 to 100	%	Forcible	MIN_POS
<b>ECON ACT POSITION</b>	Damper Actual Position	0 to 100	%		DAMPPOS
<b>COMMANDED IDF RP</b>	IDF Commanded RPM	0 to 3000	RPM		FSPD_RPM
<b>OCCUPIED NOW</b>	Currently Occupied	Yes/No		Forcible	OCCUPIED
<b>IN PREOCC PURGE?</b>	In Pre-Occupancy Purge?	Yes/No			PREOCCON
<b>IN FREE COOLING</b>	Free Cooling active	Yes/No			FREECOOL
<b>DIFF AIR QUALITY</b>	Differential Air Quality	-5000 to 5000	PPM		AQ_DIFF
<b>OK TO PREOC PURGE</b>	Ok to Preoccupancy Purge	Yes/No			OKPREOCC
<b>IN IAQ OVERRIDE</b>	Is IAQ Override Active?	Yes/No			IAQ_OVRD
<b>DCV CURVE OFFSET</b>	IAQ DCV Curve Offset	0 to 100	%		IAQ_OFFS
<b>INDOOR FAN</b>	Indoor Fan Status Menu				
<b>COMMANDED IDF RPM</b>	IDF Commanded RPM	0 to 3000	RPM		FSPD_RPM
<b>IDF SPD OVERRIDE</b>	IDF Speed Override Flag	On/Off			FAN_OVRD
<b>FAULT ON ERROR</b>	Shut Down on IDF Failure	Yes/No		Configurable	FATALFAN
<b>IDF ERROR STATUS</b>	IDF Operation Errors?	Yes/No			IDFBAD

## APPENDIX A — SYSTEMVU CONTROLLER DISPLAY

### RUN STATUS MAIN MENU LAYOUT (CONT)

DISPLAY TEXT	EXPANDED DISPLAY TEXT	VALUES	UNITS	WRITE STATUS	POINT
<b>GENERAL</b>	General Run Data Menu				
<b>FILTER TIME LEFT</b>	Filter hour remaining	xxxx	hrs		FILTLEFT
<b>RESET FILTER TIME</b>	Reset Filter Timer	Yes/No		Command	RESETFLT
<b>IN DAYLIGHT SAVE?</b>	DST currently active	Yes/No			DST_ACTV
<b>TCS ACTIVE?</b>	Temp Compensate Start On	Yes/No			TCS_ACT
<b>OCCUPANCY</b>	OCCUPANCY DATA				
<b>OCCUPIED NOW</b>	Currently Occupied	Yes/No		Forcible	OCCUPIED
<b>MINS UNTIL OCC</b>	Mins until next occupied	x-1 to 10080	min		MINTILOC
<b>ACTIVE OCC CTRL</b>	Active Occupancy control	0=24/7 OCC, 1=SCHEDULE, 2=BAS CTRL, 3=REMOC CTL, 4=TIME OVRD, 5=LINKAGE, 6=FORCED			OCC_CTRL
<b>LINKAGE OCC REQ</b>	Linkage Occupied Request	0=Unocc, 1=Occupied, 2=Disabled		Forcible	LNK_OCC
<b>TIMED OVRD REMAIN</b>	Timed Override Remaining	0 to 240	min	Forcible	OVR_EXT
<b>REMOTE OCC SWITCH</b>	Remote Occupancy Switch	On/Off		Forcible	REMOCC
<b>BMS OCC REQUEST</b>	BMS Occupancy Request	0=UNOCC, 1=OCCUPIED, 2=DISABLED		Forcible	BMS_OCC
<b>LOCAL OCC REQUEST</b>	Local Sched Occ Request	0=Unocc, 1=Occupied		Forcible	LOC_OCC
<b>ACTIVE PERIOD</b>	Active Schedule period	0 to 8			PER_NO
<b>HOLIDAY TOMORROW?</b>	Tomorrow Is A Holiday	Yes/No			HOL_TMRW
<b>HOLIDAY TODAY?</b>	Today Is A Holiday	Yes/No			HOLTODAY
<b>NEXT OCC DAY</b>	Next Occupied Day	DDD			NXTOCDAY
<b>NEXT OCC TIME</b>	Next Occupied Time	hh:mm	min		NXTOCTIM
<b>NEXT UNOCC DAY</b>	Next Unoccupied Day	DDD			NXTUNDAY
<b>NEXT UNOCC TIME</b>	Next Unoccupied Time	hh:mm	min		NXTUNTIM
<b>PREV UNOCC DAY</b>	Previous Unoccupied Day	DDD			PRVUNDAY
<b>PREV UNOCC TIME</b>	Previous Unoccupied Time	hh:mm	min		PRVUNTIM

### SETTINGS MAIN MENU LAYOUT

DISPLAY TEXT	EXPANDED DISPLAY TEXT	VALUES	UNITS	DEFAULT	POINT
<b>SETTINGS</b>	SETTINGS MENU				
<b>SPACE SET POINTS</b>	Space Setpoints Adjustment Menu				
<b>OCC COOL SETPOINT</b>	Occupied Cool Setpoint	55 to 80	°F	78	OCCSP
<b>OCC HEAT SETPOINT</b>	Occupied Heat Setpoint	55 to 80	°F	68	OHSP
<b>UNOCC COOL SETPNT</b>	Unoccupied Cool Setpoint	65 to 95	°F	85	UCSP
<b>UNOCC HEAT SETPNT</b>	Unoccupied Heat Setpoint	40 to 80	°F	60	UHSP
<b>HEAT-COOL SP GAP</b>	Heat-Cool Setpoint Gap	2 to 10	°F	5	HCSP_GAP
<b>SPT SLIDER RANGE</b>	SPT Offset Range (+/-)	0 to 5	°F	5	SPTO_RNG
<b>OCC SPRH SETPOINT</b>	Occupied SPRH Setpoint	0 to 100	%	50	SPRH_OSP
<b>UNOCC SPRH SET PT</b>	Unoccupied SPRH Setpoint	0 to 100	%	80	SPRH_USP
<b>SPRH RH DEADBAND</b>	Space RH Deadband	2 to 20	%	8	SPRH_DB
<b>SA TEMPERING SP</b>	SA tempering Set point	30 to 80	°F	55	SATEMPSP
<b>TEMP DEMAND CONFIG</b>	Temperature Demand Configuration menu				
<b>LOW COOL DMD ON</b>	Low Cool Demand On	-1 to 2	°F	0.5	DMDLCON
<b>HIGH COOL DMD ON</b>	High Cool Demand On	0.5 to 20	°F	1.5	DMDHCON
<b>LOW COOL DMD OFF</b>	Low Cool Demand Off	-1 to 2	°F	-0.5	DMDLCOFF
<b>COOL DMD LEVEL UP</b>	Cool Demand Level Up	-2 to 2	°F	-0.2	CDMD_LUP
<b>LOW HEAT DMD ON</b>	Low Heat Demand On	-1 to 2	°F	0.5	DMDLHON
<b>HIGH HEAT DMD ON</b>	High Heat Demand On	0.5 to 20	°F	2	DMDHHON
<b>LOW HEAT DMD OFF</b>	Low Heat Demand Off	-1 to 2	°F	-0.5	DMDLHOFF
<b>HEAT DMD LEVEL UP</b>	Heat Demand Level Up	-2 to 2	°F	-0.2	HDMDLUP
<b>DEMAND TIMEGUARD1</b>	Space Demand Time Guard1	60 to 600	sec	120	TDMD_TG1
<b>DEMAND TIMEGUARD2</b>	Space Demand Time Guard2	0 to 600	sec	240	TDMD_TG2
<b>DEMAND TIMEGUARD3</b>	Space Demand Time Guard3	5 to 120	min	10	TDMD_TG3

## APPENDIX A — SYSTEMVU CONTROLLER DISPLAY

### SETTINGS MAIN MENU LAYOUT (CONT)

DISPLAY TEXT	EXPANDED DISPLAY TEXT	VALUES	UNITS	DEFAULT	POINT
<b>DMD LIMIT CONFIG</b>	DEMAND LIMIT CONFIG				
<b>COOL DMD LIM LEV1</b>	COOL DMD Offset level 1	0 to 99	°F	1	CLDOLEV1
<b>COOL DMD LIM LEV2</b>	COOL DMD Offset level 2	0 to 99	°F	3	CLDOLEV2
<b>COOL DMD LIM LEV3</b>	COOL DMD Offset level 3	0 to 99	°F	5	CLDOLEV3
<b>HEAT DMD LIM LEV1</b>	Heat DMD Offset level 1	0 to 99	°F	1	HTDOLEV1
<b>HEAT DMD LIM LEV2</b>	Heat DMD Offset level 2	0 to 99	°F	3	HTDOLEV2
<b>HEAT DMD LIM LEV3</b>	Heat DMD Offset level 3	0 to 99	°F	5	HTDOLEV3
<b>CLOCK</b>	CLOCK ADJUSTMENT MENU				
<b>TIME</b>	Clock Hour and Minute	xx:xx	hh.mm		TIME
<b>DATE</b>	Current Date	MM/DD/YYYY			DATE
<b>DAYLIGHT SAVINGS</b>	Daylight Savings Configuration Menu				
<b>DAYLIGHT SAVINGS?</b>	DST allowed?	Enable/Disable		1	DST_CFG
<b>DST START MONTH</b>	DST Start Month	1=JANUARY, 2=FEBRUARY, 3=MARCH, 4=APRIL, 5=MAY, 6=JUNE, 7=JULY, 8=AUGUST, 9=SEPTEMBER, 10=OCTOBER, 11=NOVEMBER, 12=DECEMBER		3	STARTM
<b>DST START WEEK</b>	DST Start Week	1 to 5		2	STARTW
<b>DST START DAY</b>	DST Start Day	1=MONDAY, 2=TUESDAY, 3=WEDNESDAY, 4=THURSDAY, 5=FRIDAY, 6=SATURDAY, 7=SUNDAY		7	STARTD
<b>DST MINS TO ADD</b>	DST Minutes to Add	0 to 90	min	60	MINADD
<b>DST STOP MONTH</b>	DST Stop Month	1=JANUARY, 2=FEBRUARY, 3=MARCH, 4=APRIL, 5=MAY, 6=JUNE, 7=JULY, 8=AUGUST, 9=SEPTEMBER, 10=OCTOBER, 11=NOVEMBER, 12=DECEMBER		11	STOPM
<b>DST STOP WEEK</b>	DST Stop Week	1 to 5		1	STOPW
<b>DST STOP DAY</b>	DST Stop Day	1=MONDAY, 2=TUESDAY, 3=WEDNESDAY, 4=THURSDAY, 5=FRIDAY, 6=SATURDAY, 7=SUNDAY		7	STOPD
<b>DST MINS TO SUB</b>	DST Minutes to Subtract	0 to 90	min	60	MINSUB
<b>START TIME IN DAY</b>	Time in day to start DST	0 to 600	min	120	DST_TOD
<b>SCHEDULES</b>	SCHEDULES ADJUSTMENT MENU				
<b>SCHEDULE NUMBER</b>	CCN Schedule Number	0 = Always Occupied, 1-64 = Local Schedule, 65-99 = Global Schedule		0 = Always Occupied	SCHEDNUM
<b>OCCUPANCY SCHEDULE</b>	OCCUPANCY SCHEDULE DATA				
<b>Holiday adjustment Menu</b>	Holiday adjustment Menu				
<b>ALLOW G. HOLIDAY?</b>	Accept Global Holidays?	Yes/No		No	HOLIDAYT
<b>TIMED OVR LENGTH</b>	Timed Override Duration	0 to 4	hrs	4	OTL_CFG
<b>CAN CANCEL T.OVR</b>	Allow SPT Ovrld Cancel	Yes/No		No	CLROVCFG

## APPENDIX A — SYSTEMVU CONTROLLER DISPLAYS

### SETTINGS MAIN MENU LAYOUT (CONT)

DISPLAY TEXT	EXPANDED DISPLAY TEXT	VALUES	UNITS	DEFAULT	POINT
<b>UNIT CONFIGURATIONS</b>	UNIT CONFIGURATIONS MENU				
<b>GENERAL</b>	General Unit Configurations Menu				
<b>STARTUP DELAY</b>	Unit Startup Delay	10 to 600	sec	30	STARTDLY
<b>UNIT CONTROL TYPE</b>	Unit Control Type	0=TSTAT, 1=SPACE SEN, 2=RAT SEN		0=TSTAT	CTRLTYPE
<b>THERMOSTAT TYPE</b>	Thermostat Hardware Type	0=CONV 2C2H, 1=DIGI 2C2H, 2=CONV 3C2H, 3=DIGI 3C2H		0=CONV 2C2H	STATTYPE
<b>VENT METHOD</b>	Ventilation Method	0=NONE, 1=ECON, 2=2POS DMPR, 3=ERV, 4=ECON ERV		0: No FIOP 1: Economizer FIOP 2: Two Position Damper FIOP	VENTTYPE
<b>2POS/ERV CHANNEL</b>	2-Pos Damper/ERV Channel	0=NONE, 1=MBB RLY11, 2=MBB RLY06		0: No FIOP 2: FIOP	EV2PCHAN
<b>ADAPTIVE TSTAT</b>	Tstat Adaptive Staging	Yes/No		Yes	ADPTSTAT
<b>DIRTY FILTER TIME</b>	Change Filter Timer	0 to 9999	hrs	0	FILT LIFE
<b>TEST MODE TIMEOUT</b>	Test inactivity time out	0=Disabled, 1=30 minutes, 2=1 hour, 3=2 hours, 4=4 hours, 5=8 hours, 6=12 hours		4	TEST_ITO
<b>CCH MAX TEMP</b>	CCH Max Temperature	40 to 90	°F	65	CCHMAXT
<b>STD BARO PRESSURE</b>	Std Barometric Pressure	13 to 35	Hg	29.92	STD_BARP
<b>LINK STAGEUP TIME</b>	Linkage Stage inc. time	60 to 600	sec	180	LSTAGINC
<b>UNIT'S MAX SAT</b>	Unit's Maximum SAT	130 to 210	°F	200	UMAX_SAT
<b>UNIT'S MIN SAT</b>	Unit's Minimum SAT	30 to 70	°F	32	UMIN_SAT
<b>AUTO SAT FAULTS?</b>	Auto Clr SAT Limit Fault	Yes/No		Yes	SATLACLR
<b>SA FREEZE PROTECT</b>	SAT Freeze Protection	Enable/Disable		Enable	SATFZPRO
<b>ADAPTIVE TCS?</b>	Adaptive Temp Comp Start	Enable/Disable		Enable	TCS_CFG
<b>USER TCS BIASTIME</b>	User TCS Start Bias Time	0 to 180	min	0	TCSUBIAS
<b>SWITCH INPUTS CONFIGS</b>	DI Config Menu				
<b>FIRE SW CHANNEL</b>	Fire Switch Channel	0=None, 1=MBB DI12, 2=MBB DI13, 3=MBB DI14, 4=MBB DI02, 5=MBB DI03, 6=MBB Y3		0: No FIOP 5: FIOP	FIRECHAN
<b>FIRE SHUTDOWN SW</b>	Fire Shutdown Sw Type	0=NORM OPEN, 1=NORM CLSD		0=NORM OPEN	FIRE_CFG
<b>HUMSTAT CHANNEL</b>	Humidistat Status Chan.	0=None, 1=MBB DI12, 2=MBB DI13, 3=MBB DI14, 4=MBB DI02, 5=MBB DI03, 6=MBB Y3		0=None	HUMDCHAN
<b>HUMSTAT SW TYPE</b>	Humidistat Switch Type	0=NORM OPEN, 1=NORM CLSD		0=NORM OPEN	HUMD_CFG
<b>FILTER SW CHANNEL</b>	Filter Status Sw Channel	0=None, 1=MBB DI12, 2=MBB DI13, 3=MBB DI14, 4=MBB DI02, 5=MBB DI03, 6=MBB Y3		0: No FIOP 1: FIOP	FILTCHAN
<b>FILTER SW TYPE</b>	Filter Status Sw Type	0=NORM OPEN, 1=NORM CLSD		0=NORM OPEN	FILT_CFG
<b>REMOTE OCC CHAN</b>	Remote Occupancy Channel	0=None, 1=MBB DI12, 2=MBB DI13, 3=MBB DI14, 4=MBB DI02, 5=MBB DI03, 6=MBB Y3		0=None	RMOCCHAN
<b>REMOTE OCC TYPE</b>	Remote Occupancy Sw Type	0=NORM OPEN, 1=NORM CLSD		0=NORM OPEN	RMOC_CFG

## APPENDIX A — SYSTEMVU CONTROLLER DISPLAYS

### SETTINGS MAIN MENU LAYOUT (CONT)

DISPLAY TEXT	EXPANDED DISPLAY TEXT	VALUES	UNITS	DEFAULT	POINT
<b>SWITCH INPUTS CONFIGS (cont)</b>	DI Config Menu				
<b>REM.SHUTDOWN CHAN</b>	Remote Shutdown Channel	0=None, 1=MBB DI12, 2=MBB DI13, 3=MBB DI14, 4=MBB DI02, 5=MBB DI03, 6=MBB Y3		0=None	ROFFCHAN
<b>REM.SHUTDOWN SW T</b>	Remote Shutdown SW Type	0=NORM OPEN, 1=NORM CLSD		0=NORM OPEN	ROFF_CFG
<b>REM.SHUTDOWN TYPE</b>	Remote Shutdown ALM Type	0=Normal, 1=Emergency		0=Normal	ROFFTYPE
<b>COFS CHANNEL</b>	COFS Assigned Channel	0=None, 1=MBB DI12, 2=MBB DI13, 3=MBB DI14, 4=MBB DI02, 5=MBB DI03, 6=MBB Y3		0: No FIOP 4: FIOP	COFSCHAN
<b>COFS TYPE</b>	COFS Switch Type	0=NORM OPEN, 1=NORM CLSD		1=NORM CLSD	COFS_CFG
<b>GEN STATUS CHAN</b>	General Status Channel	0=None, 1=MBB DI12, 2=MBB DI13, 3=MBB DI14, 4=MBB DI02, 5=MBB DI03, 6=MBB Y3		0=None	GEN_CHAN
<b>GEN STAT SW TYPE</b>	General Status Sw Type	0=NORM OPEN, 1=NORM CLSD		0=NORM OPEN	GENS_CFG
<b>SHUTDOWN GEN STAT</b>	General Status shutdown?	Yes/No		Yes	GENFATAL
<b>ENTHALPY SW CHAN</b>	Enthalpy Sw Channel	0=None, 1=MBB DI12, 2=MBB DI13, 3=MBB DI14, 4=MBB DI02, 5=MBB DI03, 6=MBB Y3		0=NONE	ENTHCHAN
<b>ENTHALPY SW TYPE</b>	Enthalpy Switch Type	0=NORM OPEN, 1=NORM CLSD		0=NORM OPEN	ENTH_CFG
<b>FAN STAT CHANNEL</b>	Fan Status Channel	0=None, 1=MBB DI12, 2=MBB DI13, 3=MBB DI14, 4=MBB DI02, 5=MBB DI03, 6=MBB Y3		0=NONE	FNSTCHAN
<b>FAN STAT SW CFG</b>	Fan Status SW Type	0=NORM OPEN, 1=NORM CLSD		0=NORM OPEN	FANSTICFG
<b>IAQ OVERRIDE SW CH</b>	IAQ override sw channel	0=None, 1=MBB DI12, 2=MBB DI13, 3=MBB DI14, 4=MBB DI02, 5=MBB DI03, 6=MBB Y3		0=NONE	IAQOCHAN
<b>IAQ OVRRD SW TYPE</b>	IAQ Override Switch Type	0=NORM OPEN, 1=NORM CLSD		0=NORM OPEN	IAQOSCFG
<b>PHASE MON CHANNEL</b>	Phase Monitor Channel	0=None, 1=MBB DI12, 2=MBB DI13, 3=MBB DI14, 4=MBB DI02, 5=MBB DI03, 6=MBB Y3		0: No FIOP 3: FIOP	PMR_CHAN
<b>PHASE MON SW TYPE</b>	Phase Monitor SW Type	0=NORM OPEN, 1=NORM CLSD		1=NORM CLSD	PMR_CFG
<b>SMOKE PURGE CHAN</b>	Smoke Purge Sw Channel	0=None, 1=MBB DI12, 2=MBB DI13, 3=MBB DI14, 4=MBB DI02, 5=MBB DI03, 6=MBB Y3		0=NONE	PURGCHAN

## APPENDIX A — SYSTEMVU CONTROLLER DISPLAYS

### SETTINGS MAIN MENU LAYOUT (CONT)

DISPLAY TEXT	EXPANDED DISPLAY TEXT	VALUES	UNITS	DEFAULT	POINT
<b>SWITCH INPUTS CONFIGS</b> (cont)	DI Config Menu				
<b>SMOKE PURGE TYPE</b>	Smoke Purge Switch Type	0=NORM OPEN, 1=NORM CLSD		0=NORM OPEN, 1=NORM CLSD	PURG_CFG
<b>SMOKE PRESS CHAN</b>	Smoke Pressure Sw Chan	0=None, 1=MBB DI12, 2=MBB DI13, 3=MBB DI14, 4=MBB DI02, 5=MBB DI03, 6=MBB Y3		0=NONE	PRESCHAN
<b>SMOKE PRESS TYPE</b>	Smoke Pressure Sw Type	0=NORM OPEN, 1=NORM CLSD		0=NORM OPEN	PRES_CFG
<b>SMOKE EVAC CHAN</b>	Smoke Evacuation Sw Chan	0=None, 1=MBB DI12, 2=MBB DI13, 3=MBB DI14, 4=MBB DI02, 5=MBB DI03, 6=MBB Y3		0=NONE	EVACCHAN
<b>SMOKE EVAC TYPE</b>	Smoke Evacuation Sw Type	0=NORM OPEN, 1=NORM CLSD		0=NORM OPEN	EVAC_CFG
<b>ANALOG INPUT CONFIGS</b>	Analog Inputs Configuration Menu				
<b>SPRH SENS CHANNEL</b>	SPRH Assigned Channel	0=None, 1=MBB AI06, 2=MBB AI07, 3=MBB AI08		0=NONE	SPRHCHAN
<b>SPRH RH @ 4MA</b>	SPRH Sensor Value at 4mA	0 to 100	%	0	SPRH_4MA
<b>SPRH RH @ 20MA</b>	SPRH Sensor Value @ 20mA	0 to 100	%	100	SPRH20MA
<b>IAQ SENSOR CHAN</b>	IAQ Assigned Channel	0=None, 1=MBB AI06, 2=MBB AI07, 3=MBB AI08		0: No FIOP 2:FIOP	IAQ_CHAN
<b>IAQ PPM @ 4MA</b>	IAQ Sensor Value at 4mA	0 to 5000	PPM	0	IAQ_4MA
<b>IAQ PPM @ 20MA</b>	IAQ Sensor Value at 20mA	0 to 5000	PPM	2000	IAQ_20MA
<b>OAQ SENSOR CHAN</b>	OAQ Assigned Channel	0=None, 1=MBB AI06, 2=MBB AI07, 3=MBB AI08		0=NONE	OAQ_CHAN
<b>OAQ PPM @ 4MA</b>	OAQ Sensor Value at 4mA	0 to 5000	PPM	0	OAQ_4MA
<b>OAQ PPM @ 20MA</b>	OAQ Sensor Value at 20mA	0 to 5000	PPM	2000	OAQ_20MA
<b>OARH SENSOR CHAN</b>	OARH Assigned Channel	0=None, 1=MBB AI06, 2=MBB AI07, 3=MBB AI08		0: No FIOP 3: FIOP	OARHCHAN
<b>OARH RH @ 4MA</b>	OARH Sensor Value at 4mA	0 to 100	%	0	OARH_4MA
<b>OARH RH @ 20MA</b>	OARH Sensor Val. at 20mA	0 to 100	%	100	OARH20MA
<b>RARH SENS CHANNEL</b>	RARH Assigned Channel	0=None, 1=MBB AI06, 2=MBB AI07, 3=MBB AI08		0=NONE	RARHCHAN
<b>RARH RH @ 4MA</b>	RARH Sensor Value at 4mA	0 to 100	%	0	RARH_4MA
<b>RARH RH @ 20MA</b>	RARH Sensor Value @ 20mA	0 to 100	%	100	RARH20MA
<b>OACFM SENSOR CHAN</b>	OACFM Assigned Channel	0=None, 1=MBB AI06, 2=MBB AI07, 3=MBB AI08		0=NONE	OACFMCHAN
<b>OACFM @ 4MA</b>	OACFM value at 4MA	0 to 2000	CFM	0	OACFM_4MA
<b>OACFM @ 20MA</b>	OACFM Value @ 20mA	2000 to 5000	CFM	2000	OACFM20MA
<b>COOLING</b>	Cooling Configurations Menu				
<b>COOL STAGEUP TIME</b>	Cool Stage Increase Time	120 to 999	sec	450	CSTAGINC
<b>COOL SATTREND LEV</b>	Cooling SAT Trend Level	-1 to 1		-0.2	SAT_TLC
<b>UPPER MIN SAT</b>	Cool Min SAT Upper Level	35.0 to 65.0	°F	56	SATMIN_H
<b>LOWER MIN SAT</b>	Cool Min SAT Lower Level	35.0 to 65.0	°F	46	SATMIN_L
<b>COOL FANOFF DELAY</b>	Cooling Fan-Off Delay	0 to 600	sec	60	COOL_FOD
<b>ODF HIGH SPD TIME</b>	ODF High Speed Time	0 to 300	sec	120	MINODFTM

## APPENDIX A — SYSTEMVU CONTROLLER DISPLAYS

### SETTINGS MAIN MENU LAYOUT (CONT)

DISPLAY TEXT	EXPANDED DISPLAY TEXT	VALUES	UNITS	DEFAULT	POINT
<b>FAN BASED DEHUM</b>	Fan Based Dehum CFG Menu				
<b>FBD CONTROL TYPE</b>	Fan Based Dehum Type	0=NONE, 1=Comfort, 2=Max		0=NONE	FBD_TYPE
<b>FBD COOL DELTA</b>	FBDH Low Set Point	-20 to 0	ΔF	-2.5	FBDLO_SP
<b>FBD MAX SST SP</b>	FBDH Max Mode SST SP	20 to 60	°F	38	FBDSSSTSP
<b>FBD SST MIN VALUE</b>	FBDH Min SST Threshold	10 to 60	°F	32	FBDH_SST
<b>FBD CMFT SAT SP</b>	FBDH Comfort SAT SP	35 to 80	°F	46	FBDH_SAT
<b>FBD CMFT SAT DT</b>	FBD Comfort SAT Delta	0 to 30	°F	11	FBDSATDT
<b>FBD MIN FAN SPD</b>	FBDH Min Fan Speed	0 to 3000	RPM	same as IDF LOW COOL SPD (see Page 64)	FDRPMMIN
<b>FBD MAX FAN SPD</b>	FBDH Max Fan Speed	0 to 3000	RPM	same as IDF HIGH COOL SPD (See page 64)	FDRPMMAX
<b>LOW AMBIENT</b>	LOW AMBIENT CONFIGS MENU				
<b>NO LOW CHARGE OAT</b>	Low Charge Disable Temp	-40 to 50	°F	10	LOCH_LOT
<b>LOW COOL MIN OAT</b>	Low Cool lockout Temp	-20 to 60	°F	10	LCLOCKSP
<b>HEATING</b>	Heating Configurations Menu				
<b>TIME BTWN DEFROST</b>	Min Time BTWN Defrosts	30 to 120	min	60	MINDFINT
<b>MAX DEFROST TIME</b>	Defrost Max Duration	5 to 25	min	10	MAXDFTMR
<b>HEAT STAGEUP TIME</b>	Heat Stage Increase Time	120 to 999	sec	450	HSTAGINC
<b>HEAT SATTREND LEV</b>	Heating SAT Trend Level	-1 to 1		0.2	SAT_TLH
<b>LOWER MAX SAT</b>	Heat Max SAT Lower Level	85 to 200	°F	140	SATMAX_L
<b>UPPER MAX SAT</b>	Heat Max SAT Upper Level	85 to 200	°F	170	SATMAX_H
<b>HEAT FANOFF DELAY</b>	Heating Fan-Off Delay	10 to 600	sec	60	HEAT_FOD
<b>HEAT LOCKOUT OAT</b>	Heating Lockout Temp	40 to 125	°F	75	OATLHEAT
<b>MEC HEATLOCK TEMP</b>	Mech Heat Lockout Temp	-30 to 40	°F	-8	OATLMECH
<b>LLSV ON TIME</b>	LiquidLine Valve On Time	0 to 300	sec	60	LLSV_CT
<b>SAT DURING HEAT?</b>	SAT heat mode sensing	Enable/Disable		Enable	SAT_HEAT
<b>SA TEMPER ENABLED</b>	Supply Air Temper Enable	Yes/No		No	SATEMPEN
<b>SA TEMPERING SP</b>	SA tempering Set point	35 to 80	°F	55	SATEMPSP
<b>TEMPER MAX OAT</b>	Max OAT for SA tempering	40 to 80	°F	65	OATSTEMP
<b>START DEFROST DLY</b>	Startup Defrost Delay	0 to 120	min	5	DFHLD_T
<b>ELECTRIC HEAT</b>	Electric Heat Setting Menu				
<b>HEATING STAGE QTY</b>	Number Of Heating Stages	0 to 3		1	NUMHSTGS
<b>MAX OAT FOR 3STGS</b>	Max OAT for 3 Heat Stags	0 to 90	°F	20	HT2LCTMP
<b>HEAT MIN ON</b>	Heat Minimum On Time	60 to 600	sec	120	H_MINON
<b>HEAT MIN OFF</b>	Heat Minimum Off Time	60 to 600	sec	120	H_MINOFF
<b>PREHEAT W/O IDF?</b>	Pre-Heat HX without IDF?	Enable/Disable		Disable	PREHT_HX
<b>PREHEAT FAN DELAY</b>	Pre-Heat Fan On Delay	0 to 120	sec	30	PREHT_TM
<b>COMPRESSOR DIAG</b>	COMPRESSOR DIAGNOSTIC MENU				
<b>COMP MIN ON TIME</b>	Compressor Min On Time	180 to 600	sec	300	C_MINON
<b>COMP MIN OFF TIME</b>	Compressor Min Off Time	120 to 600	sec	180	C_MINOFF
<b>STRIKE CLEAR TIME</b>	Runtime to Reset Strikes	120 to 999	sec	300	MIN_ON_S
<b>CHARGE DIAGNOSTICS</b>	Refrigerant Charge Diagnostic Config Menu				
<b>LOW CHARGE LEVEL</b>	Low Refrig Charge Level	0 to 150	PSI	50	LOCHARGE
<b>NO LOW CHARGE OAT</b>	Low Charge Disable Temp	-40 to 50	°F	10	LOCH_LOT
<b>CIR.A SDP LIMIT</b>	CirA High Pressure Limit	400 to 700	PSI	670	HIPLIM_A
<b>LOW DISCHARGE LEV</b>	Low Discharge Level	0 to 20	°F	0	SDTLEV
<b>LOW DISCHRG DIAG</b>	Low Discharge Diagnostic	Enable/Disable		Disable	DISLDPAL
<b>MIN PRESS RATIO</b>	Minimum Pressure Ratio	0 to 5		1.35	MINPSI_R
<b>LOW SUCTION DIAG.</b>	Low Suction Diagnostic Config Menu				
<b>LOW SUC OK TEMP</b>	Suction OK Temperature	10 to 50	°F	18	SSTOK
<b>LOW SUC LEVEL 1</b>	Low Suction Level 1 Temp	10 to 50	°F	20	SSTLEV1
<b>LOW SUC LEVEL 2</b>	Low Suction Level 2 Temp	5 to 50	°F	15	SSTLEV2
<b>LOW SUC LEVEL 3</b>	Low Suction Level 3 Temp	0 to 50	°F	10	SSTLEV3
<b>LO SUC DIAG DELAY</b>	Delay On Low SST Check	0 to 300	sec	0	SSTCKDLY
<b>HEAT LO SUC OFFST</b>	Heat Low Suc Lvl Offset	0 to 100	°F	30	SSTOFSET
<b>COMPRESSOR TRANSITION</b>	Compressor Transition diagnostic config menu				
<b>COMP L2 DIAG DLY</b>	Comp Level 2 Diag Delay	1 to 300	sec	15	CDDTLEV2
<b>DIAG. COMP OFF</b>	Diag Comp Unexpected Off	Enable/Disable		Enable	CD_UEOFF

## APPENDIX A — SYSTEMVU CONTROLLER DISPLAYS

### SETTINGS MAIN MENU LAYOUT (CONT)

DISPLAY TEXT	EXPANDED DISPLAY TEXT	VALUES	UNITS	DEFAULT	POINT
<b>COMPRESSOR TRANSITION (cont)</b>	Compressor Transition diagnostic config menu				
<b>CIR STUCK ON DIAG</b>	Circuit Stuck On Diag.	Enable/Disable		Enable	DCKTOFF
<b>CIR.A MIN DIS.P</b>	Min discharge change	0 to 99	PSI	8	MDP_DISA
<b>CIR.A MIN SUC.P</b>	Min Suction change	0 to 99	PSI	10	MDP_SUCA
<b>OFF P.RATIO</b>	CirA P.Ratio off change	-1 to 1		-0.3	OFFPR_A
<b>DEFROST UEOFF DLY</b>	Comp UEOFF Diag Delay	0 to 300	sec	30	ACAOFF_T
<b>INDOOR FAN</b>	Indoor Fan Configurations Menu				
<b>OCCUPIED FAN?</b>	Fan On When Occupied	Yes/No		Yes	FANON_OC
<b>IDF MAX SPEED</b>	IDF Maximum Fan Speed	0 to 100	%	100	SPEEDMAX
<b>IDF VENT SPD</b>	IDF Vent Speed-RPM	0 to 3000	RPM	same as IDF LOW COOL SPD (see Page 64)	RPM_VENT
<b>IDF HEAT SPD</b>	IDF Heat Speed-RPM	0 to 3000	RPM	same as IDF HIGH COOL SPD (See page 64)	RPM_HEAT
<b>IDF LOW COOL SPD</b>	IDF Low Cool Speed-RPM	0 to 3000	RPM	1106: Size 04 Standard Static Fan 1281: Size 04 Medium Static Fan 1457: Size 04 High Static Fan 1112: Size 05 Standard Static Fan 1269: Size 05 Medium Static Fan 1439: Size 05 High Static Fan 230v 1 ph 1556: Size 05 High Static Fan 230v 3ph, 460v, 575v 1258: Size 06 Standard Static Fan 1398: Size 06 Medium Static Fan 1556: Size 06 High Static Fan 230v 1 ph 1659: Size 06 High Static Fan 230v 3ph, 460v, 575v 1184: Size 07 Standard Static Fan 1302: Size 07 Medium Static Fan 1460: Size 07 High Static Fan	RPM_LCL
<b>IDF HIGH COOL SPD</b>	IDF High Cool Speed-RPM	0 to 3000	RPM	1474: Size 04 Standard Static Fan 1708: Size 04 Medium Static Fan 1942: Size 04 High Static Fan 1482: Size 05 Standard Static Fan 1693: Size 05 Medium Static Fan 1919: Size 05 High Static Fan 230v 1 ph 2075: Size 05 High Static Fan 230v 3ph, 460v, 575v 1677: Size 06 Standard Static Fan 1864: Size 06 Medium Static Fan 2075: Size 06 High Static Fan 230v 1 ph 2212: Size 06 High Static Fan 230v 3ph, 460v, 575v 1794: Size 07 Standard Static Fan 1973: Size 07 Medium Static Fan 2212: Size 07 High Static Fan	RPM_HCL
<b>IDF FREE COOL SPD</b>	IDF Free Cool Speed-RPM	0 to 3000	RPM	same as IDF LOW COOL SPD (see Page 64)	RPM_FCL
<b>FAULT ON ERROR</b>	Shut Down on IDF Failure	Yes/No		Yes	FATALFAN



## APPENDIX A — SYSTEMVU CONTROLLER DISPLAYS

### SETTINGS MAIN MENU LAYOUT (CONT)

DISPLAY TEXT	EXPANDED DISPLAY TEXT	VALUES	UNITS	DEFAULT	POINT
<b>ECONOMIZER</b>	Economizer Configurations Menu				
<b>VENT METHOD</b>	Ventilation Method	0=NONE, 1=ECON, 2=2POS DMPR, 3=ERV, 4=ECON ERV		0: No FIOP 1: Economizer FIOP 2: Two Position Damper FIOP	VENTTYPE
<b>ECON MAX POS</b>	Econ Max Damper Position	0 to 100	%	100	DAMPMAX
<b>ECON TRAVEL TIME</b>	Economizer Travel Time	5 to 300	sec	150	ECONOTRV
<b>MINIMUM POSITION CONFIGS</b>	Minimum Position Configurations menu				
<b>MIN POS @ MAX FAN</b>	Econ Min at Max Fanspeed	0 to 100	%	30	MINP_MAX
<b>MIN POS SPEED 1</b>	Min Pos - User Speed 1	0 to 100	%	0	MP_USPD1
<b>MIN POS DAMP 1</b>	Min Pos - User Pos 1	0 to 100	%	0	MP_UPOS1
<b>MIN POS SPEED 2</b>	Min Pos - User Speed 2	0 to 100	%	0	MP_USPD2
<b>MIN POS DAMP 2</b>	Min Pos - User Pos 2	0 to 100	%	0	MP_UPOS2
<b>MIN POS SPEED 3</b>	Min Pos - User Speed 3	0 to 100	%	0	MP_USPD3
<b>MIN POS DAMP 3</b>	Min Pos - User Pos 3	0 to 100	%	0	MP_UPOS3
<b>FREE COOL CONFIGS</b>	Free Cooling Specific Configurations Menu				
<b>LOW COOL SAT SP</b>	LowFree Cool SAT Setpnt	40 to 80	°F	65	LCSASP
<b>HIGH COOL SAT SP</b>	High FreeCool SAT Setpnt	40 to 80	°F	55	HCSASP
<b>FREE COOL MAX OAT</b>	Free Cooling Max OAT	0 to 90	°F	65	MAXFREET
<b>FREE COOL MIN OAT</b>	Free Cooling Min Temp	-30 to 70	°F	0	MINFREET
<b>DIFF DRY BULB CTL</b>	Diff. Dry Bulb Control	Enable/Disable		Disable	DIFFBULB
<b>DIFF DB DEADBAND</b>	Diff. Dry Bulb Deadband	0 to 20	°F	3	OATRATDB
<b>ENTHALPY HI LIMIT</b>	Max Enthalpy OA limit	1 to 99	BTU/LB	28	FREEMAXE
<b>DIFF ENTHALPY CTL</b>	Diff. Enthalpy Control	Enable/Disable		Disable	DIFFENTH
<b>ENTHALPY DEADBAND</b>	Enthalpy Cross Deadband	0 to 20	BTU/LB	2	OAERAEDB
<b>UNOCCUPIED FREE COOL</b>	Unoccupied Free Cooling Configs Menu				
<b>WHEN TO UNOCC FC</b>	When to Unocc Free Cool?	0=Disabled, 1=PreOcc, 2=Unocc		1=PreOcc	UFC_CFG
<b>UFC PREOCC TIME</b>	UFC PreOcc Time	1 to 999	min	120	UFCTIME
<b>UFC LOW TEMP</b>	Unocc Free Cool Low Temp	-30 to 70	°F	50	OATLUFC
<b>POWER EXHAUST CONFIGS</b>	Power Exhaust Configurations Menu				
<b>PE1 RELAY CHANNEL</b>	PE1 Relay Channel	0=NONE, 1=MBB RLY11, 2=MBB RLY06		0: no FIOP 2: FIOP	PE1_CHAN
<b>PE1 POS @ MAX SPD</b>	PE Stage 1 at Max speed	0 to 100	%	40	PE1_PMAX
<b>PE OFF DEADBAND</b>	PE Turn Off Dead band	0 to 100	%	5	PE_OFFDB
<b>PE2 RELAY CHANNEL</b>	PE2 Relay Channel	0=NONE, 1=MBB RLY11, 2=MBB RLY06		0=NONE	PE2_CHAN
<b>PE2 POS @ MAX SPD</b>	PE Stage 2 At Max Speed	0 to 100	%	75	PE2_PMAX
<b>ECON ACT MECH DISC DIAG</b>	Econ Actuator Mechanical disconnect diagnostic menu				
<b>MDD-H/C END DLY</b>	T24 Heat/Cool End Delay	0 to 60	min	25	T24CHDLY
<b>MDD-MIN MOVE</b>	T24Econ Min Move for SAT	10 to 20	%	10	T24ECSTS
<b>MDD-SAT DB</b>	Damper SAT deadband	0 to 20	°F	12	T24SATDB
<b>MDD-MIN RAT-OAT</b>	T24 Min Diff in RAT-OAT	5 to 20	°F	15	T24RATDF
<b>MDD-MIN TEST POS</b>	T24 Test Minimum Pos	0 to 100	%	15	T24STMN
<b>MDD-MAX TEST POS</b>	T24 Test Maximum Pos	0 to 100	%	85	T24STMX
<b>AIR QUALITY</b>	Air Quality Configurations Menu				
<b>ANALOG IAQ CTRL</b>	Analog Input IAQ Control	0=NO IAQ, 1=DCV, 2=IAQ OVRD, 3=CTRL MINP		0: no FIOP 1: FIOP	IAQANCFG
<b>IAQ POS @ MAX SPD</b>	IAQ Position at Max Fan	0 to 100	%	10	IAQMNP
<b>LOW AIR.Q DIFF</b>	AQ Differential Low	0 to 5000		100	DAQ_LOW
<b>HGH AIR.Q DIFF</b>	AQ Differential High	0 to 5000		700	DAQ_HIGH
<b>PREOCC PURGE ENBL</b>	IAQ Preoccupancy Purge	Yes/No		Yes	IAQPURGE
<b>PURGE POS @ MAX</b>	IAQ Purge Pos at Max IDF	0 to 100	%	40	IAQPMAX
<b>PREOCC LOW LIMIT</b>	Preocc Purge Lockout OAT	0 to 70	°F	50	IAQP_LA
<b>PREOCC PURGE TIME</b>	Preocc Purge Duration	5 to 120	min	15	IAQPTIME

## APPENDIX A — SYSTEMVU CONTROLLER DISPLAYS

### SETTINGS MAIN MENU LAYOUT (CONT)

DISPLAY TEXT	EXPANDED DISPLAY TEXT	VALUES	UNITS	DEFAULT	POINT
<b>AIR QUALITY (cont)</b>	Air Quality Configurations Menu				
<b>AQ DIF HI-IAQ OVR</b>	AQ Diff High IAQOVERRIDE	0 to 5000	PPM	700	AQD_HIGH
<b>AQ DIF LO-IAQ OVR</b>	AQ Diff Low-IAQ OVERRIDE	0 to 5000	PPM	100	AQD_LOW
<b>IAQ OVRRD ENABLE</b>	IAQ override enable	Yes/No		No	IAQOVREN
<b>SW IAQ FAN CTRL</b>	Switch Input IAQ Fan ctl	0=Never, 1=Occupied, 2=Always		0=Never	IAQSWFAN
<b>AI IAQ FAN CTRL</b>	Analog Input IAQ Fan ctl	0=Never, 1=Occupied, 2=Always		0=Never	IAQANFAN
<b>AQ OVR POSITION</b>	IAQ Override Position	0 to 100	%	100	IAQOVPOS
<b>ALARM RELAY</b>	Alarm Relay Configurations Menu				
<b>ALM RELAY CHANNEL</b>	ALM Relay Assigned Chan	0=NONE, 1=MBB RLY11, 2=MBB RLY06		1=MBB RLY11	ALM_CHAN
<b>THERMOSTAT ALERTS</b>	Thermostat Alerts	Yes/No		Yes	TSTAT_AL
<b>HARDWARE ALERTS</b>	Hardware Failures Alerts	Yes/No		Yes	HW_AL
<b>SAT/RAT ALERTS</b>	SAT/RAT Sensor Alerts	Yes/No		Yes	SATRATAL
<b>OAT SENSOR ALERTS</b>	OAT Thermistor Alerts	Yes/No		Yes	OATRL_AL
<b>SPACE SENS ALERTS</b>	Space Sensors Alerts	Yes/No		Yes	SPACE_AL
<b>TRANSDUCER ALERTS</b>	Transducer Sensor Alerts	Yes/No		Yes	TRANS_AL
<b>RH SENSOR ALERTS</b>	RH sensor failure Alert	Yes/No		Yes	RHS_AL
<b>CO2 SENSOR ALERTS</b>	Air Quality CO2 Alerts	Yes/No		Yes	CO2S_AL
<b>OACFM SENS ALERTS</b>	OACFM Alarm Relay	Yes/No		No	OACFM_AL
<b>ECONOMIZER ALERTS</b>	Economizer Alerts	Yes/No		Yes	ECON_AL
<b>AIR FILTER ALERTS</b>	Dirty Filter Alerts	Yes/No		Yes	FILT_AL
<b>GEN STATUS ALERTS</b>	General Status Alerts	Yes/No		Yes	GENS_AL
<b>REFRIG CIR ALERTS</b>	Refrig Circuit Alerts	Yes/No		Yes	CKT_AL
<b>COMPRESSOR ALERTS</b>	Compressor Alerts	Yes/No		Yes	COMP_AL
<b>HEATING ALERTS</b>	Heating Failure Alerts	Yes/No		Yes	HEAT_AL
<b>INDOOR FAN ALERTS</b>	Indoor Fan Alerts	Yes/No		Yes	FAN_AL
<b>ON ACTIVE FAULTS</b>	Relay On Active Faults	Yes/No		Yes	FAULT_AL
<b>SERVICE CONFIG MENU</b>	Service Configuration Menu				
<b>CMP FRAMEWORK</b>	Compressor Framework	0=1CIR 2CMP, 1=1CMP+LDR, 2=1CMP		1: All except below 2: 50FCQ 04-06	SYSVTYPE
<b>ODF RELAY ENABLE</b>	ODF Relay Enabled	Yes/No		No: 50FCQ Yes: 50GCQ	OFR_EN
<b>SHUTDWN A1 FIRST</b>	Comp A1 Shutdown First	Yes/No		No	SDWN_A1
<b>SHUTDWN ALD FIRST</b>	Comp Loader Shutdown 1st	Yes/No		Yes: All except below No: 50FCQ 04-06	SDWN_ALD
<b>IDF CURVE LO RPM</b>	IDF Curve Low End RPM	0 to 3000	RPM	189: Size 04 Standard Static Fan 219: Size 04 Medium Static Fan 249: Size 04 High Static Fan 190: Size 05 Standard Static Fan 217: Size 05 Medium Static Fan 246: Size 05 High Static Fan 230v 1 ph 266: Size 05 High Static Fan 230v 3ph, 460v, 575v 215: Size 06 Standard Static Fan 239: Size 06 Medium Static Fan 266: Size 06 High Static Fan 230v 1 ph 284: Size 06 High Static Fan 230v 3ph, 460v, 575v 230: Size 07 Standard Static Fan 253: Size 07 Medium Static Fan 284: Size 07 High Static Fan	IFMLORPM

## APPENDIX A — SYSTEMVU CONTROLLER DISPLAYS

### SETTINGS MAIN MENU LAYOUT (CONT)

DISPLAY TEXT	EXPANDED DISPLAY TEXT	VALUES	UNITS	DEFAULT	POINT
<b>SERVICE CONFIG MENU</b> (cont)	Service Configuration Menu				
<b>IDF CURVE HI RPM</b>	IDF Curve High End RPM	0 to 3000	RPM	1890: Size 04 Standard Static Fan 2190: Size 04 Medium Static Fan 2490: Size 04 High Static Fan 1900: Size 05 Standard Static Fan 2170: Size 05 Medium Static Fan 2460: Size 05 High Static Fan 230v 1 ph 2660: Size 05 High Static Fan 230v 3ph, 460v, 575v 2150: Size 06 Standard Static Fan 2390: Size 06 Medium Static Fan 2660: Size 06 High Static Fan 230v 1 ph 2836: Size 06 High Static Fan 230v 3ph, 460v, 575v 2300: Size 07 Standard Static Fan 2530: Size 07 Medium Static Fan 2836: Size 07 High Static Fan	IFMHIRPM
<b>CCH RELAY1 ENABLE</b>	CCH Relay 1 Enabled	Yes/No		Yes	CCHR1_EN
<b>ECONO PID - KP</b>	ECONO PID - KP	0.00 to 99.90		2.5	ECONO_P
<b>ECONO PID - KI</b>	ECONO PID - KI	0.00 to 99.90		0.12	ECONO_I
<b>ECONO PID - KD</b>	ECONO PID - KD	0.00 to 99.90		1	ECONO_D
<b>ECONO PID - RATE</b>	ECONO PID - RATE	10 to 180	sec	15	ECONO_DT
<b>FBD PID - KP</b>	FBD PID - Kp	0 to 99.99		0.01	FBDPID_P
<b>FBD PID - KI</b>	FBD PID Ki	0 to 99.999		0	FBDPID_I
<b>FBD PID - KD</b>	FBD PID Kd	0 to 99.999		0	FBDPID_D
<b>FBD KI RES VAL</b>	FBD Ki Reset Val.	0.00 to 99.90		0	FBDKIRES
<b>NEW HARDWARE</b>	Quick Menu for New Hardware				
<b>UNIT CONTROL TYPE</b>	Unit Control Type	0=TSTAT, 1=SPACE SEN, 2=RAT SEN		0=TSTAT	CTRLTYPE
<b>VENT METHOD</b>	Ventilation Method	0=NONE, 1=ECON, 2=2POS DMPR, 3=ERV, 4=ECON ERV		0: No FIOP 1: Economizer FIOP 2: Two Position Damper FIOP	VENTTYPE
<b>SPRH SENS CHANNEL</b>	SPRH Assigned Channel	0=None, 1=MBB A106, 2=MBB A107, 3=MBB A108		0=NONE	SPRHCHAN
<b>IAQ SENSOR CHAN</b>	IAQ Assigned Channel	0=None, 1=MBB A106, 2=MBB A107, 3=MBB A108		0: no FIOP 2: FIOP	IAQ_CHAN
<b>OAQ SENSOR CHAN</b>	OAQ Assigned Channel	0=None, 1=MBB A106, 2=MBB A107, 3=MBB A108		0=NONE	OAQ_CHAN
<b>OARH SENSOR CHAN</b>	OARH Assigned Channel	0=None, 1=MBB A106, 2=MBB A107, 3=MBB A108		0: no FIOP 3: FIOP	OARHCHAN
<b>RARH SENS CHANNEL</b>	RARH Assigned Channel	0=None, 1=MBB A106, 2=MBB A107, 3=MBB A108		0=NONE	RARHCHAN
<b>OACFM SENS CHANNEL</b>	OACFM Assigned Channel	0=None, 1=MBB A106, 2=MBB A107, 3=MBB A108, 4=SIOB A110		0=NONE	OACFMCHAN

## APPENDIX A — SYSTEMVU CONTROLLER DISPLAYS

### SETTINGS MAIN MENU LAYOUT (CONT)

DISPLAY TEXT	EXPANDED DISPLAY TEXT	VALUES	UNITS	DEFAULT	POINT
<b>NEW HARDWARE (cont)</b>	Quick Menu for New Hardware				
<b>FIRE SW CHANNEL</b>	Fire Switch Channel	0=None, 1=MBB DI12, 2=MBB DI13, 3=MBB DI14, 4=MBB DI02, 5=MBB DI03, 6=MBB Y3		0: No FIOP 5: FIOP	FIRECHAN
<b>HUMSTAT CHANNEL</b>	Humidistat Status Chan.	0=None, 1=MBB DI12, 2=MBB DI13, 3=MBB DI14, 4=MBB DI02, 5=MBB DI03, 6=MBB Y3		0=NONE	HUMDCHAN
<b>FILTER SW CHANNEL</b>	Filter Status Sw Channel	0=None, 1=MBB DI12, 2=MBB DI13, 3=MBB DI14, 4=MBB DI02, 5=MBB DI03, 6=MBB Y3		0: No FIOP 1: FIOP	FILTCHAN
<b>REMOTE OCC CHAN</b>	Remote Occupancy Channel	0=None, 1=MBB DI12, 2=MBB DI13, 3=MBB DI14, 4=MBB DI02, 5=MBB DI03, 6=MBB Y3		0=NONE	RMOCCCHAN
<b>REM.SHUTDOWN CHAN</b>	Remote Shutdown Channel	0=None, 1=MBB DI12, 2=MBB DI13, 3=MBB DI14, 4=MBB DI02, 5=MBB DI03, 6=MBB Y3		0=NONE	ROFFCHAN
<b>COFS CHANNEL</b>	COFS Assigned Channel	0=None, 1=MBB DI12, 2=MBB DI13, 3=MBB DI14, 4=MBB DI02, 5=MBB DI03, 6=MBB Y3		0: No FIOP 4: FIOP	COFSCHAN
<b>GEN STATUS CHAN</b>	General Status Channel	0=None, 1=MBB DI12, 2=MBB DI13, 3=MBB DI14, 4=MBB DI02, 5=MBB DI03, 6=MBB Y3		0=NONE	GEN_CHAN
<b>ENTHALPY SW CHAN</b>	Enthalpy Sw Channel	0=None, 1=MBB DI12, 2=MBB DI13, 3=MBB DI14, 4=MBB DI02, 5=MBB DI03, 6=MBB Y3		0=NONE	ENTHCHAN
<b>FAN STAT CHANNEL</b>	Fan Status Channel	0=None, 1=MBB DI12, 2=MBB DI13, 3=MBB DI14, 4=MBB DI02, 5=MBB DI03, 6=MBB Y3		0=NONE	FNSTCHAN
<b>IAQ OVERRIDE SW CH</b>	IAQ override sw channel	0=None, 1=MBB DI12, 2=MBB DI13, 3=MBB DI14, 4=MBB DI02, 5=MBB DI03, 6=MBB Y3		0=NONE	IAQOCHAN
<b>PHASE MON CHANNEL</b>	Phase Monitor Channel	0=None, 1=MBB DI12, 2=MBB DI13, 3=MBB DI14, 4=MBB DI02, 5=MBB DI03, 6=MBB Y3		0: No FIOP 3: FIOP	PMR_CHAN

## APPENDIX A — SYSTEMVU CONTROLLER DISPLAYS

### SETTINGS MAIN MENU LAYOUT (CONT)

DISPLAY TEXT	EXPANDED DISPLAY TEXT	VALUES	UNITS	DEFAULT	POINT
<b>NEW HARDWARE (cont)</b>	Quick Menu for New Hardware				
<b>SMOKE PURGE CHAN</b>	Smoke Purge Sw Channel	0=None, 1=MBB DI12, 2=MBB DI13, 3=MBB DI14, 4=MBB DI02, 5=MBB DI03, 6=MBB Y3		0=NONE	PURGCHAN
<b>SMOKE PRESS CHAN</b>	Smoke Pressure Sw Chan	0=None, 1=MBB DI12, 2=MBB DI13, 3=MBB DI14, 4=MBB DI02, 5=MBB DI03, 6=MBB Y3		0=NONE	PRESCHAN
<b>SMOKE EVAC CHAN</b>	Smoke Evacuation Sw Chan	0=None, 1=MBB DI12, 2=MBB DI13, 3=MBB DI14, 4=MBB DI02, 5=MBB DI03, 6=MBB Y3		0=NONE	EVACCHAN
<b>NETWORK SETTINGS</b>	Building Network Configurations Menu				
<b>BAS PROTOCOL</b>	BAS Protocol Select	0=NONE, 1=CCN, 2=BACNET		0=NONE	BMS_CFG
<b>NETWORK TIMEOUT</b>	Network Input Timeout	0 to 600	min	30	NETINTO
<b>CCN</b>	CCN Network Configuration Menu				
<b>BUS NUMBER</b>	CCN Bus Number	0 to 239		0	CCNBUS
<b>CCN ELEMENT #</b>	CCN Element Number	1 to 239		1	CCNADD
<b>CCN BAUDRATE</b>	CCN Baud Rate	0=9600, 1=19200, 2=38400		2=38400	BAUDENUM
<b>BROADCAST ACK?</b>	CCN Broadcast Ack'er	Yes/No		No	CCNBCACK
<b>BROADCAST SCHEDL?</b>	Global Schedule Broadcst	Yes/No		No	CCN_GSBC
<b>BROADCAST TIME?</b>	CCN Time Broadcast	Yes/No		No	CCNBC
<b>BROADCAST OAT?</b>	Broadcast OAT On Network	Yes/No		No	OATBC
<b>BROADCAST OARH?</b>	Broadcast OARH On Netwrk	Yes/No		No	OARHBC
<b>BROADCAST OAQ?</b>	Broadcast OAQ On Network	Yes/No		No	OAQBC
<b>BROADCAST IAQ?</b>	Broadcast IAQ On Network	Yes/No		No	IAQBC
<b>ALLOW G. OVERRIDE</b>	Allow Global Overrides	Yes/No		Yes	GLBLOVER
<b>LOCATION</b>	Device Location	text			DEV_LOC
<b>REFERENCE NUMBER</b>	Reference number	text			REF_NUM
<b>BACNET</b>	BACnet network configuration menu				
<b>MAC ADDRESS</b>	BACnet Device Macaddress	1 to 127		01	BAC_MAC
<b>BACNET BAUDRATE</b>	BACnet BMS baud rate	0=9600, 1=19200, 2=38400, 3=57600, 4=76800, 5=115200		4=76800	BAC_BAUD
<b>AUTO ID SCHEME</b>	ALC Auto Id Scheme	Yes/No		Yes	AUID
<b>BACNET AUTO ID</b>	BACnet ID Auto ID	Yes/No		Yes	BAC_AUID
<b>BACNET ID</b>	BACnet ID Number	0 to 4194302		1610101	BAC_ID
<b>LINKAGE SETTINGS</b>	LINKAGE SETTINGS MENU				
<b>DEVICE IAQ</b>	BACnet device for IAQ	0 to 4194303		1610100	DEVIAQ
<b>OBJECT ID IAQ</b>	Object instance for IAQ	0 to 9999		1009	OBJIAQ
<b>COV IAQ</b>	Change of value for IAQ	0 to 60		0	COVIAQ
<b>DEVICE OAQ</b>	BACnet device for OAQ	0 to 4194303		1610100	DEVOAQ
<b>OBJECT ID OAQ</b>	Object instance for OAQ	0 to 9999		1012	OBJOAQ
<b>COV OAQ</b>	Change of value for OAQ	0 to 60		0	COVOAQ
<b>DEVICE OARH</b>	BACnet device for OARH	0 to 4194303		1610100	DEVOARH
<b>OBJECT ID OARH</b>	Object instance for OARH	0 to 9999		1022	OBJOARH
<b>COV OARH</b>	Change of value for OARH	0 to 60		0	COVOARH
<b>DEVICE OAT</b>	BACnet device for OAT	0 to 4194303		1610100	DEVOAT
<b>OBJECT ID OAT</b>	Object instance for OAT	0 to 9999		1003	OBJOAT

## APPENDIX A — SYSTEMVU CONTROLLER DISPLAYS

### SETTINGS MAIN MENU LAYOUT (CONT)

DISPLAY TEXT	EXPANDED DISPLAY TEXT	VALUES	UNITS	DEFAULT	POINT
<b>BACNET (cont)</b>	BACnet network configuration menu				
<b>COV OAT</b>	Change of value for OAT	0 to 60		0	COVOAT
<b>DEVICE RARH</b>	BACnet device for RARH	0 to 4194303		1610100	DEVRRARH
<b>OBJECT ID RARH</b>	Object instance for RARH	0 to 9999		30	OBJRRARH
<b>COV RARH</b>	Change of value for RARH	0 to 60		0	COVRARH
<b>DEVICE RAT</b>	BACnet device for RAT	0 to 4194303		1610100	DEVRRAT
<b>DBJECT ID RAT</b>	Object instance for RAT	0 to 9999		1010	OBJRRAT
<b>COV RAT</b>	Change of value for RAT	0 to 60		0	COVRAT
<b>DEVICE SPT</b>	BACnet device for SPT	0 to 4194303		1610100	DEVSPT
<b>OBJECT ID SPT</b>	Object instance for SPT	0 to 9999		2007	OBJSPT
<b>COV SPT</b>	Change of value for SPT	0 to 60		0	COVSPT
<b>LOCAL_SHEDL_EDIT</b>	Allow Local Sched Edit	Yes/No	enum	No	LCL_EDIT
<b>SYSTEM TOUCH</b>	System Touch Menu				
<b>DEVICE INSTANCE</b>	System Touch Device Inst	0 to 4194303		160099	DEVST
<b>POLLING RATE</b>	System Touch Poll Rate	10 to 60		10	POLLST
<b>SPACE TEMP AI</b>	System Touch AI for SPT	0 to 9999		1	AISTSPT
<b>SPACE RH AI</b>	System Touch AI for SPRH	0 to 9999		4	AISTSPRH
<b>ZS SENSOR CFG</b>	ZS Sensor Configuration				
<b>ZS1 ADDRESS</b>	Zone Sensor 1 Address	0 to 255		255	ZSADDR1
<b>ZS2 ADDRESS</b>	Zone Sensor 2 Address	0 to 255		255	ZSADDR2
<b>ZS3 ADDRESS</b>	Zone sensor 3 address	0 to 255		255	ZSADDR3
<b>ZS4 ADDRESS</b>	Zone sensor 4 address	0 to 255		255	ZSADDR4
<b>ZS5 ADDRESS</b>	Zone sensor 5 address	0 to 255		255	ZSADDR5
<b>ZS POLL RATE</b>	Zone sensor poll rate	1 to 100	sec	5	ZSPOLLRT
<b>ZS UNIT</b>	Zone sensor unit	0=degrees F		0=degrees F	ZSUNIT
<b>ZS FRC UNOC ENBL</b>	ZS Force Unoccup enable	Yes/No		No	ZSFUNEN
<b>ZS FRC UNOC DELAY</b>	ZS Force unocc wt delay	Yes/No		No	ZSFUNWT
<b>ZS TLO CONT ENBL</b>	ZS TLO Cont Enable	Yes/No		No	ZSTLOEN
<b>TLO SET DURING OC</b>	ZS TLO set during occ	Yes/No		No	ZSTLSOC
<b>ZS UI MODE</b>	Zone sensor UI Mode	1=Dual Offsets		1=Dual Offsets	ZSUIM
<b>NETWORK CHKLIST</b>	NETWORK SETUP CHECKLIST	0=Undone, 1=Perfom, 2=Done		0=Undone	CHK_NET
<b>DISPLAY SETTINGS</b>	User Display Configurations Menu				
<b>METRIC DISPLAY</b>	Metric Display	Yes/No		No	DISPUNIT
<b>LANGUAGE</b>	Display Language Select	0=English, 1=Spanish,		0=English	LANGUAGE
<b>CONTRAST ADJUST</b>	LCD Contrast Adjustment	1 to 10		5	LCD_CONT
<b>PASSWORD ENABLE?</b>	User Password Protection	Enable/Disable		Enable	PASS_EBL
<b>VIEW USER PASSWORD</b>	View User Password Menu				
<b>CHANGE USER PASSWORD</b>	Change User Password Menu				
<b>QUICK SETUP CONFIG</b>	QUICK SETUP CONFIG MENU				
<b>TIME</b>	Clock Hour and Minute	xx:xx			TIME
<b>DATE</b>	Current Date	MM/DD/YYYY			DATE
<b>STARTUP DELAY</b>	Unit Startup Delay	10 to 600	sec	30	STARTDLY
<b>UNIT CONTROL TYPE</b>	Unit Control Type	0=TSTAT, 1=SPACE SEN, 2=RAT SEN		0=TSTAT	CTRLTYPE
<b>THERMOSTAT TYPE</b>	Thermostat Hardware Type	0=CONV 2C2H, 1=DIGI 2C2H, 2=CONV 3C2H, 3=DIGI 3C2H		0=CONV 2C2	STATTYPE
<b>DIRTY FILTER TIME</b>	Change Filter Timer	0 to 9999	hrs	0	FILTIFE
<b>QUICK SETUP CONFIG</b>	QUICK SETUP CONFIG MENU				
<b>TIME BTWN DEFROST</b>	Min Time BTWN Defrosts	30 to 120	min	60	MINDFINT
<b>HEATING STAGE QTY</b>	Number of Heating Stages	0 to 2		1	NUMHSTGS
<b>VENT METHOD</b>	Ventilation Method	0=NONE, 1=ECON, 2=2POS DMPR, 3=ERV, 4=ECON ERV		0: No FIOP 1: Economizer FIOP 2: Two Position Damper FIOP	VENTTYPE
<b>FREE COOL MAX OAT</b>	Free Cooling Max OAT	0 to 90	°F	65	MAXFREET

## APPENDIX A — SYSTEMVU CONTROLLER DISPLAYS

### SETTINGS MAIN MENU LAYOUT (CONT)

DISPLAY TEXT	EXPANDED DISPLAY TEXT	VALUES	UNITS	DEFAULT	POINT
<b>QUICK SETUP CONFIG</b>	QUICK SETUP CONFIG MENU				
<b>FIRE SW CHANNEL</b>	Fire Switch Channel	0=None, 1=MBB DI12, 2=MBB DI13, 3=MBB DI14, 4=MBB DI02, 5=MBB DI03, 6=MBB Y3		0: No FIOP 5: FIOP	FIRECHAN
<b>IDF LOW COOL SPD</b>	IDF Low Cool Speed-RPM	0 to 3000	RPM	1106: Size 04 Standard Static Fan 1281: Size 04 Medium Static Fan 1457: Size 04 High Static Fan 1112: Size 05 Standard Static Fan 1269: Size 05 Medium Static Fan 1439: Size 05 High Static Fan 230v 1 ph 1556: Size 05 High Static Fan 230v 3ph, 460v, 575v 1258: Size 06 Standard Static Fan 1398: Size 06 Medium Static Fan 1556: Size 06 High Static Fan 230v 1 ph 1659: Size 06 High Static Fan 230v 3ph, 460v, 575v 1184: Size 07 Standard Static Fan 1302: Size 07 Medium Static Fan 1460: Size 07 High Static Fan	RPM_LCL
<b>IDF HIGH COOL SPD</b>	IDF High Cool Speed-RPM	0 to 3000	RPM	1474: Size 04 Standard Static Fan 1708: Size 04 Medium Static Fan 1942: Size 04 High Static Fan 1482: Size 05 Standard Static Fan 1693: Size 05 Medium Static Fan 1919: Size 05 High Static Fan 230v 1 ph 2075: Size 05 High Static Fan 230v 3ph, 460v, 575v 1677: Size 06 Standard Static Fan 1864: Size 06 Medium Static Fan 2075: Size 06 High Static Fan 230v 1 ph 2212: Size 06 High Static Fan 230v 3ph, 460v, 575v 1794: Size 07 Standard Static Fan 1973: Size 07 Medium Static Fan 2212: Size 07 High Static Fan	RPM_HCL
<b>IDF VENT SPD</b>	IDF Vent Speed-RPM	0 to 3000	RPM	same as IDF LOW COOLSPD	RPM_VENT
<b>IDF HEAT SPD</b>	IDF Heat Speed-RPM	0 to 3000	RPM	same as IDF HIGH COOL SPD	RPM_HEAT
<b>QUICK SET CHKLIST</b>	QUICK SETUP CHECKLIST	0=Undone, 1=Perform, 2=Done		0=Undone	CHK_QUIK

### ALERTS/FAULTS MAIN MENU LAYOUT

DISPLAY TEXT	EXPANDED DISPLAY TEXT	VALUES	WRITE STATUS	POINT
<b>ALERTS/FAULTS</b>	Alerts/Faults Menu			
<b>ACTIVE FAULTS</b>	Active Faults Menu			
<b>ACTIVE ALERTS</b>	Active Alerts Menu			
<b>HISTORY</b>	History Of Faults And Alerts Menu			
<b>RESET FAULT/ALERT</b>	Reset All Current Alarms	Yes/No	Command	ALRESET

## APPENDIX A — SYSTEMVU CONTROLLER DISPLAYS

### SERVICE MAIN MENU LAYOUT

DISPLAY TEXT	EXPANDED DISPLAY TEXT	VALUES	UNITS	WRITE STATUS	POINT
<b>SERVICE</b>	Service Menu				
<b>UNIT TESTS</b>	Unit Tests Menu				
<b>TEST MODE</b>	Service Test Mode Enable	On/Off		Command	
<b>SERVICE TEST</b>	Service Test Menu				
<b>INDEPENDENTS</b>	INDEPENDENT TEST MENU				
<b>ECON POS TEST</b>	Economizer Position Test	0 to 100	%	Command	S_DAMPER
<b>BUMP COMP A1 TEST</b>	Compressor Bump A1 Test	On/Off		Command	S_BMPA1
<b>REV VALVE SOL TST</b>	Rev.Val. Sole. Cir.A Tst	On/Off		Command	S_RVS_A
<b>LLSV RELAY TEST</b>	LiqLine Solenoid Test	On/Off		Command	S_LLSV
<b>CCH RELAY 1 TEST</b>	Crankcase Heater 1 test	On/Off		Command	S_CCHR1
<b>ALARM RELAY TEST</b>	Alarm Output Relay Test	On/Off		Command	S_ALARM
<b>PE1 RELAY TEST</b>	Power Exhaust 1 Test	On/Off		Command	S_PE_1
<b>PE2 RELAY TEST</b>	Power Exhaust 2 Test	On/Off		Command	S_PE_2
<b>2POS/ERV RLY TEST</b>	2Position/ERV Relay Test	On/Off		Command	S_ERV2P
<b>DAMPER CALIBRATION</b>	Damper Calibration Menu				
<b>DAMPER CALIBRATE</b>	Econ Damper Calibration	On/Off		Command	S_ECOCAL
<b>FAN TESTS</b>	Indoor and Outdoor Fan tests Menu				
<b>IDF SPEED TEST</b>	Indoor Fan Speed Test	0 to 100	%	Command	S_IDFSPD
<b>CONVERTED IDF RPM</b>	Converted IDF Speed	0 to 5000	RPM		IFRPMTST
<b>IDF MANUAL TRANS</b>	IDF Manual Transition	Yes/No		Command	S_IDFTRN
<b>ODF ON/OFF TEST</b>	ODF On/Off Relay Test	On/Off		Command	S_ODFON
<b>ODF RELAY TEST</b>	ODF Speed Relay Test	On/Off		Command	S_OFRSPD
<b>COOL TESTS</b>	Cooling Test Menu				
<b>COOL A1 TEST</b>	Cooling W/Comp.A1 Test	On/Off		Command	S_COOLA1
<b>CIR A LOADER TEST</b>	Cooling W/Comp.ALD Test	On/Off		Command	S_COLALD
<b>IDF SPEED TEST</b>	Indoor Fan Speed Test	0 to 100	%	Command	S_IDFSPD
<b>ODF ON/OFF TEST</b>	ODF On/Off Relay Test	On/Off		Command	S_ODFON
<b>ODF RELAY TEST</b>	ODF Speed Relay Test	On/Off		Command	S_OFRSPD
<b>HEAT TESTS</b>	Heating Test Menu				
<b>MECH HEAT TEST</b>	Mechanical Heating Test	On/Off		Command	S_MECHT
<b>HEAT 1 TEST</b>	Heating Stage 1 Test	On/Off		Command	S_HEAT1
<b>HEAT 2 TEST</b>	Heating Stage 2 Test	On/Off		Command	S_HEAT2
<b>IDF SPEED TEST</b>	Indoor Fan Speed Test	0 to 100	%	Command	S_IDFSPD
<b>DEFROST TEST</b>	Defrost Test	On/Off		Command	S_DFRST
<b>AUTOMATIC TEST</b>	Automatic Test Menu				
<b>AUTO INDP TEST</b>	AUTO INDEPENDENT TEST	Yes/No		Command	AUTOINDP
<b>AUTO COOL TEST</b>	RUN AUTO COOLING TEST	Yes/No		Command	AUTOCOOL
<b>AUTO HEAT TEST</b>	RUN AUTO HEATING TEST	Yes/No		Command	AUTOHEAT
<b>AUTO SYSTEM TEST</b>	RUN AUTO SYSTEM TEST	Yes/No		Command	AUTOSYS
<b>UNIT INFORMATION</b>	Unit Information Menu				
<b>MODEL #</b>	Equipment Model number	xxxxxxxxxxxxxxxxxxxx		Command	EQ_MOD
<b>SERIAL #</b>	Equipment Serial number	xxxxxxxxxx		Command	EQ_SER
<b>VERSIONS</b>	Versions Menu				
<b>MAIN APP</b>	Application SW Version	CESR131690-01-xx			FW_CESR
<b>BOOTLOADER</b>	Bootloader SW Version	CESR131659-01-xx			BL_CESR
<b>USER MEASURED DATA</b>	User Measured Data Menu				
<b>SUPPLY VOLTAGE L1</b>	Supply Voltage Leg 1	0 to 700	V	Command	L1VOLTS
<b>SUPPLY VOLTAGE L2</b>	Supply Voltage Leg 2	0 to 700	V	Command	L2VOLTS
<b>SUPPLY VOLTAGE L3</b>	Supply Voltage Leg 3	0 to 700	V	Command	L3VOLTS
<b>COMP A1 AMPS L1</b>	Comp A1 Amps Leg 1	0 to 100	A	Command	CA1L1_A
<b>COMP A1 AMPS L2</b>	Comp A1 Amps Leg 2	0 to 100	A	Command	CA1L2_A
<b>COMP A1 AMPS L3</b>	Comp A1 Amps Leg 3	0 to 100	A	Command	CA1L3_A
<b>E.HEAT AMPS L1</b>	Elec. Heat Amps Leg 1	0 to 100	A	Command	EHTL1_A
<b>E.HEAT AMPS L2</b>	Elec. Heat Amps Leg 2	0 to 100	A	Command	EHTL2_A
<b>E.HEAT AMPS L3</b>	Elec. Heat Amps Leg 3	0 to 100	A	Command	EHTL3_A
<b>CONTINUE?</b>	Start Diag Report	Yes/No		Command	GO_DIAG



## APPENDIX A — SYSTEMVU CONTROLLER DISPLAYS

### SERVICE MAIN MENU LAYOUT (CONT)

DISPLAY TEXT	EXPANDED DISPLAY TEXT	VALUES	UNITS	WRITE STATUS	POINT
<b>UNIT INFORMATION (cont)</b>	Unit Information Menu				
<b>RUN HOURS &amp; CYCLES</b>	Run Hours & Cycles Menu				
<b>RUN HOURS DATA MENU</b>	Run hours menu				
<b>2POS/ERV RUN HOUR</b>	2Position/ERV Run Hours	xxxxxx.x	hrs		HR_ERV2P
<b>COMP A1 RUN HOURS</b>	Compressor A1 Run Hours	xxxxxx.x	hrs		HR_A1
<b>CMP ALD RUN HOURS</b>	CMP A1 Loader Run Hours	xxxxxx.x	hrs		HR_ALDR
<b>ALM RELAY HOURS</b>	Alarm Relay Run Hours	xxxxxx.x	hrs		HR_ALM
<b>CCH RELAY HOURS</b>	CCH1 Relay Run Hours	xxxxxx.x	hrs		HR_CCHR1
<b>ECON RUN HOURS</b>	Econ Damper Run Hours	xxxxxx.x	hrs		HR_DAMP
<b>DEFROST HOURS</b>	Defrost Run Hours	xxxxxx.x	hrs		HR_DFRST
<b>FULL LOAD HOURS</b>	Unit Full Load Run Hours	xxxxxx.x	hrs		HR_FLOAD
<b>FREE COOL HOURS</b>	Free Cooling Run Hours	xxxxxx.x	hrs		HR_FREEC
<b>HEAT 1 RUN HOURS</b>	Heat Stage 1 Run Hours	xxxxxx.x	hrs		HR_HTR_1
<b>HEAT 2 RUN HOURS</b>	Heat Stage 2 Run Hours	xxxxxx.x	hrs		HR_HTR_2
<b>IDF RUN HOURS</b>	Indoor Fan Run Hours	xxxxxx.x	hrs		HR_IDF
<b>LLSV RUN HOURS</b>	LiquidLineValv Run Hours	xxxxxx.x	hrs		HR_LLSV
<b>MAX IDF RUN HOURS</b>	Max Fan Speed Run Hours	xxxxxx.x	hrs		HR_MAXF
<b>MECH COOL HOURS</b>	MechanicalCool Run Hours	xxxxxx.x	hrs		HR_MECHC
<b>MECH HEAT HOURS</b>	MechanicalHeat Run Hours	xxxxxx.x	hrs		HR_MECHT
<b>ODF ON HOURS</b>	ODF Run Hours	xxxxxx.x	hrs		HR_ODF
<b>ODF RELAY HOURS</b>	ODF Relay Run Hours	xxxxxx.x	hrs		HR_OFR
<b>PE1 RELAY HOURS</b>	Power Exhaust1 Run Hours	xxxxxx.x	hrs		HR_PE_1
<b>PE2 RELAY HOURS</b>	Power Exhaust2 Run Hours	xxxxxx.x	hrs		HR_PE_2
<b>RVS_A RUN HOURS</b>	ReverseSolValv Run Hours	xxxxxx.x	hrs		HR_RVS_A
<b>TEST MODE HOURS</b>	Service Test Run Hours	xxxxxx.x	hrs		HR_STEST
<b>VENT IDF HOURS</b>	Vent IDF Run Hours	xxxxxx.x	hrs		HR_VENTF
<b>START COUNT DATA MENU</b>	Start Counts menu				
<b>2POS/ERV STARTS</b>	2Position/ERV Starts	xxxxxx			ST_ERV2P
<b>COMP A1 STARTS</b>	Compressor A1 Starts	xxxxxx			ST_A1
<b>CMP ALD STARTS</b>	CMP A1 Loader Starts	xxxxxx			ST_ALDR
<b>ALM RELAY STARTS</b>	Alarm Relay Starts	xxxxxx			ST_ALM
<b>ALM RESET COUNTS</b>	Alarm Reset Counts	xxxxxx			ST_ALRST
<b>CCH RELAY STARTS</b>	CCH1 Relay Starts	xxxxxx			ST_CCHR1
<b>DAMPER STARTS</b>	Economizer Damper Starts	xxxxxx			ST_DAMP
<b>DEFROST STARTS</b>	Defrost Mode Starts	xxxxxx			ST_DFRST
<b>FULL LOAD STARTS</b>	Unit Full Load Starts	xxxxxx			ST_FLOAD
<b>FREE COOL STARTS</b>	Free Cooling Starts	xxxxxx			ST_FREEC
<b>HEAT 1 STARTS</b>	Heat Stage 1 Starts	xxxxxx			ST_HTR_1
<b>HEAT 2 STARTS</b>	Heat Stage 2 Starts	xxxxxx			ST_HTR_2
<b>IDF STARTS</b>	Indoor Fan Starts	xxxxxx			ST_IDF
<b>LLSV STARTS</b>	Liquid Line Valve Starts	xxxxxx			ST_LLSV
<b>MAX IDF SPD START</b>	Max IDF Speed Starts	xxxxxx			ST_MAXF
<b>MECH COOL START</b>	Mechanical Cool Starts	xxxxxx			ST_MECHC
<b>MECH HEAT START</b>	Mechanical Heat Starts	xxxxxx			ST_MECHT
<b>ODF ON STARTS</b>	ODF Starts Count	xxxxxx			ST_ODF
<b>ODF RELAY STARTS</b>	ODF Relay Starts	xxxxxx			ST_OFR
<b>PE1 RELAY STARTS</b>	Power Exhaust 1 Starts	xxxxxx			ST_PE_1
<b>PE2 RELAY STARTS</b>	Power Exhaust 2 Starts	xxxxxx			ST_PE_2
<b>POR COUNT</b>	Power Cycle Counts	xxxxxx			ST_POR
<b>RVS_A STARTS</b>	ReverseSolValv Starts	xxxxxx			ST_RVS_A
<b>TEST MODE STARTS</b>	Service Test Starts	xxxxxx			ST_STEST
<b>VENT FAN STARTS</b>	Ventilation Fan Starts	xxxxxx			ST_VENTF
<b>RESET COUNTS MENU</b>	Reset Counts menu				
<b>2POS/ERV RESETS</b>	2Position/ERV ResetCount	xxxxxx			RS_ERV2P
<b>COMP A1 RESET QTY</b>	Comp A1 Resets Count	xxxxxx			RS_A1
<b>CMP ALD RESET QTY</b>	A1 Loader Resets Count	xxxxxx			RS_ALDR
<b>ALM RLY RESET QTY</b>	Alarm Relay Resets Count	xxxxxx			RS_ALM
<b>ALM RESET RESETS</b>	Alarm Reset Resets Count	xxxxxx			RS_ALRST
<b>CCH RELAY RESETS</b>	CCH1 Relay Resets Count	xxxxxx			RS_CCHR1
<b>DAMPER RESET QTY</b>	Econ Damper Resets Count	xxxxxx			RS_DAMP

**APPENDIX A — SYSTEMVU CONTROLLER DISPLAYS**

**SERVICE MAIN MENU LAYOUT (CONT)**

DISPLAY TEXT	EXPANDED DISPLAY TEXT	VALUES	UNITS	WRITE STATUS	POINT
<b>RESET COUNTS MENU (cont)</b>	Reset Counts menu				
<b>DEFROST RESET QTY</b>	Defrost Reset Count	xxxxxx			RS_DFRST
<b>FULL LOAD RESETS</b>	Full Load Resets Count	xxxxxx			RS_FLOAD
<b>FREE COOL RESETS</b>	Free Cooling Reset Count	xxxxxx			RS_FREEC
<b>HEAT 1 RESET QTY</b>	Heat Stage 1 Reset Count	xxxxxx			RS_HTR_1
<b>HEAT 2 RESET QTY</b>	Heat Stage 2 Reset Count	xxxxxx			RS_HTR_2
<b>IDF RESET QTY</b>	Indoor Fan Reset Count	xxxxxx			RS_IDF
<b>LLSV RESET QTY</b>	LiquidLineValv Reset Cnt	xxxxxx			RS_LLSV
<b>MAX IDF RESET QTY</b>	Max IDF Spd Resets Count	xxxxxx			RS_MAXF
<b>MECH.CL RESET QTY</b>	Mech Cool Reset Count	xxxxxx			RS_MECHC
<b>MECH.HT RESET QTY</b>	Mech Heat Reset Count	xxxxxx			RS_MECHT
<b>ODF ON RESET QTY</b>	ODF Resets Count	xxxxxx			RS_ODF
<b>ODF RELAY RESETS</b>	ODF Relay Resets Counts	xxxxxx			RS_OFR
<b>PE1 RESET QTY</b>	P.Exhaust 1 Resets Count	xxxxxx			RS_PE_1
<b>PE2 RESET QTY</b>	P.Exhaust 2 Resets Count	xxxxxx			RS_PE_2
<b>POR RESET QTY</b>	Power Cycle Resets Count	xxxxxx			RS_POR
<b>RVS_A RESET QTY</b>	RevSolValv Reset Count	xxxxxx			RS_RVS_A
<b>TEST MODE RESETS</b>	Service Test Reset Count	xxxxxx			RS_STEST
<b>VENT IDF RESETS</b>	Vent IDF Resets Count	xxxxxx			RS_VENTF
<b>POWER RESET HISTORY</b>	Power On Reset History Menu				
<b>POWRES00</b>	Power Reset Event 00	mm/dd/yy, hh:mm:ss			POWRES00
<b>POWRES01</b>	Power Reset Event 01	mm/dd/yy, hh:mm:ss			POWRES01
<b>POWRES02</b>	Power Reset Event 02	mm/dd/yy, hh:mm:ss			POWRES02
<b>POWRES03</b>	Power Reset Event 03	mm/dd/yy, hh:mm:ss			POWRES03
<b>POWRES04</b>	Power Reset Event 04	mm/dd/yy, hh:mm:ss			POWRES04
<b>POWRES05</b>	Power Reset Event 05	mm/dd/yy, hh:mm:ss			POWRES05
<b>POWRES06</b>	Power Reset Event 06	mm/dd/yy, hh:mm:ss			POWRES06
<b>POWRES07</b>	Power Reset Event 07	mm/dd/yy, hh:mm:ss			POWRES07
<b>POWRES08</b>	Power Reset Event 08	mm/dd/yy, hh:mm:ss			POWRES08
<b>POWRES09</b>	Power Reset Event 09	mm/dd/yy, hh:mm:ss			POWRES09
<b>ALARM RESET HISTORY</b>	Alarm Reset History Menu				
<b>ALMRES00</b>	Alarm Reset Event 00	mm/dd/yy, hh:mm:ss			ALMRES00
<b>ALMRES01</b>	Alarm Reset Event 01	mm/dd/yy, hh:mm:ss			ALMRES01
<b>ALMRES02</b>	Alarm Reset Event 02	mm/dd/yy, hh:mm:ss			ALMRES02
<b>ALMRES03</b>	Alarm Reset Event 03	mm/dd/yy, hh:mm:ss			ALMRES03
<b>ALMRES04</b>	Alarm Reset Event 04	mm/dd/yy, hh:mm:ss			ALMRES04
<b>ALMRES05</b>	Alarm Reset Event 05	mm/dd/yy, hh:mm:ss			ALMRES05
<b>ALMRES06</b>	Alarm Reset Event 06	mm/dd/yy, hh:mm:ss			ALMRES06
<b>ALMRES07</b>	Alarm Reset Event 07	mm/dd/yy, hh:mm:ss			ALMRES07
<b>ALMRES08</b>	Alarm Reset Event 08	mm/dd/yy, hh:mm:ss			ALMRES08
<b>ALMRES09</b>	Alarm Reset Event 09	mm/dd/yy, hh:mm:ss			ALMRES09
<b>ALMRES10</b>	Alarm Reset Event 10	mm/dd/yy, hh:mm:ss			ALMRES10
<b>ALMRES11</b>	Alarm Reset Event 11	mm/dd/yy, hh:mm:ss			ALMRES11
<b>ALMRES12</b>	Alarm Reset Event 12	mm/dd/yy, hh:mm:ss			ALMRES12
<b>ALMRES13</b>	Alarm Reset Event 13	mm/dd/yy, hh:mm:ss			ALMRES13
<b>ALMRES14</b>	Alarm Reset Event 14	mm/dd/yy, hh:mm:ss			ALMRES14
<b>ALMRES15</b>	Alarm Reset Event 15	mm/dd/yy, hh:mm:ss			ALMRES15
<b>ALMRES16</b>	Alarm Reset Event 16	mm/dd/yy, hh:mm:ss			ALMRES16
<b>ALMRES17</b>	Alarm Reset Event 17	mm/dd/yy, hh:mm:ss			ALMRES17
<b>ALMRES18</b>	Alarm Reset Event 18	mm/dd/yy, hh:mm:ss			ALMRES18
<b>ALMRES19</b>	Alarm Reset Event 19	mm/dd/yy, hh:mm:ss			ALMRES19
<b>HARDWARE</b>	Hardware Information Menu				
<b>HARDWARE INPUTS</b>	Hardware inputs menu				
<b>OAT SENSOR VALUE</b>	Outdoor Air Temp Sensor	xxx.x	°F		OAT_LOC
<b>RAT SENSOR VALUE</b>	Return Air Temp Sensor	xxx.x	°F		RAT_LOC
<b>SPT SENSOR VALUE</b>	Space Temperature Sensor	xxx.x	°F		SPT_LOC
<b>SPTO SENSOR VALUE</b>	Local Space Temp Offset	xxxx	ΔF		SPTO_LOC
<b>SPRH SENSOR VALUE</b>	SPRH Sensor Value	0 to 100	%		SPRH_LOC
<b>OARH SENSOR VALUE</b>	OARH Sensor Value	0 to 100	%		OARH_LOC
<b>RARH SENSOR VALUE</b>	RARH Sensor Value	0 to 100	%		RARH_LOC

## APPENDIX A — SYSTEMVU CONTROLLER DISPLAYS

### SERVICE MAIN MENU LAYOUT (CONT)

DISPLAY TEXT	EXPANDED DISPLAY TEXT	VALUES	UNITS	WRITE STATUS	POINT
<b>HARDWARE (cont)</b>	Hardware Information Menu				
<b>IAQ SENSOR VALUE</b>	IAQ Sensor value	xxxx	PPM		IAQ_LOC
<b>OAQ SENSOR VALUE</b>	OAQ Sensor Value	xxxx	PPM		OAQ_LOC
<b>OACFM SENSOR VALUE</b>	OACFM Sensor value	xxx.x	CFM		OACFM_LOC
<b>ASSIGNED INPUTS/OUTPUTS</b>	Assigned Input/Output Channels				
<b>AI06 FUNCTION</b>	Assigned AI06 Function	0=None, 1=IAQ, 2=OARH, 3=RARH, 4=OAQ, 5=SPRH, 6=OACFM			MBBAI06F
<b>AI07 FUNCTION</b>	Assigned AI07 Function				MBBAI07F
<b>AI08 FUNCTION</b>	Assigned AI08 Function				MBBAI08F
<b>DI02 FUNCTION</b>	Assigned DI02 Function	0=None, 1=COFS, 2=REMOCC, 3=REMOFF, 4=FILTER, 5=ENTHALPY, 6=GEN STAT, 7=HUMSTAT, 8=IAQOVRD, 9=SMK EVAC, 10=SMK PRESS, 11=SMK PURGE, 12=FIREDOWN, 13=FANSTATUS, 14=PHASEMON			MBBDI02F
<b>DI03 FUNCTION</b>	Assigned DI03 Function	See DI02 FUNCTION			MBBDI03F
<b>MBB Y3 FUNCTION</b>	Assigned MBB Y3 Function				MBBDI09F
<b>DI12 FUNCTION</b>	Assigned DI12 Function	See DI02 FUNCTION			MBBDI12F
<b>DI13 FUNCTION</b>	Assigned DI13 Function	See DI02 FUNCTION			MBBDI13F
<b>DI14 FUNCTION</b>	Assigned DI14 Function	See DI02 FUNCTION			MBBDI14F
<b>RELAY 06 FUNCTION</b>	Assigned Rly 06 Function	0=None, 1=ALM Relay, 2=PE1 ,3=PE2			MBBRY06F
<b>RELAY 11 FUNCTION</b>	Assigned Rly 11 Function				MBBRY11F
<b>MBB PART #</b>	MBB Part Number	CEPL131117-xx-R			BD_CEPL
<b>MBB PP #</b>	MBB Program Part Number	CEPP130644-xx-xx-xx-R			BD_CEPP
<b>MBB SERIAL #</b>	Base Board serial number	xxxxMxxxxx			BD_SER
<b>CALIBRATION</b>	Calibration Menu				
<b>OAT TRIM OFFSET</b>	OAT Sensor Trim Offset	-10 to 10	°F	Configurable	OAT_TRIM
<b>RAT TRIM OFFSET</b>	RAT Sensor Trim Offset	-30 to 30	°F	Configurable	RAT_TRIM
<b>FST TRIM OFFSET</b>	FST Sensor Trim Offset	-10 to 10	°F	Configurable	FST_TRIM
<b>SPT TRIM OFFSET</b>	SPT Sensor Trim Offset	-30 to 30	°F	Configurable	SPT_TRIM
<b>SLIDER SEN. TRIM</b>	SPTO Sensor Offset Trim	-1 to 1	°F	Configurable	SPTOTRIM
<b>SPRH TRIM OFFSET</b>	SPRH Sensor Trim Offset	-15 to 15	%	Configurable	SPRHTRIM
<b>IAQ TRIM OFFSET</b>	IAQ sensor trim offset	-200 to 200	PPM	Configurable	IAQ_TRIM
<b>OAQ TRIM OFFSET</b>	OAQ Sensor Trim Offset	-200 to 200	PPM	Configurable	OAQ_TRIM
<b>OARH TRIM OFFSET</b>	OARH Sensor Trim Offset	-15 to 15	%	Configurable	OARHTRIM
<b>RARH TRIM OFFSET</b>	RARH Sensor Trim Offset	-15 to 15	%	Configurable	RARHTRIM
<b>CIR.A SSP TRIM</b>	Cir.A SSP Sensor Trim	-50 to 50	PSI	Configurable	SSPATRIM
<b>CIR.A SDP TRIM</b>	Cir.A SDP Sensor Trim	-50 to 50	PSI	Configurable	SDPATRIM
<b>ECO FEEDBACK TRIM</b>	Econ Fdback Trim Offset	-15 to 15	%	Configurable	EC1DTRIM
<b>OACFM TRIM OFFSET</b>	OACFM sensor trim offset	-200 to 200	CFM	Configurable	OACFMTRIM
<b>ECON DAMPER CAL.</b>	Econ Damper Calibration				
<b>DMPR LO CAL ERROR</b>	Damper Low Calib. Error	xx	%		ECOMINCA
<b>DMPR HI CAL ERROR</b>	Damper High Calib. Error	xx	%		ECOMAXCA
<b>COMMISSION REPORTS</b>	Commission Report Menu				

## APPENDIX A — SYSTEMVU CONTROLLER DISPLAYS

### SERVICE MAIN MENU LAYOUT (CONT)

DISPLAY TEXT	EXPANDED DISPLAY TEXT	VALUES	UNITS	WRITE STATUS	POINT
<b>SYSTEM STARTUP CHECKLIST</b>	SYSTEM STARTUP CHECKLIST MENU				
<b>QUICK SET CHKLIST</b>	QUICK SETUP CHECKLIST	0=Undone, 1=Perform, 2=Done		Configurable	CHK_QUIK
<b>NETWORK CHKLIST</b>	NETWORK SETUP CHECKLIST	0=Undone, 1=Perform, 2=Done		Configurable	CHK_NET
<b>SYSTEM AUTOTEST</b>	Checklist Auto Test	0=Undone, 1=Perform, 2=Done		Configurable	CHK_ATST
<b>ADVANCED SERVICE</b>	Advanced Service Restricted Access Menu				
<b>RESTORE DEFAULTS?</b>	KEEPCONFIG SCREEN POP-UP	Yes/No		Command	RESFDFLT
<b>EDIT MODEL NUMBER</b>	Edit Equipment Model Number				
<b>EDIT SER NUMBER</b>	Edit Equip Ser Num Menu				
<b>CLEAR COMPONENT DATA</b>	RESET COMPONENT DATA MENU				
<b>2POS/ERV DATA</b>	Reset 2Position/ERV Data	Yes/No		Command	CR_ERV2P
<b>COMP A1 DATA</b>	Reset Compressor A1 Data	Yes/No		Command	CR_A1
<b>ALARM RELAY DATA</b>	Reset Alarm Relay Data	Yes/No		Command	CR_ALM
<b>ALARM RESET DATA</b>	Reset Alarm Resets Data	Yes/No		Command	CR_ALRST
<b>CCH RELAY DATA</b>	Reset CCH1 Relay Data	Yes/No		Command	CR_CCHR1
<b>ECON DAMPER DATA</b>	Reset Econ Damper Data	Yes/No		Command	CR_DAMP
<b>DEFROST DATA</b>	Reset Defrost run Data	Yes/No		Command	CR_DFRST
<b>FULL LOAD DATA</b>	Reset Full Load Data	Yes/No		Command	CR_FLOAD
<b>FREE COOL DATA</b>	Reset Free Cooling Data	Yes/No		Command	CR_FREEC
<b>HEAT 1 DATA</b>	Reset Heat Stage 1 Data	Yes/No		Command	CR_HTR_1
<b>HEAT 2 DATA</b>	Reset Heat Stage 2 Data	Yes/No		Command	CR_HTR_2
<b>IDF RUN DATA</b>	Reset Indoor Fan Data	Yes/No		Command	CR_IDF
<b>LLSV DATA</b>	Reset LLSV run Data	Yes/No		Command	CR_LLSV
<b>MECH COOL DATA</b>	Reset Mech Cool run Data	Yes/No		Command	CR_MECHC
<b>MECH HEAT DATA</b>	Reset MECHT run Data	Yes/No		Command	CR_MECHT
<b>ODF ON DATA</b>	Reset ODF Run Data	Yes/No		Command	CR_ODF
<b>ODF RELAY DATA</b>	Reset ODF Speed Relay	Yes/No		Command	CR_OFR
<b>IDF MAX SPD DATA</b>	Reset Max Fan Speed Data	Yes/No		Command	CR_MAXF
<b>PE1 RELAY DATA</b>	Reset Pwr Exhaust 1 Data	Yes/No		Command	CR_PE_1
<b>PE2 RELAY DATA</b>	Reset Pwr Exhaust 2 Data	Yes/No		Command	CR_PE_2
<b>POWER RESET DATA</b>	Reset Power Resets Data	Yes/No		Command	CR_POR
<b>RVS_A DATA</b>	Reset RVS_A run Data	Yes/No		Command	CR_RVS_A
<b>TEST MODE DATA</b>	Reset Service Test Data	Yes/No		Command	CR_STEST
<b>VENT IDF DATA</b>	Reset Vent IDF Data	Yes/No		Command	CR_VENTF
<b>RESTRICTED ACCESS</b>	Restricted Access Only				
<b>IDF CURVE LO PWM</b>	IDF Curve Low End PWM	0 to 100	%	Configurable	IFMLOPWM
<b>IDF CURVE HI PWM</b>	IDF Curve High End PWM	0 to 100	%	Configurable	IFMHIPWM
<b>MIN SPEED TIME</b>	IDF Start Speed Time	xxx	sec	Configurable	IDFSSTIM
<b>MIN START SPEED</b>	IDF Min Start RPM	xxxx	RPM	Configurable	IDFSTSPD

## APPENDIX A — SYSTEMVU CONTROLLER DISPLAYS

### INPUTS MAIN MENU LAYOUT

DISPLAY TEXT	EXPANDED DISPLAY TEXT	VALUES	UNITS	WRITE STATUS	POINT
<b>INPUTS</b>	Inputs Menu				
<b>TEMPERATURES</b>	Temperatures Menu				
<b>SUPPLY AIR TEMP</b>	Supply Air Temperature	xxx..x	°F		SAT
<b>OUTDOOR AIR TEMP</b>	Outdoor Air Temperature	xxx.x	°F	Forcible	OAT
<b>RETURN AIR TEMP</b>	Return Air Temperature	xxx.x	°F	Forcible	RAT
<b>SPACE TEMPERATURE</b>	Space Temperature	xxx.x	°F	Forcible	SPACE_T
<b>SLIDER OFFSET VAL</b>	Space Temperature Offset	xx.x	ΔF	Forcible	SPTO
<b>CIR.A SUC TEMP</b>	Cir.A Sat.Suction Temp	xxx.x	°F		SST_A
<b>CIR.A DIS. TEMP</b>	Cir.A Sat.Discharge Temp	xxx.x	°F		SDT_A
<b>FAN SUPPLY TEMP</b>	Fan Supply Air Temp	xxx.x	°F		FST
<b>PRESSURES</b>	Pressures Menu				
<b>CIR.A SUC. PRESS</b>	Cir.A Suction Pressure	xxx.x	PSI		SSP_A
<b>CIR.A DIS. PRESS</b>	Cir.A Discharge Pressure	xxx.x	PSI		SDP_A
<b>CIR.A PRESS RATIO</b>	Circuit A Pressure Ratio	xx.xx			CIRA_PR
<b>BAROMETRIC PRESS</b>	Barometric Pressure	xx.xx	Hg	Forcible	BARP
<b>THERMOSTAT</b>	Thermostat Inputs menu				
<b>TSTAT G INPUT</b>	Thermostat G Input	On/Off		Forcible	G
<b>TSTAT Y1 INPUT</b>	Thermostat Y1 Input	On/Off		Forcible	Y1
<b>TSTAT Y2 INPUT</b>	Thermostat Y2 Input	On/Off		Forcible	Y2
<b>TSTAT W1 INPUT</b>	Thermostat W1 Input	On/Off		Forcible	W1
<b>TSTAT W2 INPUT</b>	Thermostat W2 Input	On/Off		Forcible	W2
<b>SWITCH INPUTS</b>	Switch Inputs Menu				
<b>DEFROST SWITCH</b>	Defrost Switch	Open/Close			DFRST_SW
<b>CIR.A HPS</b>	Cir.A High Pressure Sw	Open/Close			CIRA_HPS
<b>IDF LIMIT SWITCH</b>	IDF Manual Limit Switch	Open/Close			IDF_LSM
<b>HUMIDISTAT</b>	Humidistat Input	On/Off		Forcible	HUMDSTAT
<b>FIRE SHUTDOWN</b>	Fire Shutdown Switch	Alarm/Normal		Forcible	FIREDOWN
<b>COFS</b>	COFS Switch State	High/Low		Forcible	COFS
<b>PHASE MONITOR SW</b>	Phase Monitor Switch	Alarm/Normal		Forcible	PMR_STAT
<b>FILTER STATUS SW</b>	Filter Status Switch	Dirty/Clean		Forcible	FILTSTAT
<b>REMOTE OCC SWITCH</b>	Remote Occupancy Switch	On/Off		Forcible	REMOCC
<b>REMOTE SHUTDOWN</b>	Remote Shutdown Switch	On/Off		Forcible	REMSHUT
<b>FAN STATUS SWITCH</b>	Fan Status Switch	On/Off		Forcible	FAN_STAT
<b>GENERAL STATUS SW</b>	General Status Switch	Alarm/Normal		Forcible	GENSTAT
<b>IAQ OVRRD SWITCH</b>	IAQ Override Switch	On/Off		Forcible	IAQ_OVRS
<b>ENTHALPY SWITCH</b>	Enthalpy Switch	High/Low		Forcible	ENTH_SW
<b>SMOKE PURGE INPUT</b>	Smoke Purge Switch	On/Off		Forcible	PURGE
<b>SMOKE PRESSURE</b>	Smoke Pressure Switch	On/Off		Forcible	PRESSURE
<b>SMOKE EVAC INPUT</b>	Smoke Evacuation Switch	On/Off		Forcible	EVAC
<b>ANALOG INPUTS</b>	ANALOG Inputs Menu				
<b>ECON ACT POSITION</b>	Damper Actual Position	0 to 100	%		DAMPPOS
<b>SPRH LEVEL</b>	Space Relative Humidity	0 to 100	%	Forcible	SPRH
<b>OARH LEVEL</b>	OA Relative Humidity	0 to 100	%	Forcible	OARH
<b>RARH LEVEL</b>	RA Relative Humidity	0 to 100	%	Forcible	RARH
<b>IAQ LEVEL</b>	Indoor Air Quality Level	xxxx	PPM	Forcible	IAQ
<b>OAQ LEVEL</b>	OA Quality Level	xxxx	PPM	Forcible	OAQ
<b>OUTDOOR AIR CFM</b>	Outdoor Air in CFM	0 to 8000	CFM	Forcible	OACFM
<b>GENERAL INPUTS</b>	General Inputs Menu				
<b>FILTER TIME LEFT</b>	Filter hour remaining	xxxx	hrs		FILTLEFT
<b>RESET FILTER TIME</b>	Reset Filter Timer	Yes/No		Command	RESETFLT
<b>OUTDOOR ENTHALPY</b>	Outdoor Air Enthalpy	-9.6 to 334.2	BTU/LB	Forcible	OA_ENTH
<b>RETURN ENTHALPY</b>	Return Air Enthalpy	-9.6 to 334.2	BTU/LB	Forcible	RA_ENTH
<b>DIFF AIR QUALITY</b>	Differential Air Quality	-5000 to 5000	PPM		AQ_DIFF
<b>NETWORK</b>	Network Menu				
<b>BMS OCC REQUEST</b>	BMS Occupancy Request	0=UNOCC, 1=OCCUPIED, 2=DISABLED		Forcible	BMS_OCC
<b>LINKAGE OCC REQ</b>	Linkage Occupied Request	0=Unocc, 1=Occupied, 2=Disabled		Forcible	LNK_OCC
<b>OAT NETWORK VALUE</b>	Network OAT Value	xxx.x	°F	Forcible	OAT_NET

## APPENDIX A — SYSTEMVU CONTROLLER DISPLAYS

### INPUTS MAIN MENU LAYOUT (CONT)

DISPLAY TEXT	EXPANDED DISPLAY TEXT	VALUES	UNITS	WRITE STATUS	POINT
<b>NETWORK (cont)</b>	Network Menu				
<b>RAT NETWORK VALUE</b>	Network Return Air Temp	xxx.x	°F	Forcible	RAT_NET
<b>SPT NETWORK VAL.</b>	Network Space Temp Value	xxx.x	°F	Forcible	SPT_NET
<b>SPRH NETWORK VAL</b>	Network SPRH Value	0 to 100	%	Forcible	SPRH_NET
<b>OARH NETWORK VAL.</b>	Network OARH Value	0 to 100	%	Forcible	OARH_NET
<b>RARH NETWORK VAL.</b>	Network RARH Value	0 to 100	%	Forcible	RARH_NET
<b>IAQ NETWORK VALUE</b>	Network IAQ Value	xxxx	PPM	Forcible	IAQ_NET
<b>OAQ NETWORK VALUE</b>	Network OAQ Value	xxxx	PPM	Forcible	OAQ_NET
<b>OACFM NETWORK VAL</b>	Network OACFM Value	xxx.x	CFM	Forcible	OACFM_NET
<b>ZS SENSOR INFO</b>	ZS Sensor Information				
<b>ZS SPACE TEMP</b>	Zone Sensor Temp Out	0	°F		ZSZT
<b>ZS SPACE RH</b>	Zone Sensor Humidity Out	0	%		ZSSPRH
<b>ZS SPOFFSET</b>	ZS Setpoint OffsetOutput	0	ΔF		ZSSPTO
<b>ZS OVR TIME LEFT</b>	ZS Override time remain	0	min		ZSOTR
<b>ZS TEMPERATURE</b>	ZS Space Temperature				
<b>ZS1 TEMPERATURE</b>	Zone Sensor 1 Temp	0	°F		ZS1ZT
<b>ZS2 TEMPERATURE</b>	ZS2 Temperature	0	°F		ZS2ZT
<b>ZS3 TEMPERATURE</b>	ZS3 Temperature	0	°F		ZS3ZT
<b>ZS4 TEMPERATURE</b>	ZS4 Temperature	0	°F		ZS4ZT
<b>ZS5 TEMPERATURE</b>	ZS5 Temperature	0	°F		ZS5ZT
<b>ZS HUMIDITY</b>	ZS Space Humidity				
<b>ZS1 HUMIDITY</b>	ZS1 Humidity	0	%		ZS1ZHUM
<b>ZS2 HUMIDITY</b>	ZS2 Humidity	0	%		ZS2ZHUM
<b>ZS3 HUMIDITY</b>	ZS3 Humidity	0	%		ZS3ZHUM
<b>ZS4 HUMIDITY</b>	ZS4 Humidity	0	%		ZS4ZHUM
<b>ZS5 HUMIDITY</b>	ZS5 Humidity	0	%		ZS5ZHUM
<b>ZS CSP OFFSET</b>	ZS Cool Set Point Offset				
<b>ZS1 CSP OFFSET</b>	ZS1 cool setpoint offset	0	ΔF		ZS1CSOFF
<b>ZS2 CSP OFFSET</b>	ZS2 cool setpoint offset	0	ΔF		ZS2CSOFF
<b>ZS3 CSP OFFSET</b>	ZS3 cool setpoint offset	0	ΔF		ZS3CSOFF
<b>ZS4 CSP OFFSET</b>	ZS4 cool setpoint offset	0	ΔF		ZS4CSOFF
<b>ZS5 CSP OFFSET</b>	ZS5 cool setpoint offset	0	ΔF		ZS5CSOFF
<b>ZS HSP OFFSET</b>	ZS Heat Set Point Offset				
<b>ZS1 HSP OFFSET</b>	ZS1 Heat Setpoint Offset	0	ΔF		ZS1HSOFF
<b>ZS2 HSP OFFSET</b>	ZS2 Heat Setpoint Offset	0	ΔF		ZS2HSOFF
<b>ZS3 HSP OFFSET</b>	ZS3 Heat Setpoint Offset	0	ΔF		ZS3HSOFF
<b>ZS4 HSP OFFSET</b>	ZS4 Heat Setpoint Offset	0	ΔF		ZS4HSOFF
<b>ZS5 HSP OFFSET</b>	ZS5 Heat Setpoint Offset	0	ΔF		ZS5HSOFF
<b>ZS OCC TIME OVER</b>	ZS Occ Timed Override				
<b>ZS1 OCC TIME OVER</b>	ZS1 Override time remain	0	min		ZS1OTR
<b>ZS2 OCC TIME OVER</b>	ZS2 Override time remain	0	min		ZS2OTR
<b>ZS3 OCC TIME OVER</b>	ZS3 Override time remain	0	min		ZS3OTR
<b>ZS4 OCC TIME OVER</b>	ZS4 Override time remain	0	min		ZS4OTR
<b>ZS5 OCC TIME OVER</b>	ZS5 Override time remain	0	min		ZS5OTR

## APPENDIX A — SYSTEMVU CONTROLLER DISPLAYS

### OUTPUTS MAIN MENU LAYOUT

DISPLAY TEXT	EXPANDED DISPLAY TEXT	VALUES	UNITS	WRITE STATUS	POINT
<b>OUTPUTS</b>	Outputs Menu				
<b>GENERAL OUTPUTS</b>	General Outputs Menu				
<b>COMMANDED IDF RPM</b>	IDF Commanded RPM	xxxx	RPM		FSPD_RPM
<b>ECON CMD POSITION</b>	Econo Commanded Position	0 to 100	%	Forcible	DAMPCMD
<b>CCH RELAY</b>	CCH Relay 1 State	On/Off			CCHR1
<b>PE1 RELAY</b>	Power Exhaust 1 Relay	On/Off		Forcible	PE1
<b>PE2 RELAY</b>	Power Exhaust 2 Relay	On/Off		Forcible	PE2
<b>ALARM RELAY</b>	Alarm Output Relay State	On/Off		Forcible	ALMOUT
<b>2POS/ERV RELAY</b>	2-Pos Damper/ERV relay	On/Off		Forcible	ERV_2POS
<b>COOLING OUTPUTS</b>	Cooling Outputs Menu				
<b>COMPRESSOR A1</b>	Circuit A Compressor 1	On/Off			COMP_A1
<b>COMP A LOADER</b>	Circuit A CMP A1 Loader	On/Off			COMP_ALD
<b>ODF SPEED RELAY</b>	Outdoor Fan Speed Relay	On/Off			OFR
<b>ODF ON/OFF RELAY</b>	ODF On/Off Relay	On/Off			ODF_ON
<b>REVERSING VALVE</b>	Rev.Valve Solenoid Cir.A	On/Off			RVS_A
<b>HEATING OUTPUTS</b>	Heating Outputs Menu				
<b>COMPRESSOR A1</b>	Circuit A Compressor 1	On/Off			COMP_A1
<b>COMP A LOADER</b>	Circuit A CMP A1 Loader	On/Off			COMP_ALD
<b>ODF SPEED RELAY</b>	Outdoor Fan Speed Relay	On/Off			OFR
<b>ODF ON/OFF RELAY</b>	ODF On/Off Relay	On/Off			ODF_ON
<b>REVERSING VALVE</b>	Rev.Valve Solenoid Cir.A	On/Off			RVS_A
<b>LIQUID LINE VALVE</b>	Liquid Solenoid Valve	On/Off			LLSV
<b>HEAT 1 RELAY</b>	Heat Stage 1 Relay	On/Off			HEAT_1
<b>HEAT 2 RELAY</b>	Heat Stage 2 Relay	On/Off			HEAT_2

## APPENDIX A — SYSTEMVU CONTROLLER DISPLAYS

### USB MAIN MENU LAYOUT (CONT)

DISPLAY TEXT	EXPANDED DISPLAY TEXT	VALUES	UNITS	WRITE STATUS	POINT
<b>USB</b>	USB Menu				
<b>DATA ACQUISITION</b>	Data Acquisition Menu				
<b>TREND STATUS</b>	USB TREND STATUS	0=IDLE, 1=TRENDING, 2=NO POINTS, 3=USB FULL			TRNDSTAT
<b>TREND DURATION</b>	USB TREND DURATION	0=1 MINUTE, 1=5 MINUTES, 2=15 MINUTES, 3=30 MINUTES, 4=1 HOUR, 5=3 HOURS, 6=8 HOURS, 7=12 HOURS, 8=1 DAYS, 9=1.5 DAYS, 10=2 DAYS, 11=3 DAYS, 12=5 DAYS, 13=1 WEEK, 14=2 WEEK, 15=4 WEEK, 16=USB FULL		Command	TRND DUR
<b>TREND RATE</b>	USB TREND RATE	1 to 300		Command	TRNDRATE
<b>TREND POINTS FROM</b>	USB TREND POINTS FROM	0=FILE, 1=LIST		Command	TRNDPNTS
<b>TREND FROM USB FILE?</b>	TREND FROM USB FILE MENU				
<b>TREND FROM PRELIST?</b>	TREND FROM PRELIST MENU				
<b>EQUIP PERFORMANCE</b>	TREND EQUIP PERFORMANCE	On/Off		Command	TRNDEQPR
<b>GEN. INPUT/OUTPUT</b>	TREND GEN INPUTS/OUTPUTS	On/Off		Command	TRNDIO
<b>COOL PERFORMANCE</b>	TREND COOL PERFORMANCE	On/Off		Command	TRNDCLPR
<b>HEAT PERFORMANCE</b>	TREND HEAT PERFORMANCE	On/Off		Command	TRNDHTPR
<b>COOL DIAGNOSTIC</b>	TREND COOLING DIAGNOSTIC	On/Off		Command	TRNDCLDG
<b>IDF DIAGNOSTIC</b>	TREND IDF DIAGNOSTIC	On/Off		Command	TRNDIDF
<b>VENT DIAGNOSTIC</b>	TREND VENTILATION	On/Off		Command	TRNDVENT
<b>TREND GO?</b>	Start USB Trending	Yes/No		Command	TREND_EN
<b>SAVE CONFIGS TO FILE</b>	Save Configuration to file				
<b>SAVE CONFIGS</b>	Make Config Backup File	Start/Stop		Command	DDBCKUP
<b>SAVE CONFIG STATUS</b>	Backup File is ready	0=IDLE, 1=SUCCESS, 2=FAILURE			BACKUP_R
<b>SAVE CONFIGS FROM FILE</b>	Save Configuration from file				
<b>FIND CONFIG FILE</b>	USB Find Restore File	Yes/No		Command	BACKFILE
<b>FILE TRANSFER</b>	File Transfer Menu				
<b>BACKUP SERVICE FILES</b>	BACKUP SERVICE FILES				
<b>UPGRADE SOFTWARE</b>	Upgrade Software Menu				
<b>FIND APPLICATION FILE</b>	USB search for app file	Yes/No		Command	APPFILE



## APPENDIX B — SYSTEMVU CONTROLLER TEXT POINT REFERENCE

SystemVu Display Name = MODE

SystemVu Text point = MODETEXT

SystemVu Numeric point = SYSMODE

MODETEXT	SYS_MODE
OFF	1
COOL	2
HEAT	3
VENT	4
TEST	5

SystemVu Display Name = SUB-MODE

SystemVu Text point = SUBTEXT

SystemVu Numeric point = SUB\_MODE

SUBTEXT	SUB_MODE
ECON FREE COOLING	3
UNOCC. FREE COOL	4
MECH. COOLNG	5
ECON/MECH COOLING	6
DEHUM/MECH COOLING	7
DEHUMIDIFYING	8
DEHUM PREVENTED	9
COOLING PREVENTED	10
SHUTTING COOL OFF	11
HEATING	13
HEATING PREVENTED	14
SHUTTING HEAT OFF	15
SA TEMPERING	16
DEFROST	17
MODE TIMEGUARD	19, 26
SUPPLY FAN ON	20
MANUAL TEST	23
AUTO TEST	24
SHUTTING TEST OFF	25
IDLE - NO DEMAND	27
UNIT DISABLED	28
URGENT SHUTDOWN	29
SAFETY CONTROL	30
STARTING UP	31
PURGING SMOKE	32
PRESSURIZING	33
EVACUATING SMOKE	34

SystemVu Display Name = VENT MODE

SystemVu Text point = VENTTEXT

SystemVu Numeric point = VENTSTAT

VENTTEXT	VENTSTAT
SUPPLY FAN OFF	0
CIRCULATION	1
PRE-OCC PURGE	2
IAQ OVERRIDE	3
MINIMUM POSITION	4
UNDER VENTILATION	5
OVER VENTILATION	6
DCV POSITION	7
FREECOOL POSITION	8
TESTING	9

SystemVu Display Name = DEMAND

SystemVu Text point = SYSDDMDT

SystemVu Numeric point = SYS\_DMD

SYSDDMDT	SYS_DMD
NO DEMAND	0
DEHUM	4, 12
FAN ONLY	8
LOW COOL	17, 25
MED COOL	18, 26
HIGH COOL	19, 27
LOW COOL DEHUM	21, 29
MED COOL DEHUM	22, 30
HIGH COOL DEHUM	23, 31
LOW HEAT	33, 37, 41, 45
HIGH HEAT	35, 39, 43, 47
SERVICE TEST	49
SHUTDOWN	65
SAFETY FAULT	66
EMERGENCY	67
UFC LOW COOL	81
UFC MED COOL	82
UFC HIGH COOL	83
LOW UFC DEHUM	85
MED UFC DEHUM	86
HIGH UFC DEHUM	87
SMOKE PURGE	97
SMOKE PRESSURE	98
SMOKE EVAC	99
SATEMPERING	129, 137

## APPENDIX C — NAVIGATOR™ DISPLAY

### MODE – RUN STATUS

DISPLAY TEXT	EXPANDED DISPLAY TEXT	VALUES	UNITS	WRITE STATUS	POINT
<b>RUN STATUS</b>	Run Status Menu				
<b>VIEW</b>	View Menu				
<b>MODE</b>	Operating Mode	see Appendix B			MODETEXT
<b>SUBM</b>	Operating Sub-Mode	see Appendix B			SUBMTEXT
<b>S.DMD</b>	System Demand	see Appendix B			SYS_DMDT
<b>LINK</b>	Linkage Active	Yes/No		Forcible	LNK_ACT
<b>OCC</b>	Currently Occupied	Yes/No		Forcible	OCCUPIED
<b>SAT</b>	Supply Air Temperature	xxx..x	°F		SAT
<b>COOL</b>	Cooling Status Menu				
<b>MC.ON</b>	Mechanical Cool active?	Yes/No			MECHCOOL
<b>MAX.C</b>	Max Allowed Cool Stages	0 to 3		Forcible	MAXCSTGS
<b>REQ.C</b>	Requested Cooling Stages	0 to 3			REQCSTGS
<b>ACT.C</b>	Actual Cool Stage Active	x			ACTCSTGS
<b>TG.A1</b>	Compressor A1 Timeguard	xxx	sec		TIMGD_A1
<b>TG.AL</b>	Comp A1 Loader Timeguard	xxx	sec		TIMG_ALD
<b>FC.ON</b>	Free Cooling active	Yes/No			FREECOOL
<b>REQ.D</b>	Requested Damper Pos	0 to 100	%		REQDAMP
<b>HEAT</b>	Heating Status Menu				
<b>C.SPD</b>	IDF Commanded RPM	xxxx	RPM		FSPD_RPM
<b>HS.TY</b>	Active Type of Heat	0=NONE, 1=MECH ONLY, 2=MECH+1EH, 3=MECH+2EH, 4=ELCTHT1, 5=EH1+EH2, 6=DEFROST			HTSRCTYP
<b>EC.CP</b>	Econo Commanded Position	xxx	%	Forcible	DAMPCMD
<b>H.LOC</b>	All Heat Stages Lockout	Yes/No			ALLHTLOC
<b>DF.A</b>	Defrost Mode Active	Yes/No			DFRSTACT
<b>OK.HT</b>	OK to Run Hea	Yes/No			OKTOHEAT
<b>REQ.H</b>	Requested Heating Stages	x			REQHSTGS
<b>ACT.H</b>	Actual Heat Stage Active	x			ACTHSTGS
<b>MAX.H</b>	Max Allowed Heat Stages	0 to 2		Forcible	MAXHSTGS
<b>TG.H1</b>	Heat Stage 1 Timeguard	xxx	sec		TIMGD_H1
<b>TG.H2</b>	Heat Stage 2 Timeguard	xxx	sec		TIMGD_H2
<b>DF.TR</b>	Defrost Mode Timer	xxxx	sec		DF_TIMER
<b>DF.IR</b>	Defrost Interval Timer	xxxx	sec		DFINT_T
<b>H2.DT</b>	Heat2 delay timer	xxx	sec		H2DLTMR
<b>H1.AV</b>	Heat Stage 1 Available	Yes/No			HT1_AVAL
<b>H2.AV</b>	Heat Stage 2 Available	Yes/No			HT2_AVAL
<b>OK.ST</b>	OK to SupplyAirTempering	Yes/No			OKTOTEMP
<b>ME.H</b>	Mechanical Heating Menu				
<b>MH.ON</b>	Mechanical Heating	Yes/No			MECHT_EN
<b>OD.ST</b>	ODF State	0=OFF, 1=ON, 2=LOW, 3=HIGH			ODFSTATE
<b>TG.A1</b>	Compressor A1 Timeguard	xxx	sec		TIMGD_A1
<b>TG.AL</b>	Comp A1 Loader Timeguard	xxx	sec		TIMG_ALD
<b>SA.TR</b>	Supply Air Temp Trend	xxx.x			SATTREND
<b>ST.A1</b>	Compressor A1 strikes	x			A1STRIKE
<b>C.LO</b>	Circuit A Locked Out	Yes/No			CIRALOCK
<b>A1.AV</b>	Compressor A1 Available	Yes/No			CA1_AVAL
<b>A1.LO</b>	Compressor A1 Locked Out	Yes/No			CA1_LOCK
<b>VENT</b>	Ventilation Status Menu				
<b>VENT</b>	Ventilation Status	see Appendix B			VENTTEXT
<b>EC.MP</b>	Min Position in Effect	0 to 100	%	Forcible	MIN_POS
<b>OCC</b>	Currently Occupied	Yes/No		Forcible	OCCUPIED

## APPENDIX C — NAVIGATOR™ DISPLAY

### MODE – RUN STATUS (CONT)

DISPLAY TEXT	EXPANDED DISPLAY TEXT	VALUES	UNITS	WRITE STATUS	POINT
<b>A.IO</b>	ASSIGNED INPUTS/OUPUTS				
<b>AI06</b>	Assigned AI06 Function	0=None, 1=IAQ, 2=OARH, 3=RARH, 4=OAQ, 5=SPRH, 6=OACFM			MBBAI06F
<b>AI07</b>	Assigned AI07 Function	0=None, 1=IAQ, 2=OARH, 3=RARH, 4=OAQ, 5=SPRH, 6=OACFM			MBBAI07F
<b>AI08</b>	Assigned AI08 Function	0=None, 1=IAQ, 2=OARH, 3=RARH, 4=OAQ, 5=SPRH, 6=OACFM			MBBAI08F
<b>DI02</b>	Assigned DI02 Function	0=None, 1=COFS, 2=REMOCC, 3=REMOFF, 4=FILTER, 5=ENTHALPY, 6=GEN STAT, 7=HUMSTAT, 8=IAQOVRD, 9=SMK EVAC, 10=SMK PRESS, 11=SMK PURGE, 12=FIREDOWN, 13=FANSTATUS, 14=PHASEMON			MBBDI02F
<b>DI03</b>	Assigned DI03 Function	0=None, 1=COFS, 2=REMOCC, 3=REMOFF, 4=FILTER, 5=ENTHALPY, 6=GEN STAT, 7=HUMSTAT, 8=IAQOVRD, 9=SMK EVAC, 10=SMK PRESS, 11=SMK PURGE, 12=FIREDOWN, 13=FANSTATUS, 14=PHASEMON			MBBDI03F
<b>DI.Y3</b>	Assigned MBB Y3 Function	0=None, 1=COFS, 2=REMOCC, 3=REMOFF, 4=FILTER, 5=ENTHALPY, 6=GEN STAT, 7=HUMSTAT, 8=IAQOVRD, 9=SMK EVAC, 10=SMK PRESS, 11=SMK PURGE, 12=FIREDOWN, 13=FANSTATUS, 14=PHASEMON			MBBDI09F

## APPENDIX C — NAVIGATOR™ DISPLAY

### MODE – RUN STATUS (CONT)

DISPLAY TEXT	EXPANDED DISPLAY TEXT	VALUES	UNITS	WRITE STATUS	POINT
<b>A.IO (cont)</b>	ASSIGNED INPUTS/OUPUTS				
<b>DI12</b>	Assigned DI12 Function	0=None, 1=COFS, 2=REMOCC, 3=REMOFF, 4=FILTER, 5=ENTHALPY, 6=GEN STAT, 7=HUMSTAT, 8=IAQOVRD, 9=SMK EVAC, 10=SMK PRESS, 11=SMK PURGE, 12=FIREDOWN, 13=FANSTATUS, 14=PHASEMON			MBBDI12F
<b>DI13</b>	Assigned DI13 Function	0=None, 1=COFS, 2=REMOCC, 3=REMOFF, 4=FILTER, 5=ENTHALPY, 6=GEN STAT, 7=HUMSTAT, 8=IAQOVRD, 9=SMK EVAC, 10=SMK PRESS, 11=SMK PURGE, 12=FIREDOWN, 13=FANSTATUS, 14=PHASEMON			MBBDI13F
<b>DI14</b>	Assigned DI14 Function	0=None, 1=COFS, 2=REMOCC, 3=REMOFF, 4=FILTER, 5=ENTHALPY, 6=GEN STAT, 7=HUMSTAT, 8=IAQOVRD, 9=SMK EVAC, 10=SMK PRESS, 11=SMK PURGE, 12=FIREDOWN, 13=FANSTATUS, 14=PHASEMON			MBBDI14F
<b>RY06</b>	Assigned Rly 06 Function	0=None, 1=ALM Relay, 2=PE1, 3=PE2			MBBRY06F
<b>RY11</b>	Assigned Rly 11 Function	0=None, 1=ALM Relay, 2=PE1, 3=PE2			MBBRY11F
<b>VERS</b>	Versions Menu				
<b>MODL</b>	Equipment Model number	xxxxxxxxxxxxxxxxxxx			EQ_MOD
<b>SERL</b>	Equipment Serial number	xxxxxxxxxx			EQ_SER
<b>SW</b>	Application SW Version	text			FW_CESR
<b>BOOT</b>	Bootloader SW Version	text			BL_CESR

## APPENDIX C — NAVIGATOR™ DISPLAY

### MODE – SERVICE TEST

DISPLAY TEXT	EXPANDED DISPLAY TEXT	VALUES	UNITS	WRITE STATUS	POINT
<b>SERVICE TEST</b>	Service Test Menu				
<b>TEST</b>	Service Test Mode Enable	On/Off			
<b>INDP</b>	INDEPENDENT TEST MENU				
<b>DAMP</b>	Economizer Position Test	0 to 100	%		S_DAMPER
<b>BMP1</b>	Compressor Bump A1 Test	On/Off			S_BMPA1
<b>S.RV</b>	Rev.Val. Sole. Cir.A Tst	On/Off			S_RVS_A
<b>S.LL</b>	LiqLine Solenoid Test	On/Off			S_LLSV
<b>CCH1</b>	Crankcase Heater 1 test	On/Off			S_CCHR1
<b>ALRM</b>	Alarm Output Relay Test	On/Off			S_ALARM
<b>PE1</b>	Power Exhaust 1 Test	On/Off			S_PE_1
<b>PE2</b>	Power Exhaust 2 Test	On/Off			S_PE_2
<b>2P.EV</b>	2Position/ERV Relay Test	On/Off			S_ERV2P
<b>E.CAL</b>	Econ Damper Calibration	On/Off			S_ECOCAL
<b>FAN</b>	FAN TESTS				
<b>IDFS</b>	Indoor Fan Speed Test	0 to 100	%		S_IDFSPD
<b>IF.SP</b>	Converted IDF Speed	0 to 5000	RPM		IFRPMTST
<b>IF.TR</b>	IDF Manual Transition	Yes/No			S_IDFTRN
<b>T.ODF</b>	ODF On/Off Relay Test	On/Off			S_ODFON
<b>T.OFR</b>	ODF Speed Relay Test	On/Off			S_OFRSPD
<b>COOL</b>	Cooling Test Menu				
<b>CL.A1</b>	Cooling W/Comp.A1 Test	On/Off			S_COOLA1
<b>CL.AL</b>	Cooling W/Comp.ALD Test	On/Off			S_COLALD
<b>IDFS</b>	Indoor Fan Speed Test	0 to 100	%		S_IDFSPD
<b>T.ODF</b>	ODF On/Off Relay Test	On/Off			S_ODFON
<b>OFR</b>	ODF Speed Relay Test	On/Off			S_OFRSPD
<b>HEAT</b>	Heating Test Menu				
<b>HT.1</b>	Heating Stage 1 Test	On/Off			S_HEAT1
<b>HT.2</b>	Heating Stage 2 Test	On/Off			S_HEAT2
<b>T.MHT</b>	Mechanical Heating Test	On/Off			S_MECHT
<b>T.DFR</b>	Defrost Test	On/Off			S_DFRST
<b>IDFS</b>	Indoor Fan Speed Test	0 to 100	%		S_IDFSPD

## APPENDIX C — NAVIGATOR™ DISPLAY

### MODE – TEMPERATURES

ITEM	EXPANSION	VALUES	UNITS	WRITE STATUS	POINT
<b>TEMPERATURES</b>	Temperature Menu				
<b>SAT</b>	Supply Air Temperature	xxx..x	°F		SAT
<b>OAT</b>	Outdoor Air Temperature	xxx.x	°F	Forcible	OAT
<b>RAT</b>	Return Air Temperature	xxx.x	°F	Forcible	RAT
<b>SPT</b>	Space Temperature	xxx.x	°F	Forcible	SPACE_T
<b>SPTO</b>	Space Temperature Offset	xx.x	ΔF	Forcible	SPTO
<b>SST.A</b>	Cir.A Sat.Suction Temp	xxx.x	°F		SST_A
<b>SDT.A</b>	Cir.A Sat.Discharge Temp	xxx.x	°F		SDT_A
<b>FST</b>	Fan Supply Air Temp	xxx.x	°F		FST

### MODE – PRESSURES

ITEM	EXPANSION	VALUES	UNITS	WRITE STATUS	POINT
<b>PRESSURES</b>	Pressures Menu				
<b>SSP.A</b>	Cir. A Suction Pressure	xxx.x	PSI		SSP_A
<b>SDP.A</b>	Cir. A Discharge Pressure	xxx.x	PSI		SDP_A
<b>PR.A</b>	Circuit A Pressure Ratio	xx.xx			CIRA_PR
<b>BARP</b>	Barometric Pressure	xx.xx		Forcible	BARP

### MODE – SETPOINTS

ITEM	EXPANSION	VALUES	UNITS	DEFAULT	POINT
<b>SETPOINTS</b>	Setpoint Menu				
<b>OCSP</b>	Occupied Cool Setpoint	55 to 80	°F	78	OCSP
<b>OHSP</b>	Occupied Heat Setpoint	55 to 80	°F	68	OHSP
<b>UCSP</b>	Unoccupied Cool Setpoint	65 to 95	°F	85	UCSP
<b>UHSP</b>	Unoccupied Heat Setpoint	40 to 80	°F	60	UHSP
<b>GAP</b>	Heat-Cool Setpoint Gap	2 to 10	°F	5	HCSP_GAP
<b>STO.R</b>	SPT Offset Range (+/-)	0 to 5	°F	5	SPTO_RNG
<b>RH.OS</b>	Occupied SPRH Setpoint	0 to 100	%	50	SPRH_OSP
<b>RH.US</b>	Unoccupied SPRH Setpoint	0 to 100	%	80	SPRH_USP
<b>RH.DB</b>	Space RH Deadband	2 to 20	%	8	SPRH_DB

## APPENDIX C — NAVIGATOR™ DISPLAY

### MODE – INPUTS

ITEM	EXPANSION	VALUES	UNITS	WRITE STATUS	POINT
<b>INPUTS</b>	Inputs Menu				
<b>STAT</b>	Thermostat Inputs menu				
<b>G</b>	Thermostat G Input	On/Off		Forcible	G
<b>Y1</b>	Thermostat Y1 Input	On/Off		Forcible	Y1
<b>Y2</b>	Thermostat Y2 Input	On/Off		Forcible	Y2
<b>W1</b>	Thermostat W1 Input	On/Off		Forcible	W1
<b>W2</b>	Thermostat W2 Input	On/Off		Forcible	W2
<b>SW</b>	Switch Inputs Menu				
<b>DF.SW</b>	Defrost Switch	Open/Close			DFRST_SW
<b>HPS.A</b>	Cir.A High Pressure Sw	Open/Close			CIRA_HPS
<b>F.LSM</b>	IDF Manual Limit Switch	Open/Close			IDF_LSM
<b>HUMD</b>	Humidistat Input	On/Off		Forcible	HUMDSTAT
<b>FDWN</b>	Fire Shutdown Switch	Alarm/Normal		Forcible	FIREDOWN
<b>COFS</b>	COFS Switch State	High/Low		Forcible	COFS
<b>PMR</b>	Phase Monitor Switch	Alarm/Normal			PMR_STAT
<b>FIL.S</b>	Filter Status Switch	Dirty/Clean		Forcible	FILTSTAT
<b>RM.OC</b>	Remote Occupancy Switch	On/Off		Forcible	REMOCC
<b>R.OFF</b>	Remote Shutdown Switch	On/Off		Forcible	REMSHUT
<b>FAN.S</b>	Fan Status Switch	On/Off			FAN_STAT
<b>GEN.S</b>	General Status Switch	Alarm/Normal		Forcible	GENSTAT
<b>IAQ.O</b>	IAQ Override Switch	On/Off		Forcible	IAQ_OVRS
<b>ENTH</b>	Enthalpy Switch	High/Low		Forcible	ENTH_SW
<b>PURG</b>	Smoke Purge Switch	On/Off		Forcible	PURGE
<b>PRES</b>	Smoke Pressure Switch	On/Off		Forcible	PRESSURE
<b>EVAC</b>	Smoke Evacuation Switch	On/Off		Forcible	EVAC
<b>AIS</b>	ANALOG Inputs Menu				
<b>EC.AP</b>	Damper Actual Position	0 to 100	%		DAMPPOS
<b>SPRH</b>	Space Relative Humidity	0 to 100	%	Forcible	SPRH
<b>OARH</b>	OA Relative Humidity	0 to 100	%	Forcible	OARH
<b>RARH</b>	RA Relative Humidity	0 to 100	%	Forcible	RARH
<b>IAQ</b>	Indoor Air Quality Level	xxxx	PPM	Forcible	IAQ
<b>OAQ</b>	OA Quality Level	xxxx	PPM	Forcible	OAQ
<b>OCFM</b>	Outdoor Air in CFM	0 to 8000	CFM	Forcible	OACFM
<b>GEN</b>	General Inputs Menu				
<b>FT.RM</b>	Filter hour remaining	xxxx	hrs		FILTLEFT
<b>R.FLT</b>	Reset Filter Timer	Yes/No			RESETFLT
<b>OAE</b>	Outdoor Air Enthalpy	-9.6 to 334.2		Forcible	OA_ENTH
<b>RAE</b>	Return Air Enthalpy	-9.6 to 334.2		Forcible	RA_ENTH
<b>DF.AQ</b>	Differential Air Quality	-5000 to 5000	PPM		AQ_DIFF

## APPENDIX C — NAVIGATOR™ DISPLAY

### MODE – OUTPUTS

ITEM	EXPANSION	VALUES	UNITS	WRITE STATUS	POINT
<b>OUTPUTS</b>	Outputs Menu				
<b>GEN</b>	General Outputs Menu				
<b>C.SPD</b>	IDF Commanded RPM	0 to 3000	RPM		FSPD_RPM
<b>EC.CP</b>	Econo Commanded Position	0 to 100	%	Forcible	DAMPCMD
<b>CCH</b>	CCH Relay 1 State	On/Off			CCHR1
<b>PE.1</b>	Power Exhaust 1 Relay	On/Off		Forcible	PE1
<b>PE.2</b>	Power Exhaust 2 Relay	On/Off		Forcible	PE2
<b>ALRM</b>	Alarm Output Relay State	On/Off		Forcible	ALMOUT
<b>EV2P</b>	2-Pos Damper/ERV relay	On/Off			ERV_2POS
<b>COOL</b>	Cooling Outputs Menu				
<b>C.A1</b>	Circuit A Compressor 1	On/Off			COMP_A1
<b>C.AL</b>	Circuit A CMP A1 Loader	On/Off			COMP_ALD
<b>OFR</b>	Outdoor Fan Speed Relay	On/Off			OFR
<b>OF.R2</b>	ODF On/Off Relay	On/Off			ODF_ON
<b>RVS.A</b>	Rev.Valve Solenoid Cir.A	On/Off			RVS_A
<b>HEAT</b>	Heating Outputs Menu				
<b>C.A1</b>	Circuit A Compressor 1	On/Off			COMP_A1
<b>C.AL</b>	Circuit A CMP A1 Loader	On/Off			COMP_ALD
<b>OF.R</b>	Outdoor Fan Speed Relay	On/Off			OFR
<b>OF.R2</b>	ODF On/Off Relay	On/Off			ODF_ON
<b>LL.SV</b>	Liquid Solenoid Valve	On/Off			LLSV
<b>RVS.A</b>	Rev.Valve Solenoid Cir.A	On/Off			RVS_A
<b>HT.1</b>	Heat Stage 1 Relay	On/Off			HEAT_1
<b>HT.2</b>	Heat Stage 2 Relay	On/Off			HEAT_2



## APPENDIX C — NAVIGATOR™ DISPLAY

### MODE – CONFIGURATIONS

ITEM	EXPANSION	VALUES	UNITS	DEFAULTS	POINT
<b>CONFIGURATION</b>	Configuration				
<b>GEN</b>	GENERAL				
<b>S.DLY</b>	Unit Startup Delay	10 to 600	sec	30	STARTDLY
<b>U.CTL</b>	Unit Control Type	0=TSTAT, 1=SPACE SEN, 2=RAT SEN		0 = TSTAT	CTRLTYPE
<b>T.CTL</b>	Thermostat Hardware Type	0=CONV 2C2H, 1=DIGI 2C2H, 2=CONV 3C2H, 3=DIGI 3C2H		0 = CONV 2C2H	STATTYPE
<b>VNT.C</b>	Ventilation Method	0=NONE, 1=ECON, 2=2POS DMPR, 3=ERV, 4=ECON ERV		0: No FIOP 1: Economizer FIOP 2: Two Position Damper FIOP	VENTTYPE
<b>FT.TM</b>	Change Filter Timer	0 to 9999	hrs	0	FILT LIFE
<b>T.TO</b>	Test Inactivity Time Out	0=Disabled, 1=30 minutes, 2=1 hour, 3=2 hours, 4=4 hours, 5=8 hours, 6=12 hours		4	TEST_ITO
<b>CA.LO</b>	Circuit A Lockout Temp	-20 to 75	°F	40: no FIOP 0: Low Ambient FIOP	OATLCMPA
<b>D.INV</b>	Min Time BTWN Defrosts	30 to 120	min	60	MINDFINT
<b>N.HTR</b>	Number Of Heating Stages	0 to 2		1	NUMHSTGS
<b>HT.LO</b>	Heating Lockout Temp	40 to 125	°F	75	OATLHEAT
<b>MH.LO</b>	Mech Heat Lockout Temp	-30 to 40	°F	-8	OATLMECH
<b>I.FAN</b>	INDOOR FAN				
<b>S.MAX</b>	IDF Maximum Fan Speed	0 to 100	%	100	SPEEDMAX
<b>S.VNT</b>	IDF Vent Speed-RPM	0 to 3000	RPM	same as S.LCL	RPM_VENT
<b>S.HT</b>	IDF Heat Speed-RPM	0 to 3000	RPM	same as S.HCL	RPM_HEAT
<b>S.LCL</b>	IDF Low Cool Speed-RPM	0 to 3000	RPM	1106: Size 04 Standard Static Fan 1281: Size 04 Medium Static Fan 1457: Size 04 High Static Fan 1112: Size 05 Standard Static Fan 1269: Size 05 Medium Static Fan 1439: Size 05 High Static Fan 230v 1 ph 1556: Size 05 High Static Fan 230v 3ph, 460v, 575v 1258: Size 06 Standard Static Fan 1398: Size 06 Medium Static Fan 1556: Size 06 High Static Fan 230v 1 ph 1659: Size 06 High Static Fan 230v 3ph, 460v, 575v 1184: Size 07 Standard Static Fan 1302: Size 07 Medium Static Fan 1460: Size 07 High Static Fan	RPM_LCL
<b>S.HCL</b>	IDF High Cool Speed-RPM	0 to 3000	RPM	1474: Size 04 Standard Static Fan 1708: Size 04 Medium Static Fan 1942: Size 04 High Static Fan 1482: Size 05 Standard Static Fan 1693: Size 05 Medium Static Fan 1919: Size 05 High Static Fan 230v 1 ph 2075: Size 05 High Static Fan 230v 3ph, 460v, 575v 1677: Size 06 Standard Static Fan 1864: Size 06 Medium Static Fan 2075: Size 06 High Static Fan 230v 1 ph 2212: Size 06 High Static Fan 230v 3ph, 460v, 575v 1794: Size 07 Standard Static Fan 1973: Size 07 Medium Static Fan 2212: Size 07 High Static Fan	RPM_HCL
<b>S.FCL</b>	IDF Free Cool Speed-RPM	0 to 3000	RPM	same as S.LCL	RPM_FCL

## APPENDIX C — NAVIGATOR™ DISPLAY

### MODE – CONFIGURATIONS (CONT)

ITEM	EXPANSION	VALUES	UNITS	DEFAULTS	POINT
<b>ECON</b>	ECONOMIZER				
<b>VNT.C</b>	Ventilation Method	0=NONE, 1=ECON, 2=2POS DMPR, 3=ERV, 4=ECON ERV		0: No FIOP 1: Economizer FIOP 2: Two Position Damper FIOP	VENTTYPE
<b>FC.MX</b>	Free Cooling Max OAT	0 to 90	°F	65	MAXFREET
<b>EC.MX</b>	Econ Max Damper Position	0 to 100	%	100	DAMPMAX
<b>MIN.P</b>	MINIMUM POSITION CONFIGS				
<b>MP.MX</b>	Econ Min at Max Fanspeed	0 to 100	%	30	MINP_MAX
<b>MP.S1</b>	Min Pos - User Speed 1	0 to 100	%	0	MP_USPD1
<b>MP.D1</b>	Min Pos - User Pos 1	0 to 100	%	0	MP_UPOS1
<b>MP.S2</b>	Min Pos - User Speed 2	0 to 100	%	0	MP_USPD2
<b>MP.D2</b>	Min Pos - User Pos 2	0 to 100	%	0	MP_UPOS2
<b>MP.S3</b>	Min Pos - User Speed 3	0 to 100	%	0	MP_USPD3
<b>MP.D3</b>	Min Pos - User Pos 3	0 to 100	%	0	MP_UPOS3
<b>NET</b>	NETWORK SETTINGS				
<b>BAS</b>	BAS Protocol Select	0=NONE, 1=CCN, 2=BACNET		2 = BACNET	BMS_CFG
<b>NW.TO</b>	Network Input Timeout	0 to 600	min	30	NETINTO
<b>CCN</b>	CCN				
<b>CCN.B</b>	CCN Bus number	0 to 239		0	CCNBUS
<b>CCN.A</b>	CCN Element Number	1 to 239		1	CCNADD
<b>BAUD</b>	CCN Baud Rate	0=9600, 1=19200, 2=38400		2 = 38400	BAUDENUM
<b>BNET</b>	BACNET				
<b>MAC</b>	BACnet Device Macaddress	1 to 127		1	BAC_MAC
<b>BAUD</b>	BACnet BMS baud rate	0=9600, 1=19200, 2=38400, 3=57600, 4=76800, 5=115200		4 = 76800	BAC_BAUD
<b>AUID</b>	ALC Auto Id Scheme	Yes/No		Yes	AUID
<b>B.AID</b>	BACnet ID Auto ID	Yes/No		Yes	BAC_AUID
<b>ID</b>	BACnet ID Number	0 to 4194302		1610101	BAC_ID
<b>DISP</b>	DISPLAY SETTINGS				
<b>METR</b>	Metric Display	Yes/No		No	DISPUNIT
<b>LANG</b>	Display Language Select	0=English, 1=Spanish, 2=French, 3=Portuguese		0 = English	LANGUAGE
<b>PROT</b>	User Password Protection	Enable/Disable		Enable	PASS_EBL
<b>PSWD</b>	User Password	0 to 9999		1111	PASSWORD

## APPENDIX C — NAVIGATOR™ DISPLAY

### MODE – TIME CLOCK

ITEM	EXPANSION	RANGE	UNITS	DEFAULT	POINT
<b>TIME CLOCK</b>					
<b>TIME</b>	Clock Hour and Minute	xx:xx	hh.mm		
<b>MNTH</b>	Month of Year	1=JANUARY, 2=FEBRUARY, 3=MARCH, 4=APRIL, 5=MAY, 6=JUNE, 7=JULY, 8=AUGUST, 9=SEPTEMBER, 10=OCTOBER, 11=NOVEMBER, 12=DECEMBER			MOY
<b>DOM</b>	Day Of month	1 to 31			DOM
<b>YEAR</b>	Year	2000 to 9999			YOC_DISP
<b>DAY</b>	Day Of week	1=MONDAY, 2=TUESDAY, 3=WEDNESDAY, 4=THURSDAY, 5=FRIDAY, 6=SATURDAY, 7=SUNDAY			dow
<b>DST.A</b>	DST currently active	Yes/No			DST_ACTV
<b>DST</b>	Daylight Savings Config				
<b>DST</b>	DST allowed?	Enable/Disable		Enable	DST_CFG
<b>STR.M</b>	DST Start Month	1=JANUARY, 2=FEBRUARY, 3=MARCH, 4=APRIL, 5=MAY, 6=JUNE, 7=JULY, 8=AUGUST, 9=SEPTEMBER, 10=OCTOBER, 11=NOVEMBER, 12=DECEMBER		3	STARTM
<b>STR.W</b>	DST Start Week	1 to 5		2	STARTW
<b>STR.D</b>	DST Start Day	1=MONDAY, 2=TUESDAY, 3=WEDNESDAY, 4=THURSDAY, 5=FRIDAY, 6=SATURDAY, 7=SUNDAY		7	STARTD
<b>M.ADD</b>	DST Minutes to Add	0 to 90	min	60	MINADD
<b>STP.M</b>	DST Stop Month	1=JANUARY, 2=FEBRUARY, 3=MARCH, 4=APRIL, 5=MAY, 6=JUNE, 7=JULY, 8=AUGUST, 9=SEPTEMBER, 10=OCTOBER, 11=NOVEMBER, 12=DECEMBER		11	STOPM
<b>STP.W</b>	DST Stop Week	1 to 5		1	STOPW
<b>STP.D</b>	DST Stop Day	1=MONDAY, 2=TUESDAY, 3=WEDNESDAY, 4=THURSDAY, 5=FRIDAY, 6=SATURDAY, 7=SUNDAY		7	STOPD
<b>M.SUB</b>	DST Minutes to Subtract	0 to 90	min	60	MINSUB
<b>TOD</b>	Time in day to start DST	0 to 600	min	120	DST_TOD

**APPENDIX C — NAVIGATOR™ DISPLAY**

**MODE – TIME CLOCK (CONT)**

ITEM	EXPANSION	RANGE	UNITS	DEFAULT	POINT
<b>SCHD</b>	Schedules Adjust Menu				
<b>SCH.N</b>	CCN Schedule Number	0 = Always Occupied, 1-64 = Local Schedule, 65-99 = Global Schedule	n/a	0	SCHEDNUM
<b>OV.TL</b>	Timed Override Duration	0 to 4	hours	4	OTL_CFG
<b>MON</b>	Mon Schedule Adjust Menu				
<b>OC.x</b>	Monday Occupied x	00:00 to 24:00 or None	HH:MM	None	MO_OC1 - MO_OC8
<b>UOC.x</b>	Monday Unoccupied x	00:00 to 24:00 or None	HH:MM	None	MO_UNOC1 - MO_UNOC8
<b>TUE</b>	Tue Schedule Adjust Menu				
<b>OC.x</b>	Tuesday Occupied x	00:00 to 24:00 or None	HH:MM	None	TU_OC1 - TU_OC8
<b>UOC.x</b>	Tuesday Unoccupied x	00:00 to 24:00 or None	HH:MM	None	TU_UNOC1 - TU_UNOC8
<b>WED</b>	Wed Schedule Adjust Menu				
<b>OC.x</b>	Wednesday Occupied x	00:00 to 24:00 or None	HH:MM	None	WE_OC1 - WE_OC8
<b>UOC.x</b>	Wednesday Unoccupied x	00:00 to 24:00 or None	HH:MM	None	WE_UNOC1 - WE_UNOC8
<b>THU</b>	Thu Schedule Adjust Menu				
<b>OC.x</b>	Thursday Occupied x	00:00 to 24:00 or None	HH:MM	None	TH_OC1 - TH_OC8
<b>UOC.x</b>	Thursday Unoccupied x	00:00 to 24:00 or None	HH:MM	None	TH_UNOC1 - TH_UNOC8
<b>FRI</b>	Fri Schedule Adjust Menu				
<b>OC.x</b>	Friday Occupied x	00:00 to 24:00 or None	HH:MM	None	FR_OC1 - FR_OC8
<b>UOC.x</b>	Friday Unoccupied x	00:00 to 24:00 or None	HH:MM	None	FR_UNOC1 - FR_UNOC8
<b>SAT</b>	Sat Schedule Adjust Menu				
<b>OC.x</b>	Saturday Occupied x	00:00 to 24:00 or None	HH:MM	None	SA_OC1 - SA_OC8
<b>UOC.x</b>	Saturday Unoccupied x	00:00 to 24:00 or None	HH:MM	None	SA_UNOC1 - SA_UNOC8
<b>SUN</b>	Sun Schedule Adjust Menu				
<b>OC.x</b>	Sunday Occupied x	00:00 to 24:00 or None	HH:MM	None	SU_OC1 - SU_OC8
<b>UOC.x</b>	Sunday Unoccupied x	00:00 to 24:00 or None	HH:MM	None	SU_UNOC1 - SU_UNOC8
<b>HOL</b>	Hol Schedule Adjust Menu				
<b>OC.x</b>	Holiday Occupied x	00:00 to 24:00 or None	HH:MM	None	HD_OC1 - HD_OC8
<b>UOC.x</b>	Holiday Unoccupied x	00:00 to 24:00 or None	HH:MM	None	HD_UNOC1 - HD_UNOC8
<b>(repeat up to x=8 Periods)</b>					
<b>HLDY</b>	Holiday adjustment Menu				
<b>HOL.G</b>	Accept Global Holidays?	Yes/No		No	HOLIDAYT
<b>HL.TY</b>	Today Is A Holiday	Yes/No			HOLTODAY
<b>HL.TW</b>	Tomorrow Is A Holiday	Yes/No			HOL_TMRW
<b>HO.xx</b>	Holiday adjustment Menu				
<b>LEN</b>	Holiday Duration (days)	0 to 99		0	HD01LEN - HD30LEN
<b>DAY</b>	Holiday Start Day	0 to 31		0	HD01STDY - HD30STDY
<b>MON</b>	Holiday Start Month	0 to 12 = January to December		0	HD01STMN - HD30STMN
<b>(repeat up to xx=30 Holidays)</b>					

## APPENDIX C — NAVIGATOR™ DISPLAY

### MODE – OPERATING MODES

ITEM	EXPANSION	RANGE	UNITS	WRITE STATUS	POINT
<b>OPERATING MODES</b>	Operating Modes Menu				
<b>MODE</b>	Operating Mode	see Appendix B			MODETEXT
<b>SUBM</b>	Operating Sub-Mode	see Appendix B			SUBMTEXT
<b>S.DMD</b>	System Demand	see Appendix B			SYS_DMDT
<b>LINK</b>	Linkage Active	Yes/No		Forcible	LNK_ACT
<b>CLTG</b>	Cool Mode Select T.guard	xxx	sec		COOLMSTG
<b>HTTG</b>	Heat Mode Select T.guard	xxx	sec		HEATMSTG

### MODE – ALARMS

ITEM	EXPANSION	RANGE	DEFAULT	POINT
<b>ALARMS</b>				
<b>CURR</b>	Curr Active Alarm Menu			
<b>alarm#</b>	text string			ALARM01C - ALARM25C
<b>(repeat up to 25 times)</b>				
<b>HIST</b>	History Menu			
<b>alarm#</b>	alarm# - mm/dd/yy-hh.mm- text string			ALHIS001 - ALHIS050
<b>(repeat up to 50 times)</b>				
<b>R.CUR</b>	Reset All Current Alarms	Yes/No	Yes	ALRESET
<b>R.HIS</b>	Alarm Reset History Menu			
<b>ARxx</b>	mm/dd/yy, hh:mm:ss			ALMRES00 - ALMRES19
<b>(repeat up to 20 times)</b>				

**APPENDIX D — SYSTEMVU™ CONTROLLER CCN TABLES**

**STATUS DISPLAY TABLES**

TABLE	DISPLAY NAME	VALUES	UNITS	POINT NAME	WRITE STATUS	
UINPUT	Supply Air Temperature	xxx..x	°F	SAT		
	Outdoor Air Temperature	xxx.x	°F	OAT	Forcible	
	Return Air Temperature	xxx.x	°F	RAT	Forcible	
	Space Temperature	xxx.x	°F	SPACE_T	Forcible	
	Space Temperature Offset	xx.x	ΔF	SPTO	Forcible	
	Fan Supply Air Temp	xxx.x	°F	FST		
	Cir.A Sat.Suction Temp	xxx.x	°F	SST_A		
	Cir.A Sat.Discharge Temp	xxx.x	°F	SDT_A		
	Cir.A Suction Pressure	xxx.x	PSI	SSP_A		
	Cir.A Discharge Pressure	xxx.x	PSI	SDP_A		
	Thermostat G Input	On/Off		G	Forcible	
	Thermostat Y1 Input	On/Off		Y1	Forcible	
	Thermostat Y2 Input	On/Off		Y2	Forcible	
	Thermostat W1 Input	On/Off		W1	Forcible	
	Thermostat W2 Input	On/Off		W2	Forcible	
	Defrost Switch	Open/Close		DFRST_SW		
	Humidistat Input	On/Off		HUMDSTAT	Forcible	
	IDF Manual Limit Switch	Open/Close		IDF_LSM		
	Cir.A High Pressure Sw	Open/Close		CIRA_HPS		
	Fire Shutdown Switch	Alarm/Normal		FIREDOWN	Forcible	
	COFS Switch State	High/Low		COFS	Forcible	
	Filter Status Switch	Dirty/Clean		FILTSTAT	Forcible	
	Phase Monitor Switch	Alarm/Normal		PMR_STAT		
	Fan Status Switch	On/Off		FAN_STAT		
	Remote Occupancy Switch	On/Off		REMOCC	Forcible	
	Remote Shutdown Switch	On/Off		REMSHUT	Forcible	
	General Status Switch	Alarm/Normal		GENSTAT	Forcible	
	IAQ Override Switch	On/Off		IAQ_OVRS	Forcible	
	Enthalpy Switch	High/Low		ENTH_SW	Forcible	
	Smoke Purge Switch	On/Off		PURGE	Forcible	
	Smoke Pressure Switch	On/Off		PRESSURE	Forcible	
	Smoke Evacuation Switch	On/Off		EVAC	Forcible	
	Damper Actual Position	0 to 100	%	DAMPPOS		
	Space Relative Humidity	0 to 100	%	SPRH	Forcible	
	OA Relative Humidity	0 to 100	%	OARH	Forcible	
	RA Relative Humidity	0 to 100	%	RARH	Forcible	
	Indoor Air Quality Level	xxxx	PPM	IAQ	Forcible	
	OA Quality Level	xxxx	PPM	OAQ	Forcible	
	Outdoor Air in CFM	0 to 8000	CFM	OACFM	Forcible	
UOUTPUT	IDF Commanded RPM	0 to 3000	RPM	FSPD_RPM		
	Econo Commanded Position	0 to 100	%	DAMPCMD	Forcible	
	CCH Relay 1 State	On/Off		CCHR1		
	Power Exhaust 1 Relay	On/Off		PE1	Forcible	
	Power Exhaust 2 Relay	On/Off		PE2	Forcible	
	Alarm Output Relay State	On/Off		ALMOUT	Forcible	
	2-Pos Damper/ERV relay	On/Off		ERV_2POS		
	Circuit A Compressor 1	On/Off		COMP_A1		
	Circuit A CMP A1 Loader	On/Off		COMP_ALD		
	ODF On/Off Relay	On/Off		ODF_ON		
	Outdoor Fan Speed Relay	On/Off		OFR		
	Heat Stage 1 Relay	On/Off		HEAT_1		
	Heat Stage 2 Relay	On/Off		HEAT_2		
	Rev.Valve Solenoid Cir.A	On/Off		RVS_A		
	Liquid Solenoid Valve	On/Off		LLSV		

**APPENDIX D — SYSTEMVU™ CONTROLLER CCN TABLES**

**STATUS DISPLAY TABLES (CONT)**

TABLE	DISPLAY NAME	VALUES	UNITS	POINT NAME	WRITE STATUS
<b>GENDISP</b>	Circuit A Pressure Ratio	xx.xx		CIRA_PR	
	Barometric Pressure	xx.xx	"Hg	BARP	Forcible
	Filter hour remaining	xxxx	hrs	FILTLEFT	
	Reset Filter Timer	Yes/No		RESETFLT	Writable
	Outdoor Air Enthalpy	-9.6 to 334.2	BTU_LB	OA_ENTH	Forcible
	Return Air Enthalpy	-9.6 to 334.2	BTU_LB	RA_ENTH	Forcible
	Differential Air Quality	-5000 to 5000	PPM	AQ_DIFF	
	DST currently active	Yes/No		DST_ACTV	
	Network OAT Value	xxx.x	°F	OAT_NET	Forcible
	Network Return Air Temp	xxx.x	°F	RAT_NET	Forcible
	Network Space Temp Value	xxx.x	°F	SPT_NET	Forcible
	Network SPRH Value	0 to 100	%	SPRH_NET	Forcible
	Network OARH Value	0 to 100	%	OARH_NET	Forcible
	Network RARH Value	0 to 100	%	RARH_NET	Forcible
	Network IAQ Value	xxxx	PPM	IAQ_NET	Forcible
	Network OAQ Value	xxxx	PPM	OAQ_NET	Forcible
Network OACFM Value	xxx.x	CFM	OCFM_NET	Forcible	
<b>MODEDISP</b>					
	System Mode	see Appendix B		SYSMODE	
	Running Mode Operation	see Appendix B		SUB_MODE	
	Ventilation Status	see Appendix B		VENTSTAT	
	System Demand	0 to 99		SYS_DMD	
	Currently Occupied	Yes/No		OCCUPIED	Forcible
	Linkage Active	Yes/No		LNK_ACT	
	Unocc Free Cool Active	Yes/No		UFC_ACT	
	Temp Compensate Start On	Yes/No		TCS_ACT	
	Cool Setpoint in Effect	xx.x	°F	CSP_EFF	
	Heat Setpoint in Effect	xx.x	°F	HSP_EFF	
	Effective Demand Temp	xxx.x	°F	TEMP_EFF	
	Cool Demand Limiting	Yes/No		CDMLMOFF	
	Cool Demand limit offset	0	°F	COOLDLMO	
	Heat Demand Limiting	0		HDMLMOFF	
	Heat Demand Limit offset	0	°F	HEATDLMO	
Cool demand Limit Level	0 to 3		CDMDLLEV		
Heat demand Limit Level	0 to 3		HDMDLLEV		
<b>COOLDISP</b>					
	OK to Use Free Cooling?	Yes/No		OKFREECL	
	Free Cooling active	Yes/No		FREECOOL	
	Free Cooling SAT Setpnt	xx.x	°F	FC_SATSP	
	Econo Commanded Position	0 to 100	%	DAMPCMD	Forcible
	IDF Commanded RPM	0 to 3000	RPM	FSPD_RPM	
	Ok to use compressors?	Yes/No		OKMECHCL	
	Mechanical Cool active?	Yes/No		MECHCOOL	
	Max Allowed Cool Stages	0 to 3		MAXCSTGS	Forcible
	Requested Cooling Stages	0 to 3		REQCSTGS	
	Actual Cool Stage Active	x		ACTCSTGS	
	Circuit A Compressor 1	On/Off		COMP_A1	
	Circuit A CMP A1 Loader	On/Off		COMP_ALD	
	Rev.Valve Solenoid Cir.A	On/Off		RVS_A	
	Compressor A1 Timeguard	xxx	sec	TIMGD_A1	
	Comp A1 Loader Timeguard	xxx	sec	TIMG_ALD	
	Ok to use Fan Dehum	Yes/No		OKTOFBD	
	Cir.A Sat.Discharge Temp	xxx.x	°F	SDT_A	
	Cir.A Sat.Suction Temp	xxx.x	°F	SST_A	
Cir.A Discharge Pressure	xxx.x	PSI	SDP_A		
Cir.A Suction Pressure	xxx.x	PSI	SSP_A		

**APPENDIX D — SYSTEMVU™ CONTROLLER CCN TABLES**

**STATUS DISPLAY TABLES (CONT)**

TABLE	DISPLAY NAME	VALUES	UNITS	POINT NAME	WRITE STATUS
<b>COOLDISP (cont)</b>	Circuit A Pressure Ratio	xx.xx		CIRA_PR	
	Cir.A High Pressure Sw	Open/Close		CIRA_HPS	
	Supply Air Temperature	xxx..x	°F	SAT	
	Outdoor Air Temperature	xxx.x	°F	OAT	Forcible
	ODF State	0=OFF, 1=ON, 2=LOW, 3=HIGH		ODFSTATE	
	Outdoor Fan Speed Relay	On/Off		OFR	
	ODF On/Off Relay	On/Off		ODF_ON	
	<b>HEATDISP</b>	OK to Run Heat	Yes/No		OKTOHEAT
OK to SupplyAirTempering		Yes/No		OKTOTEMP	
IDF Commanded RPM		0 to 3000	RPM	FSPD_RPM	
Max Allowed Heat Stages		0 to 2		MAXHSTGS	Forcible
Requested Heating Stages		0 to 2		REQHSTGS	
Actual Heat Stage Active		x		ACTHSTGS	
Heat Stage 1 Relay		On/Off		HEAT_1	
Heat Stage 2 Relay		On/Off		HEAT_2	
Heat Stage 1 Timeguard		xxx	sec	TIMGD_H1	
Heat Stage 2 Timeguard		xxx	sec	TIMGD_H2	
Defrost Mode Active		Yes/No		DFRSTACT	
Defrost Switch		Open/Close		DFRST_SW	
Mechanical Heating		Yes/No		MECHT_EN	
Defrost Mode Active		Yes/No		DFRSTACT	
Defrost Mode Timer		xxxx	sec	DF_TIMER	
Defrost Interval Timer		xxxx	sec	DFINT_T	
Heat2 delay timer		xxx	sec	H2DLTMR	
Circuit A Compressor 1		On/Off		COMP_A1	
Circuit A CMP A1 Loader		On/Off		COMP_ALD	
Rev.Valve Solenoid Cir.A		On/Off		RVS_A	
Compressor A1 Timeguard		xxx	sec	TIMGD_A1	
Comp A1 Loader Timeguard		xxx	sec	TIMG_ALD	
ODF State		0=OFF, 1=ON, 2=LOW, 3=HIGH		ODFSTATE	
Outdoor Fan Speed Relay		On/Off		OFR	
ODF On/Off Relay		On/Off		ODF_ON	
Cir.A Sat.Discharge Temp		xxx.x	°F	SDT_A	
Cir.A Sat.Suction Temp		xxx.x	°F	SST_A	
Cir.A Discharge Pressure		xxx.x	PSI	SDP_A	
Cir.A Suction Pressure	xxx.x	PSI	SSP_A		
<b>VENTDISP</b>					
	Ventilation Status	see Appendix B		VENTSTAT	
	Ventilation Status	see Appendix B		VENTTEXT	
	Min Position in Effect	0 to 100	%	MIN_POS	Forcible
	In Pre-Occupancy Purge?	Yes/No		PREOCCON	
	Differential Air Quality	-5000 to 5000	PPM	AQ_DIFF	
	IDF Commanded RPM	0 to 3000	RPM	FSPD_RPM	
	Econo Commanded Position	0 to 100	%	DAMPCMD	Forcible
	Damper Actual Position	0 to 100	%	DAMPPOS	
	Free Cooling active	Yes/No		FREECOOL	
	Currently Occupied	Yes/No		OCCUPIED	Forcible
	Mins until next occupied	-1 to 10080	min	MINTILOC	
	Ok to Preoccupancy Purge	Yes/No		OKPREOCC	
	Power Exhaust 1 Relay	On/Off		PE1	Forcible
	Power Exhaust 2 Relay	On/Off		PE2	Forcible
	2-Pos Damper/ERV relay	On/Off		ERV_2POS	



**APPENDIX D — SYSTEMVU™ CONTROLLER CCN TABLES**

**STATUS DISPLAY TABLES (CONT)**

TABLE	DISPLAY NAME	VALUES	UNITS	POINT NAME	WRITE STATUS
<b>ALRMDISP</b>	Active Alarm 1 Code	xxx		ALMCODE1	
	Active Alarm 2 Code	xxx		ALMCODE2	
	Active Alarm 3 Code	xxx		ALMCODE3	
	Active Alarm 4 Code	xxx		ALMCODE4	
	Active Alarm 5 Code	xxx		ALMCODE5	
	Reset All Current Alarms	Yes/No		ALRESET	Writable
<b>STRTHOUR</b>	Compressor A1 Run Hours	xxxxxx.x	hrs	HR_A1	
	CMP A1 Loader Run Hours	xxxxxx.x	hrs	HR_ALDR	
	Alarm Relay Run Hours	xxxxxx.x	hrs	HR_ALM	
	CCH1 Relay Run Hours	xxxxxx.x	hrs	HR_CCHR1	
	Econ Damper Run Hours	xxxxxx.x	hrs	HR_DAMP	
	2Position/ERV Run Hours	xxxxxx.x	hrs	HR_ERV2P	
	Unit Full Load Run Hours	xxxxxx.x	hrs	HR_FLOAD	
	Free Cooling Run Hours	xxxxxx.x	hrs	HR_FREEC	
	Heat Stage 1 Run Hours	xxxxxx.x	hrs	HR_HTR_1	
	Heat Stage 2 Run Hours	xxxxxx.x	hrs	HR_HTR_2	
	Indoor Fan Run Hours	xxxxxx.x	hrs	HR_IDF	
	Defrost Run Hours	xxxxxx.x	hrs	HR_DFRST	
	LiquidLineValv Run Hours	xxxxxx.x	hrs	HR_LLSV	
	Max Fan Speed Run Hours	xxxxxx.x	hrs	HR_MAXF	
	MechanicalCool Run Hours	xxxxxx.x	hrs	HR_MECHC	
	MechanicalHeat Run Hours	xxxxxx.x	hrs	HR_MECHT	
	ODF Run Hours	xxxxxx.x	hrs	HR_ODF	
	ODF Relay Run Hours	xxxxxx.x	hrs	HR_OFR	
	ReverseSolValv Run Hours	xxxxxx.x	hrs	HR_RVS_A	
	Power Exhaust1 Run Hours	xxxxxx.x	hrs	HR_PE_1	
	Power Exhaust2 Run Hours	xxxxxx.x	hrs	HR_PE_2	
	Service Test Run Hours	xxxxxx.x	hrs	HR_STEST	
	Vent IDF Run Hours	xxxxxx.x	hrs	HR_VENTF	
<b>STRTCNTS</b>	Compressor A1 Starts	xxxxxx		ST_A1	
	CMP A1 Loader Starts	xxxxxx		ST_ALDR	
	Alarm Relay Starts	xxxxxx		ST_ALM	
	Alarm Reset Counts	xxxxxx		ST_ALRST	
	CCH1 Relay Starts	xxxxxx		ST_CCHR1	
	Economizer Damper Starts	xxxxxx		ST_DAMP	
	2Position/ERV Starts	xxxxxx		ST_ERV2P	
	Unit Full Load Starts	xxxxxx		ST_FLOAD	
	Free Cooling Starts	xxxxxx		ST_FREEC	
	Heat Stage 1 Starts	xxxxxx		ST_HTR_1	
	Heat Stage 2 Starts	xxxxxx		ST_HTR_2	
	Indoor Fan Starts	xxxxxx		ST_IDF	
	Defrost Mode Starts	xxxxxx		ST_DFRST	
	Liquid Line Valve Starts	xxxxxx		ST_LLSV	
	Max IDF Speed Starts	xxxxxx		ST_MAXF	
	Mechanical Cool Starts	xxxxxx		ST_MECHC	
	Mechanical Heat Starts	xxxxxx		ST_MECHT	
	ODF Starts Count	xxxxxx		ST_ODF	
	ODF Relay Starts	xxxxxx		ST_OFR	
	Power Exhaust 1 Starts	xxxxxx		ST_PE_1	
	Power Exhaust 2 Starts	xxxxxx		ST_PE_2	
	Power Cycle Counts	xxxxxx		ST_POR	
	ReverseSolValv Starts	xxxxxx		ST_RVS_A	
Service Test Starts	xxxxxx		ST_STEST		
Ventilation Fan Starts	xxxxxx		ST_VENTF		

**APPENDIX D — SYSTEMVU™ CONTROLLER CCN TABLES**

**STATUS DISPLAY TABLES (CONT)**

TABLE	DISPLAY NAME	VALUES	UNITS	POINT NAME	WRITE STATUS
STRTRSTS	Comp A1 Resets Count	xxxxxx		RS_A1	
	A1 Loader Resets Count	xxxxxx		RS_ALDR	
	Alarm Relay Resets Count	xxxxxx		RS_ALM	
	Alarm Reset Resets Count	xxxxxx		RS_ALRST	
	CCH1 Relay Resets Count	xxxxxx		RS_CCHR1	
	Econ Damper Resets Count	xxxxxx		RS_DAMP	
	2Position/ERV ResetCount	xxxxxx		RS_ERV2P	
	Full Load Resets Count	xxxxxx		RS_FLOAD	
	Free Cooling Reset Count	xxxxxx		RS_FREEC	
	Heat Stage 1 Reset Count	xxxxxx		RS_HTR_1	
	Heat Stage 2 Reset Count	xxxxxx		RS_HTR_2	
	Indoor Fan Reset Count	xxxxxx		RS_IDF	
	Defrost Reset Count	xxxxxx		RS_DFRST	
	LiquidLineValv Reset Cnt	xxxxxx		RS_LLSV	
	Max IDF Spd Resets Count	xxxxxx		RS_MAXF	
	Mech Cool Reset Count	xxxxxx		RS_MECHC	
	Mech Heat Reset Count	xxxxxx		RS_MECHT	
	ODF Resets Count	xxxxxx		RS_ODF	
	ODF Relay Resets Counts	xxxxxx		RS_OFR	
	P.Exhaust 1 Resets Count	xxxxxx		RS_PE_1	
	P.Exhaust 2 Resets Count	xxxxxx		RS_PE_2	
	Power Cycle Resets Count	xxxxxx		RS_POR	
	RevSolValv Reset Count	xxxxxx		RS_RVS_A	
	Reheat lev 1 Rst Count	xxxxxx		RS_RQHL1	
	Reheat lev 2 Rst Count	xxxxxx		RS_RQHL2	
	Service Test Reset Count	xxxxxx		RS_STEST	
	Vent IDF Resets Count	xxxxxx		RS_VENTF	

## APPENDIX D — SYSTEMVU™ CONTROLLER CCN TABLES

### MAINTENANCE TABLES

TABLE	DISPLAY NAME	VALUES	UNITS	POINT NAME	WRITE STATUS
<b>MODES</b>	Operating Mode	see Appendix B		MODETEXT	
	System Mode	see Appendix B		SYSMODE	
	Operating Sub-Mode	see Appendix B		SUBMTEXT	
	Running Mode Operation	see Appendix B		SUB_MODE	
	Ventilation Status	see Appendix B		VENTTEXT	
	Ventilation Status	see Appendix B		VENTSTAT	
	System Demand	see Appendix B		SYS_DMDT	
	System Demand	0 to 99		SYS_DMD	
	Currently Occupied	Yes/No		OCCUPIED	Forcible
	Linkage Active	Yes/No		LNK_ACT	
	Unocc Free Cool Active	Yes/No		UFC_ACT	
	Temp Compensate Start On	Yes/No		TCS_ACT	
	Current Mode Ended	Yes/No		MODEDONE	
	Cool Mode Select T.guard	xxx	sec	COOLMSTG	
	Heat Mode Select T.guard	xxx	sec	HEATMSTG	
	Cool Setpoint in Effect	xx.x	°F	CSP_EFF	
	Heat Setpoint in Effect	xx.x	°F	HSP_EFF	
	Effective Demand Temp	xxx.x	°F	TEMP_EFF	
	Space Cooling Demand	xx.x	ΔF	COOL_DMD	
	Cooling Demand Trend	xx.x		CLDTREND	
Heating Space Demand	xx.x	ΔF	HEAT_DMD		
Heat Space Demand Trend	xx.x		HTDTREND		
<b>TESTMODE</b>	Economizer Position Test	0 to 100	%	S_DAMPER	Writable
	Compressor Bump A1 Test	On/Off		S_BMPA1	Writable
	Rev.Val. Sole. Cir.A Tst	On/Off		S_RVS_A	Writable
	LiqLine Solenoid Test	On/Off		S_LLSV	Writable
	Crankcase Heater 1 test	On/Off		S_CCHR1	Writable
	Alarm Output Relay Test	On/Off		S_ALARM	Writable
	Power Exhaust 1 Test	On/Off		S_PE_1	Writable
	Power Exhaust 2 Test	On/Off		S_PE_2	Writable
	2Position/ERV Relay Test	On/Off		S_ERV2P	Writable
	Econ Damper Calibration	On/Off		S_ECOCAL	Writable
	Indoor Fan Speed Test	0 to 100	%	S_IDFSPD	Writable
	IDF Manual Transition	Yes/No		S_IDFTRN	Writable
	Cooling W/Comp.A1 Test	On/Off		S_COOLA1	Writable
	Cooling W/Comp.ALD Test	On/Off		S_COLALD	Writable
	ODF On/Off Relay Test	On/Off		S_ODFON	Writable
	ODF Speed Relay Test	On/Off		S_OFRSPD	Writable
	Heating Stage 1 Test	On/Off		S_HEAT1	Writable
	Heating Stage 2 Test	On/Off		S_HEAT2	Writable
	Mechanical Heating Test	On/Off		S_MECHT	Writable
Defrost Test	On/Off		S_DFRST	Writable	
AUTO INDEPENDENT TEST	Yes/No		AUTOINDP	Writable	
RUN AUTO COOLING TEST	Yes/No		AUTOCOOL	Writable	
RUN AUTO HEATING TEST	Yes/No		AUTOHEAT	Writable	
RUN AUTO SYSTEM TEST	Yes/No		AUTOSYS	Writable	
<b>IDF_DIAG</b>	IDF Commanded RPM	0 to 3000	RPM	FSPD_RPM	
	Commanded IDF Speed	0 to 100	%	FANSPEED	
	Requested IDF Speed	0 to 100	%	RQFANSPD	
	IDF Vent Speed-RPM	0 to 3000	RPM	RPM_VENT	
IDF Heat Speed-RPM	0 to 3000	RPM	RPM_HEAT		

**APPENDIX D — SYSTEMVU™ CONTROLLER CCN TABLES**

**MAINTENANCE TABLES (CONT)**

TABLE	DISPLAY NAME	VALUES	UNITS	POINT NAME	WRITE STATUS	
<b>IDF_DIAG (cont)</b>	IDF Free Cool Speed-RPM	0 to 3000	RPM	RPM_FCL		
	IDF Low Cool Speed-RPM	0 to 3000	RPM	RPM_LCL		
	IDF High Cool Speed-RPM	0 to 3000	RPM	RPM_HCL		
	IDF Maximum Fan Speed	0 to 100	%	SPEEDMAX		
	Fan Status Switch	On/Off		FAN_STAT		
	IDF Manual Limit Switch	Open/Close		IDF_LSM		
	IDF Speed Override Flag	On/Off		FAN_OVRD		
	IDF Speed Reduction On	Yes/No		FANRED10		
	IDF Operation Errors?	Yes/No		IDFBAD		
<b>USB_DIAG</b>	USB TREND STATUS	0=IDLE, 1=TRENDING, 2=NO POINTS, 3=USB FULL		TRNDSTAT		
	USB TREND DURATION	0=FULL, 1=ROLLING, 2=LASTWEEK, 3=1 MINUTE, 4=5 MINUTES, 5=15 MINUTES, 6=30 MINUTES, 7=1 HOUR, 8=3 HOURS, 9=8 HOURS, 10=12 HOURS, 11=1 DAY, 12=1.5 DAYS, 13=2 DAYS, 14=3 DAYS, 15=5 DAYS, 16=1 WEEK, 17=2 WEEKS, 18=4 WEEKS		TRND DUR	Writable	
	USB TREND RATE	1 to 300	sec	TRNDRATE	Writable	
	USB TREND POINTS FROM	0=FILE, 1=LIST		TRNDPNTS	Writable	
	TREND FILE SEARCH	text		TRNDFILE		
	TREND EQUIP PERFORMANCE	On/Off		TRNDEQPR	Writable	
	TREND COOL PERFORMANCE	On/Off		TRNDCLPR	Writable	
	TREND HEAT PERFORMANCE	On/Off		TRNDHTPR	Writable	
	Trend Cooling Diagnostic	On/Off		TRNDCLDG	Writable	
	TREND IDF DIAGNOSTIC	On/Off		TRNDIDF	Writable	
	TREND VENTILATION	On/Off		TRNDVENT	Writable	
	TREND GEN INPUTS/OUTPUTS	On/Off		TRNDIO	Writable	
	Start USB Trending	Yes/No		TREND_EN	Writable	
	Make Config Backup File	Start/Stop		DDBCKUP	Writable	
	Backup file is ready	0=IDLE, 1=SUCCESS, 2=FAILURE		BACKUP_R		
	USB Find Restore File	Yes/No		BACKFILE	Writable	
	Start Config Restore	Start/Stop		DDRSTRE	Writable	
	File Error	Yes/No		FILE_ERR		
	<b>COOLDIAG</b>	System Demand	see Appendix B		SYS_DMDT	
		Operating Sub-Mode	see Appendix B		SUBMTEXT	
IDF Commanded RPM		0 to 3000	RPM	FSPD_RPM		
OK to Use Free Cooling?		Yes/No		OKFREECL		
Econ Damper Operational		Yes/No		DAMPGOOD		
Dry Bulb Lockout		Yes/No		DBLOCK	Forcible	
Enthalpy Lockout		Yes/No		ENTHLOCK	Forcible	
Free Cooling active		Yes/No		FREECOOL		
Unocc Free Cool Active		Yes/No		UFC_ACT		
Free Cooling SAT Setpnt		xx.x	°F	FC_SATSP		

**APPENDIX D — SYSTEMVU™ CONTROLLER CCN TABLES**

**MAINTENANCE TABLES (CONT)**

TABLE	DISPLAY NAME	VALUES	UNITS	POINT NAME	WRITE STATUS
<b>COOLDIAG (cont)</b>	Requested Damper Pos	0 to 100	%	REQDAMP	
	Econo Commanded Position	0 to 100	%	DAMPCMD	Forcible
	Ok to use compressors?	Yes/No		OKMECHCL	
	Compressor A1 strikes	x		A1STRIKE	
	Circuit A Locked Out	Yes/No		CIRALOCK	
	Mechanical Cool active?	Yes/No		MECHCOOL	
	Max Allowed Cool Stages	0 to 3		MAXCSTGS	Forcible
	Supply Air Temp Trend	xxx.x		SATTREND	
	Supply Air Temperature	xxx..x		SAT	
	Requested Cooling Stages	0 to 3		REQCSTGS	
	Low cooling locked out	Yes/No		LC_LOCK	
	Compressor A1 Timeguard	xxx		TIMGD_A1	
	Comp A1 Loader Timeguard	xxx		TIMG_ALD	
	Compressor A1 Locked Out	Yes/No		CA1_LOCK	
	Compressor A1 Available	Yes/No		CA1_AVAL	
	Recent Comp A1 Strike	Yes/No		A1STKACT	
	Circuit A Compressor 1	On/Off		COMP_A1	
	Circuit A CMP A1 Loader	On/Off		COMP_ALD	
	Rev.Valve Solenoid Cir.A	On/Off		RVS_A	
	Actual Cool Stage Active	x		ACTCSTGS	
	ODF On/Off Relay	On/Off		ODF_ON	
	Outdoor Fan Speed Relay	On/Off		OFR	
	ODF State	0=OFF, 1=ON, 2=LOW, 3=HIGH		ODFSTATE	
	High Pressure Override	Yes/No		HP_OVR	
	Outdoor Air Temperature	xxx.x		OAT	Forcible
	Ok to use Fan Dehum	Yes/No		OKTOFBD	
	FBDH SST Lockout	Yes/No		FBDSSTLO	
	FBDH SAT Lockout	Yes/No		FBDSATLO	
	Fan Based Dehum Type	0=NONE, 1=Comfort, 2=Max		FBD_TYPE	
	FBDH Comfort SAT SP	35 to 80		FBDH_SAT	
	FBDH Max Mode SST SP	20 to 60		FBDSSTSP	
	FBDH Low Set Point	-20 to 0		FBDLO_SP	
	Cir.A High Pressure Sw	Open/Close		CIRA_HPS	
	Cir.A Discharge Pressure	xxx.x		SDP_A	
	Cir.A Suction Pressure	xxx.x		SSP_A	
	Circuit A Pressure Ratio	xx.xx		CIRA_PR	
	Cir.A Sat.Discharge Temp	xxx.x		SDT_A	
	Cir.A Sat.Suction Temp	xxx.x		SST_A	
<b>OKFCDIAG</b>					
	Outdoor Air Temperature	xxx.x	°F	OAT	Forcible
	OA Relative Humidity	0 to 100	%	OARH	Forcible
	Outdoor Air Enthalpy	-9.6 to 334.2	BTU_LB	OA_ENTH	Forcible
	Return Air Temperature	xxx.x	°F	RAT	Forcible
	RA Relative Humidity	0 to 100	%	RARH	Forcible
	Return Air Enthalpy	-9.6 to 334.2	BTU_LB	RA_ENTH	Forcible
	Barometric Pressure	xx.xx	in. Hg	BARP	Forcible
	Diff. Dry Bulb Control	Enable/Disable		DIFFBULB	
	Free Cooling Min Temp	-30 to 70	°F	MINFREET	
	Free Cooling Max OAT	0 to 90	°F	MAXFREET	
	Diff. Dry Bulb Deadband	0 to 20	°F	OATRATDB	
	Dry Bulb Lockout	Yes/No		DBLOCK	Forcible

**APPENDIX D — SYSTEMVU™ CONTROLLER CCN TABLES**

**MAINTENANCE TABLES (CONT)**

TABLE	DISPLAY NAME	VALUES	UNITS	POINT NAME	WRITE STATUS
<b>OKFCDIAG (cont)</b>	Diff. Enthalpy Control	Enable/Disable		DIFFENTH	
	Max Enthalpy OA limit	1 to 99	BTU_LB	FREEMAXE	
	Enthalpy Cross Deadband	0 to 20	BTU_LB	OAERAEDB	
	Enthalpy Switch	High/Low		ENTH_SW	Forcible
	Enthalpy Lockout	Yes/No		ENTHLOCK	Forcible
	Currently Occupied	Yes/No		OCCUPIED	Forcible
	Unocc Free Cool Low Temp	-30 to 70	°F	OATLUFC	
	Unocc Free Cool Lockout	Yes/No		UNOCLOCK	
	Econ Damper Operational	Yes/No		DAMPGOOD	
	OK to Use Free Cooling?	Yes/No		OKFREECL	
	Ok to Unocc Free Cool?	Yes/No		OKTOUFC	
	<b>HEATDIAG</b>	System Demand	see Appendix B		SYS_DMDT
Operating Sub-Mode		see Appendix B		SUBMTEXT	
IDF Commanded RPM		0 to 3000	RPM	FSPD_RPM	
OK to Run Heat		Yes/No		OKTOHEAT	
All Heat Stages Lockout		Yes/No		ALLHTLOC	Forcible
Max Allowed Heat Stages		0 to 2		MAXHSTGS	Forcible
Supply Air Temp Trend		xxx.x		SATTREND	
Supply Air Temperature		xxx..x	°F	SAT	
Requested Heating Stages		0 to 2		REQHSTGS	
Heat Stage 1 Timeguard		xxx	sec	TIMGD_H1	
Heat Stage 2 Timeguard		xxx	sec	TIMGD_H2	
Heat Stage 1 Available		Yes/No		HT1_AVAL	
Heat Stage 2 Available		Yes/No		HT2_AVAL	
Heat Stage 1 Relay		On/Off		HEAT_1	
Heat Stage 2 Relay		On/Off		HEAT_2	
Actual Heat Stage Active		x		ACTHSTGS	
Outdoor Air Temperature		xxx.x	°F	OAT	Forcible
Return Air Temperature		xxx.x	°F	RAT	Forcible
Fan Supply Air Temp		xxx.x	°F	FST	
Econo Commanded Position		0 to 100	%	DAMPCMD	Forcible
Defrost Mode Timer		xxxx	sec	DF_TIMER	
Defrost Interval Timer		xxxx	sec	DFINT_T	
Defrost Mode Active		Yes/No		DFRSTACT	
Heat2 delay timer		xxx	sec	H2DLTMR	
Mechanical Heating		Yes/No		MECHT_EN	
ODF State		0=OFF, 1=ON, 2=LOW, 3=HIGH		ODFSTATE	
Compressor A1 Timeguard		xxx	sec	TIMGD_A1	
Comp A1 Loader Timeguard		xxx	sec	TIMG_ALD	
Supply Air Temp Trend		xxx.x		SATTREND	
Compressor A1 strikes		x		A1STRIKE	
Circuit A Locked Out		Yes/No		CIRALOCK	
Compressor A1 Available		Yes/No		CA1_AVAL	
Compressor A1 Locked Out	Yes/No		CA1_LOCK		
<b>PE_DIAG</b>	0 = None				
	1 = MBB RLY11				
	2 = MBB RLY06				
	PE1 Relay Channel	0 to 2		PE1_CHAN	
	PE2 Relay Channel	0 to 2		PE2_CHAN	

**APPENDIX D — SYSTEMVU™ CONTROLLER CCN TABLES**

**MAINTENANCE TABLES (CONT)**

TABLE	DISPLAY NAME	VALUES	UNITS	POINT NAME	WRITE STATUS	
<b>PE_DIAG (cont)</b>	PE Turn Off Dead band	0 to 100	%	PE_OFFDB		
	Power Exhaust 1 Relay	On/Off		PE1	Forcible	
	Power Exhaust 2 Relay	On/Off		PE2	Forcible	
	Econo Commanded Position	0 to 100	%	DAMPCMD	Forcible	
	IDF Commanded RPM	0 to 3000	RPM	FSPD_RPM		
	IDF Maximum Fan Speed	0 to 100	%	SPEEDMAX		
	P.Exhaust 1 Curve Offset	0 to 100	%	PE1_OFFS		
	P.Exhaust 2 Curve Offset	0 to 100	%	PE2_OFFS		
	Power Exhaust 1 - Speed1	0 to 100	%	PE1_SPD1		
	Power Exhaust 1 - Speed2	0 to 100	%	PE1_SPD2		
	Power Exhaust 1 - Speed3	0 to 100	%	PE1_SPD3		
	PE Stage 1 At Max Speed	0 to 100	%	PE1_PMAX		
	Power Exhaust 1 - Pos 1	0 to 100	%	PE1_POS1		
	Power Exhaust 1 - Pos 2	0 to 100	%	PE1_POS2		
	Power Exhaust 1 - Pos 3	0 to 100	%	PE1_POS3		
	Power Exhaust 2 - Speed1	0 to 100	%	PE2_SPD1		
	Power Exhaust 2 - Speed2	0 to 100	%	PE2_SPD2		
	Power Exhaust 2 - Speed3	0 to 100	%	PE2_SPD3		
	PE Stage 2 At Max Speed	0 to 100	%	PE2_PMAX		
	Power Exhaust 2 - Pos 1	0 to 100	%	PE2_POS1		
	Power Exhaust 2 - Pos 2	0 to 100	%	PE2_POS2		
	Power Exhaust 2 - Pos 3	0 to 100	%	PE2_POS3		
	<b>VENTDIAG</b>	Operating Sub-Mode	see Appendix B		SUBMTEXT	
		Ventilation Status	see Appendix B		VENTTEXT	
		Ventilation Status	see Appendix B		VENTSTAT	
		Currently Occupied	Yes/No		OCCUPIED	Forcible
		Mins until next occupied	-1 to 10080	min	MINTILOC	
		Fan On When Occupied	Yes/No		FANON_OC	
IDF Commanded RPM		0 to 3000	RPM	FSPD_RPM		
Free Cooling active		Yes/No		FREECOOL		
Min Position in Effect		0 to 100	%	MIN_POS	Forcible	
Requested Damper Pos		0 to 100	%	REQDAMP		
Econo Commanded Position		0 to 100	%	DAMPCMD	Forcible	
Damper Actual Position		0 to 100	%	DAMPPOS		
Analog Input IAQ Control		0=NO IAQ, 1=DCV, 2=IAQ OVRD, 3=CTRL MINP		IAQANCFG		
Indoor Air Quality Level		xxxx	PPM	IAQ	Forcible	
OA Quality Level		xxxx	PPM	OAQ	Forcible	
Differential Air Quality		-5000 to 5000	PPM	AQ_DIFF		
AQ Differential High		0 to 5000		DAQ_HIGH		
AQ Differential Low		0 to 5000		DAQ_LOW		
AQ Diff High IAQOVERRIDE		0 to 5000	PPM	AQD_HIGH		
AQ Diff Low-IAQ OVERRIDE		0 to 5000	PPM	AQD_LOW		
IAQ override enable		Yes/No		IAQOVREN		
IAQ Preoccupancy Purge		Yes/No		IAQPURGE		
Preocc Purge Lockout OAT		0 to 70	°F	IAQP_LA		
Ok to Preoccupancy Purge		Yes/No		OKPREOCC		
Preocc Purge Duration		5 to 120	min	IAQPTIME		
In Pre-Occupancy Purge?		Yes/No		PREOCCON		
Is IAQ Override Active?		Yes/No		IAQ_OVRD		
IAQ Override Switch		On/Off		IAQ_OVRS	Forcible	

**APPENDIX D — SYSTEMVU™ CONTROLLER CCN TABLES**

**MAINTENANCE TABLES (CONT)**

TABLE	DISPLAY NAME	VALUES	UNITS	POINT NAME	WRITE STATUS
<b>VENTDIAG (cont)</b>	2-Pos Damper/ERV Channel	0=NONE, 1=MBB RLY11, 2=MBB RLY06		EV2PCHAN	
	Supply Air Temperature	xxx..x	°F	SAT	
	Return Air Temperature	xxx.x	°F	RAT	Forcible
	Outdoor Air Temperature	xxx.x	°F	OAT	Forcible
	Damper SAT deadband	0 to 20	°F	T24SATDB	
	T24 Min Diff in RAT-OAT	5 to 20	°F	T24RATDF	
	T24 Heat/Cool End Delay	0 to 60	min	T24CHDLY	
	SAT heat mode sensing	Enable/Disable		SAT_HEAT	
	Actual Heat Stage Active	x		ACTHSTGS	
	Actual Cool Stage Active	x		ACTCSTGS	
	OK to Use Free Cooling?	Yes/No		OKFREECL	
	T24 Test Minimum Pos	0 to 100	%	T24TSTMN	
	Econo Commanded Position	0 to 100	%	DAMPCMD	Forcible
	T24 Test Maximum Pos	0 to 100	%	T24TSTMX	
	T24Econ Min Move for SAT	10 to 20	%	T24ECSTS	
	Damper Actual Position	0 to 100	%	DAMPPPOS	
	<b>VENTCURV</b>				
Econ Min at Max Fanspeed		0 to 100	%	MINP_MAX	
IDF Maximum Fan Speed		0 to 100	%	SPEEDMAX	
Min Pos - User Pos 1		0 to 100	%	MP_UPOS1	
Min Pos - User Pos 2		0 to 100	%	MP_UPOS2	
Min Pos - User Pos 3		0 to 100	%	MP_UPOS3	
Min Pos - User Speed 1		0 to 100	%	MP_USPD1	
Min Pos - User Speed 2		0 to 100	%	MP_USPD2	
Min Pos - User Speed 3		0 to 100	%	MP_USPD3	
User Min Pos Pnt 1 Valid		Yes/No		MP_UPT1	
User Min Pos Pnt 2 Valid		Yes/No		MP_UPT2	
User Min Pos Pnt 3 Valid		Yes/No		MP_UPT3	
Min Pos - Default Pos 1		0 to 100	%	MP_DPOS1	
Min Pos - Default Pos 2		0 to 100	%	MP_DPOS2	
Min Pos - Default Pos 3		0 to 100	%	MP_DPOS3	
Min Pos - Default Speed1		0 to 100	%	MP_DSPD1	
Min Pos - Default Speed2		0 to 100	%	MP_DSPD2	
Min Pos - Default Speed3		0 to 100	%	MP_DSPD3	
Min Pos Curve - Pos 1		0 to 100	%	MP_POS1	
Min Pos Curve - Pos 2		0 to 100	%	MP_POS2	
Min Pos Curve - Pos 3		0 to 100	%	MP_POS3	
Min Pos Curve - Speed 1		0 to 100	%	MP_SPD1	
Min Pos Curve - Speed 2		0 to 100	%	MP_SPD2	
Min Pos Curve - Speed 3		0 to 100	%	MP_SPD3	
IAQ DCV Curve Offset		0 to 100	%	IAQ_OFFS	
IAQ Position at Max Fan		0 to 100	%	IAQMINP	
IAQ DCV Curve - Pos 1		0 to 100	%	AQ_POS1	
IAQ DCV Curve - Pos 2		0 to 100	%	AQ_POS2	
IAQ DCV Curve - Pos 3		0 to 100	%	AQ_POS3	
IAQ DCV Curve - Speed 1	0 to 100	%	AQ_SPD1		
IAQ DCV Curve - Speed 2	0 to 100	%	AQ_SPD2		
IAQ DCV Curve - Speed 3	0 to 100	%	AQ_SPD3		
IAQ Purge Curve Offset	0 to 100	%	AQP_OFFS		
IAQ Purge Pos at Max IDF	0 to 100	%	IAQPMAX		
IAQ Purge Curve - Pos 1	0 to 100	%	AQP_POS1		



**APPENDIX D — SYSTEMVU™ CONTROLLER CCN TABLES**

**MAINTENANCE TABLES (CONT)**

TABLE	DISPLAY NAME	VALUES	UNITS	POINT NAME	WRITE STATUS
<b>VENTCURV (cont)</b>	IAQ Purge Curve - Pos 2	0 to 100	%	AQP_POS2	
	IAQ Purge Curve - Pos 3	0 to 100	%	AQP_POS3	
	IAQ Purge Curve - Speed1	0 to 100	%	AQP_SPD1	
	IAQ Purge Curve - Speed2	0 to 100	%	AQP_SPD2	
	IAQ Purge Curve - Speed3	0 to 100	%	AQP_SPD3	
<b>LINKDATA</b>	Linkage CCN element #	xxx		LNK_SUPE	Forcible
	Linkage CCN Bus number	xxx		LNK_SUPB	Forcible
	Block No: in Master Zone	1 to 8		LNK_MZBK	Forcible
	Average Occup. Heat Stp.	xxx.x	°F	LNK_OHSP	Forcible
	Average Occup. Cool Stp.	xxx.x	°F	LNK_OCSP	Forcible
	Average Unocc. Heat Stp.	xxx.x	°F	LNK_UHSP	Forcible
	Average Unocc. Cool Stp.	xxx.x	°F	LNK_UCSP	Forcible
	Average Zone Temperature	xxx.x	°F	LNK_AZT	Forcible
	Average Occup. Zone Temp	xxx.x	°F	LNK_AOZT	Forcible
	Linkage Occupied Request	0 to 2		LNK_OCC	Forcible
	0 = Unoccupied				
	1 = Occupied				
	2 = Disabled				
	Linkage Next Occ Day			LNEXTOCD	
	Linkage Next Occ Time			LNEXTOCT	
	Linkage Last Unocc Day			LNEXTUOD	
	Linkage Next Unocc Time			LNEXTUCT	
	Linkage Last Unocc Day			LLASTUOD	
	Linkage Last Unocc Time			LLASTUCT	
	Linkage Active	Yes/No		LNK_ACT	
	Linkage Equipment Mode	1 to 8		LNK_MODE	Forcible
	Linkage Start Bias time	xxx	min	LNK_SBT	Forcible
	Value of Prime variable	xxx.x		PRIME_V	
<b>OCC_DIAG</b>	Currently Occupied	Yes/No		OCCUPIED	Forcible
	Active Occupancy control	0 to 6		OCC_CTRL	
	0 = 24/7 OCC				
	1 = Schedule				
	2 = BAS CTRL				
	3 = REMOC CTL				
	4 = Time Override				
	5 = Linkage				
	6 = Forced				
	Linkage Occupied Request	0=Unocc, 1=Occupied, 2=Disabled		LNK_OCC	Forcible
	Timed Override Hours	0 to 240	min	OVR_EXT	Forcible
	Remote Occupancy Switch	On/Off		REMOCC	Forcible
	BMS Occupancy Request	0 to 2		BMS_OCC	Forcible
	0 = Unoccupied				
	1 = Occupied				
	2 = Disabled				
	Local Sched Occ Request	0 to 1		LOC_OCC	Forcible
	0 = Unoccupied				
	1 = Occupied				
	Active Schedule period	0 to 8		PER_NO	
	Mins until next occupied	-1 to 10080	min	MINTILOC	
	BACnetCal Object Status			CALOBJST	
	Today Is A Holiday	Yes/No		HOLTODAY	
Tomorrow Is A Holiday	Yes/No		HOL_TMRW		
Next Occupied Day	DDD		NXTOCDAY		
Next Occupied Time	hh:mm	min	NXTOCTIM		
Next Unoccupied Day	DDD		NXTUNDAY		

**APPENDIX D — SYSTEMVU™ CONTROLLER CCN TABLES**

**MAINTENANCE TABLES (CONT)**

TABLE	DISPLAY NAME	VALUES	UNITS	POINT NAME	WRITE STATUS	
<b>OCC_DIAG (cont)</b>	Next Unoccupied Time	hh:mm	min	NXTUNTIM		
	Previous Unoccupied Day	DDD		PRVUNDAY		
	Previous Unoccupied Time	hh:mm	min	PRVUNTIM		
	Accept Global Holidays?	Yes/No		HOLIDAYT		
	Global Schedule Broadcst	Yes/No		CCN_GSBC		
	CCN Schedule Number	0 to 99		SCHEDNUM		
	0 = Always Occupied					
	1-64 = Local Schedule					
	65-99 = Global Schedule					
	Remote Occupancy Channel	0=None, 1=MBB DI12, 2=MBB DI13, 3=MBB DI14, 4=MBB DI02, 5=MBB Y3			RMOCCCHAN	
	Remote Occupancy Switch	On/Off			REMOCC	Forcible
	Timed Override Duration	0 to 4	hrs		OTL_CFG	
	BAS Protocol Select	0=NONE, 1=CCN, 2=BACNET			BMS_CFG	
	<b>HW_IO</b>	0 = None				
		1 = IAQ				
2 = OARH						
3 = RARH						
4 = OAQ						
5 = SPRH						
6 = OACFM						
Assigned AI06 Function		0 to 6			MBBAI06F	
Assigned AI07 Function		0 to 6			MBBAI07F	
Assigned AI08 Function		0 to 6			MBBAI08F	
0 = None						
1 = COFS						
2 = REMOCC						
3 = REMOFF						
4 = FILTER						
5 = ENTHALPY						
6 = GEN STAT						
7 = HUMSTAT						
8 = IAQOVRD						
9 = SMK EVAC						
10 = SMK PRESS						
11 = SMK PURGE						
12 = FIREDOWN						
13 = FANSTATUS						
14 = PHASEMON						
Assigned DI02 Function		0 to 10			MBBDI02F	
Assigned DI03 Function		0 to 10			MBBDI03F	
Assigned MBB Y3 Function		0 to 10			MBBDI09F	
Assigned DI12 Function		0 to 10			MBBDI12F	
Assigned DI13 Function		0 to 10			MBBDI13F	
Assigned DI14 Function		0 to 10			MBBDI14F	
0 = None						
1 = Alarm Relay						
2 = PE1						
3 = PE2						
Assigned Rly 06 Function	0 to 3			MBBRY06F		
Assigned Rly 11 Function	0 to 3			MBBRY11F		

## APPENDIX D — SYSTEMVU™ CONTROLLER CCN TABLES

### MAINTENANCE TABLES (CONT)

TABLE	DISPLAY NAME	VALUES	UNITS	POINT NAME	WRITE STATUS
<b>HW_IO (cont)</b>	Outdoor Air Temp Sensor	xxx.x	°F	OAT_LOC	
	Return Air Temp Sensor	xxx.x	°F	RAT_LOC	
	Space Temperature Sensor	xxx.x	°F	SPT_LOC	
	SPRH Sensor Value	0 to 100	%	SPRH_LOC	
	Local Space Temp Offset	xxxx	ΔF	SPTO_LOC	
	OARH Sensor Value	0 to 100	%	OARH_LOC	
	RARH Sensor Value	0 to 100	%	RARH_LOC	
	IAQ Sensor value	xxxx	PPM	IAQ_LOC	
	OAQ Sensor Value	xxxx	PPM	OAQ_LOC	
	OACFM Sensor value	xxx.x	CFM	OACFM_LOC	
	Equipment Model number	xxxxxxxxxxxxxxxxxxx		EQ_MOD	
	Equipment Serial number	xxxxxxxxxx		EQ_SER	
	Application SW Version	CESR131690-01-xx		FW_CESR	
	Bootloader SW Version	CESR131659-01-xx		BL_CESR	
	MBB Part Number	CEPL131117-xx-R		BD_CEPL	
	MBB Program Part Number	CEPP130644-xx-xx-xx-R		BD_CEPP	
	Base Board serial number	xxxxMxxxxx		BD_SER	
<b>ZSENSORS</b>	Zone Sensor Temp Out	0	°F	ZSZT	
	Zone Sensor 1 Temp	0	°F	ZS1ZT	
	ZS2 Temperature	0	°F	ZS2ZT	
	ZS3 Temperature	0	°F	ZS3ZT	
	ZS4 Temperature	0	°F	ZS4ZT	
	ZS5 Temperature	0	°F	ZS5ZT	
	Zone Sensor Humidity Out	0	%	ZSSPRH	
	ZS1 Humidity	0	%	ZS1ZHUM	
	ZS2 Humidity	0	%	ZS2ZHUM	
	ZS3 Humidity	0	%	ZS3ZHUM	
	ZS4 Humidity	0	%	ZS4ZHUM	
	ZS5 Humidity	0	%	ZS5ZHUM	
	ZS Override time remain	0	min	ZSOTR	
	ZS1 Override time remain	0	min	ZS1OTR	
	ZS2 Override time remain	0	min	ZS2OTR	
	ZS3 Override time remain	0	min	ZS3OTR	
	ZS4 Override time remain	0	min	ZS4OTR	
	ZS5 Override time remain	0	min	ZS5OTR	
	ZS Setpoint OffsetOutput	0	°F delta	ZSSPTO	
	ZS1 cool setpoint offset	0	°F delta	ZS1CSOFF	
	ZS2 cool setpoint offset	0	°F delta	ZS2CSOFF	
	ZS3 cool setpoint offset	0	°F delta	ZS3CSOFF	
	ZS4 cool setpoint offset	0	°F delta	ZS4CSOFF	
	ZS5 cool setpoint offset	0	°F delta	ZS5CSOFF	
	ZS1 Heat Setpoint Offset	0	°F delta	ZS1HSOFF	
ZS2 Heat Setpoint Offset	0	°F delta	ZS2HSOFF		
ZS3 Heat Setpoint Offset	0	°F delta	ZS3HSOFF		
ZS4 Heat Setpoint Offset	0	°F delta	ZS4HSOFF		
ZS5 Heat Setpoint Offset	0	°F delta	ZS5HSOFF		
<b>USER_INS</b>	Supply Voltage Leg 1	xxx	volts	L1VOLTS	Writable
	Supply Voltage Leg 2	xxx	volts	L2VOLTS	Writable
	Supply Voltage Leg 3	xxx	volts	L3VOLTS	Writable
	Comp A1 Amps Leg 1	0 to 100	Amps	CA1L1_A	Writable
	Comp A1 Amps Leg 2	0 to 100	Amps	CA1L2_A	Writable
	Comp A1 Amps Leg 3	0 to 100	Amps	CA1L3_A	Writable
	Elec. Heat Amps Leg 1	0 to 100	Amps	EHTL1_A	Writable
	Elec. Heat Amps Leg 2	0 to 100	Amps	EHTL2_A	Writable
	Elec. Heat Amps Leg 3	0 to 100	Amps	EHTL3_A	Writable

**APPENDIX D — SYSTEMVU™ CONTROLLER CCN TABLES**

**MAINTENANCE TABLES (CONT)**

TABLE	DISPLAY NAME	VALUES	UNITS	POINT NAME	WRITE STATUS
<b>POWRESET</b>	Power Reset Event 00	mm/dd/yy, hh:mm:ss		POWRES00	
	Power Reset Event 01	mm/dd/yy, hh:mm:ss		POWRES01	
	Power Reset Event 02	mm/dd/yy, hh:mm:ss		POWRES02	
	Power Reset Event 03	mm/dd/yy, hh:mm:ss		POWRES03	
	Power Reset Event 04	mm/dd/yy, hh:mm:ss		POWRES04	
	Power Reset Event 05	mm/dd/yy, hh:mm:ss		POWRES05	
	Power Reset Event 06	mm/dd/yy, hh:mm:ss		POWRES06	
	Power Reset Event 07	mm/dd/yy, hh:mm:ss		POWRES07	
	Power Reset Event 08	mm/dd/yy, hh:mm:ss		POWRES08	
	Power Reset Event 09	mm/dd/yy, hh:mm:ss		POWRES09	
<b>ALRESET1</b>	Alarm Reset Event 00	mm/dd/yy, hh:mm:ss		ALMRES00	
	Alarm Reset Event 01	mm/dd/yy, hh:mm:ss		ALMRES01	
	Alarm Reset Event 02	mm/dd/yy, hh:mm:ss		ALMRES02	
	Alarm Reset Event 03	mm/dd/yy, hh:mm:ss		ALMRES03	
	Alarm Reset Event 04	mm/dd/yy, hh:mm:ss		ALMRES04	
	Alarm Reset Event 05	mm/dd/yy, hh:mm:ss		ALMRES05	
	Alarm Reset Event 06	mm/dd/yy, hh:mm:ss		ALMRES06	
	Alarm Reset Event 07	mm/dd/yy, hh:mm:ss		ALMRES07	
	Alarm Reset Event 08	mm/dd/yy, hh:mm:ss		ALMRES08	
	Alarm Reset Event 09	mm/dd/yy, hh:mm:ss		ALMRES09	
<b>ALRESET2</b>	Alarm Reset Event 10	mm/dd/yy, hh:mm:ss		ALMRES10	
	Alarm Reset Event 11	mm/dd/yy, hh:mm:ss		ALMRES11	
	Alarm Reset Event 12	mm/dd/yy, hh:mm:ss		ALMRES12	
	Alarm Reset Event 13	mm/dd/yy, hh:mm:ss		ALMRES13	
	Alarm Reset Event 14	mm/dd/yy, hh:mm:ss		ALMRES14	
	Alarm Reset Event 15	mm/dd/yy, hh:mm:ss		ALMRES15	
	Alarm Reset Event 16	mm/dd/yy, hh:mm:ss		ALMRES16	
	Alarm Reset Event 17	mm/dd/yy, hh:mm:ss		ALMRES17	
	Alarm Reset Event 18	mm/dd/yy, hh:mm:ss		ALMRES18	
	Alarm Reset Event 19	mm/dd/yy, hh:mm:ss		ALMRES19	
<b>TOUCH</b>	Equip Sys Touch Active			ETST_ACT	
	Equipment Touch SPT		°F	ETSPT	
	Equipment Touch RH		%	ETSPRH	
	System Touch Temp Value		°F	STST_NET	
	System Touch SPRH Value		%	STRH_NET	
	ET ST Aggregated SPT		°F	ETSTSPT	
	ET ST Aggregated SPRH		%	ETSTSPRH	

**APPENDIX D — SYSTEMVU™ CONTROLLER CCN TABLES**

**SERVICE CONFIG TABLES**

TABLE	DISPLAY NAME	VALUES	UNITS	POINT NAME	DEFAULT
<b>UNIT_CFG</b>	Unit Startup Delay	10 to 600	sec	STARTDLY	30
	Unit Control Type	0 to 2		CTRLTYPE	0 = TSTAT
	0 = Thermostat				
	1 = Space Sensor				
	2 = RAT Control				
	Thermostat Hardware Type	0 to 3		STATTYPE	0 = CONV 2C2H
	0 = 2 Stage Conventional				
	1 = 2 Stage Digital				
	2 = 3 Stage Conventional				
	3 = 3 Stage Digital				
	Ventilation Method	0 to 4194303		VENTTYPE	0: No FIOF 1: Economizer FIOF 2: Two Position Damper FIOF
	0 = None				
	1 = Economizer				
	2 = 2-Position Damper				
	3 = ERV				
	4 = Economizing ERV				
	2-Pos Damper/ERV Channel	0 to 2		EV2PCHAN	0: No FIOF 2: FIOF
	0 = None				
	1 = MBB RLY11				
	2 = MBB RLY06				
	Tstat Adaptive Staging	Yes/No		ADPTSTAT	Yes
	Change Filter Timer	0 to 9999	hrs	FILT LIFE	0
	Test Inactivity Time Out	0 to 6		TEST_ITO	4
	0 = Disabled				
	1 = 30 Minutes				
	2 = 1 Hour				
	3 = 2 Hours				
	4 = 4 Hours				
	5 = 8 Hours				
	6 = 12 Hours				
	CCH Max Temperature	40 to 90	°F	CCHMAXT	65
	Std Barometric Pressure	13 to 35	"Hg	STD_BARP	29.92
	Linkage Stage inc. time	60 to 600	sec	LSTAGINC	180
	Unit's Maximum SAT	130 to 210	°F	UMAX_SAT	200
	Unit's Minimum SAT	30 to 70	°F	UMIN_SAT	32
	Auto Clr SAT Limit Fault	Yes/No		SATLA CLR	No
	SAT Freeze Protection	Enable/Disable		SATFZPRO	Enable
	Adaptive Temp Comp Start	Enable/Disable		TCS_CFG	Enable
	User TCS Start Bias Time	0 to 180	min	TCSUBIAS	0
	<b>DMD_CFG</b>	Low Cool Demand On	-1 to 2	°F	DMDLCON
Medium Cool Demand On		0.5 to 20	°F	DMDMCON	1
High Cool Demand On		0.5 to 20	°F	DMDHCON	1.5
Low Cool Demand Off		-1 to 2	°F	DMDLCOFF	-0.5
Cool Demand Level Up		-2 to 2	°F	CDMD_LUP	-0.2
Low Heat Demand On		-1 to 2	°F	DMDLHON	0.5
High Heat Demand On		0.5 to 20	°F	DMDHHON	2
Low Heat Demand Off		-1 to 2	°F	DMDLHOFF	-0.5
Heat Demand Level Up		-2 to 2	°F	HDMD_LUP	-0.2
Space Demand Time Guard1		60 to 600	sec	TDMD_TG1	120
Space Demand Time Guard2		0 to 600	sec	TDMD_TG2	240
Space Demand Time Guard3		5 to 120	min	TDMD_TG3	10
COOL DMD Offset level 1		0 to 99	°F	CLDOLEV1	1
COOL DMD Offset level 2		0 to 99	°F	CLDOLEV2	3
COOL DMD Offset level 3		0 to 99	°F	CLDOLEV3	5
Heat DMD Offset level 1		0 to 99	°F	HTDOLEV1	1
Heat DMD Offset level 2		0 to 99	°F	HTDOLEV2	3
Heat DMD Offset level 3		0 to 99	°F	HTDOLEV3	5

**APPENDIX D — SYSTEMVU™ CONTROLLER CCN TABLES**

**SERVICE CONFIG TABLES (CONT)**

TABLE	DISPLAY NAME	VALUES	UNITS	POINT NAME	DEFAULT	
IN_D_CFG	0 = None					
	1 = MBB DI12					
	2 = MBB DI13					
	3 = MBB DI14					
	4 = MBB DI02					
	5 = MBB DI03					
	6 = MBB Y3					
	COFS Assigned Channel	0 to 6			COFSCHAN	0: No FIOP 4: FIOP
	Remote Occupancy Channel	0 to 6			RMOCCCHAN	0 = NONE
	Remote Shutdown Channel	0 to 6			ROFFCHAN	0 = NONE
	Filter Status Sw Channel	0 to 6			FILTCHAN	0: No FIOP 1: FIOP
	Enthalpy Sw Channel	0 to 6			ENTHCHAN	0 = NONE
	General Status Channel	0 to 6			GEN_CHAN	0 = NONE
	Humidistat Status Chan.	0 to 6			HUMDCCHAN	0 = NONE
	IAQ override sw channel	0 to 6			IAQOCHAN	0 = NONE
	Fan Status Channel	0 to 6			FNSTCHAN	0 = NONE
	Phase Monitor Channel	0 to 6			PMR_CHAN	0: no FIOP 3: FIOP
	Smoke Evacuation Sw Chan	0 to 6			EVACCHAN	0
	Smoke Pressure Sw Chan	0 to 6			PRESCHAN	0
	Smoke Purge Sw Channel	0 to 6			PURGCHAN	0
	Fire Switch Channel	0 to 6			FIRECHAN	0
	0 = Normally Open					
	1 = Normally Closed					
	COFS Switch Type	0 to 1			COFS_CFG	0 = NORM CLSD
	Remote Occupancy Sw Type	0 to 1			RMOCC_CFG	0 = NORM OPEN
	Remote Shutdown SW Type	0 to 1			ROFF_CFG	0 = NORM OPEN
	Filter Status Swith Type	0 to 1			FILT_CFG	0 = NORM OPEN
	Enthalpy Switch Type	0 to 1			ENTH_CFG	0 = NORM OPEN
	General Status Sw Type	0 to 1			GENS_CFG	0 = NORM OPEN
	Humidistat Switch Type	0 to 1			HUMDC_CFG	0 = NORM OPEN
	IAQ Override Switch Type	0 to 1			IAQOSCFG	0 = NORM OPEN
	Fan Status SW Type	0 to 1			FANSTCFG	0 = NORM OPEN
	Phase Monitor SW Type	0 to 1			PMR_CFG	0 = NORM CLSD
	Smoke Evacuation Sw Type	0 to 1			EVAC_CFG	0
	Smoke Pressure Sw Type	0 to 1			PRES_CFG	0
	Smoke Purge Switch Type	0 to 1			PURG_CFG	0
	Fire Shutdown Sw Type	0 to 1			FIRE_CFG	0
	General Status shutdown?	Yes/No			GENFATAL	Yes
	0 = Normal					
	1 = Emergency					
	Remote Shutdown ALM Type	0 to 1			ROFFTYPE	0 = NORMAL
	IN_A_CFG	0 = None				
1 = MBB AI06						
2 = MBB AI07						
3 = MBB AI08						
IAQ Assigned Channel		0 to 3			IAQ_CHAN	0: No FIOP 2: FIOP
OAQ Assigned Channel		0 to 3			OAQ_CHAN	0 = NONE
OARH Assigned Channel		0 to 3			OARHCHAN	0: no FIOP 3: FIOP
RARH Assigned Channel		0 to 3			RARHCHAN	0 = NONE
SPRH Assigned Channel		0 to 3			SPRHCHAN	0 = NONE
OACFM Assigned Channel		0 to 3			OACFMCHAN	0 = NONE

**APPENDIX D — SYSTEMVU™ CONTROLLER CCN TABLES**

**SERVICE CONFIG TABLES**

TABLE	DISPLAY NAME	VALUES	UNITS	POINT NAME	DEFAULT
<b>IN_A_CFG (cont)</b>	SPRH Sensor Value at 4mA	0 to 100	%	SPRH_4MA	0
	SPRH Sensor Value @ 20mA	0 to 100	%	SPRH20MA	100
	IAQ Sensor Value at 4mA	0 to 5000	PPM	IAQ_4MA	0
	IAQ Sensor Value at 20mA	0 to 5000	PPM	IAQ_20MA	2000
	OAQ Sensor Value at 4mA	0 to 5000	PPM	OAQ_4MA	0
	OAQ Sensor Value at 20mA	0 to 5000	PPM	OAQ_20MA	2000
	OARH Sensor Value at 4mA	0 to 100	%	OARH_4MA	0
	OARH Sensor Val. at 20mA	0 to 100	%	OARH20MA	100
	RARH Sensor Value at 4mA	0 to 100	%	RARH_4MA	0
	RARH Sensor Value @ 20mA	0 to 100	%	RARH20MA	100
	OACFM value at 4MA	0 to 2000	CFM	OACFM_4MA	0
	OACFM Value at 20mA	2000 to 5000	CFM	OACFM20MA	2000
<b>IDF_CFG</b>	Fan On When Occupied	Yes/No		FANON_OC	Yes
	IDF Maximum Fan Speed	0 to 100	%	SPEEDMAX	100
	IDF Vent Speed-RPM	0 to 3000	RPM	RPM_VENT	same as IDF LOW COOL SPD (see Page 64)
	IDF Heat Speed-RPM	0 to 3000	RPM	RPM_HEAT	same as IDF HIGH COOL SPD (See page 64)
	IDF Free Cool Speed-RPM	0 to 3000	RPM	RPM_FCL	same as IDF LOW COOL SPD (see Page 64)
	IDF Low Cool Speed-RPM	0 to 3000	RPM	RPM_LC	1106: Size 04 Standard Static Fan 1281: Size 04 Medium Static Fan 1457: Size 04 High Static Fan 1112: Size 05 Standard Static Fan 1269: Size 05 Medium Static Fan 1439: Size 05 High Static Fan 230v 1ph 1556: Size 05 High Static Fan 230v 3ph, 460v, 575v 1258: Size 06 Standard Static Fan 1398: Size 06 Medium Static Fan 1556: Size 06 High Static Fan 230v 1ph 1659: Size 06 High Static Fan 230v 3ph, 460v, 575v 1184: Size 07 Standard Static Fan 1302: Size 07 Medium Static Fan 1460: Size 07 High Static Fan 1106: Size 04 Standard Static Fan 1281: Size 04 Medium Static Fan 1457: Size 04 High Static Fan 1112: Size 05 Standard Static Fan 1269: Size 05 Medium Static Fan 1439: Size 05 High Static Fan 230v 1ph 1556: Size 05 High Static Fan 230v 3ph, 460v, 575v 1258: Size 06 Standard Static Fan 1398: Size 06 Medium Static Fan 1556: Size 06 High Static Fan 230v 1ph 1659: Size 06 High Static Fan 230v 3ph, 460v, 575v 1184: Size 07 Standard Static Fan 1302: Size 07 Medium Static Fan 1460: Size 07 High Static Fan

**APPENDIX D — SYSTEMVU™ CONTROLLER CCN TABLES**

**SERVICE CONFIG TABLES (CONT)**

TABLE	DISPLAY NAME	VALUES	UNITS	POINT NAME	DEFAULT
<i>IDF_CFG (cont)</i>	IDF High Cool Speed-RPM	0 to 3000	RPM	RPM_HCL	1474: Size 04 Standard Static Fan 1708: Size 04 Medium Static Fan 1942: Size 04 High Static Fan 1482: Size 05 Standard Static Fan 1693: Size 05 Medium Static Fan 1919: Size 05 High Static Fan 230v 1ph 2075: Size 05 High Static Fan 230v 3ph, 460v, 575v 1677: Size 06 Standard Static Fan 1864: Size 06 Medium Static Fan 2075: Size 06 High Static Fan 230v 1ph 2212: Size 06 High Static Fan 230v 3ph, 460v, 575v 1794: Size 07 Standard Static Fan 1973: Size 07 Medium Static Fan 2212: Size 07 High Static Fan
	FBDH Min Fan Speed	0 to 3000	RPM	FDRPMMIN	same as IDF LOW COOL SPD (see Page 64)
	FBDH Max Fan Speed	0 to 3000	RPM	FDRPMMAX	same as same as IDF HIGH COOL SPD (See page 64)
	Shut down on IDF Failure	Yes/No		FATALFAN	Yes
	IDF Curve High End RPM	0 to 3000	RPM	IFMHIRPM	1890: Size 04 Standard Static Fan 2190: Size 04 Medium Static Fan 2490: Size 04 High Static Fan 1900: Size 05 Standard Static Fan 2170: Size 05 Medium Static Fan 2460: Size 05 High Static Fan 230v 1ph 2660: Size 05 High Static Fan 230v 3ph, 460v, 575v 2150: Size 06 Standard Static Fan 2390: Size 06 Medium Static Fan 2660: Size 06 High Static Fan 230v 1ph 2836: Size 06 High Static Fan 230v 3ph, 460v, 575v 2300: Size 07 Standard Static Fan 2530: Size 07 Medium Static Fan 2836: Size 07 High Static Fan
	IDF Curve Low End RPM	0 to 3000	RPM	IFMLORPM	189: Size 04 Standard Static Fan 219: Size 04 Medium Static Fan 249: Size 04 High Static Fan 190: Size 05 Standard Static Fan 217: Size 05 Medium Static Fan 246: Size 05 High Static Fan 230v 1ph 266: Size 05 High Static Fan 230v 3ph, 460v, 575v 215: Size 06 Standard Static Fan 239: Size 06 Medium Static Fan 266: Size 06 High Static Fan 230v 1ph 284: Size 06 High Static Fan 230v 3ph, 460v, 575v 230: Size 07 Standard Static Fan 253: Size 07 Medium Static Fan 284: Size 07 High Static Fan
	IDF Min Start RPM	xxxx	RPM	IDFSTSPD	300
	IDF Start Speed Time	xxx	sec	IDFSSTIM	30
	IDF Curve High End PWM	0 to 100	%	IFMHIPWM	97
	IDF Curve Low End PWM	0 to 100	%	IFMLOPWM	10



**APPENDIX D — SYSTEMVU™ CONTROLLER CCN TABLES**

**SERVICE CONFIG TABLES (CONT)**

TABLE	DISPLAY NAME	VALUES	UNITS	POINT NAME	DEFAULT
COOL_CFG	Compressor Min On Time	180 to 600	sec	C_MINON	300
	Compressor Min Off Time	120 to 600	sec	C_MINOFF	180
	Runtime to Reset Strikes	120 to 999	sec	MIN_ON_S	300
	Cool Stage Increase Time	120 to 999	sec	CSTAGINC	450
	Cooling SAT Trend Level	-1 to 1		SAT_TLC	-0.2
	Cool Min SAT Upper Level	35.0 to 65.0	°F	SATMIN_H	56
	Cool Min SAT Lower Level	35.0 to 65.0	°F	SATMIN_L	46
	Cooling Fan-Off Delay	0 to 600	sec	COOL_FOD	60
	ODF High Speed Time	0 to 300	sec	MINODFTM	120
	ODF Relay Enabled	Yes/No		OFR_EN	No: 50FCQ Yes: 50GCQ
	Circuit A Lockout Temp	-20 to 75	°F	OATLCMPA	40: no FIOP 0: Low Ambient FIOP
	Low Cool lockout Temp	-20 to 60	°F	LCLOCKSP	10
	Low Refrig Charge Level	0 to 150	PSI	LOCHARGE	50
	Low Charge Disable Temp	-40 to 50	°F	LOCH_LOT	10
	CirA High Pressure Limit	400 to 700	PSI	HIPLIM_A	670
	Low Discharge Level	0 to 20	°F	SDTLEV	0
	Low Discharge Diagnostic	Enable/Disable		DISLDPAL	Disable
	Minimum Pressure Ratio	0 to 5		MINPSI_R	1.35
	Suction OK Temperature	10 to 50	°F	SSTOK	18
	Low Suction Level 1 Temp	10 to 50	°F	SSTLEV1	20
	Low Suction Level 2 Temp	5 to 50	°F	SSTLEV2	15
	Low Suction Level 3 Temp	0 to 50	°F	SSTLEV3	10
	Delay On Low SST Check	0 to 300	sec	SSTCKDLY	0: no FIOP
	Comp Level 2 Diag Delay	1 to 99	sec	CDDTLEV2	15
	Diag Comp Unexpected Off	Enable/Disable		CD_UEOFF	Enable
	Circuit Stuck On Diag.	Enable/Disable		DCKTOFF	Enable
	Min discharge change	0 to 99	PSI	MDP_DISA	8
	Min Suction change	0 to 99	PSI	MDP_SUCA	10
	CirA P.Ratio off change	-1 to 1		OFFPR_A	-0.3
	Compressor Framework	0 to 2	0 to 2	SYSVTYPE	1: All except below 2: 50FCQ 04-06
	0 = 2 Compressors				
	1 = Compressor + Loader				
	2 = Compressor Only				
	Comp A1 Shutdown First	Yes/No		SDWN_A1	No
Comp Loader Shutdown 1st	Yes/No		SDWN_ALD	Yes: All except below No: 50FCQ 04-06	
Fan Based Dehum Type	0=NONE, 1=Comfort, 2=Max		FBD_TYPE	0 = NONE	
FBDH Low Set Point	-20 to 0	ΔF	FBDLO_SP	-2.5	
FBDH Max Mode SST SP	20 to 60	°F	FBDSSTSP	38	
FBDH Min SST Threshold	10 to 60	°F	FBDH_SST	32	
FBDH Comfort SAT SP	35 to 80	°F	FBDH_SAT	46	
FBD Comfort SAT Delta	0 to 30	°F	FBDSATDT	11	

**APPENDIX D — SYSTEMVU™ CONTROLLER CCN TABLES**

**SERVICE CONFIG TABLES (CONT)**

TABLE	DISPLAY NAME	VALUES	UNITS	POINT NAME	DEFAULT
HEATCFG	Number Of Heating Stages	0 to 2		NUMHSTGS	1
	Heat Minimum On Time	60 to 600	sec	H_MINON	120
	Heat Minimum Off Time	60 to 600	sec	H_MINOFF	120
	Heat Stage Increase Time	120 to 999	sec	HSTAGINC	450
	Heating SAT Trend Level	-1 to 1		SAT_TLH	0.2
	Heat Max SAT Lower Level	85 to 200	°F	SATMAX_L	140
	Heat Max SAT Upper Level	85 to 200	°F	SATMAX_H	170
	Heating Fan-Off Delay	10 to 600	sec	HEAT_FOD	60
	Heating Lockout Temp	40 to 125	°F	OATLHEAT	75
	SAT heat mode sensing	Enable/Disable		SAT_HEAT	Enable
	Pre-Heat HX without IDF?	Enable/Disable		PREHT_HX	Disable
	Supply Air Temper Enable	Yes/No		SATEMPEN	No
	SA tempering Set point	35 to 80	°F	SATEMPSP	55
	Max OAT for SA tempering	40 to 80	°F	OATSTEMP	65
	LiquidLine Valve On Time	0 to 300	sec	LLSV_CT	60
	Min Time BTWN Defrosts	30 to 120	min	MINDFINT	60
	Defrost Max Duration	5 to 25	min	MAXDFTMR	10
	Startup Defrost Delay	0 to 120	min	DFHLD_T	5
	Comp UEOFF Diag Delay	0 to 300	sec	ACAOFF_T	30
	Max OAT for 3 Heat Stags	0 to 90	°F	HT2LCTMP	20
	Mech Heat Lockout Temp	-30 to 40	°F	OATLMECH	-8
ECON_CFG	Ventilation Method	0 to 4		VENTTYPE	0: No FIOP 1: Economizer FIOP 2: Two Position Damper FIOP
	0 = None				
	1 = Economizer				
	2 = 2-Position Damper				
	3 = ERV				
	4 = Economizing ERV				
	Econ Max Damper Position	0 to 100	%	DAMPMAX	100
	Economizer Travel Time	5 to 300	sec	ECONOTRV	150
	IDF Maximum Fan Speed	0 to 100	%	SPEEDMAX	100
	Econ Min at Max Fanspeed	0 to 100	%	MINP_MAX	30
	Min Pos - User Speed 1	0 to 100	%	MP_USPD1	0
	Min Pos - User Pos 1	0 to 100	%	MP_UPOS1	0
	Min Pos - User Speed 2	0 to 100	%	MP_USPD2	0
	Min Pos - User Pos 2	0 to 100	%	MP_UPOS2	0
	Min Pos - User Speed 3	0 to 100	%	MP_USPD3	0
	Min Pos - User Pos 3	0 to 100	%	MP_UPOS3	0
	LowFree Cool SAT Setpnt	40 to 80	°F	LCSASP	65
	High FreeCool SAT Setpnt	40 to 80	°F	HCSASP	55
	Free Cooling Max OAT	0 to 90	°F	MAXFREET	65
	Free Cooling Min Temp	-30 to 70	°F	MINFREET	0
	Diff. Dry Bulb Control	Enable/Disable		DIFFBULB	Disable
	Diff. Dry Bulb Deadband	0 to 20	°F	OATRATDB	3
	Max Enthalpy OA limit	1 to 99	BTU_LB	FREEMAXE	28
	Diff. Enthalpy Control	Enable/Disable		DIFFENTH	Disable
	Enthalpy Cross Deadband	0 to 20	BTU_LB	OAERAEDB	2
	ECONO PID - KP	0.00 to 99.90		ECONO_P	2.5
	ECONO PID - KI	0.00 to 99.90		ECONO_I	0.12
	ECONO PID - KD	0.00 to 99.90		ECONO_D	1
	ECONO PID - RATE	10 to 180	sec	ECONO_DT	15
	When to Unocc Free Cool?	0 to 2		UFC_CFG	1 = PreOcc
0 = Disabled					
1 = Pre-Occupancy					
2 = Unoccupied					

**APPENDIX D — SYSTEMVU™ CONTROLLER CCN TABLES**

**SERVICE CONFIG TABLES (CONT)**

TABLE	DISPLAY NAME	VALUES	UNITS	POINT NAME	DEFAULT	
<b>ECON_CFG (cont)</b>	UFC PreOcc Time	1 to 999	min	UFCTIME	120	
	Unocc Free Cool Low Temp	-30 to 70	°F	OATLUFC	50	
	PE Stage 1 At Max Speed	0 to 100	%	PE1_PMAX	40	
	PE1 Relay Channel	0=NONE, 1=MBB RLY11, 2=MBB RLY06		PE1_CHAN	0: No FIOP 2: FIOP	
	PE Turn Off Dead band	0 to 100	%	PE_OFFDB	5	
	PE2 Relay Channel	0=NONE, 1=MBB RLY11, 2=MBB RLY06		PE2_CHAN	0 = NONE	
	PE Stage 2 At Max Speed	0 to 100	%	PE2_PMAX	75	
	T24 Heat/Cool End Delay	0 to 60	min	T24CHDLY	25	
	T24Econ Min Move for SAT	10 to 20	%	T24ECSTS	10	
	Damper SAT deadband	0 to 20	°F	T24SATDB	12	
	T24 Min Diff in RAT-OAT	5 to 20	°F	T24RATDF	15	
	T24 Test Minimum Pos	0 to 100	%	T24TSTMN	15	
	T24 Test Maximum Pos	0 to 100	%	T24TSTMX	85	
	<b>IAQ_CFG</b>	Analog Input IAQ Control	0 to 3		IAQANCFG	0: No FIOP 1: CO <sub>2</sub> FIOP
		0 = No IAQ				
		1 = DCV				
		2 = IAQ Override				
3 = MINPOS Control						
IAQ Position at Max Fan		0 to 100	%	IAQMINP	10	
AQ Differential Low		0 to 5000		DAQ_LOW	100	
AQ Differential High		0 to 5000		DAQ_HIGH	700	
IAQ Preoccupancy Purge		Yes/No		IAQPURGE	Yes	
IAQ Purge Pos at Max IDF		0 to 100	%	IAQPMAX	40	
Preocc Purge Lockout OAT		0 to 70	°F	IAQP_LA	50	
Preocc Purge Duration		5 to 120	min	IAQPTIME	15	
IAQ Sensor Value at 4mA		0 to 5000	PPM	IAQ_4MA	0	
IAQ Sensor Value at 20mA		0 to 5000	PPM	IAQ_20MA	2000	
OAQ Sensor Value at 4mA		0 to 5000	PPM	OAQ_4MA	0	
OAQ Sensor Value at 20mA		0 to 5000	PPM	OAQ_20MA	2000	
IAQ override sw channel		0=None, 1=MBB DI12, 2=MBB DI13, 3=MBB DI14, 4=MBB DI02, 5=MBB DI03, 6=MBB Y3		IAQOCHAN	0 = NONE	
IAQ Override Switch Type	0=NORM OPEN, 1=NORM CLSD		IAQOSCFG	0 = NORM OPEN		
<b>ALM_CFG</b>	ALM Relay Assigned Chan	0 to 2		ALM_CHAN	1 = MBB RLY11	
	0 = None					
	1 = MBB RLY11					
	2 = MBB RLY06					
	Thermostat Alerts	Yes/No		TSTAT_AL	Yes	
	Hardware Failures Alerts	Yes/No		HW_AL	Yes	
	SAT/RAT Sensor Alerts	Yes/No		SATRATAL	Yes	
	OAT Thermistor Alerts	Yes/No		OATRL_AL	Yes	
	Space Sensors Alerts	Yes/No		SPACE_AL	Yes	
	Transducer Sensor Alerts	Yes/No		TRANS_AL	Yes	
	RH sensor failure Alert	Yes/No		RHS_AL	Yes	
	Air Quality CO2 Alerts	Yes/No		CO2S_AL	Yes	
	OACFM Alarm Relay	Yes/No		OACFM_AL	No	
	Economizer Alerts	Yes/No		ECON_AL	Yes	

**APPENDIX D — SYSTEMVU™ CONTROLLER CCN TABLES**

**SERVICE CONFIG TABLES (CONT)**

TABLE	DISPLAY NAME	VALUES	UNITS	POINT NAME	DEFAULT
<b>ALM_CFG (cont)</b>	Dirty Filter Alerts	Yes/No		FILT_AL	Yes
	General Status Alerts	Yes/No		GENS_AL	Yes
	Refrig Circuit Alerts	Yes/No		CKT_AL	Yes
	Compressor Alerts	Yes/No		COMP_AL	Yes
	Heating Failure Alerts	Yes/No		HEAT_AL	Yes
	Indoor Fan Alerts	Yes/No		FAN_AL	Yes
	Relay On Active Faults	Yes/No		FAULT_AL	Yes
<b>ZSENSCFG</b>	Zone Sensor 1 Address	0 to 255		ZSADDR1	255
	Zone Sensor 2 Address	0 to 255		ZSADDR2	255
	Zone sensor 3 address	0 to 255		ZSADDR3	255
	Zone sensor 4 address	0 to 255		ZSADDR4	255
	Zone sensor 5 address	0 to 255		ZSADDR5	255
	ZS Force Unoccup enable	Yes/No		ZSFUNEN	No
	ZS Force unocc wt delay	Yes/No		ZSFUNWT	No
	Zone sensor poll rate	1 to 100	sec	ZSPOLLRT	5
	ZS TLO Cont Enable	Yes/No		ZSTLOEN	No
	ZS TLO set during occ	Yes/No		ZSTLSOC	No
	Zone sensor UI Mode	1 = Dual Offsets		ZSUIM	1 = Dual Offsets
Zone sensor unit	0 = degrees F		ZSUNIT	0 = degrees F	
<b>TOUCHCFG</b>	System Touch Device Inst	0 to 4194303		DEVST	160099
	System Touch Poll Rate	10 to 60		POLLST	10
	System Touch AI for SPT	0 to 9999		AISTSPT	1
	System Touch AI for SPRH	0 to 9999		AISTSPRH	4
<b>TRIM</b>	OAT Sensor Trim Offset	-10 to 10	°F	OAT_TRIM	0
	RAT Sensor Trim Offset	-30 to 30	°F	RAT_TRIM	0
	FST Sensor Trim Offset	-10 to 10	°F	FST_TRIM	0
	SPT Sensor Trim Offset	-30 to 30	°F	SPT_TRIM	0
	SPTO Sensor Offset Trim	-1 to 1	°F	SPTOTRIM	0
	SPRH Sensor Trim Offset	-15 to 15	%	SPRHTRIM	0
	IAQ sensor trim offset	-200 to 200	PPM	IAQ_TRIM	0
	OAQ Sensor Trim Offset	-200 to 200	PPM	OAQ_TRIM	0
	OARH Sensor Trim Offset	-15 to 15	%	OARHTRIM	0
	RARH Sensor Trim Offset	-15 to 15	%	RARHTRIM	0
	Cir.A SSP Sensor Trim	-50 to 50	PSI	SSPATRIM	0
	Cir.A SDP Sensor Trim	-50 to 50	PSI	SDPATRIM	0
	Econ Fdback Trim Offset	-15 to 15	%	EC1DTRIM	0
	OACFM sensor trim offset	-200 to 200	CFM	OACFMTRIM	0
	Damper Low Calib. Error	xx	%	ECOMINCA	
	Damper High Calib. Error	xx	%	ECOMAXCA	
	<b>DISPLAY</b>	Metric Display	Yes/No		DISPUNIT
Display Language Select		0=English, 1=Spanish		LANGUAGE	0 = English
LCD Contrast Adjustment		1 to 10		LCD_CONT	5
User Password Protection		Enable/Disable		PASS_EBL	Enable
User Password		0 to 9999		PASSWORD	1111

## APPENDIX D — SYSTEMVU™ CONTROLLER CCN TABLES

### CONFIGURATION TABLES

TABLE	DISPLAY NAME	VALUES	UNITS	POINT NAME	WRITE STATUS/ DEFAULT	
<b>SCHEDOVR</b>	CCN Schedule Number	0 = Always Occupied, 1-64 = Local Schedule, 65-99 = Global Schedule		SCHEDNUM	0	
	Accept Global Holidays?	Yes/No		HOLIDAYT	No	
	Global Schedule Broadcst	Yes/No		CCN_GSBC	No	
	Timed Override Duration	0 to 4	hours	OTL_CFG	4	
	Timed Override Remaining	0 to 240	min	OVR_EXT	Forcible	
	Remote Occupancy Channel	0=None, 1=MBB DI12, 2=MBB DI13, 3=MBB DI14, 4=MBB DI02, 5=MBB Y3		RMOCCHAN	0=None	
	Allow Global Overrides	Yes/No		GLBLOVER	Yes	
	Allow SPT Ovrld Cancel	Yes/No		CLROVCFG	No	
	<b>BAS_CFG</b>	BAS Protocol Select	0=NONE, 1=CCN, 2=BACNET		BMS_CFG	2=BACNET
Network Input Timeout		0 to 600	min	NETINTO	30	
CCN Bus Number		0 to 239		CCNBUS	0	
CCN Element Number		1 to 239		CCNADD	1	
CCN Baud Rate		0=9600, 1=19200, 2=38400		BAUDENUM	2	
BACnet ID Number		0 to 4194302		BAC_ID	1610101	
BACnet Device Macaddress		1 to 127		BAC_MAC	1	
BACnet BMS baud rate		0=9600, 1=19200, 2=38400, 3=57600, 4=76800, 5=115200		BAC_BAUD	4=76800	
BACnet ID Auto ID		Yes/No		BAC_AUID	Yes	
ALC Auto Id Scheme		Yes/No		AUID	Yes	
<b>BACNET</b>		BACnet Device Macaddress	1 to 127		BAC_MAC	1
		BACnet BMS baud rate	0=9600, 1=19200, 2=38400, 3=57600, 4=76800, 5=115200		BAC_BAUD	4=76800
	BACnet ID Auto ID	Yes/No		BAC_AUID	Yes	
	ALC Auto Id Scheme	Yes/No		AUID	Yes	
	BACnet device for IAQ	0 to 4194303		DEVIAQ	1610100	
	Object instance for IAQ	0 to 9999		OBJIAQ	1009	
	Change of value for IAQ	0 to 60		COVIAQ	0	
	BACnet device for OAQ	0 to 4194303		DEVOAQ	1610100	
	Object instance for OAQ	0 to 9999		OBJOAQ	285	
	Change of value for OAQ	0 to 60		COVOAQ	0	
	BACnet device for OARH	0 to 4194303		DEVOARH	1610100	
	Object instance for OARH	0 to 9999		OBJOARH	1022	
	Change of value for OARH	0 to 60		COVOARH	0	
	BACnet device for OAT	0 to 4194303		DEVOAT	1610100	
	Object instance for OAT	0 to 9999		OBJOAT	1003	
	Change of value for OAT	0 to 60		COVOAT	0	
	BACnet device for RARH	0 to 4194303		DEVRARH	1610100	
	Object instance for RARH	0 to 9999		OBJRARH	30	
	Change of value for RARH	0 to 60		COVRARH	0	
	BACnet device for RAT	0 to 4194303		DEVSTAT	1610100	
	BACnet ID Number	0 to 4194302		BAC_ID	1610101	

**APPENDIX D — SYSTEMVU™ CONTROLLER CCN TABLES**

**CONFIGURATION TABLES (CONT)**

TABLE	DISPLAY NAME	VALUES	UNITS	POINT NAME	WRITE STATUS/ DEFAULT
<b>BACNET (cont)</b>	Object instance for RAT	0 to 9999		OBJRAT	1010
	Change of value for RAT	0 to 60		COVRAT	0
	BACnet device for SPT	0 to 4194303		DEVSP	1610100
	Object instance for SPT	0 to 9999		OBJSPT	2007
	Change of value for SPT	0 to 60		COVSPT	0
<b>BRODEFS</b>	CCN Broadcast Ack'er	Yes/No		CCNBCACK	No
	Global Schedule Broadcst	Yes/No		CCN_GSBC	No
	CCN Time Broadcast	Yes/No		CCNBC	No
	Broadcast OAT On Network	Yes/No		OATBC	No
	Broadcast OARH On Netwrk	Yes/No		OARHBC	No
	Broadcast OAQ On Network	Yes/No		OAQBC	No
	Broadcast IAQ On Network	Yes/No		IAQBC	No
	DST allowed?	Enable/Disable		DST_CFG	Enable
	DST Start Month	1=JANUARY, 2=FEBRUARY, 3=MARCH, 4=APRIL, 5=MAY, 6=JUNE, 7=JULY, 8=AUGUST, 9=SEPTEMBER, 10=OCTOBER, 11=NOVEMBER, 12=DECEMBER		STARTM	3
	DST Start Week	1 to 5		STARTW	2
	DST Start Day	1=MONDAY, 2=TUESDAY, 3=WEDNESDAY, 4=THURSDAY, 5=FRIDAY, 6=SATURDAY, 7=SUNDAY		STARTD	7
	DST Minutes to Add	0 to 90	min	MINADD	60
	DST Stop Month	1=JANUARY, 2=FEBRUARY, 3=MARCH, 4=APRIL, 5=MAY, 6=JUNE, 7=JULY, 8=AUGUST, 9=SEPTEMBER, 10=OCTOBER, 11=NOVEMBER, 12=DECEMBER		STOPM	11
	DST Stop Week	1 to 5		STOPW	1
	DST Stop Day	1=MONDAY, 2=TUESDAY, 3=WEDNESDAY, 4=THURSDAY, 5=FRIDAY, 6=SATURDAY, 7=SUNDAY		STOPD	7
DST Minutes to Subtract	0 to 90	min	MINSUB	60	
Time in day to start DST	0 to 600	min	DST_TOD	120	
<b>ALARMDEF</b>	Alarm Routing Control	00000000 to 11111111		ALRM_CNT	11000000
	Equipment Priority	0 to 7		EQP_TYPE	5
	Comm Failure Retry Time	1 to 240	min	RETRY_TM	10
	Re-Alarm Time	1 to 255	min	RE-ALARM	180
	Alarm System Name	up to 8 alphanum		ALRM_NAM	FCQ_GCQ

**APPENDIX D — SYSTEMVU™ CONTROLLER CCN TABLES**

**CONFIGURATION TABLES (CONT)**

TABLE	DISPLAY NAME	VALUES	UNITS	POINT NAME	WRITE STATUS/ DEFAULT
<b>HOLIDAY</b>					
<b>HOLDYxxS</b>					
<b>MON</b>	Holiday Start Month	1 to 12 = January to December		HD01STMN - HD30STMN	0
<b>DAY</b>	Holiday Start Day	1 to 31		HD01STDY - HD30STDY	0
<b>LEN</b>	Holiday Duration (days)	1 to 99		HD01LEN - HD30LEN	0
(repeat up to xx=30 Holidays)					
<b>OCCDEFCS</b>					
<b>OCCPC01S</b>	Timed Override Remaining	0 to 240	min	OVR_EXT	Forcible
	Period x DOW (MTWTFSSH)	00000000 to 11111111		DOWx	00000000
	Occupied from	hh:mm		OCCTODx	00:00
	Occupied to	hh:mm		UNOCTODx	00:00
(repeat up to x=8 periods)					

**SETPOINT TABLE**

TABLE NAME	DISPLAY NAME	VALUES	UNITS	POINT NAME	DEFAULT
<b>SET_PNT</b>	Occupied Cool Setpoint	55 to 80	°F	OCSP	78
	Occupied Heat Setpoint	55 to 80	°F	OHSP	68
	Unoccupied Cool Setpoint	65 to 95	°F	UCSP	85
	Unoccupied Heat Setpoint	40 to 80	°F	UHSP	60
	Heat-Cool Setpoint Gap	2 to 10	^F	HCSP_GAP	5
	SPT Offset Range (+/-)	0 to 5	°F	SPTO_RNG	5
	Occupied SPRH Setpoint	0 to 100	%	SPRH_OSP	55
	Unoccupied SPRH Setpoint	0 to 100	%	SPRH_USP	55

**CONTROL ID TABLE**

TABLE NAME	DISPLAY NAME	VALUES	UNITS	POINT NAME	DEFAULT
<b>CTRLID</b>	Device Name:	FCQ_GCQ			
	Description:	text string			
	Location:	text string			
	Software Part Number:	CESR131690-01-xx			
	Model Number:	2 to 10			
	Serial Number:	0 to 5			
	Reference Number:	0 to 5			

## APPENDIX E — BACKNET\* POINTS LIST

### ANALOG VALUE (AV) POINTS

POINT DESCRIPTION	POINT ACCESS	UNITS	BACnet OBJECT NAME	BACnet ID	VALUE RANGE	CCN POINT EQUIVALENT
2-Pos Damper/ERV Channel	R/W	R/W	erv2chan	AV:8049	0 TO 2	EV2PCHAN
2Position/ERV ResetCount	READ ONLY		rs_erv2p	AV:8046	0 TO 65535	RS_ERV2P
2Position/ERV Run Hours	READ ONLY	hrs	hr_erv2p	AV:8055	0 TO 999999	HR_ERV2P
2Position/ERV Starts	READ ONLY		st_erv2p	AV:8047	0 TO 999999	ST_ERV2P
A1 Loader Resets Count	READ ONLY		rs_aldr	AV:7012	0 TO 65535	RS_ALDR
Actual Cool Stage Active	READ ONLY		actcstgs	AV:194	0 TO 3	ACTCSTGS
Actual Heat Stage Active	READ ONLY		acthstgs	AV:46	0 TO 2	ACTHSTGS
Alarm display info	READ ONLY		alarm_info	AV:14	0 TO 2	ALARM
Alarm Relay Resets Count	READ ONLY		rs_alm	AV:99	0 TO 65535	RS_ALM
Alarm Relay Run Hours	READ ONLY	hrs	hour_alarm	AV:49	0 TO 999999	HR_ALM
Alarm Relay Starts	READ ONLY		st_alm	AV:136	0 TO 999999	ST_ALM
Alarm Reset Counts	READ ONLY		st_alrst	AV:137	0 TO 999999	ST_ALRST
Alarm Reset Resets Count	READ ONLY		rs_alrst	AV:100	0 TO 65535	RS_ALRST
AQ Diff Low-IAQ OVERRIDE	R/W	PPM	aqd_low	AV:443	0 TO 5000	AQD_LOW
AQ Differential High	R/W		daq_high	AV:212	0 TO 5000	DAQ_HIGH
AQ Differential Low	R/W	R	daq_low	AV:213	0 TO 5000	DAQ_LOW
AQ DiffHigh-IAQ OVERRIDE	R/W	PPM	aqd_high	AV:442	0 TO 5000	AQD_HIGH
Average Occup. Cool Stp.	R/W	°F	lnk_ocsp	AV:264	55 TO 80	LNK_OCSP
Average Occup. Heat Stp.	R/W	°F	lnk_ohsp	AV:266	55 TO 80	LNK_OHSP
Average Occup. Zone Temp	R/W	°F	lnk_aozt	AV:255	-40 TO 245	LNK_AOZT
Average Unocc. Cool Stp.	R/W	°F	lnk_ucsp	AV:274	65 TO 90	LNK_UCSP
Average Unocc. Heat Stp.	R/W	°F	lnk_uhsp	AV:275	40 TO 80	LNK_UHSP
Average Zone Temperature	R/W	°F	lnk_azt	AV:256	-40 TO 245	LNK_AZT
BACKUP Preparation Time	READ ONLY		bkpreptm	AV:336	0 TO 65535	BKPREPTM
BACnet device for IAQ	R/W		deviaq	AV:8001	0 TO 4194303	DEVIAQ
BACnet device for OAQ	R/W		devoaq	AV:8002	0 TO 4194303	DEVOAQ
BACnet device for OARH	R/W		devoarh	AV:8004	0 TO 4194303	DEVOARH
BACnet device for OAT	R/W		devoat	AV:8003	0 TO 4194303	DEVOAT
BACnet device for RARH	R/W		devrarh	AV:8005	0 TO 4194303	DEVRARH
BACnet device for RAT	R/W		devrat	AV:8006	0 TO 4194303	DEVSTAT
BACnet device for SPRH	R/W		devsprh	AV:8028	0 TO 4194303	DEVSPRH
BACnet device for SPT	R/W		devspt	AV:8007	0 TO 4194303	DEVSTAT
BACnet Device Macaddress	R/W		bac_mac	AV:189	0 TO 127	BAC_MAC
BACnet ID Number	R/W		bac_id	AV:188	0 TO 4194302	BAC_ID
Barometric Pressure	R/W	IN_HG_OF_KPAG	barp	AV:161	10 TO 35	BARP
Block No: in Master Zone	R/W		lnk_mzbk	AV:262	0 TO 255	LNK_MZBK
CCH Max Temperature	R/W	°F	cch_max_t	AV:2	40 TO 90	CCHMAXT
CCH1 Relay Resets Count	READ ONLY		rs_cchr1	AV:294	0 TO 65535	RS_CCHR1
CCH1 Relay Run Hours	READ ONLY	hrs	hour_cchr1	AV:242	0 TO 999999	HR_CCHR1
CCH1 Relay Starts	READ ONLY		st_cchr1	AV:301	0 TO 999999	ST_CCHR1
Change Filter Timer	R/W	hrs	filter_service_hrs	AV:2019	0 TO 9999	FILT LIFE
Change of value for IAQ	R/W		coviaq	AV:8015	0 TO 60	COVIAQ
Change of value for OAQ	R/W		covoaq	AV:8016	0 TO 60	COVOAQ
Change of value for OARH	R/W		covoarh	AV:8018	0 TO 60	COVOARH
Change of value for OAT	R/W		covoat	AV:8017	0 TO 60	COVOAT
Change of value for RARH	R/W		covrarh	AV:8019	0 TO 60	COVRARH
Change of value for RAT	R/W		covrat	AV:8020	0 TO 60	COVRAT
Change of value for SPRH	R/W		covsprh	AV:8030	0 TO 60	COVSPRH
Change of value for SPT	R/W		covspt	AV:8021	0 TO 60	COVSPT
Cir.A Discharge Pressure	R/W	PSI	sdp_a	AV:124	-67.06 TO 699.63	SDP_A
Cir.A Sat.Discharge Temp	READ ONLY	°F	sdt_a	AV:295	-100 TO 500	SDT_A
Cir.A Sat.Suction Temp	READ ONLY	°F	sst_a	AV:339	-100 TO 500	SST_A
Cir.A Suction Pressure	READ ONLY	PSI	ssp_a	AV:131	-47.33 TO 430.16	SSP_A
Circuit A Pressure Ratio	READ ONLY		cira_pr	AV:204	14.5 TO 667.0	CIRA_PR
CMP A1 Loader Run Hours	READ ONLY	hrs	hr_aldr	AV:7010	0 TO 999999	HR_ALDR
CMP A1 Loader Starts	READ ONLY		st_aldr	AV:7011	0 TO 999999	ST_ALDR
cmp Loader Timeguard	READ ONLY	sec	timg_ald	AV:164	0 TO 600	TIMG_ALD
Comp A1 Resets Count	READ ONLY		rs_a1	AV:97	0 TO 65535	RS_A1

\* BACnet is a registered trademark of ASHRAE (American Society of Heating, Refrigerating and Air-Conditioning Engineers).



**APPENDIX E — BACNET POINTS LIST**

**ANALOG VALUE (AV) POINTS (CONT)**

POINT DESCRIPTION	POINT ACCESS	UNITS	BACnet OBJECT NAME	BACnet ID	VALUE RANGE	CCN POINT EQUIVALENT
Comp UEOFF Diag Delay	R/W	sec	acaoff_t	AV:462	0 TO 300	ACAOFF_T
Compressor A1 Run Hours	READ ONLY	hrs	hour_a1	AV:47	0 TO 999999	HR_A1
Compressor A1 Run Hours	READ ONLY	hrs	hr_rlv_a	AV:458	0 TO 999999	HR_RLV_A
Compressor A1 Starts	READ ONLY		st_a1	AV:134	0 TO 999999	ST_A1
Compressor A1 strikes	READ ONLY		a1strike	AV:192	0 TO 3	A1STRIKE
Compressor A1 Timeguard	READ ONLY	sec	timgd_a1	AV:162	0 TO 600	TIMGD_A1
Compressor Min Off Time	R/W	sec	c_minoff	AV:202	120 TO 600	C_MINOFF
Compressor Min On Time	R/W	sec	c_minon	AV:203	180 TO 600	C_MINON
COOL DMD Offset level 1	R/W	°F	cdlm_level1	AV:400	0 TO 40	CLDOLEV1
COOL DMD Offset level 2	R/W	°F	cdlm_level2	AV:401	0 TO 40	CLDOLEV2
COOL DMD Offset level 3	R/W	°F	cdlm_level3	AV:402	0 TO 40	CLDOLEV3
Cool Mode Select T.guard	READ ONLY	sec	cl_sel_timeguard	AV:40	0 TO 65535	COOLMSTG
Cool Setpoint in Effect	READ ONLY	°F	csp_eff	AV:208	55 TO 95	CSP_EFF
Cool Shed 1 demand band	R/W		coolsh1	AV:6014	0 TO 55	COOLSH1
Cool Shed 2 demand band	R/W		coolsh2	AV:6015	0 TO 55	COOLSH2
Cool Shed 3 demand band	R/W		coolsh3	AV:6016	0 TO 55	COOLSH3
Cooling Demand Trend	READ ONLY		cldtrend	AV:205	-99 TO 99	CLDTREND
Cooling Fan-Off Delay	R/W	sec	cool_fod	AV:207	0 TO 600	COOL_FOD
Damper Actual Position	R/W	%	oa_dmpr_pos	AV:2022	0 TO 1	DAMPPOS
Damper SAT deadband	R/W	°F	t24satddb	AV:308	0 TO 20	T24SATDB
Defrost Max Duration	R/W	min	maxdftmr	AV:8042	5 TO 25	MAXDFTMR
Defrost Mode Starts	READ ONLY		st_dfrst	AV:9012	0 TO 999999	ST_DFRST
Defrost Reset Count	READ ONLY		rs_dfrst	AV:9013	0 TO 65535	RS_DFRST
Defrost Run Hours	READ ONLY	hrs	hr_dfrst	AV:9011	0 TO 999999	HR_DFRST
Delay On Low SST Check	R/W	sec	sstckdly	AV:300	0 TO 300	SSTCKDLY
Diff. Dry Bulb Deadband	R/W	°F	oa_ra_diff_temp	AV:78	1.0f TO 99.0f	OATRATDB
Differential Air Quality	READ ONLY	PPM	aq_diff	AV:195	-5000 TO 5000	AQ_DIFF
Econ Damper Resets Count	READ ONLY		rs_damp	AV:102	0 TO 65535	RS_DAMP
Econ Damper Run Hours	READ ONLY	hrs	hour_damp	AV:51	0 TO 999999	HR_DAMP
Econ Max Damper Position	R/W	%	dampmax	AV:185	0 TO 1	DAMPMAX
Econ Min at Max Fanspeed	R/W	%	minp_max	AV:318	0 TO 1	MINP_MAX
Econo Actual Position	READ ONLY	%	dampact	AV:211	0 TO 1	DAMPACT
Econo Commanded Position	R/W	%	dmpr_cmd	AV:4	0 TO 1	DAMPCMD
Economizer Damper Starts	READ ONLY		st_damp	AV:139	0 TO 999999	ST_DAMP
Economizer Position Test	R/W	%	s_damper	AV:118	0 TO 1	S_DAMPER
Economizer Travel Time	R/W	sec	econotrsv	AV:226	5 TO 300	ECONOTRV
Effective Deadband	R/W		effdb	AV:6007	0 TO 55	EFFDB
Effective Demand Temp	READ ONLY	°F	temp_eff	AV:163	-40 TO 245	TEMP_EFF
Effective Zone Setpoint	R/W	°F	effsp	AV:6006	55 TO 90	EFFSP
Enthalpy Cross Deadband	R/W	BTU_LB	oa_ra_diff_enth	AV:77	0 TO 20	OAERAEDB
Equipment Touch RH	R/W	%	EquipmentTouchRH	AV:1904	0 TO 1	ETSPRH
Equipment Touch SPT	R/W	°F	EquipmentTouchSPT	AV:1902	-40 TO 240	ETSPT
Fan Supply Air Temp	READ ONLY	°F	idf_sa_temp	AV:10	-40 TO 245	FST
FBDH Low Set Point	R/W	°F delta	fdlosp	AV:438	-20 TO 0	FBDLO_SP
FBDH Max Fan Speed	R/W	RPM	fdrpmmx	AV:8057	0 TO 5000	FDRPMMAX
FBDH Min Fan Speed	R/W	RPM	fdrpmmn	AV:8056	0 TO 5000	FDRPMMIN
FBDH SAT Min value	R/W	°F	fbdh_sat	AV:436	35 TO 80	FBDH_SAT
FBDH SAT Set Point	READ ONLY	°F	fbdsatsp	AV:441	0 TO 240	FBDSATSP
FBDH SST Min value	R/W	°F	fbdh_sst	AV:437	10 TO 60	FBDH_SST
Filter hour remaining	READ ONLY	hrs	filter_rmtm	AV:2015	0 TO 9999	FILTLEFT
Free Cooling Max OAT	R/W	°F	max_free_cl_temp	AV:67	0 TO 90	MAXFREET
Free Cooling Min Temp	R/W	°F	min_free_cl_temp	AV:71	-30 TO 70	MINFREET
Free Cooling Reset Count	READ ONLY		rs_freec	AV:104	0 TO 65535	RS_FREEC
Free Cooling Run Hours	READ ONLY	hrs	hour_free_cl	AV:53	0 TO 999999	HR_FREEC
Free Cooling Starts	READ ONLY		st_freec	AV:141	0 TO 999999	ST_FREEC
Full Load Resets Count	READ ONLY		rs_fload	AV:103	0 TO 65535	RS_FLOAD
Heat Demand Level Up	R/W	°F	hadmd_lup	AV:239	-2 TO 2	HDMD_LUP
Heat DMD Offset level 1	R/W	°F	hdlm_level1	AV:403	0 TO 40	HTDOLEV1
Heat DMD Offset level 2	R/W	°F	hdlm_level2	AV:404	0 TO 40	HTDOLEV2
Heat DMD Offset level 3	R/W	°F	hdlm_level3	AV:405	0 TO 40	HTDOLEV3

## APPENDIX E — BACNET POINTS LIST

### ANALOG VALUE (AV) POINTS (CONT)

POINT DESCRIPTION	POINT ACCESS	UNITS	BACnet OBJECT NAME	BACnet ID	VALUE RANGE	CCN POINT EQUIVALENT
Heat Low Suc Lvl Offset	R/W	°F	sstofset	AV:464	0 TO 100	SSTOFSET
Heat Minimum Off Time	R/W	sec	h_minoff	AV:235	60 TO 600	H_MINOFF
Heat Minimum On Time	R/W	sec	h_minon	AV:236	60 TO 600	H_MINON
Heat Mode Select T.guard	READ ONLY	sec	ht_sel_timeguard	AV:45	0 TO 65535	HEATMSTG
Heat Setpoint in Effect	READ ONLY	°F	hsp_eff	AV:243	40 TO 80	HSP_EFF
Heat Shed 1 demand band	R/W		heatsh1	AV:6011	0 TO 55	HEATSH1
Heat Shed 2 demand band	R/W		heatsh2	AV:6012	0 TO 55	HEATSH2
Heat Shed 3 demand band	R/W		heatsh3	AV:6013	0 TO 55	HEATSH3
Heat Space Demand Trend	READ ONLY		htdtrend	AV:244	-99 TO 99	HTDTREND
Heat Stage 1 Reset Count	READ ONLY		rs_htr_1	AV:106	0 TO 65535	RS_HTR_1
Heat Stage 1 Run Hours	READ ONLY	hrs	hour_ht_1	AV:54	0 TO 999999	HR_HTR_1
Heat Stage 1 Starts	READ ONLY		st_htr_1	AV:142	0 TO 999999	ST_HTR_1
Heat Stage 1 Timeguard	READ ONLY	sec	timgd_h1	AV:173	0 TO 600	TIMGD_H1
Heat Stage 2 Reset Count	READ ONLY		rs_htr_2	AV:107	0 TO 65535	RS_HTR_2
Heat Stage 2 Run Hours	READ ONLY	hrs	hour_ht_2	AV:55	0 TO 999999	HR_HTR_2
Heat Stage 2 Starts	READ ONLY		st_htr_2	AV:143	0 TO 999999	ST_HTR_2
Heat Stage 2 Timeguard	READ ONLY	sec	timgd_h2	AV:50	0 TO 600	TIMGD_H2
Heat-Cool Setpoint Gap	R/W	°F	hcsp_gap	AV:238	2 TO 10	HCSASP
Heating Fan-Off Delay	R/W	sec	heat_fod	AV:241	10 TO 600	HEAT_FOD
Heating Lockout Temp	R/W	°F	oatheat	AV:8033	40 TO 125	OATHEAT
Heating Space Demand	READ ONLY	°F delta	heat_dmd	AV:240	-100 TO 100	HEAT_DMD
High Cool Demand On	R/W	°F	dmdhcon	AV:215	0.5 TO 20	DMDHCON
High FreeCool SAT Setpnt	R/W	°F	high_cool_sasp	AV:237	40 TO 80	HCSASP
High Heat Demand On	R/W	°F	dmdhhon	AV:217	0.5 TO 20	DMDHHON
IAQ Assigned Channel	R/W		iaq_channel	AV:7	0 TO 3	IAQ_CHAN
IAQ DCV Curve - Pos 1	READ ONLY	%	aq_pos1	AV:196	0 TO 1	AQ_POS1
IAQ DCV Curve - Pos 2	READ ONLY	%	aq_pos2	AV:197	0 TO 1	AQ_POS2
IAQ DCV Curve - Pos 3	READ ONLY	%	aq_pos3	AV:198	0 TO 1	AQ_POS3
IAQ DCV Curve - Speed 1	READ ONLY	%	aq_spd1	AV:199	0 TO 1	AQ_SPD1
IAQ DCV Curve - Speed 2	READ ONLY	%	aq_spd2	AV:200	0 TO 1	AQ_SPD2
IAQ DCV Curve - Speed 3	READ ONLY	%	aq_spd3	AV:201	0 TO 1	AQ_SPD3
IAQ DCV Curve Offset	READ ONLY	%	iaq_offs	AV:245	0 TO 1	IAQ_OFFS
IAQ Position at Max Fan	R/W	%	iaqminp	AV:246	0 TO 1	IAQMINP
IAQ Purge Curve - Pos 1	READ ONLY	%	aqp_pos1	AV:358	0 TO 1	AQP_POS1
IAQ Purge Curve - Pos 2	READ ONLY	%	aqp_pos2	AV:359	0 TO 1	AQP_POS2
IAQ Purge Curve - Pos 3	READ ONLY	%	aqp_pos3	AV:360	0 TO 1	AQP_POS3
IAQ Purge Curve - Speed1	READ ONLY	%	aqp_spd1	AV:361	0 TO 1	AQP_SPD1
IAQ Purge Curve - Speed2	READ ONLY	%	aqp_spd2	AV:362	0 TO 1	AQP_SPD2
IAQ Purge Curve - Speed3	READ ONLY	%	aqp_spd3	AV:363	0 TO 1	AQP_SPD3
IAQ Purge Curve Offset	READ ONLY	%	aqp_offs	AV:364	0 TO 1	AQP_OFFS
IAQ Sensor Value at 20mA	R/W	PPM	iaq_20ma	AV:12	0 TO 5000	IAQ_20MA
IAQ Sensor Value at 4mA	R/W	PPM	iaq_4ma	AV:13	0 TO 5000	IAQ_4MA
IDF Commanded RPM	R/W	RPM	fspd_rpm	AV:8048	0 TO 5000	FSPD_RPM
IDF Free Cool Speed-RPM	R/W	RPM	rpm_fcl	AV:8050	0 TO 5000	RPM_FCL
IDF Heat Speed-RPM	R/W	RPM	rpm_heat	AV:8052	0 TO 5000	RPM_HEAT
IDF High Cool Speed-RPM	R/W	RPM	rpm_hcl	AV:8051	0 TO 5000	RPM_HCL
IDF Low Cool Speed-RPM	R/W	RPM	rpm_lcl	AV:8053	0 TO 5000	RPM_LCL
IDF Maximum Fan Speed	R/W	%	speed_max	AV:36	0.8 TO 1	SPEEDMAX
IDF Vent Speed-RPM	R/W	RPM	rpm_vent	AV:8054	0 TO 5000	RPM_VENT
Indoor Air Quality Level	R/W	PPM	iaq	AV:1009	0 TO 5000	IAQ
Indoor Fan Reset Count	READ ONLY		rs_idf	AV:108	0 TO 65535	RS_IDF
Indoor Fan Run Hours	READ ONLY	hrs	hour_idf	AV:56	0 TO 999999	HR_IDF
Indoor Fan Speed Test	R/W	%	s_idfspd	AV:119	0 TO 1	S_IDFSPD
Indoor Fan Starts	READ ONLY		st_idf	AV:144	0 TO 999999	ST_IDF
Linkage CCN Bus number	R/W		lnk_supb	AV:272	0 TO 239	LNK_SUPB
Linkage CCN element #	R/W		lnk_supe	AV:273	0 TO 239	LNK_SUPE
Linkage Cooling Required	READ ONLY	°F	lnk_creq	AV:257	0 TO 30	LNK_CREQ
Linkage Damper Position	READ ONLY	%	lnk_dpos	AV:258	0 TO 1	LNK_DPOS
Linkage Equipment Mode	READ ONLY		lnk_mode	AV:261	0 TO 8	LNK_MODE
Linkage Heating Required	READ ONLY	°F	lnk_hreq	AV:259	0 TO 30	LNK_HREQ

## APPENDIX E — BACNET POINTS LIST

### ANALOG VALUE (AV) POINTS (CONT)

POINT DESCRIPTION	POINT ACCESS	UNITS	BACnet OBJECT NAME	BACnet ID	VALUE RANGE	CCN POINT EQUIVALENT
Linkage Maximum Airflow	READ ONLY		lnk_mair	AV:260	0 TO 5000	LNK_MAIR
Linkage Optimal Start	READ ONLY	min	lnk_opst	AV:267	0 TO 180	LNK_OPST
Linkage Space Air Qual.	READ ONLY	PPM	lnk_siaq	AV:270	0 TO 2000	LNK_SIAQ
Liquid Line Valve Starts	READ ONLY		st_llsv	AV:8059	0 TO 999999	ST_LLSV
LiquidLine Valve On Time	R/W	sec	llsv_ct	AV:463	0 TO 300	LLSV_CT
LiquidLineValv Reset Cnt	READ ONLY		rs_llsv	AV:8060	0 TO 65535	RS_LLSV
LiquidLineValv Run Hours	READ ONLY	hrs	hr_llsv	AV:8058	0 TO 999999	HR_LLSV
Linkage Space RH	READ ONLY	%	lnk_sprh	AV:271	0 TO 1	LNK_SPRH
Linkage Start Bias time	R/W	min	lnk_sbt	AV:269	0 TO 180	LNK_SBT
Linkage static pressure	READ ONLY	IN_H2O	link_ahu_static	AV:312	-5 TO 5	LNK_DSP
Linkage Supply air temp	READ ONLY	°F	lnk_sat	AV:268	-40 TO 240	LNK_SAT
Local Std Time offset	R/W	min	utc_ofst	AV:191	-780 TO 780	UTC_OFST
Low Charge Disable Temp	R/W	°F	loch_lot	AV:276	-40 TO 50	LOCH_LOT
Low Cool Demand Off	R/W	°F	dmdlcoff	AV:218	-1 TO 2	DMDLCOFF
Low Cool Demand On	R/W	°F	dmdlcon	AV:219	-1 TO 2	DMDLCON
Low Cool Lockout Temp	R/W	°F	lclcksp	AV:8031	-20 TO 60	LCLOCKSP
Low Heat Demand Off	R/W	°F	dmdlhoff	AV:220	-1 TO 2	DMDLHOFF
Low Heat Demand On	R/W	°F	dmdlhon	AV:221	-1 TO 2	DMDLHON
Low Refrig Charge Level	R/W	PSI	locharge	AV:277	0 TO 150	LOCHARGE
LowFree Cool SAT Setpnt	R/W	°F	low_cool_sasp	AV:254	40 TO 80	LCSASP
Max Allowed Cool Stages	R/W		max_cstgs	AV:278	0 TO 3	MAXCSTGS
Max Allowed Heat Stages	R/W		max_hstgs	AV:279	0 TO 2	MAXHSTGS
Max Enthalpy OA limit	R/W	BTU_LB	max_enth	AV:44	1.0f TO 99.0f	FREEMAXE
Max Fan Speed Run Hours	READ ONLY	hrs	hour_max_fan	AV:57	0 TO 999999	HR_MAXF
Max IDF Spd Resets Count	READ ONLY		rs_maxf	AV:109	0 TO 65535	RS_MAXF
Max IDF Speed Starts	READ ONLY		st_maxf	AV:145	0 TO 999999	ST_MAXF
Max OAT for 3 Heat Stags	R/W	°F	ht2lctmp	AV:8039	-20 TO 60	HT2LCTMP
Mech Cool Reset Count	READ ONLY		rs_mechc	AV:8069	0 TO 65535	RS_MECHC
Mech Heat Reset Count	READ ONLY		rs_mecht	AV:8066	0 TO 65535	RS_MECHT
Mechanical Cool Starts	READ ONLY		st_mechc	AV:8068	0 TO 999999	ST_MECHC
Mechanical Heat Starts	READ ONLY		st_mecht	AV:8065	0 TO 999999	ST_MECHT
MechanicalCool Run Hours	READ ONLY	hrs	hr_mechc	AV:8067	0 TO 999999	HR_MECHC
MechanicalHeat Run Hours	READ ONLY	hrs	hr_mecht	AV:8064	0 TO 999999	HR_MECHT
Medium Cool Demand On	R/W	°F	dmdmcon	AV:223	0.5 TO 20	DMDMCON
Min Pos - Default Pos 1	READ ONLY	%	mp_dpos1	AV:319	0 TO 1	MP_DPOS1
Min Pos - Default Pos 2	READ ONLY	%	mp_dpos2	AV:290	0 TO 1	MP_DPOS2
Min Pos - Default Pos 3	READ ONLY	%	mp_dpos3	AV:320	0 TO 1	MP_DPOS3
Min Pos - Default Speed1	READ ONLY	%	mp_dspd1	AV:321	0 TO 1	MP_DSPD1
Min Pos - Default Speed2	READ ONLY	%	mp_dspd2	AV:322	0 TO 1	MP_DSPD2
Min Pos - Default Speed3	READ ONLY	%	ms_dspd3	AV:323	0 TO 1	MP_DSPD3
Min Pos - User Pos 1	R/W	%	mp_upos1	AV:329	0 TO 1	MP_UPOS1
Min Pos - User Pos 2	R/W	%	mp_upos2	AV:330	0 TO 1	MP_UPOS2
Min Pos - User Pos 3	R/W	%	mp_upos3	AV:331	0 TO 1	MP_UPOS3
Min Pos - User Speed 1	R/W	%	mp_uspd1	AV:222	0 TO 1	MP_USPD1
Min Pos - User Speed 2	R/W	%	mp_uspd2	AV:5	0 TO 1	MP_USPD2
Min Pos - User Speed 3	R/W	%	mp_uspd3	AV:138	0 TO 1	MP_USPD3
Min Pos Curve - Pos 1	READ ONLY	%	mp_pos1	AV:324	0 TO 1	MP_POS1
Min Pos Curve - Pos 2	READ ONLY	%	mp_pos2	AV:325	0 TO 1	MP_POS2
Min Pos Curve - Pos 3	READ ONLY	%	mp_pos3	AV:326	0 TO 1	MP_POS3
Min Pos Curve - Speed 1	READ ONLY	%	mp_spd1	AV:327	0 TO 1	MP_SPD1
Min Pos Curve - Speed 2	READ ONLY	%	mp_spd2	AV:15	0 TO 1	MP_SPD2
Min Pos Curve - Speed 3	READ ONLY	%	mp_spd3	AV:328	0 TO 1	MP_SPD3
Min Position in Effect	R/W	%	min_pos	AV:412	0 TO 1	MIN_POS
Min Time BTWN Defrosts	R/W	min	mindfint	AV:8040	30 TO 120	MINDFINT
Mins until next occupied	READ ONLY	min	mintiloc	AV:175	-1 TO 10080	MINTILOC
Momentary Setpoint Adj	R/W	°F delta	moset	AV:6022	0 TO 20	MOSET
Momentary TLO Adjustment	R/W	sec	motlo	AV:6025	0 TO 14400	MOTLO
Network IAQ Value	R/W	PPM	iaq_net	AV:7001	0 TO 5000	IAQ_NET
Network OACFM Value	R/W	CFM	ocfm_net	AV:371	0 TO 5000	OCFM_NET

## APPENDIX E — BACNET POINTS LIST

### ANALOG VALUE (AV) POINTS (CONT)

POINT DESCRIPTION	POINT ACCESS	UNITS	BACnet OBJECT NAME	BACnet ID	VALUE RANGE	CCN POINT EQUIVALENT
Network OAQ Value	R/W	PPM	oaq_net	AV:7002	0 TO 5000	OAQ_NET
Network OARH Value	R/W	%	oarh_net	AV:7003	0 TO 1	OARH_NET
Network OAT Value	R/W	°F	oat_net	AV:7007	-40 TO 245	OAT_NET
Network RARH Value	R/W	%	rarh_net	AV:7004	0 TO 1	RARH_NET
Network Return Air Temp	R/W	°F	rat_net	AV:7005	-40 TO 245	RAT_NET
Network Space Temp Value	R/W	°F	spt_net	AV:7006	-40 TO 245	SPT_NET
Network SPRH Value	R/W	%	sprh_net	AV:376	0 TO 1	SPRH_NET
Next Occupied Time	READ ONLY	min	nxtoctim	AV:176	-1 TO 10080	NXTOCTIM
Next Unoccupied Time	READ ONLY	min	nxtuntim	AV:177	-1 TO 10079	NXTUNTIM
Number of Active Alerts	READ ONLY		num_active_alerts	AV:334	0 TO 100	NUMALRTS
Number of Active Faults	READ ONLY		num_active_faults	AV:335	0 TO 100	NUMFLTS
Number Of Heating Stages	R/W		numhstgs	AV:284	0 TO 2	NUMHSTGS
OA Quality Level	R/W	PPM	oaq	AV:1012	0 TO 5000	OAQ
OA Relative Humidity	R/W	%	oarh	AV:1022	0 TO 1	OARH
OACFM Assigned Channel	R/W		ocfmchan	AV:370	0 TO 3	OCFMCHAN
OACFM at 4MA	R/W	CFM	ocfm_4ma	AV:369	0 TO 5000	OCFM_4MA
OACFM Value at 20mA	R/W	CFM	ocfm20ma	AV:417	0 TO 5000	OCFM20MA
OAQ Assigned Channel	R/W		oaq_channel	AV:426	0 TO 3	OAQ_CHAN
OARH Assigned Channel	R/W		oarh_channel	AV:23	0 TO 3	OARHCHAN
OARH Sensor Val. at 20mA	R/W	%	oarh_20ma	AV:22	0.6 TO 1.0	OARH20MA
OARH Sensor Value at 4mA	R/W	%	oarh_4ma	AV:21	0 TO 0.5	OARH_4MA
OATLimitForSupAirTemp	R/W	°F	oatstemp	AV:424	-40 TO 125	OATSTEMP
Object instance for IAQ	R/W		objiaq	AV:8008	0 TO 9999	OBJIAQ
Object instance for OAQ	R/W		objoaq	AV:8009	0 TO 9999	OBJOAOQ
Object instance for OARH	R/W		objoarh	AV:8011	0 TO 9999	OBJOARH
Object instance for OAT	R/W		objoat	AV:8010	0 TO 9999	OBJOAT
Object instance for RARH	R/W		objrarh	AV:8012	0 TO 9999	OBJRARH
Object instance for RAT	R/W		objrat	AV:8013	0 TO 9999	OBJRAT
Object instance for SPRH	R/W		objsprh	AV:8029	0 TO 9999	OBJSPRH
Object instance for SPT	R/W		objspst	AV:8014	0 TO 9999	OBJSPT
Occ Cooling Required	READ ONLY	°F	lnk_ocrq	AV:263	0 TO 30	LNK_OCRQ
Occ Heating required	READ ONLY	°F	lnk_ohrq	AV:265	0 TO 30	LNK_OHRQ
Occupied Cool Setpoint	R/W	°F	ocsp	AV:288	55 TO 80	OCSP
Occupied Heat Setpoint	R/W	°F	ohsp	AV:289	55 TO 80	OHSP
Occupied Setpoint Gap	R/W		odb	AV:6003	0 TO 10	ODB
Occupied SPRH Setpoint	READ ONLY	%	sprh_osp	AV:367	0.10 TO 1	SPRH_OSP
Occupied Zone Setpoint	R/W	°F	osp	AV:6002	40 TO 80	OSP
ODF High Speed Time	R/W	sec	minodftm	AV:280	0 TO 300	MINODFTM
ODF Relay Resets Counts	READ ONLY		rs_ofr	AV:8044	0 TO 65535	RS_OFR
ODF Relay Run Hours	READ ONLY	hrs	hour_ofr	AV:8043	0 TO 999999	HR_OFR
ODF Relay Starts	READ ONLY		st_ofr	AV:8045	0 TO 999999	ST_OFR
Outdoor Air Enthalpy	R/W	BTU_LB	oa_enth	AV:76	-9.6f TO 334.2f	OA_ENTH
outdoor Air in CFM	R/W	CFM	oacfm	AV:416	0 TO 5000	OACFM
Outdoor Air Temp Sensor	READ ONLY	°F	oat_loc	AV:286	-40 TO 245	OAT_LOC
Outdoor Air Temperature	R/W	°F	oa_temp	AV:1003	-40 TO 245	OAT
P.Exhaust 1 Curve Offset	READ ONLY	%	pe1_offs	AV:317	0 TO 1	PE1_OFFS
P.Exhaust 1 Resets Count	READ ONLY		rs_pe_1	AV:113	0 TO 65535	RS_PE_1
P.Exhaust 2 Curve Offset	READ ONLY	%	pe2_offs	AV:229	0 TO 1	PE2_OFFS
P.Exhaust 2 Resets Count	READ ONLY		rs_pe_2	AV:114	0 TO 65535	RS_PE_2
PE Stage 1 At Max Speed	R/W	%	pe1_pmax	AV:343	0 TO 1	PE1_PMAX
PE Stage 2 At Max Speed	R/W	%	pe2_pmax	AV:344	0 TO 1	PE2_PMAX
PE Turn Off Dead band	R/W	%	pe_offdb	AV:316	0 TO 1	PE_OFFDB
PE1 Assigned Relay	R/W		pe1_channel	AV:365	0 TO 2	PE1_CHAN
PE2 Assigned Relay	R/W		pe2_channel	AV:366	0 TO 2	PE2_CHAN
Pilot Space Temp Value	R/W	°F	space_temp	AV:2007	-40 TO 245	SPT
Power Cycle Counts	READ ONLY		st_por	AV:150	0 TO 999999	ST_POR
Power Cycle Resets Count	READ ONLY		rs_por	AV:115	0 TO 65535	RS_POR
Power Exhaust 1 - Pos 1	READ ONLY	%	pe1_pos1	AV:345	0 TO 1	PE1_POS1
Power Exhaust 1 - Pos 2	READ ONLY	%	pe1_pos2	AV:346	0 TO 1	PE1_POS2
Power Exhaust 1 - Pos 3	READ ONLY	%	pe1_pos3	AV:347	0 TO 1	PE1_POS3

## APPENDIX E — BACNET POINTS LIST

### ANALOG VALUE (AV) POINTS (CONT)

POINT DESCRIPTION	POINT ACCESS	UNITS	BACnet OBJECT NAME	BACnet ID	VALUE RANGE	CCN POINT EQUIVALENT
Power Exhaust 1 - Speed1	READ ONLY	%	pe1_spd1	AV:348	0 TO 1	PE1_SPD1
Power Exhaust 1 - Speed2	READ ONLY	%	pe1_spd2	AV:349	0 TO 1	PE1_SPD2
Power Exhaust 1 - Speed3	READ ONLY	%	pe1_spd3	AV:350	0 TO 1	PE1_SPD3
Power Exhaust 1 Starts	READ ONLY		st_pe_1	AV:148	0 TO 999999	ST_PE_1
Power Exhaust 2 - Pos 1	READ ONLY	%	pe2_pos1	AV:351	0 TO 1	PE2_POS1
Power Exhaust 2 - Pos 2	READ ONLY	%	pe2_pos2	AV:352	0 TO 1	PE2_POS2
Power Exhaust 2 - Pos 3	READ ONLY	%	pe2_pos3	AV:353	0 TO 1	PE2_POS3
Power Exhaust 2 - Speed1	READ ONLY	%	pe2_spd1	AV:354	0 TO 1	PE2_SPD1
Power Exhaust 2 - Speed2	READ ONLY	%	pe2_spd2	AV:355	0 TO 1	PE2_SPD2
Power Exhaust 2 - Speed3	READ ONLY	%	pe2_spd3	AV:356	0 TO 1	PE2_SPD3
Power Exhaust 2 Starts	READ ONLY		st_pe_2	AV:149	0 TO 999999	ST_PE_2
Power Exhaust1 Run Hours	READ ONLY	hrs	hour_pe_1	AV:61	0 TO 999999	HR_PE_1
Power Exhaust2 Run Hours	READ ONLY	hrs	hour_pe_2	AV:62	0 TO 999999	HR_PE_2
Preocc Purge Duration	R/W	min	iaqptime	AV:252	5 TO 120	IAQPTIME
Preocc Purge Lockout OAT	R/W	°F	iaqp_la	AV:248	0 TO 70	IAQP_LA
Previous Unoccupied Time	READ ONLY	min	prvuntim	AV:182	-1 TO 10079	PRVUNTIM
RA Relative Humidity	R/W	%	rarh	AV:30	0 TO 1	RARH
RARH Assigned Channel	R/W		rarh_channel	AV:33	0 TO 3	RARHCHAN
RARH Sensor Value @ 20mA	R/W	%	rarh_20ma	AV:32	0.0f TO 1	RARH20MA
RARH Sensor Value at 4mA	R/W	%	rarh_4ma	AV:31	0 TO 1.0f	RARH_4MA
Req Compr DehumStgs	R/W		reqdstgs	AV:413	0 TO 10	REQDSTGS
Requested Cooling Stages	READ ONLY		req_cstgs	AV:292	0 TO 3	REQCSTGS
Requested Damper Pos	R/W	%	dmpr_req_pos	AV:4006	0 TO 1	DAMPREQ
Requested Heating Stages	READ ONLY		reqhstgs	AV:293	0 TO 2	REQHSTGS
Requested IDF Speed	READ ONLY	%	req_fan_spd	AV:35	0 TO 1	RQFANSPD
Reset Device	R/W		resetdev	AV:184	0 TO 1	RESETDEV
Restore Completion Time	READ ONLY		rstcomtm	AV:337	0 TO 65535	RSTCOMTM
Return Air Enthalpy	R/W	BTU_LB	ra_enth	AV:95	-9.6f TO 334.2f	RA_ENTH
Return Air Temp Sensor	READ ONLY	°F	rat_loc	AV:291	-40 TO 245	RAT_LOC
Return Air Temperature	R/W	°F	ra_temp	AV:1010	-40 TO 245	RAT
ReverseSolValv Run Hours	READ ONLY	hrs	hr_rvs_a	AV:8061	0 TO 999999	HR_RVS_A
ReverseSolValv Run Hours	READ ONLY	hrs	hr_rvs_a	AV:8061	0 TO 999999	HR_RVS_A
ReverseSolValv Starts	READ ONLY		st_rvs_a	AV:8062	0 TO 999999	ST_RVS_A
RevSolValv Reset Count	READ ONLY		rs_rvs_a	AV:8063	0 TO 65535	RS_RVS_A
SA Tempering Set point	R/W	°F	sup_air_temp_setpt	AV:411	-20 TO 60	SATEMPSP
Service Test Reset Count	READ ONLY		rs_stest	AV:116	0 TO 65535	RS_STEST
Service Test Run Hours	READ ONLY	hrs	hour_serv_tst	AV:63	0 TO 999999	HR_STEST
Service Test Starts	READ ONLY		st_stest	AV:151	0 TO 999999	ST_STEST
Setpoint adjustment	R/W	°F delta	setadj	AV:6021	0 TO 1	SETADJ
Single Zone Setpoint	R/W	°F	zonespt	AV:6001	55 TO 80	ZONESPT
Software Build Time	READ ONLY		fw_bldtm	AV:169	0 TO 4294967295	FW_BLDTM
Space Cooling Demand	READ ONLY	°F delta	cool_dmd	AV:206	-100 TO 100	COOL_DMD
Space Demand Time Guard1	R/W	sec	tdmd_tg1	AV:311	60 TO 600	TDMD_TG1
Space Demand Time Guard2	R/W	sec	tdmd_tg2	AV:186	0 TO 600	TDMD_TG2
Space Demand Time Guard3	R/W	min	tdmd_tg3	AV:187	5 TO 120	TDMD_TG3
Space RH	R/W	%	space_rh	AV:1011	0 TO 1	SPRH
Space RH Deadband	R/W	%	sprh_db	AV:368	0 TO 1	SPRH_DB
Space Temperature	R/W	°F	space_t	AV:296	-40 TO 245	SPACE_T
Space Temperature Offset	R/W	°F delta	stpt_adj	AV:1006	-10 TO 10	SPTO
Space Temperature Sensor	READ ONLY	°F	spt_loc	AV:297	-40 TO 245	SPT_LOC
SPRH Assigned Channel	R/W		sprhchan	AV:372	0 TO 3	SPRHCHAN
SPRH Sensor Value @ 20mA	R/W	%	sprh_20ma	AV:373	0.6 TO 1	SPRH20MA
SPRH Sensor Value at 4mA	R/W	%	sprh_4ma	AV:375	0 TO 0.5	SPRH_4MA
SPT Offset Range (+/-)	R/W	°F	spto_rng	AV:298	0 TO 5	SPTO_RNG
SPT Offset Total diff	READ ONLY	°F delta	sptodiff	AV:6020	0 TO 20	SPTODIFF
Std Barometric Pressure	R/W	IN_HG_OF_KPAG	std_bar_p	AV:303	10 TO 35	STD_BARP
Supply Air Temp Trend	READ ONLY		sattrend	AV:342	-285 TO 285	SATTREND
Supply Air Temperature	READ ONLY	°F	sa_temp	AV:1008	-40 TO 245	SAT
System Demand	READ ONLY		sys_demand	AV:37	0 TO 255	SYS_DMD
System Demand Alert	R/W		sys_dmd_alert	AV:227	0 TO 65535	SYSDMDAT

## APPENDIX E — BACNET POINTS LIST

### ANALOG VALUE (AV) POINTS (CONT)

POINT DESCRIPTION	POINT ACCESS	UNITS	BACnet OBJECT NAME	BACnet ID	VALUE RANGE	CCN POINT EQUIVALENT
System Touch AI for SPRH	R/W		aistsprh	AV:8027	0 TO 9999	AISTSPRH
System Touch AI for SPT	R/W		aistspt	AV:8026	0 TO 9999	AISTSPT
System Touch Device Inst	R/W		devst	AV:8024	0 TO 4194303	DEVST
System Touch Poll Rate	R/W		pollst	AV:8025	10 TO 60	POLLST
System Touch RH Value	R/W	%	strh_net	AV:8022	0 TO 1	STRH_NET
System Touch Temp Value	R/W	°F	stst_net	AV:8023	-40 TO 245	STST_NET
T24 Heat/Cool End Delay	R/W	min	t24chdly	AV:305	0 TO 60	T24CHDLY
T24 Min Diff in RAT-OAT	R/W	°F	t24ratdf	AV:307	5 TO 20	T24RATDF
T24 Test Maximum Pos	R/W	%	t24tstmx	AV:310	0.0f TO 1.0f	T24TSTMX
T24 Test Minimum Pos	R/W	%	t24tstmn	AV:309	0.0f TO 1.0f	T24TSTMN
T24Econ Min Move for SAT	R/W	%	t24ecsts	AV:306	0.1 TO 0.2	T24ECSTS
Timed Override Duration	R/W	hrs	otl_cfg	AV:179	0 TO 4	OTL_CFG
Timed Override Hours	R/W	min	ovr_ext	AV:180	0 TO 240	OVR_EXT
TLO cancel	R/W	sec	tlocan	AV:6029	0 TO 10	TLOCAN
TLO limit	R/W	sec	tlolim	AV:6027	0 TO 14400	TLOLIM
TLO Time Remaining	READ ONLY	sec	tlorem	AV:6028	0 TO 14400	TLOREM
UFC PreOcc Time	R/W	min	ufctime	AV:105	1 TO 999	UFCTIME
Unit Full Load Run Hours	READ ONLY	hrs	hour_full_ld	AV:52	0 TO 999999	HR_LOAD
Unit Full Load Starts	READ ONLY		st_fload	AV:140	0 TO 999999	ST_FLOAD
Unit Startup Delay	R/W	sec	startdly	AV:153	10 TO 600	STARTDLY
Unocc Free Cool Low Temp	R/W	°F	oatlufc	AV:287	-30.0f TO 70.0f	OATLUFC
Unoccupied Cool Setpoint	R/W	°F	ucsp	AV:8	65 TO 95	UCSP
Unoccupied Heat Setpoint	R/W	°F	uhsp	AV:178	40 TO 80	UHSP
Unoccupied Setpoint Gap	R/W		udb	AV:6004	0 TO 55	UDB
Unoccupied SPRH Setpoint	READ ONLY	%	sprh_usp	AV:461	0.10 TO 1	SPRH_USP
UnoccupiedZone Setpoint	R/W	°F	usp	AV:6005	40 TO 95	USP
User Min Pos Pnt 1 Valid	READ ONLY		mp_upt1	AV:332	0 TO 1	MP_UPT1
User Min Pos Pnt 2 Valid	READ ONLY		mp_upt2	AV:333	0 TO 1	MP_UPT2
User Min Pos Pnt 3 Valid	READ ONLY		mp_upt3	AV:214	0 TO 1	MP_UPT3
User Password	R/W		password	AV:181	0 TO 9999	PASSWORD
Value of Prime variable	READ ONLY		prime_v	AV:39	-40 TO 245	PRIME_V
Vent IDF Resets Count	READ ONLY		rs_ventf	AV:117	0 TO 65535	RS_VENTF
Vent IDF Run Hours	READ ONLY	hrs	hour_vent_fan	AV:64	0 TO 999999	HR_VENTF
Ventilation Fan Starts	READ ONLY		st_ventf	AV:152	0 TO 999999	ST_VENTF
Zone Sensor 1 Address	R/W		zsaddr1	AV:8034	0x00 TO 0xFF	ZSADDR1
Zone Sensor 2 Address	R/W		zsaddr2	AV:8035	0x00 TO 0xFF	ZSADDR2
Zone sensor 3 address	R/W		zsaddr3	AV:8036	0x00 TO 0xFF	ZSADDR3
Zone sensor 4 address	R/W		zsaddr4	AV:8037	0x00 TO 0xFF	ZSADDR4
Zone sensor 5 address	R/W		zsaddr5	AV:8038	0x00 TO 0xFF	ZSADDR5
ZS Zone Temp	R/W	°F	ZSZoneTemp	AV:1905	-40 TO 245	ZSZT

## APPENDIX E — BACNET POINTS LIST

### BINARY VALUE (BV) POINTS

POINT DESCRIPTION	POINT ACCESS	UNITS	BACnet OBJECT NAME	BACnet ID	VALUE RANGE	CCN POINT EQUIVALENT
2-Pos Damper/ERV relay	R/W		erv_2pos	BV:6002	0 TO 1	ERV_2POS
2Position/ERV Relay Test	R/W		s_erv2p	BV:457	0 TO 1	S_ERV2P
A051 Cmp off expected ON	R/W		a_caoff	BV:181	0 TO 1	
Act Mech Disconnect Alrt	R/W		a_dnmemd	BV:218	0 TO 1	1
Air Quality CO2 Alerts	R/W		co2s_al	BV:307	0 TO 1	CO2S_AL
Alarm Output Relay State	R/W		equip_alarm	BV:7048	0 TO 1	ALMOUT
Alarm Output Relay Test	R/W		s_alarm	BV:70	0 TO 1	S_ALARM
Alarm Reporting Enable	R/W		ALARMEN	BV:27	0 TO 1	ALARMEN
ALC Auto Id Scheme	R/W		auid	BV:106	0 TO 1	AUID
All Heat Stages Lockout	R/W		allhtloc	BV:122	0 TO 1	ALLHTLOC
AUTO INDEPENDENT TEST	R/W		autoindp	BV:163	0 TO 1	AUTOINDP
BACnet BMS Schedule	READ ONLY		bms_sced	BV:108	0 TO 1	BMS_SCED
BACnet ID Auto ID	R/W		bac_auid	BV:107	0 TO 1	BAC_AUID
BACnetCal Object Status	READ ONLY		calobjst	BV:110	0 TO 1	CALOBJST
Bad DD Point-OutOfRange	R/W		f_bad_dd	BV:243	0 TO 1	
CA1 DDF Fault	R/W		f_ca1ddf	BV:178	0 TO 1	
CA1 FTP alert	R/W		a_ca1ftp	BV:182	0 TO 1	
CA1 Rev Rotation alert	R/W		a_ca1rr	BV:179	0 TO 1	
CCH Relay 1 State	READ ONLY		cch_relay	BV:3	0 TO 1	CCHR1
Cir A DDF Fault	R/W		f_caddf	BV:168	0 TO 1	
Cir A HDP alert	R/W		a_cahdp	BV:172	0 TO 1	
Cir A HPS alert	R/W		a_cahps	BV:171	0 TO 1	
Cir A LDP Alert	R/W		a_caldp	BV:236	0 TO 1	
Cir A LSP Alert	R/W		a_calsp	BV:170	0 TO 1	
Cir A Press Ratio Alert	R/W		a_capr	BV:169	0 TO 1	
Cir A SSP out Rng Alert	R/W		a_badspa	BV:189	0 TO 1	
Cir.A High Pressure Sw	READ ONLY		circa_hps	BV:4	0 TO 1	CIRA_HPS
Circ A SDP Open Alert	R/W		a_opndpa	BV:191	0 TO 1	
Circ A SDP range alert	R/W		a_baddpa	BV:183	0 TO 1	
Circ A SDP Short Alert	R/W		a_shtdpa	BV:202	0 TO 1	
Circ A SSP Open Alert	R/W		a_opnspace	BV:200	0 TO 1	
Circuit A CMP A1 Loader	READ ONLY		cmpalena	BV:9	0 TO 1	COMP_ALD
Circuit A Compressor 1	READ ONLY		cmpa1ena	BV:5	0 TO 1	COMP_A1
Circuit A Locked Out	READ ONLY		ciralock	BV:128	0 TO 1	CIRALOCK
Circuit A SSP Shrt Alert	R/W		a_shtspa	BV:211	0 TO 1	
Ckt-A low charge fault	R/W		f_caloch	BV:167	0 TO 1	
Clear Alarm History	R/W		alarm_hist_clear	BV:32	0 TO 1	ALHISCLR
Cmp Bump Loader Test	R/W		s_bmpald	BV:64	0 TO 1	S_BMPALD
COFS Switch State	R/W		condensate_switch	BV:7028	0 TO 1	COFS
Compressor A1 Available	READ ONLY		ca1_aval	BV:123	0 TO 1	CA1_AVAL
Compressor A1 Locked Out	READ ONLY		ca1_lock	BV:124	0 TO 1	CA1_LOCK
Compressor Alerts	R/W		comp_alarm	BV:312	0 TO 1	COMP_AL
Compressor Bump A1 Test	R/W		s_bmpa1	BV:71	0 TO 1	S_BMPA1
CompressorStuck on Fault	R/W		f_cstuck	BV:241	0 TO 1	
Condensate Ovrflow fault	R/W		f_cofs	BV:273	0 TO 1	
CoolDemandLimiting	R/W		cooldmdLimit	BV:435	0 TO 1	CDMLMOFF
Cooling W/Comp.A1 Test	R/W		s_coola1	BV:74	0 TO 1	S_COOLA1
Cooling W/Comp.ALD Test	R/W		s_cola1d	BV:79	0 TO 1	S_COLALD
Crankcase Heater 1 test	R/W		s_cchr1	BV:73	0 TO 1	S_CCHR1
Currently Occupied	R/W		occ_status	BV:2008	0 TO 1	OCCUPIED
Damper fdbk out of range	R/W		a_badec1	BV:184	0 TO 1	
Damper fdbk Short Alert	R/W		a_shtec1	BV:203	0 TO 1	
Damper Not Mod Alert	R/W		a_dnm	BV:215	0 TO 1	
Damper Stuck Closed Alrt	R/W		a_dnm_sc	BV:216	0 TO 1	
Damper Stuck Open Alert	R/W		a_dnm_so	BV:217	0 TO 1	
Defrost Mode Active	READ ONLY	enum	dfrstact	BV:467	0 TO 1	DFRSTACT
Defrost Switch	READ ONLY	enum	defrostswitch	BV:9002	0 TO 1	DFRST_SW
Defrost Test	R/W	enum	s_dfrst	BV:9004	0 TO 1	S_DFRST
Diff. Dry Bulb Control	R/W		dif_db_ena	BV:41	0 TO 1	DIFFBULB
Diff. Enthalpy Control	R/W		dif_enth_ena	BV:42	0 TO 1	DIFFENTH

## APPENDIX E — BACNET POINTS LIST

### BINARY VALUE (BV) POINTS (CONT)

POINT DESCRIPTION	POINT ACCESS	UNITS	BACnet OBJECT NAME	BACnet ID	VALUE RANGE	CCN POINT EQUIVALENT
dirty filter alert	R/W		a_dfilt	BV:214	0 TO 1	
Dirty Filter Alerts	R/W		filter_alarm	BV:7017	0 TO 1	FILT_AL
Dmpr fdbk Open Cir Alert	R/W		a_opnec1	BV:192	0 TO 1	
Dry Bulb Lockout	R/W		db_lock_out	BV:40	0 TO 1	DBLOCK
DST allowed?	R/W		dst_cfg	BV:93	0 TO 1	DST_CFG
DST currently active	READ ONLY		dst_actv	BV:92	0 TO 1	DST_ACTV
Econ Damper Calibration	R/W	enum	s_ecocal	BV:9008	0 TO 1	S_ECOCAL
Econ Damper Operational	READ ONLY		damp_good	BV:39	0 TO 1	DAMPGOOD
Econo Actual Position	R/W		dmpr_err	BV:21	0 TO 1	DAMP_ERR
Economizer Alerts	R/W		econ_alarm	BV:43	0 TO 1	ECON_AL
Economizer Cooling	R/W		a_t24ewc	BV:226	0 TO 1	
Economizer Not Cooling	R/W		a_t24enc	BV:224	0 TO 1	
Enthalpy Lockout	R/W		enth_lock_out	BV:44	0 TO 1	ENTHLOCK
Excess Outside Air Alert	R/W		a_t24eoa	BV:225	0 TO 1	
Fan Off When Cmded On	R/W		f_idfoff	BV:230	0 TO 1	
Fan On When Cmded Off	R/W		f_idfon	BV:231	0 TO 1	
Fan On When Occupied	R/W		occupied_fan	BV:46	0 TO 1	FANON_OC
fbdh sat locked out	READ ONLY		fbdsatlo	BV:439	0 TO 1	FBDSATLO
FBDH SST locked out	READ ONLY		fbdsstlo	BV:440	0 TO 1	FBDSSTLO
Filter Status Switch	R/W		flt_status	BV:1016	0 TO 1	FILTSTAT
Fire shutdown fault	R/W		f_fire	BV:242	0 TO 1	
Fire Shutdown Switch	R/W		firedown	BV:112	0 TO 1	FIREDOWN
FST Open Circuit Alert	R/W		a_opnfst	BV:193	0 TO 1	
FST out of Range Alert	R/W		a_badfst	BV:185	0 TO 1	
FST Sensor Error	R/W		fst_error	BV:49	0 TO 1	FST_ERR
FST Short Circuit Alert	R/W		a_shtfst	BV:204	0 TO 1	
General Status alert	R/W		a_gensw	BV:244	0 TO 1	
General Status Alerts	R/W		gens_al	BV:309	0 TO 1	GENS_AL
General Status fault	R/W		f_gensw	BV:265	0 TO 1	
General Status Switch	R/W		gen_status	BV:50	0 TO 1	GENSTAT
Hardware Failures Alerts	R/W		hw_al	BV:305	0 TO 1	HW_AL
Heat Stage 1 Available	READ ONLY		ht1_aval	BV:16	0 TO 1	HT1_AVAL
Heat Stage 1 Relay	READ ONLY		hs1	BV:10	0 TO 1	HEAT_1
Heat Stage 2 Available	READ ONLY		ht2_aval	BV:17	0 TO 1	HT2_AVAL
Heat Stage 2 Relay	READ ONLY		hs2	BV:11	0 TO 1	HEAT_2
HeatDemandLimiting	R/W		heatdmdLimit	BV:370	0 TO 1	HDMLMOFF
Heating Failure Alerts	R/W		heat_al	BV:306	0 TO 1	HEAT_AL
Heating Stage 1 Test	R/W		s_heat1	BV:76	0 TO 1	S_HEAT1
Heating Stage 2 Test	R/W		s_heat2	BV:77	0 TO 1	S_HEAT2
humidity ctrl is active	READ ONLY		humctr1a	BV:423	0 TO 1	
IAQ Open Circuit Alert	R/W		a_opniaq	BV:194	0 TO 1	
IAQ override enable	R/W		iaq_override_en	BV:445	0 TO 1	IAQOVREN
IAQ override sw state	R/W		iaqoverride_switch	BV:7030	0 TO 1	IAQ_OVRS
IAQ Preoccupancy Purge	R/W		iaqpurge	BV:20	0 TO 1	IAQPURGE
IAQ Sensor Error	R/W		iaq_err	BV:51	0 TO 1	IAQ_ERR
IAQ Short Circuit Alert	R/W		a_shtiaq	BV:205	0 TO 1	
IDF Manual Limit Fault	READ ONLY		f_idflsm	BV:278	0 TO 1	
IDF Manual Transition	R/W		s_idftrn	BV:78	0 TO 1	S_IDFTRN
IDF Operation Errors?	READ ONLY		idf_bad	BV:52	0 TO 1	IDFBAD
IDF Speed Override Flag	READ ONLY		sfan_hand_alarm	BV:7009	0 TO 1	FAN_OVRD
IDF Speed Reduction On	READ ONLY		fanred10	BV:7	0 TO 1	FANRED10
Ignition Failure Alert	R/W		a_noign	BV:222	0 TO 1	
In Pre-Occupancy Purge?	READ ONLY		preoccon	BV:38	0 TO 1	PREOCCON
Indoor Fan Alerts	R/W		idf_alarm	BV:45	0 TO 1	FAN_AL
Is IAQ Override Active?	READ ONLY		iaq_ovrd	BV:164	0 TO 1	IAQ_OVRD
Linkage Active	READ ONLY		link_active	BV:58	0 TO 1	LNK_ACT
LiqLine Solenoid Test	R/W	enum	s_llsv	BV:9007	0 TO 1	S_LLSV
Local Sched Occ Request	R/W		loc_occ	BV:95	0 TO 1	LOC_OCC
Low cooling locked out	READ ONLY		lc_lock	BV:317	0 TO 1	LC_LOCK
Low Discharge Diagnostic	R/W	enum	disldpal	BV:469	0 TO 1	DISLDPAL



## APPENDIX E — BACNET POINTS LIST

### BINARY VALUE (BV) POINTS (CONT)

POINT DESCRIPTION	POINT ACCESS	UNITS	BACnet OBJECT NAME	BACnet ID	VALUE RANGE	CCN POINT EQUIVALENT
Make Config Backup File	R/W		ddbckup	BV:129	0 TO 1	DDBCKUP
MBB 24VDC Alert	R/W		a_mbb24d	BV:247	0 TO 1	
MBB 5VDC Alert	R/W		a_mbb5dc	BV:248	0 TO 1	
MBB EEPROM failure fault	R/W		f_mbbbeep	BV:267	0 TO 1	
MBB Fuse 2 Fault	R/W		f_mbbf2	BV:268	0 TO 1	
MBB Fuse 3 Fault	R/W		f_mbbf3	BV:269	0 TO 1	
MBB low voltage Fault	R/W		f_mbblov	BV:270	0 TO 1	
MBB Ref Volt Fail Fault	R/W		f_mbbref	BV:271	0 TO 1	
MBB RNET Voltage Alert	R/W		a_mbb12d	BV:246	0 TO 1	
MBB zero crossing alert	R/W		a_mbb0x	BV:245	0 TO 1	
Mechanical Cool active?	READ ONLY		mechcool	BV:301	0 TO 1	MECHCOOL
Mechanical Heating	READ ONLY	enum	mecht_en	BV:465	0 TO 1	MECHT_EN
Mechanical Heating Test	R/W	enum	s_mecht	BV:9005	0 TO 1	S_MECHT
OACFM Alarm Relay	R/W		oacfm_rel_alarm	BV:371	0 TO 1	OACFM_AL
OACFM Open Circuit Alert	R/W		a_opnoac	BV:276	0 TO 1	
OACFM ShortCircuit Alert	R/W		a_shtoac	BV:277	0 TO 1	
OAQ Open Circuit Alert	R/W		a_opnoaq	BV:195	0 TO 1	
OAQ Short Circuit Alert	R/W		a_shtoaq	BV:206	0 TO 1	
OARH Open Circuit Alert	R/W		a_opnorh	BV:197	0 TO 1	
OARH Sensor Error	R/W		oarh_err	BV:60	0 TO 1	OARH_ERR
OARH Short Circuit Alert	R/W		a_shtorh	BV:208	0 TO 1	
OAT Open Circuit Alert	R/W		a_opnoat	BV:196	0 TO 1	
OAT out of Range Alert	R/W		a_badoat	BV:186	0 TO 1	
OAT Sensor Error	R/W		oat_error	BV:314	0 TO 1	OAT_ERR
OAT Short Circuit Alert	R/W		a_shtoat	BV:207	0 TO 1	
OAT Thermistor Alerts	R/W		oat_rel_alarm	BV:61	0 TO 1	OATRL_AL
ODF Speed Relay Test	R/W		s_ofrspd	BV:6001	0 TO 1	S_OFRSPD
Ok to fan based dehum	READ ONLY		oktofdb	BV:420	0 TO 1	OKTOFBD
Ok to Dehumidify?	READ ONLY		oktodhum	BV:422	0 TO 1	OKTODHUM
Ok to Preoccupancy Purge	READ ONLY		okpreocc	BV:35	0 TO 1	OKPREOCC
OK to Run Heat	READ ONLY		oktoheat	BV:36	0 TO 1	OKTOHEAT
OK to SupplyAirTempering	READ ONLY		oktotemp	BV:415	0 TO 1	OKTOTEMP
Ok to Unocc Free Cool?	READ ONLY		oktoufc	BV:37	0 TO 1	OKTOUFC
Ok to use compressors?	READ ONLY		okmechcl	BV:302	0 TO 1	OKMECHCL
OK to Use Free Cooling?	READ ONLY		ok_free_cl	BV:65	0 TO 1	OKFREECL
Outdoor Fan Speed Relay	R/W		ofr	BV:6000	0 TO 1	OFR
Percent Enable/Disable	R/W		perc_bac	BV:303	0 TO 1	PERC_BAC
Phase Monitor Fault	READ ONLY		f_phmon	BV:279	0 TO 1	
Power Exhaust 1 Relay	R/W		pe1	BV:15	0 TO 1	PE1
Power Exhaust 1 Test	R/W		s_pe_1	BV:82	0 TO 1	S_PE_1
Power Exhaust 2 Relay	R/W		pe2	BV:66	0 TO 1	PE2
Power Exhaust 2 Test	R/W		s_pe_2	BV:83	0 TO 1	S_PE_2
RARH Open Circuit Alert	R/W		a_opnrh	BV:199	0 TO 1	
RARH Sensor Error	R/W		rarh_err	BV:67	0 TO 1	RARH_ERR
RARH Short Circuit Alert	R/W		a_shtrh	BV:210	0 TO 1	
RAT Open Circuit Alert	R/W		a_opnrat	BV:198	0 TO 1	
RAT out of Range Alert	R/W		a_badrat	BV:187	0 TO 1	
RAT out of Range Alert	R/W		a_badsat	BV:188	0 TO 1	
RAT Sensor Error	R/W		rat_err	BV:68	0 TO 1	RAT_ERR
RAT Short Circuit Alert	R/W		a_shtrat	BV:209	0 TO 1	
Refrig Circuit Alerts	R/W		circuit_alarm	BV:313	0 TO 1	CKT_AL
Remote Occupancy Switch	R/W		remocc	BV:29	0 TO 1	REMOCC
Remote shutdown fault	R/W		f_remoft	BV:272	0 TO 1	
Remote Shutdown Switch	R/W		rem_shut	BV:9001	0 TO 1	REMSHUT
Reset All Current Alarms	R/W		alarm_reset	BV:33	0 TO 1	ALRESET
Reset Filter Timer	R/W		reset_filter_timer	BV:109	0 TO 1	RESETFLT
Rev.Val. Sole. Cir.A Tst	R/W	enum	s_rvs_a	BV:9006	0 TO 1	S_RVS_A
RH sensor failure Alert	R/W		rhs_al	BV:308	0 TO 1	RHS_AL
Rht Dischg Valve Rly Tst	R/W		s_rdv_a	BV:282	0 TO 1	S_RDV_A
Rollout without Heating	R/W		f_ronoht	BV:235	0 TO 1	

## APPENDIX E — BACNET POINTS LIST

### BINARY VALUE (BV) POINTS (CONT)

POINT DESCRIPTION	POINT ACCESS	UNITS	BACnet OBJECT NAME	BACnet ID	VALUE RANGE	CCN POINT EQUIVALENT
RUN AUTO COOLING TEST	R/W		autocool	BV:160	0 TO 1	AUTOCOOL
RUN AUTO HEATING TEST	R/W		autoheat	BV:161	0 TO 1	AUTOHEAT
RUN AUTO SYSTEM TEST	R/W		autosys	BV:162	0 TO 1	AUTOSYS
Run away heat fault	R/W		f_hstuck	BV:266	0 TO 1	0 TO 1
SAT Sensor Error	R/W		sat_err	BV:84	0 TO 1	SAT_ERR
SAT/RAT Sensor Alerts	R/W		sa_ra_alarm	BV:311	0 TO 1	SATRATAL
SDPA Sensor Error	R/W		sdpa_err	BV:63	0 TO 1	SDPA_ERR
Shut Down on IDF Failure	R/W		sfan_fail_alarm	BV:7008	0 TO 1	FATALFAN
Shutdown A1 First	R/W		sdwn_a1	BV:449	0 TO 1	SDWN_A1
Shutdown Loader First	R/W		sdwn_ald	BV:451	0 TO 1	SDWN_ALD
Smoke Purge Input	R/W		purge	BV:80	0 TO 1	PURGE
Space Sensors Alerts	R/W		space_alarm	BV:103	0 TO 1	SPACE_AL
SPRH Open Circuit Alert	R/W		a_opnsrh	BV:274	0 TO 1	
SPRH Short Circuit Alert	R/W		a_shtsrh	BV:275	0 TO 1	
SPT Open Circuit Alert	R/W		a_opnspt	BV:201	0 TO 1	
SPT Sensor Error	R/W		space_err	BV:7001	0 TO 1	SPT_ERR
SPT Short Circuit Alert	R/W		a_shtspt	BV:212	0 TO 1	
SPTO Sensor Error	R/W		stpt_err	BV:7002	0 TO 1	SPTO_ERR
SPToutofRangeAlert	R/W		a_badspt	BV:190	0 TO 1	
SSPA Sensor Error	R/W		sspa_err	BV:89	0 TO 1	SSPA_ERR
Start Config Restore	READ ONLY		ddrstre	BV:130	0 TO 1	DDRSTRE
Supply Air Temper Enable	R/W		sup_air_temp_en	BV:410	0 TO 1	SATEMPEN
System Demand Alarm	R/W		sys_dmd_alarm	BV:26	0 TO 1	SYSDMDAL
Temp Compensate Start On	READ ONLY		tcs_Act	BV:133	0 TO 1	TCS_ACT
Thermostat Alerts	R/W		tstat_al	BV:104	0 TO 1	TSTAT_AL
Thermostat G Input	R/W		g_input	BV:1021	0 TO 1	G
Thermostat W1 Input	R/W		w1_input	BV:1017	0 TO 1	W1
Thermostat W2 Input	R/W		w2_input	BV:1018	0 TO 1	W2
Thermostat Y1 Input	R/W		y1_input	BV:1019	0 TO 1	Y1
Thermostat Y2 Input	R/W		y2_input	BV:1020	0 TO 1	Y2
TIME range alert	R/W		a_notime	BV:237	0 TO 1	
Today Is A Holiday	READ ONLY		holtoday	BV:98	0 TO 1	HOLTODAY
Tomorrow Is A Holiday	READ ONLY		hol_tmrw	BV:96	0 TO 1	HOL_TMRW
Transducer Sensor Alerts	R/W		trans_al	BV:310	0 TO 1	TRANS_AL
Tstat Adaptive Staging	R/W		adptstat	BV:115	0 TO 1	ADPTSTAT
TSTAT Cool alert	R/W		a_impcl	BV:220	0 TO 1	
TSTAT Heat alert	R/W		a_impht	BV:221	0 TO 1	
TSTAT Heat Cool alert	R/W		a_simhc	BV:223	0 TO 1	
Unocc Free Cool Active	READ ONLY		ufc_act	BV:135	0 TO 1	UFC_ACT
USB Find Restore File	R/W		backfile	BV:111	0 TO 1	BACKFILE
User Password Protection	R/W		pass_ebl	BV:100	0 TO 1	PASS_EBL

## APPENDIX E — BACNET POINTS LIST

### MULTI-STATE VALUES (MSV) POINTS

POINT DESCRIPTION	POINT ACCESS	UNITS	BACnet OBJECT NAME	BACnet ID	VALUE RANGE	CCN POINT EQUIVALENT
Active Occupancy control	READ ONLY		occ_ctrl	MSV:14	0 TO 6	OCC_CTRL
Active Type of Heat	READ ONLY	enum	htsrctyp	MSV:2004	0 TO 6	HTSRCTYP
Alert from thermostat	READ ONLY		tstat_alert	MSV:8	0 TO 65535	THM_ALT
Analog Input IAQ Control	R/W		iaqancfg	MSV:25	0 TO 3	IAQANCFG
Backup and Restore	READ ONLY		bac_rest	MSV:44	0 TO 2	
BACnet BMS baud rate	READ ONLY		bac_baud	MSV:18	0 TO 5	BAC_BAUD
BAS Protocol Select	R/W		bms_cfg	MSV:11	0 TO 2	BMS_CFG
BMS Occupancy Request	R/W		bms_occ	MSV:12	0 TO 2	BMS_OCC
Communications status	R/W		e0commst	MSV:17	0 TO 1	E0COMMST
Comp. Framework	R/W		sysvtype	MSV:2003	0 TO 2	SYSVTYPE
Cool demand Limit Level	R/W		cdlm_level	MSV:56	0 TO 3	CDMDLLEV
Fan Based Dehum Type	R/W		fbd_type	MSV:58	0 TO 2	FBD_TYPE
Fan Status SW Type	R/W		fanstcfg	MSV:451	0 TO 2	FANSTCFG
Filter Status Sw Channel	R/W		filter_channel	MSV:41	0 TO 5	FILTCHAN
Filter Status Swith Type	R/W		filt_cfg	MSV:42	0 TO 2	FILT_CFG
Firmware Release State	READ ONLY		fw_state	MSV:19	0 TO 2	FW_STATE
Heat demand Limit Level	R/W		hdlim_level	MSV:57	0 TO 3	HDMDLLEV
IAQ override sw channel	R/W		iaqo_sw_chan	MSV:444	0 TO 5	IAQOCHAN
Keep configuration	R/W		keepconf	MSV:47	0 TO 2	KEEPCONF
Linkage Occupied Request	R/W		lnk_occ	MSV:13	0 TO 2	LNK_OCC
ODF State	R/W		odfstate	MSV:452	0 TO 3	ODFSTATE
Operation Status Color	READ ONLY		color	MSV:9	0 TO 15	COLOR
Remote Occupancy Channel	R/W		rmocchan	MSV:46	0 TO 5	RMOCCCHAN
Remote Occupancy Sw Type	R/W		rmoc_cfg	MSV:45	0 TO 1	RMOCC_CFG
Running Mode Operation	READ ONLY		sub_mode	MSV:43	0 TO 2	SUB_MODE
System Demand	READ ONLY		sys_demand_enum	MSV:101	0 TO 255	SYS_DMDE
System Mode	READ ONLY		sys_mode	MSV:2002	0 TO 2	SYSMODE
Test Inactivity Time Out	R/W		test_ito	MSV:156	0 TO 2	TEST_ITO
Thermostat Hardware Type	R/W		tstat_type	MSV:5	0 TO 3	STATTYPE
Type of Heat Installed	R/W		ht_type	MSV:16	0 TO 2	HEATTYPE
Unit Control Type	R/W		control_type	MSV:2	0 TO 2	CTRLTYPE
Ventilation Method	R/W		venttype	MSV:453	0 TO 4	VENTTYPE
Ventilation Status	READ ONLY		ventstat	MSV:6	0 TO 9	VENTSTAT
When to Unocc Free Cool?	R/W		ufc_cfg	MSV:24	0 TO 2	UFC_CFG

### STRING VALUES (SV) POINTS

POINT DESCRIPTION	POINT ACCESS	UNITS	BACnet OBJECT NAME	BACnet ID	VALUE RANGE	CCN POINT EQUIVALENT
Application SW Version	READ ONLY		fw_cesr	String	a to z, A to Z, 0 to 9 and -	FW_CESR
BACnet Firmware Version	R/W		bac_fwv	String	a to z, A to Z, 0 to 9 and -	BAC_FWV
Base Board serial number	READ ONLY		bd_ser	String	a to z, A to Z, 0 to 9 and -	BD_SER
Bootloader SW Version	READ ONLY		bl_cesr	String	a to z, A to Z, 0 to 9 and -	BL_CESR
Device Description	READ ONLY		dev_desc	String	a to z, A to Z, 0 to 9 and -	DEV_DESC
Device Location	READ ONLY		dev_loc	String	a to z, A to Z, 0 to 9 and -	DEV_LOC
Equipment Model number	READ ONLY		eq_mod	String	a to z, A to Z, 0 to 9 and -	EQ_MOD
Equipment Serial number	READ ONLY		eq_ser	String	a to z, A to Z, 0 to 9 and -	EQ_SER
MBB Part Number	READ ONLY		bd_cepl	String	a to z, A to Z, 0 to 9 and -	BD_CEPL
MBB Program Part Number	READ ONLY		bd_cepp	String	a to z, A to Z, 0 to 9 and -	BD_CEPP
ProgramLocationProperty	R/W		progloc	String	a to z, A to Z, 0 to 9 and -	PROGLOC
ProgramObject Name	R/W		progname	String	a to z, A to Z, 0 to 9 and -	PROGNAME
Reference Number	READ ONLY		ref_num	String	a to z, A to Z, 0 to 9 and -	REF_NUM
Ventilation Status	READ ONLY		venttext	String	a to z, A to Z, 0 to 9 and -	VENTTEXT

## CONTROL SET POINT AND CONFIGURATION LOG

MODEL NO: \_\_\_\_\_  
 SERIAL NO: \_\_\_\_\_  
 DATE: \_\_\_\_\_  
 TECHNICIAN: \_\_\_\_\_

SOFTWARE VERSION: \_\_\_\_\_  
 MBB: CESR131690-\_\_\_\_\_

### INDICATE UNIT SETTINGS BELOW

CONTROL TYPE: Thermostat/T-55 Space Temp./T-56 Space Temp./T-59 Space Temp.  
 SETPOINT: Cooling Occupied: \_\_\_\_\_ Unoccupied: \_\_\_\_\_  
 Heating Occupied: \_\_\_\_\_ Unoccupied: \_\_\_\_\_

### SETTINGS - MAIN MENU LAYOUT

DISPLAY TEXT	EXPANDED DISPLAY TEXT	VALUES	UNITS	DEFAULT	POINT	ENTRY
<b>SETTINGS</b>	Settings Menu					
<b>SPACE SET POINTS</b>	Space Setpoints Adjustment Menu					
<b>OCC COOL SETPOINT</b>	Occupied Cool Setpoint	55 to 80	°F	78	OCSP	
<b>OCC HEAT SETPOINT</b>	Occupied Heat Setpoint	55 to 80	°F	68	OHSP	
<b>UNOCC COOL SETPNT</b>	Unoccupied Cool Setpoint	65 to 95	°F	85	UCSP	
<b>UNOCC HEAT SETPNT</b>	Unoccupied Heat Setpoint	40 to 80	°F	60	UHSP	
<b>HEAT-COOL SP GAP</b>	Heat-Cool Setpoint Gap	2 to 10	°F	5	HCSP_GAP	
<b>SPT SLIDER RANGE</b>	SPT Offset Range (+/-)	0 to 5	°F	5	SPTO_RNG	
<b>OCC SPRH SETPOINT</b>	Occupied SPRH Setpoint	0 to 100	%	50	SPRH_OSP	
<b>UNOCC SPRH SET PT</b>	Unoccupied SPRH Setpoint	0 to 100	%	80	SPRH_USP	
<b>SPRH RH DEADBAND</b>	Space RH Deadband	2 to 20	%	8	SPRH_DB	
<b>SA TEMPERING SP</b>	SA tempering Set point	30 to 80	°F	55	SATEMPSP	
<b>TEMP DEMAND CONFIG</b>	Temperature Demand Configuration menu					
<b>LOW COOL DMD ON</b>	Low Cool Demand On	-1 to 2	°F	0.5	DMDLCON	
<b>HIGH COOL DMD ON</b>	High Cool Demand On	0.5 to 20	°F	1.5	DMDHCON	
<b>LOW COOL DMD OFF</b>	Low Cool Demand Off	-1 to 2	°F	-0.5	DMDLCOFF	
<b>COOL DMD LEVEL UP</b>	Cool Demand Level Up	-2 to 2	°F	-0.2	CDMD_LUP	
<b>LOW HEAT DMD ON</b>	Low Heat Demand On	-1 to 2	°F	0.5	DMDLHON	
<b>HIGH HEAT DMD ON</b>	High Heat Demand On	0.5 to 20	°F	2	DMDLHON	
<b>LOW HEAT DMD OFF</b>	Low Heat Demand Off	-1 to 2	°F	-0.5	DMDLHOFF	
<b>HEAT DMD LEVEL UP</b>	Heat Demand Level Up	-2 to 2	°F	-0.2	HDMD_LUP	
<b>DEMAND TIMEGUARD1</b>	Space Demand Time Guard1	60 to 600	sec	120	TDMD_TG1	
<b>DEMAND TIMEGUARD2</b>	Space Demand Time Guard2	0 to 600	sec	240	TDMD_TG2	
<b>DEMAND TIMEGUARD3</b>	Space Demand Time Guard3	5 to 120	min	10	TDMD_TG3	
<b>DMD LIMIT CONFIG</b>	DEMAND LIMIT CONFIG					
<b>COOL DMD LIM LEV1</b>	COOL DMD Offset level 1	0 to 99	°F	1	CLDOLEV1	
<b>COOL DMD LIM LEV2</b>	COOL DMD Offset level 2	0 to 99	°F	3	CLDOLEV2	
<b>COOL DMD LIM LEV3</b>	COOL DMD Offset level 3	0 to 99	°F	5	CLDOLEV3	
<b>HEAT DMD LIM LEV1</b>	Heat DMD Offset level 1	0 to 99	°F	1	HTDOLEV1	
<b>HEAT DMD LIM LEV2</b>	Heat DMD Offset level 2	0 to 99	°F	3	HTDOLEV2	
<b>HEAT DMD LIM LEV3</b>	Heat DMD Offset level 3	0 to 99	°F	5	HTDOLEV3	
<b>CLOCK</b>	CLOCK ADJUSTMENT MENU					
<b>TIME</b>	Clock Hour and Minute	xx:xx	hh.mm		TIME	
<b>DATE</b>	Current Date	MM/DD/YYYY			DATE	
<b>DAYLIGHT SAVINGS</b>	Daylight Savings Configuration Menu					
<b>DAYLIGHT SAVINGS?</b>	DST allowed?	Enable/Disable		1	DST_CFG	

## SETTINGS - MAIN MENU LAYOUT (CONT)

DISPLAY TEXT	EXPANDED DISPLAY TEXT	VALUES	UNITS	DEFAULT	POINT	ENTRY
<b>CLOCK (cont)</b>	CLOCK ADJUSTMENT MENU					
<b>DST START MONTH</b>	DST Start Month	1=JANUARY, 2=FEBRUARY, 3=MARCH, 4=APRIL, 5=MAY, 6=JUNE, 7=JULY, 8=AUGUST, 9=SEPTEMBER, 10=OCTOBER, 11=NOVEMBER, 12=DECEMBER		3	STARTM	
<b>DST START WEEK</b>	DST Start Week	1 to 5		2	STARTW	
<b>DST START DAY</b>	DST Start Day	1=MONDAY, 2=TUESDAY, 3=WEDNESDAY, 4=THURSDAY, 5=FRIDAY, 6=SATURDAY, 7=SUNDAY		7	STARTD	
<b>DST MINS TO ADD</b>	DST Minutes to Add	0 to 90	min	60	MINADD	
<b>DST STOP MONTH</b>	DST Stop Month	1=JANUARY, 2=FEBRUARY, 3=MARCH, 4=APRIL, 5=MAY, 6=JUNE, 7=JULY, 8=AUGUST, 9=SEPTEMBER, 10=OCTOBER, 11=NOVEMBER, 12=DECEMBER		11	STOPM	
<b>DST STOP WEEK</b>	DST Stop Week	1 to 5		1	STOPW	
<b>DST STOP DAY</b>	DST Stop Day	1=MONDAY, 2=TUESDAY, 3=WEDNESDAY, 4=THURSDAY, 5=FRIDAY, 6=SATURDAY, 7=SUNDAY		7	STOPD	
<b>DST MINS TO SUB</b>	DST Minutes to Subtract	0 to 90	min	60	MINSUB	
<b>START TIME IN DAY</b>	Time in day to start DST	0 to 600	min	120	DST_TOD	
<b>SCHEDULES</b>	SCHEDULES ADJUSTMENT MENU					
<b>SCHEDULE NUMBER</b>	CCN Schedule Number	0 = Always Occupied, 1-64 = Local Schedule, 65-99 = Global Schedule		0 = Always Occupied	SCHEDNUM	
<b>OCCUPANCY SCHEDULE</b>	OCCUPANCY SCHEDULE DATA					
<b>Holiday adjustment Menu</b>	Holiday adjustment Menu					
<b>ALLOW G. HOLIDAY?</b>	Accept Global Holidays?	Yes/No		No	HOLIDAYT	
<b>TIMED OVR LENGTH</b>	Timed Override Duration	0 to 4	hrs	4	OTL_CFG	
<b>CAN CANCEL T.OVR</b>	Allow SPT Ovrld Cancel	Yes/No		No	CLROVCFG	
<b>UNIT CONFIGURATIONS</b>	UNIT CONFIGURATIONS MENU					
<b>GENERAL</b>	General Unit Configurations Menu					
<b>STARTUP DELAY</b>	Unit Startup Delay	10 to 600	sec	30	STARTDLY	
<b>UNIT CONTROL TYPE</b>	Unit Control Type	0=TSTAT, 1=SPACE SEN, 2=RAT SEN		0=TSTAT	CTRLTYPE	
<b>THERMOSTAT TYPE</b>	Thermostat Hardware Type	0=CONV 2C2H, 1=DIGI 2C2H, 2=CONV 3C2H, 3=DIGI 3C2H		0=CONV 2C2H	STATTYPE	
<b>VENT METHOD</b>	Ventilation Method	0=NONE, 1=ECON, 2=2POS DMPR, 3=ERV, 4=ECON ERV		0: No FIOP 1: Economizer FIOP 2: Two Position Damper FIOP	VENTTYPE	

## SETTINGS - MAIN MENU LAYOUT (CONT)

DISPLAY TEXT	EXPANDED DISPLAY TEXT	VALUES	UNITS	DEFAULT	POINT	ENTRY
<b>UNIT CONFIGURATIONS (cont)</b>	UNIT CONFIGURATIONS MENU					
<b>2POS/ERV CHANNEL</b>	2-Pos Damper/ERV Channel	0=NONE, 1=MBB RLY11, 2=MBB RLY06,		0: No FIOP 2: FIOP	EV2PCHAN	
<b>ADAPTIVE TSTAT</b>	Tstat Adaptive Staging	Yes/No		Yes	ADPTSTAT	
<b>DIRTY FILTER TIME</b>	Change Filter Timer	0 to 9999	hrs	0	FILTLIFE	
<b>TEST MODE TIMEOUT</b>	Test inactivity time out	0=Disabled, 1=30 minutes, 2=1 hour, 3=2 hours, 4=4 hours, 5=8 hours, 6=12 hours		4	TEST_ITO	
<b>CCH MAX TEMP</b>	CCH Max Temperature	40 to 90	°F	65	CCHMAXT	
<b>STD BARO PRESSURE</b>	Std Barometric Pressure	13 to 35	Hg	29.92	STD_BARP	
<b>LINK STAGEUP TIME</b>	Linkage Stage inc. time	60 to 600	sec	180	LSTAGINC	
<b>UNIT'S MAX SAT</b>	Unit's Maximum SAT	130 to 210	°F	200	UMAX_SAT	
<b>UNIT'S MIN SAT</b>	Unit's Minimum SAT	30 to 70	°F	32	UMIN_SAT	
<b>AUTO SAT FAULTS?</b>	Auto Clr SAT Limit Fault	Yes/No		Yes	SATLACLR	
<b>SA FREEZE PROTECT</b>	SAT Freeze Protection	Enable/Disable		Enable	SATFZPRO	
<b>ADAPTIVE TCS?</b>	Adaptive Temp Comp Start	Enable/Disable		Enable	TCS_CFG	
<b>USER TCS BIASTIME</b>	User TCS Start Bias Time	0 to 180	min	0	TCSUBIAS	
<b>SWITCH INPUTS CONFIGS</b>	DI Config Menu					
<b>FIRE SW CHANNEL</b>	Fire Switch Channel	0=None, 1=MBB D112, 2=MBB D113, 3=MBB D114, 4=MBB D102, 5=MBB D103, 6=MBB Y3		0: No FIOP 5: FIOP	FIRECHAN	
<b>FIRE SHUTDOWN SW</b>	Fire Shutdown Sw Type	0=NORM OPEN, 1=NORM CLSD		0=NORM OPEN	FIRE_CFG	
<b>HUMSTAT CHANNEL</b>	Humidistat Status Chan.	0=None, 1=MBB D112, 2=MBB D113, 3=MBB D114, 4=MBB D102, 5=MBB D103, 6=MBB Y3		0=None	HUMD-CHAN	
<b>HUMSTAT SW TYPE</b>	Humidistat Switch Type	0=NORM OPEN, 1=NORM CLSD,		0=NORM OPEN	HUMD_CFG	
<b>FILTER SW CHANNEL</b>	Filter Status Sw Channel	0=None, 1=MBB D112, 2=MBB D113, 3=MBB D114, 4=MBB D102, 5=MBB D103, 6=MBB Y3		0: No FIOP 1: FIOP	FILTCHAN	
<b>FILTER SW TYPE</b>	Filter Status Swith Type	0=NORM OPEN, 1=NORM CLSD		0=NORM OPEN	FILT_CFG	
<b>REMOTE OCC CHAN</b>	Remote Occupancy Channel	0=None, 1=MBB D112, 2=MBB D113, 3=MBB D114, 4=MBB D102, 5=MBB D103, 6=MBB Y3		0=None	RMOC-CHAN	
<b>REMOTE OCC TYPE</b>	Remote Occupancy Sw Type	0=NORM OPEN, 1=NORM CLSD		0=NORM OPEN	RMOC_CFG	
<b>REM.SHUTDOWN CHAN</b>	Remote Shutdown Channel	0=None, 1=MBB D112, 2=MBB D113, 3=MBB D114, 4=MBB D102, 5=MBB D103, 6=MBB Y3		0=None	ROFFCHAN	
<b>REM.SHUTDOWN SW T</b>	Remote Shutdown SW Type	0=NORM OPEN, 1=NORM CLSD		0=NORM OPEN	ROFF_CFG	
<b>REM.SHUTDOWN TYPE</b>	Remote Shutdown ALM Type	0=Normal, 1=Emergency		0=Normal	ROFFTYPE	

## SETTINGS - MAIN MENU LAYOUT (CONT)

DISPLAY TEXT	EXPANDED DISPLAY TEXT	VALUES	UNITS	DEFAULT	POINT	ENTRY
<b>SWITCH INPUTS CONFIGS (cont)</b>	DI Config Menu					
<b>COFS CHANNEL</b>	COFS Assigned Channel	0=None, 1=MBB DI12, 2=MBB DI13, 3=MBB DI14, 4=MBB DI02, 5=MBB DI03, 6=MBB Y3		0: No FIOP 4: FIOP	COFSCHAN	
<b>COFS TYPE</b>	COFS Switch Type	0=NORM OPEN, 1=NORM CLSD		1=NORM CLSD	COFS_CFG	
<b>GEN STATUS CHAN</b>	General Status Channel	0=None, 1=MBB DI12, 2=MBB DI13, 3=MBB DI14, 4=MBB DI02, 5=MBB DI03, 6=MBB Y3		0=None	GEN_CHAN	
<b>GEN STAT SW TYPE</b>	General Status Sw Type	0=NORM OPEN, 1=NORM CLSD		0=NORM OPEN	GENS_CFG	
<b>SHUTDOWN GEN STAT</b>	General Status shutdown?	Yes/No		Yes	GENFATAL	
<b>ENTHALPY SW CHAN</b>	Enthalpy Sw Channel	0=None, 1=MBB DI12, 2=MBB DI13, 3=MBB DI14, 4=MBB DI02, 5=MBB DI03, 6=MBB Y3		0=NONE	ENTHCHAN	
<b>ENTHALPY SW TYPE</b>	Enthalpy Switch Type	0=NORM OPEN, 1=NORM CLSD		0=NORM OPEN	ENTH_CFG	
<b>FAN STAT CHANNEL</b>	Fan Status Channel	0=None, 1=MBB DI12, 2=MBB DI13, 3=MBB DI14, 4=MBB DI02, 5=MBB DI03, 6=MBB Y3		0=NONE	FNSTCHAN	
<b>FAN STAT SW CFG</b>	Fan Status SW Type	0=NORM OPEN, 1=NORM CLSD		0=NORM OPEN	FANSTICFG	
<b>IAQ OVERRIDE SW CH</b>	IAQ override sw channel	0=None, 1=MBB DI12, 2=MBB DI13, 3=MBB DI14, 4=MBB DI02, 5=MBB DI03, 6=MBB Y3		0=NONE	IAQOCHAN	
<b>IAQ OVRRD SW TYPE</b>	IAQ Override Switch Type	0=NORM OPEN, 1=NORM CLSD		0=NORM OPEN	IAQOSCFG	
<b>PHASE MON CHANNEL</b>	Phase Monitor Channel	0=None, 1=MBB DI12, 2=MBB DI13, 3=MBB DI14, 4=MBB DI02, 5=MBB DI03, 6=MBB Y3		0: No FIOP 3: FIOP	PMR_CHAN	
<b>PHASE MON SW TYPE</b>	Phase Monitor SW Type	0=NORM OPEN, 1=NORM CLSD		1=NORM CLSD	PMR_CFG	
<b>SMOKE PURGE CHAN</b>	Smoke Purge Sw Channel	0=None, 1=MBB DI12, 2=MBB DI13, 3=MBB DI14, 4=MBB DI02, 5=MBB DI03, 6=MBB Y3		0=NONE	PURGCHAN	
<b>SMOKE PURGE TYPE</b>	Smoke Purge Switch Type	0=NORM OPEN, 1=NORM CLSD		0=NORM OPEN, 1=NORM CLSD	PURG_CFG	
<b>SMOKE PRESS CHAN</b>	Smoke Pressure Sw Chan	0=None, 1=MBB DI12, 2=MBB DI13, 3=MBB DI14, 4=MBB DI02, 5=MBB DI03, 6=MBB Y3		0=NONE	PRESCHAN	
<b>SMOKE PRESS TYPE</b>	Smoke Pressure Sw Type	0=NORM OPEN, 1=NORM CLSD		0=NORM OPEN	PRES_CFG	

## SETTINGS - MAIN MENU LAYOUT (CONT)

DISPLAY TEXT	EXPANDED DISPLAY TEXT	VALUES	UNITS	DEFAULT	POINT	ENTRY
<b>SWITCH INPUTS CONFIGS (cont)</b>	DI Config Menu					
<b>SMOKE EVAC CHAN</b>	Smoke Evacuation Sw Chan	0=None, 1=MBB DI12, 2=MBB DI13, 3=MBB DI14, 4=MBB DI02, 5=MBB DI03, 6=MBB Y3		0=NONE	EVACCHAN	
<b>SMOKE EVAC TYPE</b>	Smoke Evacuation Sw Type	0=NORM OPEN, 1=NORM CLSD		0=NORM OPEN	EVAC_CFG	
<b>ANALOG INPUT CONFIGS</b>	Analog Inputs Configuration Menu					
<b>SPRH SENS CHANNEL</b>	SPRH Assigned Channel	0=None, 1=MBB AI06, 2=MBB AI07, 3=MBB AI08		0=NONE	SPRHCHAN	
<b>SPRH RH @ 4MA</b>	SPRH Sensor Value at 4mA	0 to 100	%	0	SPRH_4MA	
<b>SPRH RH @ 20MA</b>	SPRH Sensor Value @ 20mA	0 to 100	%	100	SPRH20MA	
<b>IAQ SENSOR CHAN</b>	IAQ Assigned Channel	0=None, 1=MBB AI06, 2=MBB AI07, 3=MBB AI08		0: No FIOP 2:FIOP	IAQ_CHAN	
<b>IAQ PPM @ 4MA</b>	IAQ Sensor Value at 4mA	0 to 5000	PPM	0	IAQ_4MA	
<b>IAQ PPM @ 20MA</b>	IAQ Sensor Value at 20mA	0 to 5000	PPM	2000	IAQ_20MA	
<b>OAQ SENSOR CHAN</b>	OAQ Assigned Channel	0=None, 1=MBB AI06, 2=MBB AI07, 3=MBB AI08		0=NONE	OAQ_CHAN	
<b>OAQ PPM @ 4MA</b>	OAQ Sensor Value at 4mA	0 to 5000	PPM	0	OAQ_4MA	
<b>OAQ PPM @ 20MA</b>	OAQ Sensor Value at 20mA	0 to 5000	PPM	2000	OAQ_20MA	
<b>OARH SENSOR CHAN</b>	OARH Assigned Channel	0=None, 1=MBB AI06, 2=MBB AI07, 3=MBB AI08		0: No FIOP 3: FIOP	OARHCHAN	
<b>OARH RH @ 4MA</b>	OARH Sensor Value at 4mA	0 to 100	%	0	OARH_4MA	
<b>OARH RH @ 20MA</b>	OARH Sensor Val. at 20mA	0 to 100	%	100	OARH20MA	
<b>RARH SENS CHANNEL</b>	RARH Assigned Channel	0=None, 1=MBB AI06, 2=MBB AI07, 3=MBB AI08		0=NONE	RARHCHAN	
<b>RARH RH @ 4MA</b>	RARH Sensor Value at 4mA	0 to 100	%	0	RARH_4MA	
<b>RARH RH @ 20MA</b>	RARH Sensor Value @ 20mA	0 to 100	%	100	RARH20MA	
<b>OACFM SENSOR CHAN</b>	OACFM Assigned Channel	0=None, 1=MBB AI06, 2=MBB AI07, 3=MBB AI08		0=NONE	OACFM-CHAN	
<b>OACFM @ 4MA</b>	OACFM value at 4MA	0 to 2000	CFM	0	OACFM_4MA	
<b>OACFM @ 20MA</b>	OACFM Value @ 20mA	2000 to 5000	CFM	2000	OACFM20MA	
<b>COOLING</b>	Cooling Configurations Menu					
<b>COOL STAGEUP TIME</b>	Cool Stage Increase Time	120 to 999	sec	450	CSTAGINC	
<b>COOL SATTREND LEV</b>	Cooling SAT Trend Level	-1 to 1		-0.2	SAT_TLC	
<b>UPPER MIN SAT</b>	Cool Min SAT Upper Level	35.0 to 65.0	°F	56	SATMIN_H	
<b>LOWER MIN SAT</b>	Cool Min SAT Lower Level	35.0 to 65.0	°F	46	SATMIN_L	
<b>COOL FANOFF DELAY</b>	Cooling Fan-Off Delay	0 to 600	sec	60	COOL_FOD	
<b>ODF HIGH SPD TIME</b>	ODF High Speed Time	0 to 300	sec	120	MINODFTM	
<b>FAN BASED DEHUM</b>	Fan Based Dehum CFG Menu					
<b>FBD CONTROL TYPE</b>	Fan Based Dehum Type	0=NONE, 1=Comfort, 2=Max		0=NONE	FBD_TYPE	
<b>FBD COOL DELTA</b>	FBDH Low Set Point	-20 to 0	ΔF	-2.5	FBDLO_SP	
<b>FBD MAX SST SP</b>	FBDH Max Mode SST SP	20 to 60	°F	38	FBDSSSTSP	
<b>FBD SST MIN VALUE</b>	FBDH Min SST Threshold	10 to 60	°F	32	FBDH_SST	
<b>FBD CMFT SAT SP</b>	FBDH Comfort SAT SP	35 to 80	°F	46	FBDH_SAT	
<b>FBD CMFT SAT DT</b>	FBD Comfort SAT Delta	0 to 30	°F	11	FBDSATDT	



## SETTINGS - MAIN MENU LAYOUT (CONT)

DISPLAY TEXT	EXPANDED DISPLAY TEXT	VALUES	UNITS	DEFAULT	POINT	ENTRY
<b>COOLING (cont)</b>	Cooling Configurations Menu					
<b>FBD MIN FAN SPD</b>	FBDH Min Fan Speed	0 to 3000	RPM	same as IDF LOW COOL SPD (see Page 64)	FDRPMMIN	
<b>FBD MAX FAN SPD</b>	FBDH Max Fan Speed	0 to 3000	RPM	same as IDF HIGH COOL SPD (See page 64)	FDRPMMAX	
<b>LOW AMBIENT</b>	LOW AMBIENT CONFIGS MENU					
<b>NO LOW CHARGE OAT</b>	Low Charge Disable Temp	-40 to 50	°F	10	LOCH_LOT	
<b>LOW COOL MIN OAT</b>	Low Cool lockout Temp	-20 to 60	°F	10	LCLOCKSP	
<b>HEATING</b>	Heating Configurations Menu					
<b>TIME BTWN DEFROST</b>	Min Time BTWN Defrosts	30 to 120	min	60	MINDFINT	
<b>MAX DEFROST TIME</b>	Defrost Max Duration	5 to 25	min	10	MAXDFTMR	
<b>HEAT STAGEUP TIME</b>	Heat Stage Increase Time	120 to 999	sec	450	HSTAGINC	
<b>HEAT SATTREND LEV</b>	Heating SAT Trend Level	-1 to 1		0.2	SAT_TLH	
<b>LOWER MAX SAT</b>	Heat Max SAT Lower Level	85 to 200	°F	140	SATMAX_L	
<b>UPPER MAX SAT</b>	Heat Max SAT Upper Level	85 to 200	°F	170	SATMAX_H	
<b>HEAT FANOFF DELAY</b>	Heating Fan-Off Delay	10 to 600	sec	60	HEAT_FOD	
<b>HEAT LOCKOUT OAT</b>	Heating Lockout Temp	40 to 125	°F	75	OATLHEAT	
<b>MEC HEATLOCK TEMP</b>	Mech Heat Lockout Temp	-30 to 40	°F	-8	OATLMECH	
<b>LLSV ON TIME</b>	LiquidLine Valve On Time	0 to 300	sec	60	LLSV_CT	
<b>SAT DURING HEAT?</b>	SAT heat mode sensing	Enable/Disable		Enable	SAT_HEAT	
<b>SA TEMPER ENABLED</b>	Supply Air Temper Enable	Yes/No		No	SATEMPEN	
<b>SA TEMPERING SP</b>	SA tempering Set point	35 to 80	°F	55	SATEMPSP	
<b>TEMPER MAX OAT</b>	Max OAT for SA tempering	40 to 80	°F	65	OATSTEMP	
<b>START DEFROST DLY</b>	Startup Defrost Delay	0 to 120	min	5	DFHLD_T	
<b>ELECTRIC HEAT</b>	Electric Heat Setting Menu					
<b>HEATING STAGE QTY</b>	Number Of Heating Stages	0 to 3		1	NUMHSTGS	
<b>MAX OAT FOR 3STGS</b>	Max OAT for 3 Heat Stags	0 to 90	°F	20	HT2LCTMP	
<b>HEAT MIN ON</b>	Heat Minimum On Time	60 to 600	sec	120	H_MINON	
<b>HEAT MIN OFF</b>	Heat Minimum Off Time	60 to 600	sec	120	H_MINOFF	
<b>PREHEAT W/O IDF?</b>	Pre-Heat HX without IDF?	Enable/Disable		Disable	PREHT_HX	
<b>PREHEAT FAN DELAY</b>	Pre-Heat Fan On Delay	0 to 120	sec	30	PREHT_TM	
<b>COMPRESSOR DIAG</b>	COMPRESSOR DIAGNOSTIC MENU					
<b>COMP MIN ON TIME</b>	Compressor Min On Time	180 to 600	sec	300	C_MINON	
<b>COMP MIN OFF TIME</b>	Compressor Min Off Time	120 to 600	sec	180	C_MINOFF	
<b>STRIKE CLEAR TIME</b>	Runtime to Reset Strikes	120 to 999	sec	300	MIN_ON_S	
<b>CHARGE DIAGNOSTICS</b>	Refrigerant Charge Diagnostic Config Menu					
<b>LOW CHARGE LEVEL</b>	Low Refrig Charge Level	0 to 150	PSI	50	LOCHARGE	
<b>NO LOW CHARGE OAT</b>	Low Charge Disable Temp	-40 to 50	°F	10	LOCH_LOT	
<b>CIR.A SDP LIMIT</b>	CirA High Pressure Limit	400 to 700	PSI	670	HIPLIM_A	
<b>LOW DISCHARGE LEV</b>	Low Discharge Level	0 to 20	°F	0	SDTLEV	
<b>LOW DISCHRG DIAG</b>	Low Discharge Diagnostic	Enable/Disable		Disable	DISLDPAL	
<b>MIN PRESS RATIO</b>	Minimum Pressure Ratio	0 to 5		1.35	MINPSI_R	
<b>LOW SUCTION DIAG.</b>	Low Suction Diagnostic Config Menu					
<b>LOW SUC OK TEMP</b>	Suction OK Temperature	10 to 50	°F	18	SSTOK	
<b>LOW SUC LEVEL 1</b>	Low Suction Level 1 Temp	10 to 50	°F	20	SSTLEV1	
<b>LOW SUC LEVEL 2</b>	Low Suction Level 2 Temp	5 to 50	°F	15	SSTLEV2	
<b>LOW SUC LEVEL 3</b>	Low Suction Level 3 Temp	0 to 50	°F	10	SSTLEV3	
<b>LO SUC DIAG DELAY</b>	Delay On Low SST Check	0 to 300	sec	0	SSTCKDLY	
<b>HEAT LO SUC OFFST</b>	Heat Low Suc Lvl Offset	0 to 100	°F	30	SSTOFSET	
<b>COMPRESSOR TRANSITION</b>	Compressor Transition diagnostic config menu					
<b>COMP L2 DIAG DLY</b>	Comp Level 2 Diag Delay	1 to 300	sec	15	CDDTLEV2	
<b>DIAG. COMP OFF</b>	Diag Comp Unexpected Off	Enable/Disable		Enable	CD_UEOFF	
<b>CIR STUCK ON DIAG</b>	Circuit Stuck On Diag.	Enable/Disable		Enable	DCKTOFF	
<b>CIR.A MIN DIS.P</b>	Min discharge change	0 to 99	PSI	8	MDP_DISA	
<b>CIR.A MIN SUC.P</b>	Min Suction change	0 to 99	PSI	10	MDP_SUCA	
<b>OFF P.RATIO</b>	CirA P.Ratio off change	-1 to 1		-0.3	OFFPR_A	
<b>DEFROST UEOFF DLY</b>	Comp UEOFF Diag Delay	0 to 300	sec	30	ACAOFF_T	

## SETTINGS - MAIN MENU LAYOUT (CONT)

DISPLAY TEXT	EXPANDED DISPLAY TEXT	VALUES	UNITS	DEFAULT	POINT	ENTRY
<b>INDOOR FAN</b>	Indoor Fan Configurations Menu					
<b>OCCUPIED FAN?</b>	Fan On When Occupied	Yes/No		Yes	FANON_OC	
<b>IDF MAX SPEED</b>	IDF Maximum Fan Speed	0 to 100	%	100	SPEEDMAX	
<b>IDF VENT SPD</b>	IDF Vent Speed-RPM	0 to 3000	RPM	same as IDF LOW COOL SPD (see Page 64)	RPM_VENT	
<b>IDF HEAT SPD</b>	IDF Heat Speed-RPM	0 to 3000	RPM	same as IDF HIGH COOL SPD (See page 64)	RPM_HEAT	
<b>IDF LOW COOL SPD</b>	IDF Low Cool Speed-RPM	0 to 3000	RPM	1106: Size 04 Standard Static Fan 1281: Size 04 Medium Static Fan 1457: Size 04 High Static Fan 1112: Size 05 Standard Static Fan 1269: Size 05 Medium Static Fan 1439: Size 05 High Static Fan 230v 1 ph 1556: Size 05 High Static Fan 230v 3ph, 460v, 575v 1258: Size 06 Standard Static Fan 1398: Size 06 Medium Static Fan 1556: Size 06 High Static Fan 230v 1 ph 1659: Size 06 High Static Fan 230v 3ph, 460v, 575v 1184: Size 07 Standard Static Fan 1302: Size 07 Medium Static Fan 1460: Size 07 High Static Fan	RPM_LCL	
<b>IDF HIGH COOL SPD</b>	IDF High Cool Speed-RPM	0 to 3000	RPM	1474: Size 04 Standard Static Fan 1708: Size 04 Medium Static Fan 1942: Size 04 High Static Fan 1482: Size 05 Standard Static Fan 1693: Size 05 Medium Static Fan 1919: Size 05 High Static Fan 230v 1 ph 2075: Size 05 High Static Fan 230v 3ph, 460v, 575v 1677: Size 06 Standard Static Fan 1864: Size 06 Medium Static Fan 2075: Size 06 High Static Fan 230v 1 ph 2212: Size 06 High Static Fan 230v 3ph, 460v, 575v 1794: Size 07 Standard Static Fan 1973: Size 07 Medium Static Fan 2212: Size 07 High Static Fan	RPM_HCL	
<b>IDF FREE COOL SPD</b>	IDF Free Cool Speed-RPM	0 to 3000	RPM	same as IDF LOW COOL SPD (see Page 64)	RPM_FCL	
<b>FAULT ON ERROR</b>	Shut Down on IDF Failure	Yes/No		Yes	FATALFAN	
<b>ECONOMIZER</b>	Economizer Configurations Menu					
<b>VENT METHOD</b>	Ventilation Method	0=NONE, 1=ECON, 2=2POS DMPR, 3=ERV, 4=ECON ERV		0: No FIOP 1: Economizer FIOP 2: Two Position Damper FIOP	VENTTYPE	

## SETTINGS - MAIN MENU LAYOUT (CONT)

DISPLAY TEXT	EXPANDED DISPLAY TEXT	VALUES	UNITS	DEFAULT	POINT	ENTRY
<b>ECONOMIZER (cont)</b>	Economizer Configurations Menu					
<b>ECON MAX POS</b>	Econ Max Damper Position	0 to 100	%	100	DAMPMAX	
<b>ECON TRAVEL TIME</b>	Economizer Travel Time	5 to 300	sec	150	ECONOTRV	
<b>MINIMUM POSITION CONFIGS</b>	Minimum Position Configurations menu					
<b>MIN POS @ MAX FAN</b>	Econ Min at Max Fanspeed	0 to 100	%	30	MINP_MAX	
<b>MIN POS SPEED 1</b>	Min Pos - User Speed 1	0 to 100	%	0	MP_USPD1	
<b>MIN POS DAMP 1</b>	Min Pos - User Pos 1	0 to 100	%	0	MP_UPOS1	
<b>MIN POS SPEED 2</b>	Min Pos - User Speed 2	0 to 100	%	0	MP_USPD2	
<b>MIN POS DAMP 2</b>	Min Pos - User Pos 2	0 to 100	%	0	MP_UPOS2	
<b>MIN POS SPEED 3</b>	Min Pos - User Speed 3	0 to 100	%	0	MP_USPD3	
<b>MIN POS DAMP 3</b>	Min Pos - User Pos 3	0 to 100	%	0	MP_UPOS3	
<b>FREE COOL CONFIGS</b>	Free Cooling Specific Configurations Menu					
<b>LOW COOL SAT SP</b>	LowFree Cool SAT Setpnt	40 to 80	°F	65	LCSASP	
<b>HIGH COOL SAT SP</b>	High FreeCool SAT Setpnt	40 to 80	°F	55	HCSASP	
<b>FREE COOL MAX OAT</b>	Free Cooling Max OAT	0 to 90	°F	65	MAXFREET	
<b>FREE COOL MIN OAT</b>	Free Cooling Min Temp	-30 to 70	°F	0	MINFREET	
<b>DIFF DRY BULB CTL</b>	Diff. Dry Bulb Control	Enable/Disable		Disable	DIFFBULB	
<b>DIFF DB DEADBAND</b>	Diff. Dry Bulb Deadband	0 to 20	°F	3	OATRATDB	
<b>ENTHALPY HI LIMIT</b>	Max Enthalpy OA limit	1 to 99	BTU/LB	28	FREEMAXE	
<b>DIFF ENTHALPY CTL</b>	Diff. Enthalpy Control	Enable/Disable		Disable	DIFFENTH	
<b>ENTHALPY DEADBAND</b>	Enthalpy Cross Deadband	0 to 20	BTU/LB	2	OAERAEDB	
<b>UNOCCUPIED FREE COOL</b>	Unoccupied Free Cooling Configs Menu					
<b>WHEN TO UNOCC FC</b>	When to Unocc Free Cool?	0=Disabled, 1=PreOcc, 2=Unocc		1=PreOcc	UFC_CFG	
<b>UFC PREOCC TIME</b>	UFC PreOcc Time	1 to 999	min	120	UFCTIME	
<b>UFC LOW TEMP</b>	Unocc Free Cool Low Temp	-30 to 70	°F	50	OATLUFC	
<b>POWER EXHAUST CONFIGS</b>	Power Exhaust Configurations Menu					
<b>PE1 RELAY CHANNEL</b>	PE1 Relay Channel	0=NONE, 1=MBB RLY11, 2=MBB RLY06		0: no FIOP 2: FIOP	PE1_CHAN	
<b>PE1 POS @ MAX SPD</b>	PE Stage 1 at Max speed	0 to 100	%	40	PE1_PMAX	
<b>PE OFF DEADBAND</b>	PE Turn Off Dead band	0 to 100	%	5	PE_OFFFDB	
<b>PE2 RELAY CHANNEL</b>	PE2 Relay Channel	0=NONE, 1=MBB RLY11, 2=MBB RLY06		0=NONE	PE2_CHAN	
<b>PE2 POS @ MAX SPD</b>	PE Stage 2 At Max Speed	0 to 100	%	75	PE2_PMAX	
<b>ECON ACT MECH DISC DIAG</b>	Econ Actuator Mechanical disconnect diagnostic menu					
<b>MDD-H/C END DLY</b>	T24 Heat/Cool End Delay	0 to 60	min	25	T24CHDLY	
<b>MDD-MIN MOVE</b>	T24Econ Min Move for SAT	10 to 20	%	10	T24ECSTS	
<b>MDD-SAT DB</b>	Damper SAT deadband	0 to 20	°F	12	T24SATDB	
<b>MDD-MIN RAT-OAT</b>	T24 Min Diff in RAT-OAT	5 to 20	°F	15	T24RATDF	
<b>MDD-MIN TEST POS</b>	T24 Test Minimum Pos	0 to 100	%	15	T24TSTMN	
<b>MDD-MAX TEST POS</b>	T24 Test Maximum Pos	0 to 100	%	85	T24TSTMX	
<b>AIR QUALITY</b>	Air Quality Configurations Menu					
<b>ANALOG IAQ CTRL</b>	Analog Input IAQ Control	0=NO IAQ, 1=DCV, 2=IAQ OVRD, 3=CTRL MINP		0: no FIOP 1: FIOP	IAQANCFG	
<b>IAQ POS @ MAX SPD</b>	IAQ Position at Max Fan	0 to 100	%	10	IAQMNP	
<b>LOW AIR.Q DIFF</b>	AQ Differential Low	0 to 5000		100	DAQ_LOW	
<b>HGH AIR.Q DIFF</b>	AQ Differential High	0 to 5000		700	DAQ_HIGH	
<b>PREOCC PURGE ENBL</b>	IAQ Preoccupancy Purge	Yes/No		Yes	IAQPURGE	
<b>PURGE POS @ MAX</b>	IAQ Purge Pos at Max IDF	0 to 100	%	40	IAQPMAX	
<b>PREOCC LOW LIMIT</b>	Preocc Purge Lockout OAT	0 to 70	°F	50	IAQP_LA	
<b>PREOCC PURGE TIME</b>	Preocc Purge Duration	5 to 120	min	15	IAQPTIME	
<b>AQ DIF HI-IAQ OVR</b>	AQ Diff High IAQOVER-RIDE	0 to 5000	PPM	700	AQD_HIGH	

## SETTINGS - MAIN MENU LAYOUT (CONT)

DISPLAY TEXT	EXPANDED DISPLAY TEXT	VALUES	UNITS	DEFAULT	POINT	ENTRY
<b>AIR QUALITY (cont)</b>	Air Quality Configurations Menu					
<b>AQ DIF LO-IAQ OVR</b>	AQ Diff Low-IAQ OVERRIDE	0 to 5000	PPM	100	AQD_LOW	
<b>IAQ OVRRD ENABLE</b>	IAQ override enable	Yes/No		No	IAQOVREN	
<b>SW IAQ FAN CTRL</b>	Switch Input IAQ Fan ctl	0=Never, 1=Occupied, 2=Always		0=Never	IAQSWFAN	
<b>AI IAQ FAN CTRL</b>	Analog Input IAQ Fan ctl	0=Never, 1=Occupied, 2=Always		0=Never	IAQANFAN	
<b>AQ OVR POSITION</b>	IAQ Override Position	0 to 100	%	100	IAQOVPOS	
<b>ALARM RELAY</b>	Alarm Relay Configurations Menu					
<b>ALM RELAY CHANNEL</b>	ALM Relay Assigned Chan	0=NONE, 1=MBB RLY11, 2=MBB RLY06		1=MBB RLY11	ALM_CHAN	
<b>THERMOSTAT ALERTS</b>	Thermostat Alerts	Yes/No		Yes	TSTAT_AL	
<b>HARDWARE ALERTS</b>	Hardware Failures Alerts	Yes/No		Yes	HW_AL	
<b>SAT/RAT ALERTS</b>	SAT/RAT Sensor Alerts	Yes/No		Yes	SATRATAL	
<b>OAT SENSOR ALERTS</b>	OAT Thermistor Alerts	Yes/No		Yes	OATRL_AL	
<b>SPACE SENS ALERTS</b>	Space Sensors Alerts	Yes/No		Yes	SPACE_AL	
<b>TRANSDUCER ALERTS</b>	Transducer Sensor Alerts	Yes/No		Yes	TRANS_AL	
<b>RH SENSOR ALERTS</b>	RH sensor failure Alert	Yes/No		Yes	RHS_AL	
<b>CO2 SENSOR ALERTS</b>	Air Quality CO2 Alerts	Yes/No		Yes	CO2S_AL	
<b>OACFM SENS ALERTS</b>	OACFM Alarm Relay	Yes/No		No	OACFM_AL	
<b>ECONOMIZER ALERTS</b>	Economizer Alerts	Yes/No		Yes	ECON_AL	
<b>AIR FILTER ALERTS</b>	Dirty Filter Alerts	Yes/No		Yes	FILT_AL	
<b>GEN STATUS ALERTS</b>	General Status Alerts	Yes/No		Yes	GENS_AL	
<b>REFRIG CIR ALERTS</b>	Refrig Circuit Alerts	Yes/No		Yes	CKT_AL	
<b>COMPRESSOR ALERTS</b>	Compressor Alerts	Yes/No		Yes	COMP_AL	
<b>HEATING ALERTS</b>	Heating Failure Alerts	Yes/No		Yes	HEAT_AL	
<b>INDOOR FAN ALERTS</b>	Indoor Fan Alerts	Yes/No		Yes	FAN_AL	
<b>ON ACTIVE FAULTS</b>	Relay On Active Faults	Yes/No		Yes	FAULT_AL	
<b>SERVICE CONFIG MENU</b>	Service Configuration Menu					
<b>CMP FRAMEWORK</b>	Compressor Framework	0=1CIR 2CMP, 1=1CMP+LDR, 2=1CMP		1: All except below 2: 50FCQ 04-06	SYSVTYPE	
<b>ODF RELAY ENABLE</b>	ODF Relay Enabled	Yes/No		No: 50FCQ Yes: 50GCQ	OFR_EN	
<b>SHUTDWN A1 FIRST</b>	Comp A1 Shutdown First	Yes/No		No	SDWN_A1	
<b>SHUTDWN ALD FIRST</b>	Comp Loader Shutdown 1st	Yes/No		Yes: All except below No: 50FCQ 04-06	SDWN_ALD	
<b>IDF CURVE LO RPM</b>	IDF Curve Low End RPM	0 to 3000	RPM	189: Size 04 Standard Static Fan 219: Size 04 Medium Static Fan 249: Size 04 High Static Fan 190: Size 05 Standard Static Fan 217: Size 05 Medium Static Fan 246: Size 05 High Static Fan 230v 1 ph 266: Size 05 High Static Fan 230v 3ph, 460v, 575v 215: Size 06 Standard Static Fan 239: Size 06 Medium Static Fan 266: Size 06 High Static Fan 230v 1 ph 284: Size 06 High Static Fan 230v 3 ph, 460v, 575v 230: Size 07 Standard Static Fan 253: Size 07 Medium Static Fan 284: Size 07 High Static Fan	IFMLORPM	

## SETTINGS - MAIN MENU LAYOUT (CONT)

DISPLAY TEXT	EXPANDED DISPLAY TEXT	VALUES	UNITS	DEFAULT	POINT	ENTRY
<b>SERVICE CONFIG MENU (cont)</b>	Service Configuration Menu					
<b>IDF CURVE HI RPM</b>	IDF Curve High End RPM	0 to 3000	RPM	1890: Size 04 Standard Static Fan 2190: Size 04 Medium Static Fan 2490: Size 04 High Static Fan 1900: Size 05 Standard Static Fan 2170: Size 05 Medium Static Fan 2460: Size 05 High Static Fan 230v 1 ph 2660: Size 05 High Static Fan 230v 3ph, 460v, 575v 2150: Size 06 Standard Static Fan 2390: Size 06 Medium Static Fan 2660: Size 06 High Static Fan 230v 1 ph 2836: Size 06 High Static Fan 230v 3ph, 460v, 575v 2300: Size 07 Standard Static Fan 2530: Size 07 Medium Static Fan 2836: Size 07 High Static Fan	IFMHIRPM	
<b>CCH RELAY1 ENABLE</b>	CCH Relay 1 Enabled	Yes/No		Yes	CCHR1_EN	
<b>ECONO PID - KP</b>	ECONO PID - KP	0.00 to 99.90		2.5	ECONO_P	
<b>ECONO PID - KI</b>	ECONO PID - KI	0.00 to 99.90		0.12	ECONO_I	
<b>ECONO PID - KD</b>	ECONO PID - KD	0.00 to 99.90		1	ECONO_D	
<b>ECONO PID - RATE</b>	ECONO PID - RATE	10 to 180	sec	15	ECONO_DT	
<b>FBD PID - KP</b>	FBD PID - Kp	0 to 99.99		0.01	FBDPID_P	
<b>FBD PID - KI</b>	FBD PID Ki	0 to 99.999		0	FBDPID_I	
<b>FBD PID - KD</b>	FBD PID Kd	0 to 99.999		0	FBDPID_D	
<b>FBD KI RES VAL</b>	FBD Ki Reset Val.	0.00 to 99.90		0	FBDKIRES	
<b>NEW HARDWARE</b>	Quick Menu for New Hardware					
<b>UNIT CONTROL TYPE</b>	Unit Control Type	0=TSTAT, 1=SPACE SEN, 2=RAT SEN		0=TSTAT	CTRLTYPE	
<b>VENT METHOD</b>	Ventilation Method	0=NONE, 1=ECON, 2=2POS DMPR, 3=ERV, 4=ECON ERV		0: No FIOP 1: Economizer FIOP 2: Two Position Damper FIOP	VENTTYPE	
<b>SPRH SENS CHANNEL</b>	SPRH Assigned Channel	0=None, 1=MBB A106, 2=MBB A107, 3=MBB A108		0=NONE	SPRHCHAN	
<b>IAQ SENSOR CHAN</b>	IAQ Assigned Channel	0=None, 1=MBB A106, 2=MBB A107, 3=MBB A108		0: no FIOP 2: FIOP	IAQ_CHAN	
<b>OAQ SENSOR CHAN</b>	OAQ Assigned Channel	0=None, 1=MBB A106, 2=MBB A107, 3=MBB A108		0=NONE	OAQ_CHAN	
<b>OARH SENSOR CHAN</b>	OARH Assigned Channel	0=None, 1=MBB A106, 2=MBB A107, 3=MBB A108		0: no FIOP 3: FIOP	OARHCHAN	
<b>RARH SENS CHANNEL</b>	RARH Assigned Channel	0=None, 1=MBB A106, 2=MBB A107, 3=MBB A108		0=NONE	RARHCHAN	
<b>OACFM SENS CHANNEL</b>	OACFM Assigned Channel	0=None, 1=MBB A106, 2=MBB A107, 3=MBB A108, 4=SIOB A110		0=NONE	OACFMCHAN	

## SETTINGS - MAIN MENU LAYOUT (CONT)

DISPLAY TEXT	EXPANDED DISPLAY TEXT	VALUES	UNITS	DEFAULT	POINT	ENTRY
<b>NEW HARDWARE (cont)</b>	Quick Menu for New Hardware					
<b>FIRE SW CHANNEL</b>	Fire Switch Channel	0=None, 1=MBB DI12, 2=MBB DI13, 3=MBB DI14, 4=MBB DI02, 5=MBB DI03, 6=MBB Y3		0: No FIOP 5: FIOP	FIRECHAN	
<b>HUMSTAT CHANNEL</b>	Humidistat Status Chan.	0=None, 1=MBB DI12, 2=MBB DI13, 3=MBB DI14, 4=MBB DI02, 5=MBB DI03, 6=MBB Y3		0=NONE	HUMDCHAN	
<b>FILTER SW CHANNEL</b>	Filter Status Sw Channel	0=None, 1=MBB DI12, 2=MBB DI13, 3=MBB DI14, 4=MBB DI02, 5=MBB DI03, 6=MBB Y3		0: No FIOP 1: FIOP	FILTCHAN	
<b>REMOTE OCC CHAN</b>	Remote Occupancy Channel	0=None, 1=MBB DI12, 2=MBB DI13, 3=MBB DI14, 4=MBB DI02, 5=MBB DI03, 6=MBB Y3		0=NONE	RMOCCCHAN	
<b>REM.SHUTDOWN CHAN</b>	Remote Shutdown Channel	0=None, 1=MBB DI12, 2=MBB DI13, 3=MBB DI14, 4=MBB DI02, 5=MBB DI03, 6=MBB Y3		0=NONE	ROFFCHAN	
<b>COFS CHANNEL</b>	COFS Assigned Channel	0=None, 1=MBB DI12, 2=MBB DI13, 3=MBB DI14, 4=MBB DI02, 5=MBB DI03, 6=MBB Y3		0: No FIOP 4: FIOP	COFSCHAN	
<b>GEN STATUS CHAN</b>	General Status Channel	0=None, 1=MBB DI12, 2=MBB DI13, 3=MBB DI14, 4=MBB DI02, 5=MBB DI03, 6=MBB Y3		0=NONE	GEN_CHAN	
<b>ENTHALPY SW CHAN</b>	Enthalpy Sw Channel	0=None, 1=MBB DI12, 2=MBB DI13, 3=MBB DI14, 4=MBB DI02, 5=MBB DI03, 6=MBB Y3		0=NONE	ENTHCHAN	
<b>FAN STAT CHANNEL</b>	Fan Status Channel	0=None, 1=MBB DI12, 2=MBB DI13, 3=MBB DI14, 4=MBB DI02, 5=MBB DI03, 6=MBB Y3		0=NONE	FNSTCHAN	
<b>IAQ OVERRIDE SW CH</b>	IAQ override sw channel	0=None, 1=MBB DI12, 2=MBB DI13, 3=MBB DI14, 4=MBB DI02, 5=MBB DI03, 6=MBB Y3		0=NONE	IAQOCHAN	
<b>PHASE MON CHANNEL</b>	Phase Monitor Channel	0=None, 1=MBB DI12, 2=MBB DI13, 3=MBB DI14, 4=MBB DI02, 5=MBB DI03, 6=MBB Y3		0: No FIOP 3: FIOP	PMR_CHAN	

## SETTINGS - MAIN MENU LAYOUT (CONT)

DISPLAY TEXT	EXPANDED DISPLAY TEXT	VALUES	UNITS	DEFAULT	POINT	ENTRY
<b>NEW HARDWARE (cont)</b>	Quick Menu for New Hardware					
<b>SMOKE PURGE CHAN</b>	Smoke Purge Sw Channel	0=None, 1=MBB DI12, 2=MBB DI13, 3=MBB DI14, 4=MBB DI02, 5=MBB DI03, 6=MBB Y3		0=NONE	PURGCHAN	
<b>SMOKE PRESS CHAN</b>	Smoke Pressure Sw Chan	0=None, 1=MBB DI12, 2=MBB DI13, 3=MBB DI14, 4=MBB DI02, 5=MBB DI03, 6=MBB Y3		0=NONE	PRESCHAN	
<b>SMOKE EVAC CHAN</b>	Smoke Evacuation Sw Chan	0=None, 1=MBB DI12, 2=MBB DI13, 3=MBB DI14, 4=MBB DI02, 5=MBB DI03, 6=MBB Y3		0=NONE	EVACCHAN	
<b>NETWORK SETTINGS</b>	Building Network Configurations Menu					
<b>BAS PROTOCOL</b>	BAS Protocol Select	0=NONE, 1=CCN, 2=BACNET	x	0=NONE	BMS_CFG	
<b>NETWORK TIMEOUT</b>	Network Input Timeout	0 to 600	min	30	NETINTO	
<b>CCN</b>	CCN Network Configuration Menu					
<b>BUS NUMBER</b>	CCN Bus Number	0 to 239		0	CCNBUS	
<b>CCN ELEMENT #</b>	CCN Element Number	1 to 239		1	CCNADD	
<b>CCN BAUDRATE</b>	CCN Baud Rate	0=9600, 1=19200, 2=38400		2=38400	BAUDENUM	
<b>BROADCAST ACK?</b>	CCN Broadcast Ack'er	Yes/No		No	CCNBCACK	
<b>BROADCAST SCHEDL?</b>	Global Schedule Broadcast	Yes/No		No	CCN_GSBC	
<b>BROADCAST TIME?</b>	CCN Time Broadcast	Yes/No		No	CCNBC	
<b>BROADCAST OAT?</b>	Broadcast OAT On Network	Yes/No		No	OATBC	
<b>BROADCAST OARH?</b>	Broadcast OARH On Network	Yes/No		No	OARHBC	
<b>BROADCAST OAQ?</b>	Broadcast OAQ On Network	Yes/No		No	OAQBC	
<b>BROADCAST IAQ?</b>	Broadcast IAQ On Network	Yes/No		No	IAQBC	
<b>ALLOW G. OVERRIDE</b>	Allow Global Overrides	Yes/No		Yes	GLBLOVER	
<b>LOCATION</b>	Device Location	text			DEV_LOC	
<b>REFERENCE NUMBER</b>	Reference number	text			REF_NUM	
<b>BACNET</b>	BACnet network configuration menu					
<b>MAC ADDRESS</b>	BACnet Device Macaddress	1 to 127		01	BAC_MAC	
<b>BACNET BAUDRATE</b>	BACnet BMS baud rate	0=9600, 1=19200, 2=38400, 3=57600, 4=76800, 5=115200		4=76800	BAC_BAUD	
<b>AUTO ID SCHEME</b>	ALC Auto Id Scheme	Yes/No		Yes	AUID	
<b>BACNET AUTO ID</b>	BACnet ID Auto ID	Yes/No		Yes	BAC_AUID	
<b>BACNET ID</b>	BACnet ID Number	0 to 4194302		1610101	BAC_ID	
<b>LINKAGE SETTINGS</b>	LINKAGE SETTINGS MENU					
<b>DEVICE IAQ</b>	BACnet device for IAQ	0 to 4194303		1610100	DEVIAQ	
<b>OBJECT ID IAQ</b>	Object instance for IAQ	0 to 9999		1009	OBJIAQ	
<b>COV IAQ</b>	Change of value for IAQ	0 to 60		0	COVIAQ	
<b>DEVICE OAQ</b>	BACnet device for OAQ	0 to 4194303		1610100	DEVOAQ	
<b>OBJECT ID OAQ</b>	Object instance for OAQ	0 to 9999		1012	OBJOAQ	
<b>COV OAQ</b>	Change of value for OAQ	0 to 60		0	COVOAQ	
<b>DEVICE OARH</b>	BACnet device for OARH	0 to 4194303		1610100	DEVOARH	
<b>OBJECT ID OARH</b>	Object instance for OARH	0 to 9999		1022	OBJOARH	
<b>COV OARH</b>	Change of value for OARH	0 to 60		0	COVOARH	
<b>DEVICE OAT</b>	BACnet device for OAT	0 to 4194303		1610100	DEVOAT	
<b>OBJECT ID OAT</b>	Object instance for OAT	0 to 9999		1003	OBJOAT	

## SETTINGS - MAIN MENU LAYOUT (CONT)

DISPLAY TEXT	EXPANDED DISPLAY TEXT	VALUES	UNITS	DEFAULT	POINT	ENTRY
<b>BACNET (cont)</b>	BACnet network configuration menu					
<b>COV OAT</b>	Change of value for OAT	0 to 60		0	COVOAT	
<b>DEVICE RARH</b>	BACnet device for RARH	0 to 4194303		1610100	DEVRRARH	
<b>OBJECT ID RARH</b>	Object instance for RARH	0 to 9999		30	OBJRARH	
<b>COV RARH</b>	Change of value for RARH	0 to 60		0	COVRARH	
<b>DEVICE RAT</b>	BACnet device for RAT	0 to 4194303		1610100	DEVRRAT	
<b>OBJECT ID RAT</b>	Object instance for RAT	0 to 9999		1010	OBJRAT	
<b>COV RAT</b>	Change of value for RAT	0 to 60		0	COVRAT	
<b>DEVICE SPT</b>	BACnet device for SPT	0 to 4194303		1610100	DEVSPT	
<b>OBJECT ID SPT</b>	Object instance for SPT	0 to 9999		2007	OBJSPT	
<b>COV SPT</b>	Change of value for SPT	0 to 60		0	COVSPT	
<b>LOCAL_SHEDL_EDIT</b>	Allow Local Sched Edit	Yes/No	enum	No	LCL_EDIT	
<b>SYSTEM TOUCH</b>	System Touch Menu					
<b>DEVICE INSTANCE</b>	System Touch Device Inst	0 to 4194303		160099	DEVST	
<b>POLLING RATE</b>	System Touch Poll Rate	10 to 60		10	POLLST	
<b>SPACE TEMP AI</b>	System Touch AI for SPT	0 to 9999		1	AISTSPT	
<b>SPACE RH AI</b>	System Touch AI for SPRH	0 to 9999		4	AISTSPRH	
<b>ZS SENSOR CFG</b>	ZS Sensor Configuration					
<b>ZS1 ADDRESS</b>	Zone Sensor 1 Address	0 to 255		255	ZSADDR1	
<b>ZS2 ADDRESS</b>	Zone Sensor 2 Address	0 to 255		255	ZSADDR2	
<b>ZS3 ADDRESS</b>	Zone sensor 3 address	0 to 255		255	ZSADDR3	
<b>ZS4 ADDRESS</b>	Zone sensor 4 address	0 to 255		255	ZSADDR4	
<b>ZS5 ADDRESS</b>	Zone sensor 5 address	0 to 255		255	ZSADDR5	
<b>ZS POLL RATE</b>	Zone sensor poll rate	1 to 100	sec	5	ZSPOLLRT	
<b>ZS UNIT</b>	Zone sensor unit	0=degrees F		0=degrees F	ZSUNIT	
<b>ZS FRC UNOC ENBL</b>	ZS Force Unoccup enable	Yes/No		No	ZSFUNEN	
<b>ZS FRC UNOC DELAY</b>	ZS Force unocc wt delay	Yes/No		No	ZSFUNWT	
<b>ZS TLO CONT ENBL</b>	ZS TLO Cont Enable	Yes/No		No	ZSTLOEN	
<b>TLO SET DURING OC</b>	ZS TLO set during occ	Yes/No		No	ZSTLSOC	
<b>ZS UI MODE</b>	Zone sensor UI Mode	1=Dual Offsets		1=Dual Offsets	ZSUIM	
<b>NETWORK CHKLIST</b>	NETWORK SETUP CHECKLIST	0=Undone, 1=Perfom, 2=Done		0=Undone	CHK_NET	
<b>DISPLAY SETTINGS</b>	User Display Configurations Menu					
<b>METRIC DISPLAY</b>	Metric Display	Yes/No		No	DISPUNIT	
<b>LANGUAGE</b>	Display Language Select	0=English, 1=Spanish		0=English	LANGUAGE	
<b>CONTRAST ADJUST</b>	LCD Contrast Adjustment	1 to 10		5	LCD_CONT	
<b>PASSWORD ENABLE?</b>	User Password Protection	Enable/Disable		Enable	PASS_EBL	
<b>VIEW USER PASSWORD</b>	View User Password Menu					
<b>CHANGE USER PASSWORD</b>	Change User Password Menu					
<b>QUICK SETUP CONFIG</b>	QUICK SETUP CONFIG MENU					
<b>TIME</b>	Clock Hour and Minute	xx:xx			TIME	
<b>DATE</b>	Current Date	MM/DD/YYYY			DATE	
<b>STARTUP DELAY</b>	Unit Startup Delay	10 to 600	sec	30	STARTDLY	
<b>UNIT CONTROL TYPE</b>	Unit Control Type	0=TSTAT, 1=SPACE SEN, 2=RAT SEN		0=TSTAT	CTRLTYPE	
<b>THERMOSTAT TYPE</b>	Thermostat Hardware Type	0=CONV 2C2H, 1=DIGI 2C2H, 2=CONV 3C2H, 3=DIGI 3C2H		0=CONV 2C2	STATTYPE	
<b>DIRTY FILTER TIME</b>	Change Filter Timer	0 to 9999	hrs	0	FILT LIFE	
<b>QUICK SETUP CONFIG</b>	QUICK SETUP CONFIG MENU					
<b>TIME BTWN DEFROST</b>	Min Time BTWN Defrosts	30 to 120	min	60	MINDFINT	
<b>HEATING STAGE QTY</b>	Number of Heating Stages	0 to 2		1	NUMHSTGS	
<b>VENT METHOD</b>	Ventilation Method	0=NONE, 1=ECON, 2=2POS DMPR, 3=ERV, 4=ECON ERV		0: No FIOF 1: Economizer FIOF 2: Two Position Damper FIOF	VENTTYPE	
<b>FREE COOL MAX OAT</b>	Free Cooling Max OAT	0 to 90	°F	65	MAXFREET	



## SETTINGS - MAIN MENU LAYOUT (CONT)

DISPLAY TEXT	EXPANDED DISPLAY TEXT	VALUES	UNITS	DEFAULT	POINT	ENTRY
QUICK SETUP CONFIG	QUICK SETUP CONFIG MENU					
FIRE SW CHANNEL	Fire Switch Channel	0=None, 1=MBB DI12, 2=MBB DI13, 3=MBB DI14, 4=MBB DI02, 5=MBB DI03, 6=MBB Y3		0: No FIOP 5: FIOP	FIRECHAN	
IDF LOW COOL SPD	IDF Low Cool Speed-RPM	0 to 3000	RPM	1106: Size 04 Standard Static Fan 1281: Size 04 Medium Static Fan 1457: Size 04 High Static Fan 1112: Size 05 Standard Static Fan 1269: Size 05 Medium Static Fan 1439: Size 05 High Static Fan 230v 1 ph 1556: Size 05 High Static Fan 230v 3ph, 460v, 575v 1258: Size 06 Standard Static Fan 1398: Size 06 Medium Static Fan 1556: Size 06 High Static Fan 230v 1 ph 1659: Size 06 High Static Fan 230v 3ph, 460v, 575v 1184: Size 07 Standard Static Fan 1302: Size 07 Medium Static Fan 1460: Size 07 High Static Fan	RPM_LCL	
IDF HIGH COOL SPD	IDF High Cool Speed-RPM	0 to 3000	RPM	1474: Size 04 Standard Static Fan 1708: Size 04 Medium Static Fan 1942: Size 04 High Static Fan 1482: Size 05 Standard Static Fan 1693: Size 05 Medium Static Fan 1919: Size 05 High Static Fan 230v 1 ph 2075: Size 05 High Static Fan 230v 3ph, 460v, 575v 1677: Size 06 Standard Static Fan 1864: Size 06 Medium Static Fan 2075: Size 06 High Static Fan 230v 1 ph 2212: Size 06 High Static Fan 230v 3ph, 460v, 575v 1794: Size 07 Standard Static Fan 1973: Size 07 Medium Static Fan 2212: Size 07 High Static Fan	RPM_HCL	
IDF VENT SPD	IDF Vent Speed-RPM	0 to 3000	RPM	same as IDF LOW COOLSPD	RPM_VENT	
IDF HEAT SPD	IDF Heat Speed-RPM	0 to 3000	RPM	same as IDF HIGH COOL SPD	RPM_HEAT	
QUICK SET CHKLIST	QUICK SETUP CHECKLIST	0=Undone, 1=Perfom, 2=Done		0=Undone	CHK_QUIK	



**UNIT START-UP CHECKLIST**  
(Remove and Store in Job File)

**NOTE: To avoid injury to personnel and damage to equipment or property when completing the procedures listed in this start-up checklist, use good judgment, follow safe practices, and adhere to the safety considerations/information as outlined in the preceding sections of this Installation Instructions document.**

MODEL NO: \_\_\_\_\_

DATE: \_\_\_\_\_

SERIAL NO: \_\_\_\_\_

TECHNICIAN: \_\_\_\_\_

**I. PRE-START-UP:**

- Verify that all packaging materials have been removed from unit (Y/N) \_\_\_\_\_
- Verify installation of outdoor air hood (Y/N) \_\_\_\_\_
- Verify that condensate connection is installed per installation instructions (Y/N) \_\_\_\_\_
- Verify that all electrical connections and terminals are tight (Y/N) \_\_\_\_\_
- Check that indoor-air filters are clean and in place (Y/N) \_\_\_\_\_
- Check that outdoor air inlet screens are in place (Y/N) \_\_\_\_\_
- Verify that unit is level (Y/N) \_\_\_\_\_
- Check outdoor fan propeller for location in housing/orifice and verify setscrew is tight (Y/N) \_\_\_\_\_
- Verify that scroll compressors are rotating in the correct direction (Y/N) \_\_\_\_\_
- Verify installation of thermostat/space sensor (Y/N) \_\_\_\_\_
- Verify configuration values for electronic controls (Refer to Control Set Up Checklist) (Y/N) \_\_\_\_\_
- Verify that crankcase heaters have been energized for at least 24 hours (Y/N) \_\_\_\_\_

**II. START-UP**

**ELECTRICAL**

Supply Voltage	L1-L2 _____	L2-L3 _____	L3-L1 _____	
Compressor Amps	— Unloaded	L1 _____	L2 _____	L3 _____
	— with Loader	L1 _____	L2 _____	L3 _____
Electric Heat Amps (if equipped)		L1 _____	L2 _____	L3 _____
Supply Fan Amps at Max Speed		L1 _____	L2 _____	L3 _____

**TEMPERATURES**

Outdoor-Air Temperature	_____ F DB (Dry Bulb)	_____ F WB (Wet Bulb)
Return-Air Temperature	_____ F DB	_____ F WB
Cooling Supply Air	_____ F DB	_____ F WB
Electric Heat Supply Air	_____ F	_____ F

**PRESSURES**

Refrigerant Suction \_\_\_\_\_ psig

Refrigerant Discharge \_\_\_\_\_ psig

Verify refrigerant charge using charging charts (Y/N) \_\_\_\_\_

**GENERAL**

Economizer minimum vent and changeover settings to job requirements (Y/N) \_\_\_\_\_

CUT ALONG DOTTED LINE

CUT ALONG DOTTED LINE