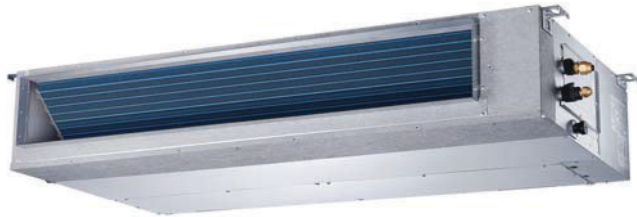


# Installation Instructions



**Fig. 1 — Sizes 09K - 48K**

**NOTE:** The 09K-48K unit can be mounted vertically as well as horizontally.



**Fig. 2 — Size 58K**

**NOTES:** Read the entire instruction manual before starting the installation.

Images are for illustration purposes only. Actual models may differ slightly.

## TABLE OF CONTENTS

SAFETY CONSIDERATIONS .....	2
INTRODUCTION .....	3
INSTALLATION REQUIREMENTS .....	4
DIMENSIONS .....	5
INSTALLATION CLEARANCES HORIZONTAL INSTALLATIONS .....	7
MAINTENANCE CLEARANCES .....	7
INSTALLATION .....	8
Step 1 - Check Equipment .....	8
Step 2 - Mount Unit .....	8
Step 3 - Installing Ductwork .....	10
Step 4 - Condensate Drain Installation .....	11
Step 5 - Electrical Connections .....	14
WIRING .....	15
ELECTRICAL DATA .....	16
CONNECTION DIAGRAMS .....	16
Step 6 - Refrigerant Piping .....	17
WIRELESS REMOTE CONTROLLER INSTALLATION .....	18
WIRED REMOTE CONTROLLER INSTALLATION .....	18
START-UP .....	18
Step 7 - Setting Static Pressure or Automatic Airflow .....	19
FAN PERFORMANCES AT VARYING STATIC PRESSURES .....	20
SYSTEM CHECKS .....	26
TROUBLESHOOTING .....	27
ADVANCED SERVICE AND INSTALLATION FUNCTIONS .....	28


## SAFETY CONSIDERATIONS

Improper installation, adjustment, alteration, service, maintenance, or use can cause explosion, fire, electrical shock, or other conditions which may cause death, personal injury or property damage.

Consult a qualified installer, service agency, or your distributor or branch for information or assistance. The qualified installer or agency must use factory-authorized kits or accessories when modifying this product. Refer to the individual instructions packaged with kits or accessories when installing.

Follow all safety codes. Wear safety glasses, protective clothing and work gloves. Have a fire extinguisher available. Read these instructions thoroughly and follow all warnings or cautions included in the literature and attached to the unit. Consult local building codes and the current editions of the National Electrical Code (NEC) NFPA 70.

In Canada, refer to the current editions of the Canadian Electrical Code CSA C22.1. Recognize safety information.

This is the safety-alert symbol . When you see this symbol on the unit and in instruction manuals, be alert to the potential for personal injury.



### WARNING

The 9K and 12K units are for single room applications **only**.



### WARNING

#### ELECTRICAL OPERATION HAZARD

Failure to follow this warning could result in personal injury or death.

Before installing or servicing unit, always turn off all power to the unit. There may be more than one disconnect switch. Turn off the accessory heater power if applicable. Lock out and tag switch with a suitable warning label.



### WARNING



#### EXPLOSION HAZARD

Failure to follow this warning could result in death, serious personal injury, and/or property damage.

Never use air or gases containing oxygen for leak testing or operating refrigerant compressors. Pressurized mixtures of air or gases containing oxygen can lead to an explosion.



### CAUTION

#### EQUIPMENT DAMAGE HAZARD

Failure to follow this caution may result in equipment damage or improper operation.

Do not bury more than 36 in. (914 mm) of refrigerant pipe in the ground. If any section of pipe is buried, there must be a 6 in. (152 mm) vertical rise to the valve connections on the outdoor units. If more than the recommended length is buried, refrigerant may migrate to the cooler buried section during extended periods of a system shutdown. This causes refrigerant slugging and could possibly damage the compressor during the start-up process.



### CAUTION

#### CUT HAZARD

Failure to follow this caution may result in personal injury.

Sheet metal parts may have sharp edges or burrs. Use caution and wear appropriate protective clothing and gloves when handling parts.

# INTRODUCTION

The Ducted Slim models are R-410A fan coils designed with application flexibility in mind. The 9K-48K sizes can be mounted horizontally or vertically (upflow) while the 58K size can be mounted only horizontally.

A rear and bottom return is available for field modification on the 9K-48K sizes to match the different applications.


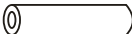




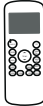



All these fan coils have a DC fan motor with variable speeds for efficiency and comfort. The static pressure can be manually set up or use the constant air volume control.

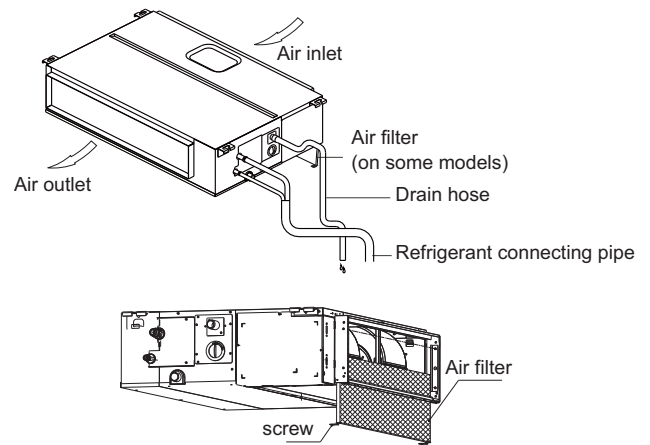
The ducted fan coil unit is shipped with a condensate lift pump providing a maximum lift of 29.5in (750mm).

## ACCESSORIES

The system is shipped with the following accessories. Use all of the installation parts and accessories to install the system. Improper installation may result in water leakage, electrical shock and fire, or cause the equipment to fail. Keep the installation manual in a safe place and do not discard any other accessories until the installation work has been completed.

**Table 1 — Accessories**

ACCESSORY	QUANTITY	SHAPE
Literature package including owner's manuals, installation instructions and warranty card	3	
Soundproof/insulation sheath	2	
Brass flare nut	2	
Drain adapter	1	
Air filter	1	
Wired controller <b>NOTE:</b> New Wired Remote Controller starting on production of week 28 year 2020 (serial number 2820V10001)	1	
Wireless remote controller	1	
Infrared Display Panel and extension wire	1	
Condensate Lift Pump (external sizes 09K-18K, internal sizes 24K-58K)	1	
EMC Ferrite core (magnetic ring)	1	
Optional Return Temperature Sensor p/n 40VM900009 - sold separately	1	



**Fig. 3 — Indoor Unit Representation**

### NOTES:

- If the outdoor unit is higher than the indoor unit, prevent rain from flowing into the indoor unit along the connection pipe by creating a downward arc in the connection pipe before it enters the wall and enters the indoor unit. Doing so helps ensure rain drips from the connection pipe before it enters the wall.
- Piping and the interconnecting wiring are field supplied.
- Fig. 3 is a sketch. Different models may differ slightly.

**Table 2 — Indoor Unit Model Numbers**

KBTUH	V-PH-HZ	ID MODEL NO.
9	208/230-1-60	40MBDQ09---3
12		40MBDQ12---3
18		40MBDQ18---3
24		40MBDQ24---3
36		40MBDQ36---3
48		40MBDQ48---3
58		40MBDQ58---3

## INSTALLATION REQUIREMENTS

- Confirm that the ceiling or wall can support the unit's weight.
- Confirm there is enough room within the false ceiling for installation and maintenance.
  - a. The false ceiling should be horizontal and leveled.
- Install the unit in a location within the room that allows uniform airflow in all directions.
- Do not install the indoor units near a direct source of heat such as direct sunlight or a heating appliance.
- Allow sufficient space for airflow and unit servicing. See Fig. 7 — on page 7 for the minimum required distances between the unit and the walls or ceilings.
- All wiring and refrigerant lines must be at least 3 ft. (1m) away from all electromagnetic interference (televisions, radios, etc.) sources. Interference is still possible even if this distance is maintained.
- Ensure the hanger is strong enough to withstand the unit's weight.
- **If the indoor unit is installed in an unconditioned space, running for long periods of time when the temperatures are outside the recommended indoor unit operation ranges, you are advised to seal all the corners of the indoor unit to prevent any leakage and add insulation material (1/2 to 3/4 in (10-20 mm)) to the entire surface of the indoor unit to avoid condensation or heat transfer.**

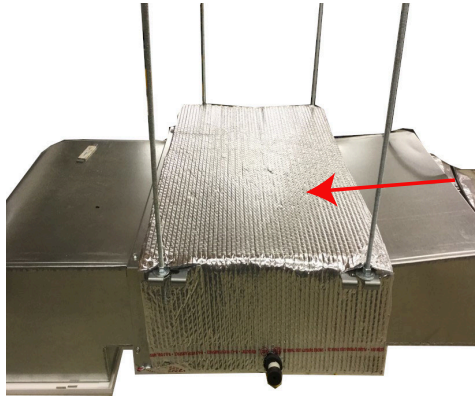


Fig. 4 — Insulation Material

**NOTE:** Nuisance sweating may occur if the unit is installed in a high humidity environment with low airflow.

Table 3 — Operating Range

	OPERATING RANGE MIN/MAX °F (°C)	
	Cooling	Heating
Indoor DB	63 / 90 (17 / 32)	32 / 86 (0 / 30)
Indoor WB	59 / 84 (15 / 29)	

If the unit is installed outside the operating range it is recommended to install a return air temperature button sensor. See "RETURN AIR ARRANGEMENT (SIZES 09K-48K ONLY)" on page 10.

**NOTE: DO NOT** install the indoor or outdoor units in a location with special environmental conditions. For those applications, contact your Ductless representative.



## WARNING

### PRODUCT INSTALLATION

- Installation must be performed by an authorized dealer or specialist. A defective installation can cause water leakage, electrical shock, or fire.
- The installation must be performed according to the installation instructions. Improper installation can cause water leakage, electrical shock, or fire. (In North America, installation must be performed in accordance with the requirements of NEC or CEC by authorized personnel only.)
- Contact an authorized service technician for repair or maintenance of this unit. This appliance must be installed in accordance with local codes.
- Only use the included accessories, parts, and specified parts for installation. Using non-standard parts can cause water leakage, electrical shock, fire, or unit failure.
- Install drainage piping according to the instructions in this manual. Improper drainage may cause water damage to your home and property.
- For units that have an auxiliary electric heater, **DO NOT** install the unit within 3 feet (1 meter) of any combustible materials.
- **DO NOT** install the unit in a location that may be exposed to combustible gas leaks. If combustible gas accumulates around the unit, it may cause a fire.
- **DO NOT** turn on the power until all work has been completed.
- When moving or relocating the system, consult experienced service technicians for the disconnection and re-installation of the unit.



## WARNING

Securely install the indoor unit on a structure that can sustain its weight. If the structure is too weak, the unit may fall and cause personal injury, unit and property damage, or death. **DO NOT** install the indoor unit in a bathroom or laundry room as excessive moisture can short the unit and corrode the wiring.



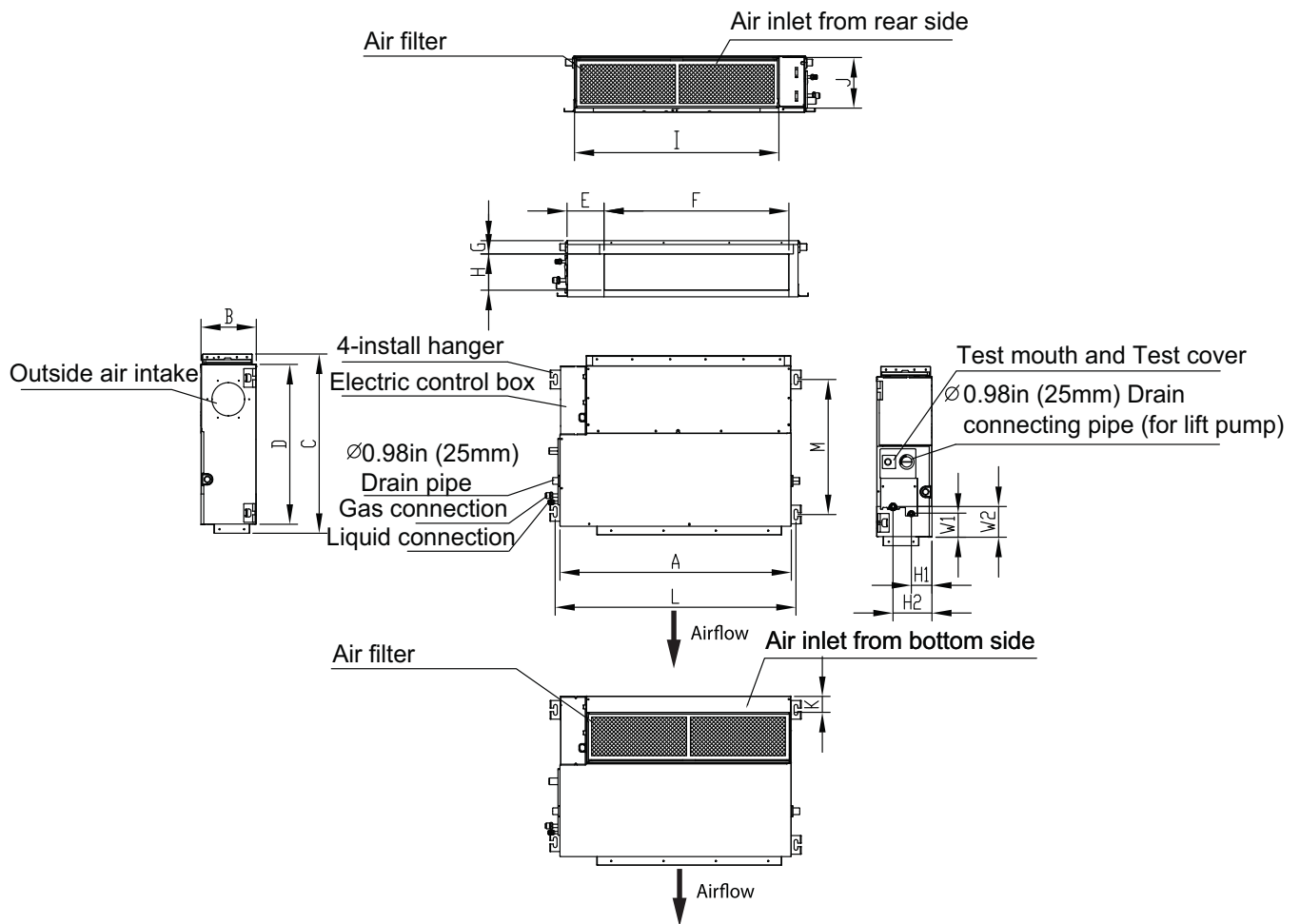
## CAUTION

Install the indoor and outdoor units, cables and wires at least 3.2 ft (1m) from televisions or radios to prevent static or image distortion. Depending on the appliances, a 3.2 ft (1m) distance may not be sufficient. If the indoor unit is installed on metal, it must be electrically grounded.

# DIMENSIONS

Table 4 — Indoor Unit Dimensions

Size	Unit	AIR OUTLET OPENING SIZE				AIR OUTLET OPENING SIZE				AIR INLET OPENING SIZE			HANGER BRACKETS		REFRIGERANT PIPE LOCATIONS				OPERATING WEIGHT LB (KG)
		A	B	C	D	E	F	G	H	I	J	K	L	M	H1	H2	W1	W2	
9	In.	27.6	7.9	19.9	17.7	5.4	21.1	1.2	6	23.6	7.3	2	29.2	14.2	3.3	5.5	3.3	3.3	40
	mm	700	200	506	450	137	537	30	152	599	186	50	741	360	84	140	84	84	18.1
12	In.	27.6	7.9	19.9	17.7	5.4	21.1	1.2	6	23.6	7.3	2	29.2	14.2	3.3	5.5	3.3	3.3	40
	mm	700	200	506	450	137	537	30	152	599	186	50	741	360	84	140	84	84	18.1
18	In.	34.65	8.27	26.54	23.62	5.51	27.80	1.97	5.35	30.79	7.48	1.57	36.22	20	3.07	5.83	3.46	4.41	54
	mm	880	210	674	600	140	706	50	136	782	190	40	920	508	78	148	88	112	24.5
24	In.	43.31	9.8	30.47	27.56	5.51	36.46	1.97	6.89	39.41	8.98	0.2	44.88	23.54	3.15	5.91	5.12	6.1	87
	mm	1100	249	774	700	140	926	50	175	1001	228	5	1140	598	80	150	130	155	39.4
36	In.	53.54	9.8	30.47	27.56	5.51	46.69	1.97	6.89	49.65	8.98	0.2	55.12	23.54	3.15	5.91	5.12	6.1	106
	mm	1360	249	774	700	140	1186	50	175	1261	228	5	1400	598	80	150	130	155	48.3
48	In.	47.24	11.81	34.41	31.5	4.84	41.1	1.97	8.94	43.35	11.02	0.2	48.82	27.44	3.15	5.91	7.28	8.27	120
	mm	1200	300	874	800	123	1044	50	227	1101	280	5	1240	697	80	150	185	210	54.3
58	In.	55.12	17.32	33.78	30.31	4.17	46.81	1.1	15.16	46.54	11.02	1.57	56.57	27.56	8.15	10.75	5.67	5.67	163
	mm	1400	440	858	770	106	1189	28	385	1182	280	40	1437	700	207	273	144	144	74



NOTE: Sizes 09K-48K blow-through systems

Fig. 5 — Indoor Unit Sizes 09K - 48K

# DIMENSIONS (CONT)

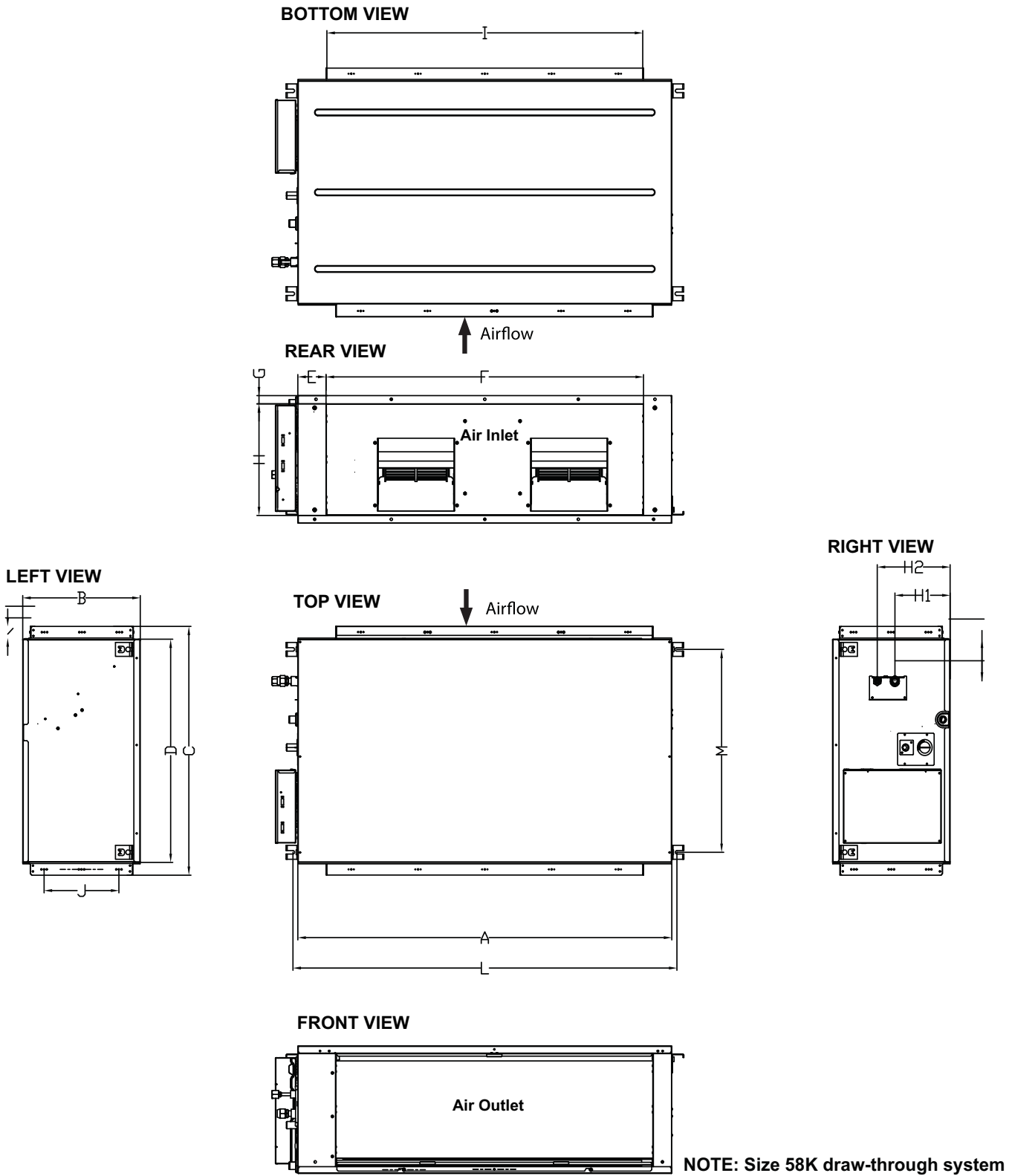


Fig. 6 — Indoor Unit Size 58K

# INSTALLATION CLEARANCES HORIZONTAL INSTALLATIONS

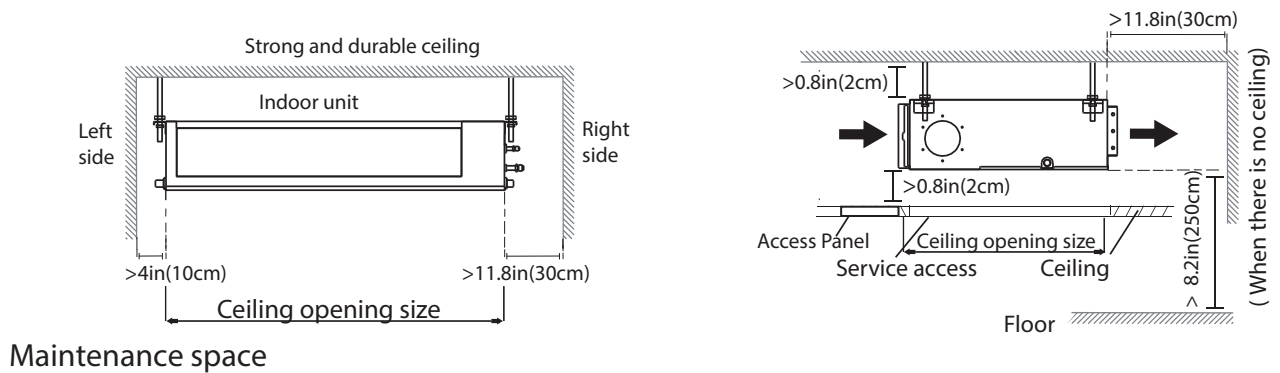


Fig. 7 — Installation Clearances

## MAINTENANCE CLEARANCES

Provide a service access for inspection purposes.

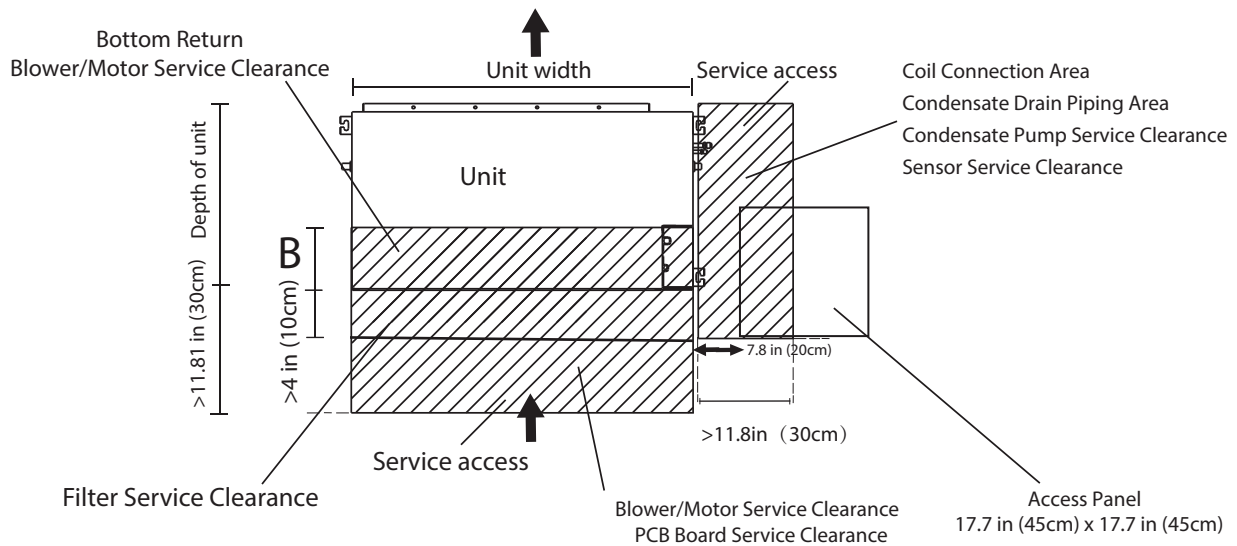


Fig. 8 — Maintenance Clearances

Table 5 — Maintenance Clearances

CAPACITY (KBTU)	B
9K	11.81in.(30cm)
12K	11.81in.(30cm)
18K	11.81in.(30cm)
24K	11.81in.(30cm)
36K	11.81in.(30cm)
48K	15.75in.(40cm)
58K	15.75in.(40cm)

**NOTE:** If installed above a fixed ceiling, utilize a ceiling access panel the length and width of the unit, otherwise the blower components and/or entire unit cannot be removed.

If a single access panel is desired, the minimum dimensions should be:

- **Single Access Panel Width:** The width of the unit plus 2-inches on both sides
- **Single Access Panel Length:** The length of the unit plus 18-inches on the connection end and 2-inches on the opposite end.

# INSTALLATION

## Step 1 - Check Equipment

Unpack the unit and move to the final location. Remove the carton, taking care not to damage the unit. Inspect the equipment for damage prior to installation. File a claim with the shipping company if the shipment is damaged or incomplete.

Locate the unit rating plate which contains the proper installation information. Check the rating plate to ensure the unit matches the job specifications.

**⚠ CAUTION**

Ensure the ceiling grid is supported separately from the unit.  
The ceiling grid must not be supported by any part of the unit or any associated wiring or piping work.

## Step 2 - Mount Unit

The unit can stand or lie on the floor, or hang from the ceiling or the wall. Allow adequate space for wiring, piping, and servicing of the unit. The 09K-48K size units can be mounted horizontally or vertically (upflow). The 58K units can be mounted horizontally.

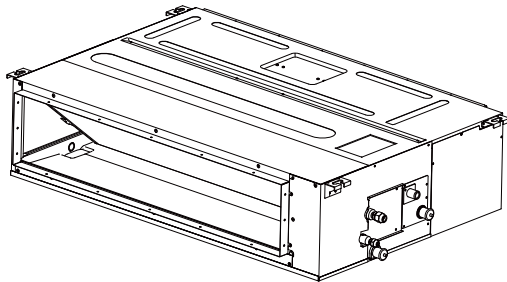


Fig. 9 — Unit mounted horizontally

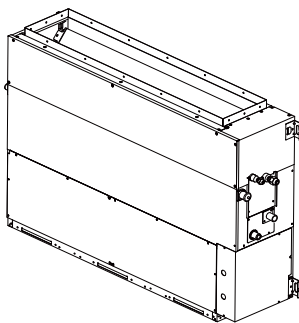


Fig. 10 — Unit mounted vertically (upflow)

**IMPORTANT:** When the unit is installed over a finished ceiling and/or a living area, building codes may require the installation of a field-supplied secondary condensate pan under the entire unit.

Some localities may allow as an alternative, the running of a separate, secondary condensate line. Consult the local codes for additional restrictions or precautions.

## Ceiling Mounting Options

Different ceiling types call for different mount applications.

### Wood

Place the wood mounting across the roof beam, then install the hanging screw bolts.

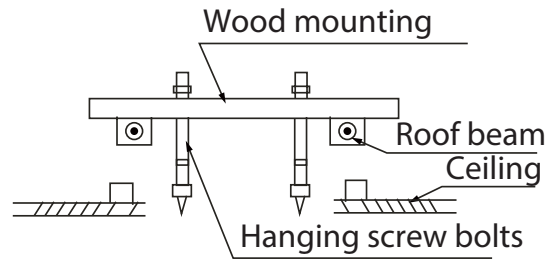


Fig. 11 — Wood Mounting

### New Concrete Bricks

Inlay or embed the screw bolts.

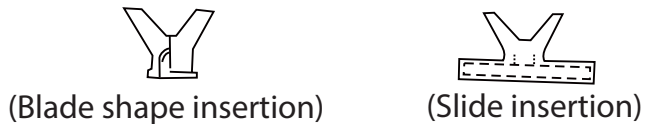


Fig. 12 — New Concrete Bricks

### Original Concrete Bricks

Use an embedding screw bolt, crock, and stick harness.

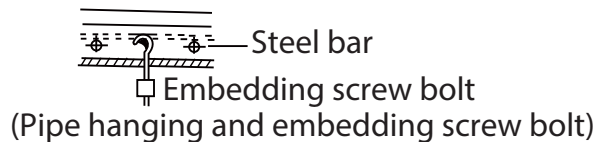


Fig. 13 — Original Concrete Bricks

### Steel Roof Beam Structure

Install and use the supporting steel angle.

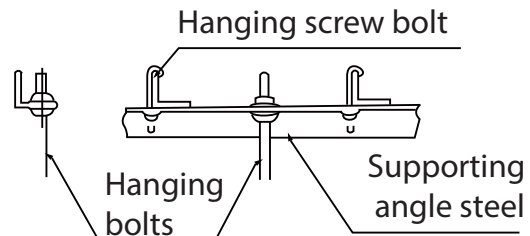


Fig. 14 — Steel Roof Beam

**⚠ CAUTION**

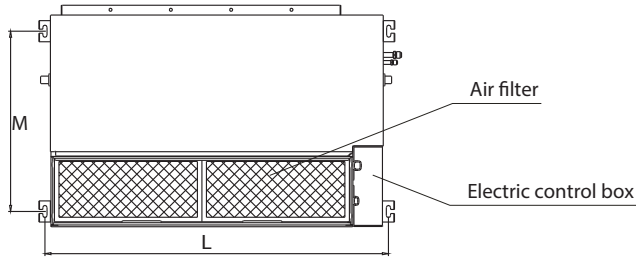
The unit body must be completely aligned with the hole. Ensure the unit and the hole are the same size before moving on.



Provide adequate space for wiring, piping, and servicing of the unit (see “INSTALLATION REQUIREMENTS” on page 4 and “MAINTENANCE CLEARANCES” on page 7).

**1. MARK AND DRILL HOLES TO HANG AND INSTALL THE BOLTS**

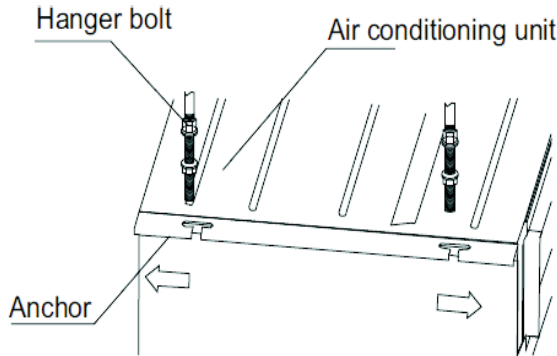
Mark the location of the four hanger bolt holes on the ceiling based on the indoor unit’s dimensional drawing. Drill four holes into the ceiling and install the four suspension bolts securing the bolt using the washers and nuts (field supplied). Use a Ø 0.39in (10mm) all-threaded rod.



**Fig. 15 — Bracket Positions**

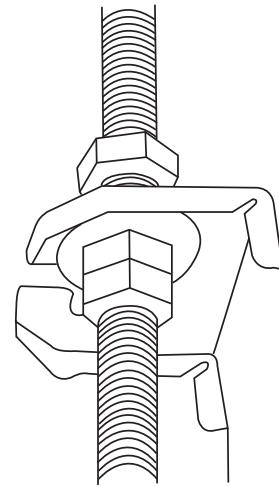
**Table 6 — Bracket Positions Dimensions**

Unit	L	M
In.(mm)	29.2(741)	14.2(360)
In.(mm)	29.2(741)	14.2(360)
In.(mm)	36.22(920)	20(508)
In.(mm)	44.88(1140)	23.54(598)
In.(mm)	55.12(1400)	23.54(598)
In.(mm)	48.82(1240)	27.44(697)
In.(mm)	56.57(1437)	27.56(700)



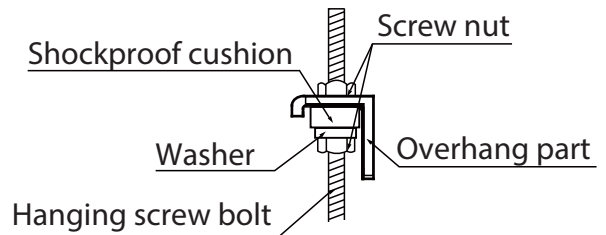
**Fig. 16 — Install the Hanger Bolts**

2. **THIS STEP REQUIRES TWO PEOPLE.** Lift the indoor unit to mount and secure it. Insert the suspension bolts into the unit’s hanging holes. Fasten the bolts with the washers and nuts provided.



**Fig. 17 — Suspension bolt**

3. Mount the indoor unit onto the hanging screw bolts with a block. Position the indoor unit with a level indicator to prevent leaks.
4. Adjust the unit’s height until the bottom is level with the false ceiling. Leave enough space to provide an adequate pitch for the drain.
5. Secure the unit in position with lock nuts and washers on both sides of the mounting bracket. Ensure the threaded rod does not extend more than 2 in. below the mounting brackets (see Fig. 18).



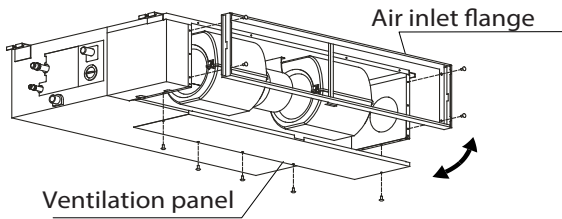
**Fig. 18 — Secure the Unit**

## RETURN AIR ARRANGEMENT (SIZES 09K-48K ONLY)

Based on the return air conditions in the field, the factory configured rear return arrangement of the unit may be modified to allow bottom return.

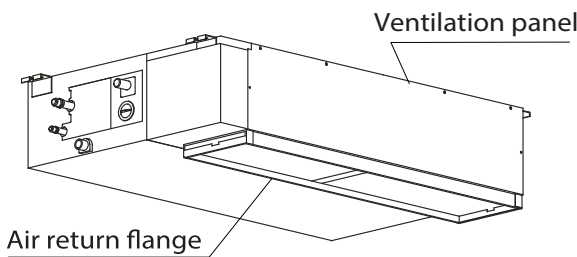
To modify:

1. Remove the Air Inlet Flange/filter rack and ventilation panel.



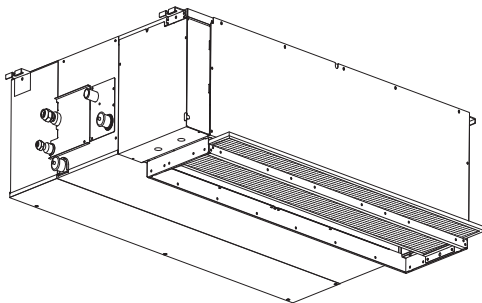
**Fig. 19 — Remove the Air Inlet Flange**

2. Install the seal on the bottom inlet.
3. Swap the position to change the rear return to a bottom return arrangement installing the Air Inlet flange and the filters.



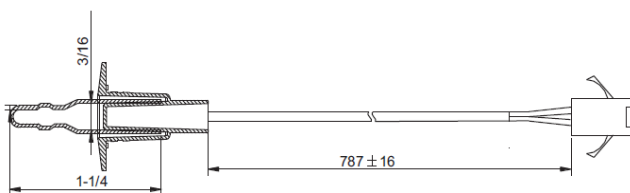
**Fig. 20 — Change the Rear Return**

4. Install the filter brackets to lock the filter in place.



**Fig. 21 — Install the Filter Brackets**

**Return Temperature Sensor** - A button sensor (p/n 40VM900009 - sold separately) may be used for situations where a indoor ducted unit is reading an inaccurate room temperature due to installation factors. The button sensor kit has a length of 66ft (20m). Replace the factory T1 sensor, which can be found inside the indoor unit. The sensor may be installed on the wall or ceiling. Airflow must be considered for accurate sampling.



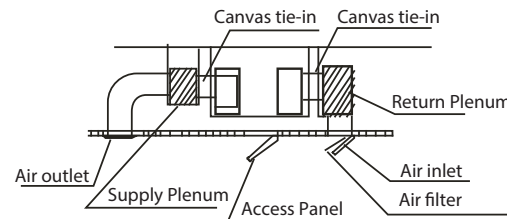
**Fig. 22 — Button Sensor**

**NOTE:** A temperature compensation correction may be necessary depending on the installation location of the unit. Consult the wireless remote controller's service manual for advanced steps on temperature compensation.

## Step 3 - Installing Ductwork

Connect the return and supply air ducts to the ducts over the outside flanges provided on the unit. Secure the canvas tie to the indoor unit's flange, using the proper fasteners for the type of duct used and the seal duct-to-unit joint. Use canvas duct (flexible connectors) between the ductwork and the unit to prevent transmission of vibration.

Maintain an adequate distance between the return and supply diffusers to avoid short circulation of air within the space. The filter is located on the return side of the unit, on the rear or bottom depending on the return air inlet arrangement.



**Fig. 23 — Installing Duct**

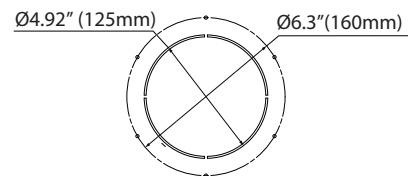
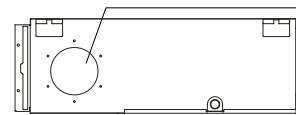
## OUTSIDE AIR CONNECTION

If needed, a knockout for the outside air duct connection is located on the side of the unit downstream of the air filter. Follow the recommendation to field supply and field install a booster fan on the duct work used for outside air. A relay to energize a booster fan may be powered by the connection on the PCB board CN43. This connection is 230 volt AC and rated for 200 watts.

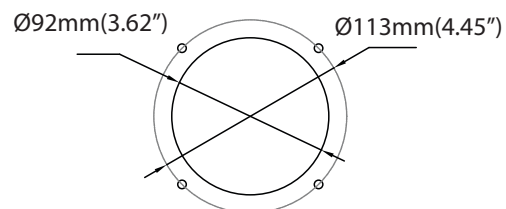
**NOTE:** The manufacturer recommends **NOT** powering the fan motor by this circuit.

The output of the NEW FAN (CN43) is powered **ON** while the indoor fan is active.

**NOTE:** The amount of outside air is dependent upon different factors such as the booster fan, outside air duct work type and length, static pressure, etc. Refer to the local IAQ specifications for the outdoor air quantities and control.



**Fig. 24 — Outside Air Connection Sizes 18K-58K**



**Fig. 25 — Outside Air Connection Sizes 09K-12K**

## Step 4 - Condensate Drain Installation

The condensate pipe is used to drain water away from the unit. Improper installation may cause unit and property damage. The unit is supplied with a drain adapter allowing the use of a field supplied 3/4 in. PVC Schedule 40 drain pipe. When installing the condensate piping, keep in mind the following details and follow these recommendations:

**NOTE:** When installing drains, be sure to adhere to the local sanitation codes.

- The ducted slim indoor unit is supplied with a condensate lift pump that is capable of lifting water 29.5in. (750mm).
- Ensure the highest point in the condensate piping is as close to the unit as possible (see Fig. 28).
- Ensure the condensate piping slopes downward in the direction of the condensate flow, with a minimum gradient of 1/100.
- When multiple units are connected to a common condensate drain, ensure the drain is large enough to accommodate the volume of condensate from all the units. Consider the recommendation to install an air vent in the condensate piping to prevent air lock.
- Do not install condensate piping where exposure to freezing temperatures is possible.
- To prevent the pipe from sagging, hangers should be spaced every 36 in (91.44cm). Be sure to follow local codes.
- If the drainpipe outlet is higher than the body's pump joint, provide a lift pipe for the indoor unit's exhaust outlet.
- Do not install the lift pipe higher than 21 in. (55cm) from the center line of the pump outlet pipe. The distance between the unit and the lift pipe must be less than 8 in (20cm). An incorrect installation could allow water to flow back into the unit and flood.
- To prevent air bubbles, keep the drain hose horizontal or slightly upward. See letter (A) Figure 28.

### CAUTION

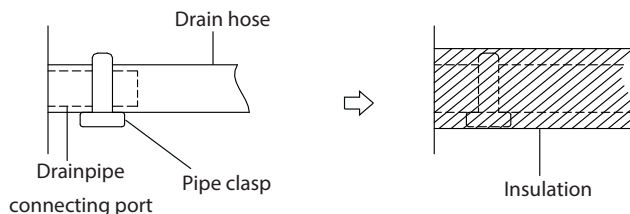
Insulate all piping to prevent condensation, which could lead to water damage.

If the drainpipe is bent or installed incorrectly, water may leak and cause a water-level switch malfunction.

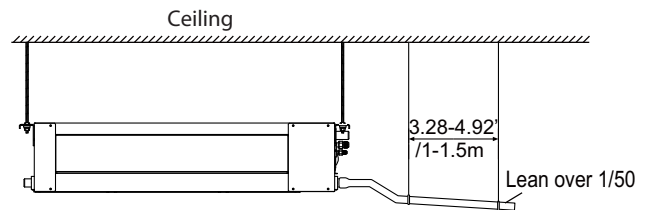
In **HEAT** mode, the outdoor unit discharges water. Ensure that the drain hose is placed in an appropriate area to avoid water damage and slippage.

**DO NOT** pull the drainpipe forcefully. This could disconnect it.

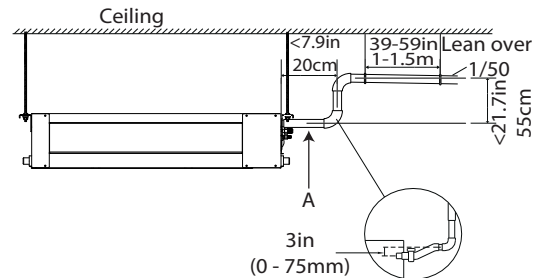
1. Cover the drain hose with heat insulation to prevent condensation and leakage.
2. Attach the mouth of the drain hose to the unit's outlet pipe. Sheath the mouth of the hose and clip it firmly with a pipe clasp (see Fig. 26).



**Fig. 26 — Indoor Drainpipe Installation**

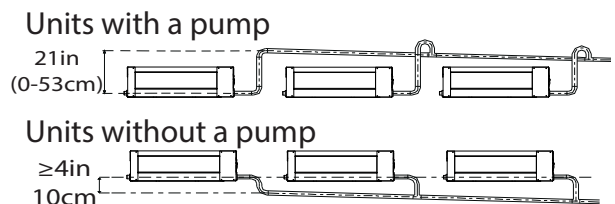


**Fig. 27 — Condensate piping without a pump**



**Fig. 28 — Condensate piping with a pump**

When connecting multiple drainpipes, install the pipes as shown in Fig. 29.



**Fig. 29 — Connecting Multiple Drain Pipes**

3. Pass the drain hose through the wall hole. Ensure the water drains to a safe location where it will not cause water damage or a slipping hazard.

**NOTE:** The drainpipe outlet should be at least 2in (5cm) above the ground. If the outlet touches the ground, the unit may become blocked and malfunction. If you discharge the water directly into a sewer, make sure the drain has a U or S pipe to catch odors that might otherwise come back into the house.

## CONDENSATE DRAIN AND CONDENSATE LIFT PUMP INSTALLATION (HORIZONTAL INSTALLATION)

For sizes 9, 12 and 18, the condensate lift pump is provided in a separate box. Use the following steps to install the External Condensate Lift Pump for a horizontal installation of the indoor unit.

**NOTE:** Drain connections A, B and C are covered with caps.

### 1. For sizes 09K and 12K:

- Remove the cap on the drainage outlet.
- Cut both ends of the rubber tubing provided into a straight one.
- Connect the drainage outlet and condensate lift pump using the rubber tubing and secure it with clamps on both ends (see Fig. 30).
- Plug the power cable of the external pump to CN13 / "PUMP" pin and plug the water level sensor cable to the CN5 / "WATER" to enable the pump (see Fig. 34).

### 2. For size 18K:

- Remove the cap on drain connector B.
- Connect drain connector B and the condensate lift pump using the L rubber hose and secure it with clamps on both ends.
- Connect the drainpipe to connector D (see Fig. 31).
- Plug the power cable of the external pump to CN13 / "PUMP" pin and plug the water level sensor cable to CN5 / "WATER" to enable the pump (see Fig. 34).

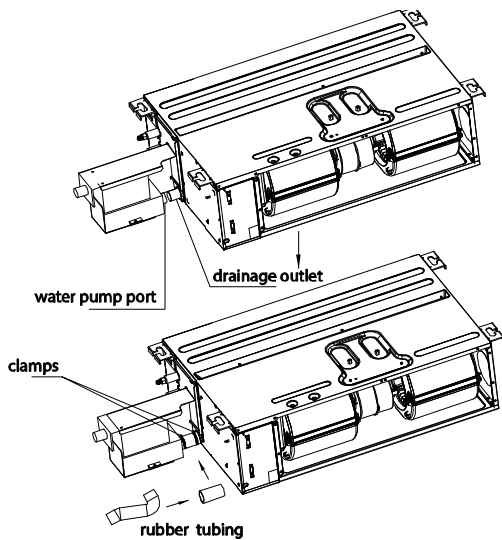


Fig. 30 — Condensate lift pump installation sizes 09K-12K

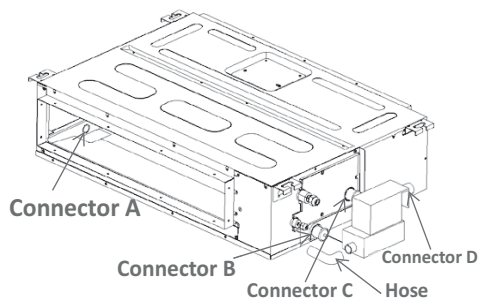


Fig. 31 — Condensate lift pump installation size 18K

- Sizes 24K, 36K, 48K and 58K have a built-in condensate lift pump. Drain connections (A, B and C) are covered with caps.

Connect the drainpipe to connector D (see Fig. 32).

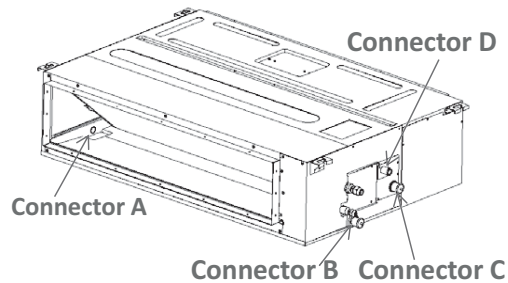


Fig. 32 — Connection of drain pipe to condensate lift pump sizes 24-58K

### Disabling the Condensate Lift Pump

**The pump must be disabled while the unit is installed vertically (upflow) or the lift pump assembly is removed from its original position:**

- Open the Control Box assembly cover, unplug the "CN13 PUMP" pin to disable the pump function, and short-connect the "CN5 WATER" plug to disable the water level sensor by either splicing the wires coming out of the CN5 WATER plug or by using a jumper plug Replacement Component part number 17401204000333 (optional in some units otherwise sold separately) (see Figures 33 and 34).

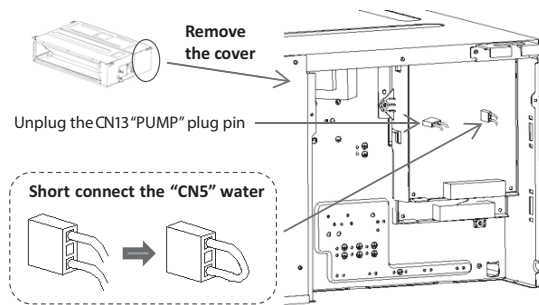


Fig. 33 — Disable condensate lift pump

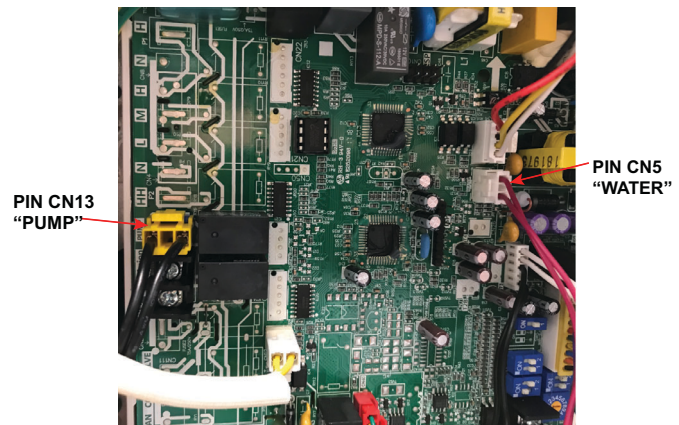


Fig. 34 — Condensate Lift Pump Connectors

Remove the cap from connector C and connect the condensate drain pipe to drain connector C (see Fig. 36).

**NOTE:** For size 18K, the external condensate lift pump should be removed (see Fig. 35).

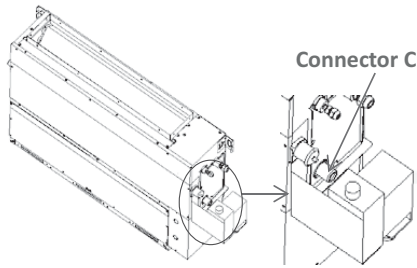


Fig. 35 — Sizes 9K, 12K, 18K with External Condensate Lift Pump

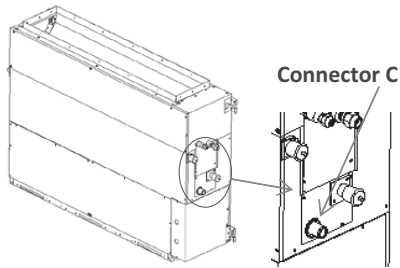


Fig. 36 — Sizes 24K to 48K with Built-in Condensate Lift Pump

### DRAINAGE TEST FOR UNITS WITHOUT A CONDENSATE LIFT PUMP

1. Ensure the drainpipe is unobstructed.
2. Fill the drain pan with 0.5 gallons (2 liters) of water.

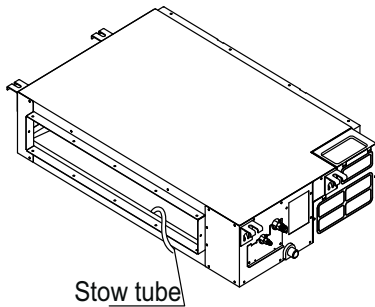


Fig. 37 — Units without a pipe

### CONDENSATE LIFT PUMP AND DRAINAGE TEST

Follow these steps to perform the test:

1. Remove the test cover by rotating it counter-clockwise (see Fig. 38).
2. Using a piece of tubing or pipe to fill the condensate lift pump reservoir with 70 oz. of water (see Fig. 39).
3. Turn the unit **ON** in the **COOLING** mode and the condensate lift pump turns on. Watch the end of the drain pipe for any water.

**NOTE:** It may take some time for the water to travel, depending on the length of the drain pipe.

4. During this test, check all bends or joints for leakage.

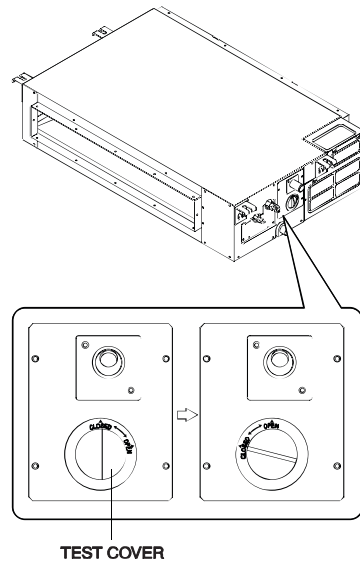


Fig. 38 — Check the Bends and Joints for Leakage

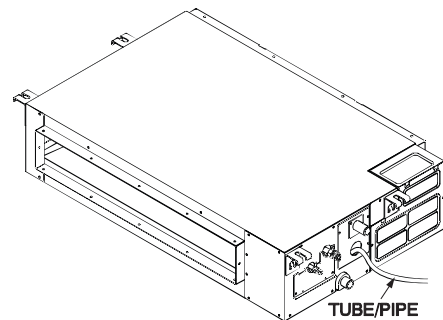


Fig. 39 — Tube Pipe Insert

### Condensate Lift Pump Maintenance

1. Remove the four screws from the drain pump (sizes 24K to 48K).
2. Unplug the pump power supply and the water level switch cable.
3. Detach the pump.

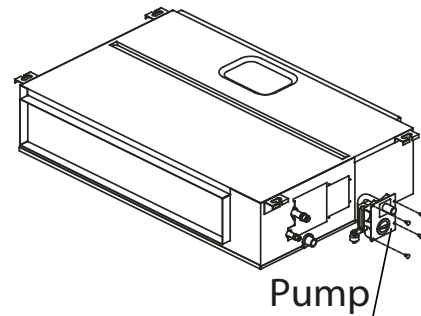


Fig. 40 — Detach the Pump

## Step 5 - Electrical Connections

Before proceeding with electrical connections, make certain that the supply voltage, frequency, phase, and ampacity are as specified on the unit rating plate. Review the unit wiring label for proper field high and low voltage wiring.


Ensure all electrical connections are in accordance with the NEC and any local codes or ordinances that may apply. Use copper wire only.


CAUTION

**PROPERTY DAMAGE HAZARD**

Failure to follow this caution may result in product or property damage.

If a disconnect switch is to be mounted on the unit, select a location where the drill or fastener will not contact electrical or refrigerant components.



WARNING

**ELECTRICAL SHOCK HAZARD**

Failure to follow this warning could result in personal injury or death.

Field wires on the line side of the disconnect found in the fan coil unit remain live, even when the pull-out is removed.

Service and maintenance to incoming wiring cannot be performed until the main disconnect switch (remote to the unit) is turned off.

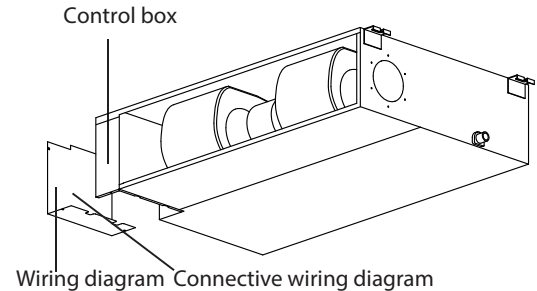

CAUTION

**EQUIPMENT DAMAGE HAZARD**

Failure to follow this caution may result in equipment damage or improper operation.

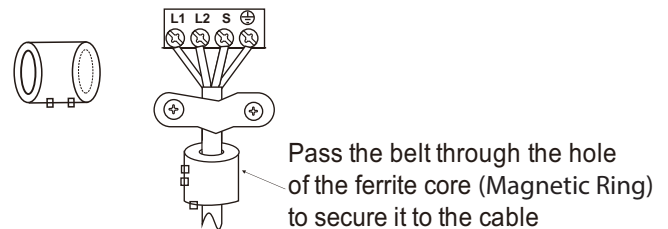
Size the wires in accordance with NEC and local codes.

1. Run an interconnecting wiring from the outdoor unit to the indoor unit.
2. Connect the wiring from the outdoor unit per the connection diagram (See Fig. 43 — on page 16 and See Fig. 44 — on page 16).
3. Prepare the cable for connection.
  - a. Use wire strippers to strip the rubber jacket from both ends of the signal cable to expose roughly 5.9in(15cm) of wire.
  - b. Strip the insulation from both ends of the wires.
  - c. Use a wire crimper to crimp the u-lugs to the end of the wires.
4. Remove the electric control box cover of the indoor unit.
5. Connect the u-lugs to the terminals. Match the wire colors/labels with the labels on the terminal block. Firmly screw the u-lug of each wire to its corresponding terminal. Refer to the serial number and wiring diagram located on the cover of the electric control box.



**Fig. 41 — Control Box**

**Ferrite Core (Magnetic Ring)** - If supplied and packed with the accessories, wrap the signal wires between the indoor unit and outdoor unit after installation and around the Ferrite core twice.



**Fig. 42 — Ferrite Core (Magnetic Ring)**

6. Clamp the cable with the cable clamp. Ensure the cable is not loose as to not pull on the u-lugs.
7. Replace the indoor unit field wiring cover.

# WIRING

Size all wires per the NEC (National Electrical Code) or CEC (Canadian Electrical Code) and local codes. Use the electrical data from the outdoor unit (MCA - minimum circuit amps and MOCP - maximum over current protection), to correctly size the wires and the disconnect fuse or breakers respectively.

## SIZES 09-24 RECOMMENDED CONNECTION METHOD FOR POWER AND COMMUNICATION WIRING

**Power and Communication Wiring:** The main power is supplied to the outdoor unit. The field supplied 14/3 power/communication wiring, from the outdoor unit to the indoor unit, consists of four (4) wires and provides the power for the indoor unit. Two wires are high voltage AC power, one is communication wiring and the other is a ground wire.

**To minimize communication interference:** If installed in a high Electromagnetic field (EMF) area and communication issues arise, a 14/2 stranded shielded wire can be used to replace L2 and (S) between the outdoor and indoor units - landing the shield onto the ground in the outdoor unit only.

Table 7 — Wiring Sizes 09-24

CABLE	CABLE SIZE	REMARKS
Connection Cable	14AWG	3 wire + Ground 1 $\phi$ 208/230 V (Stranded wire is recommended)

## SIZES 36-58 RECOMMENDED CONNECTION METHOD FOR POWER AND COMMUNICATION WIRING

**Power and Communication Wiring:** The main power is supplied to the outdoor unit. The field supplied power wiring from the outdoor unit to the indoor unit consists of three (3) wires and provides the power for the indoor unit. Two wires are high voltage AC power and one is a ground wire. To minimize voltage drop, the factory recommended wire size is 14/2 stranded with a ground.

**Communication Wiring:** A separate shielded stranded copper conductor only, with a 600 volt rating and double insulated copper wire, must be used as the communication wire from the outdoor unit to the indoor unit.

Please use a separate shielded 16GA stranded control wire.

Table 8 — Wiring Sizes 36-58

CABLE	CABLE SIZE	REMARKS
Power Connection Cable	14AWG	2 wire + Ground 1 $\phi$ 208/230 V
Communication Cable	16AWG	2 wire stranded shielded control wire



# CAUTION

## EQUIPMENT DAMAGE HAZARD

Be sure to comply with local codes while running wire from the indoor unit to the outdoor unit.

Every wire must be connected firmly. Loose wiring may cause the terminal to overheat or result in a unit malfunction. A fire hazard may also exist. Ensure all wiring is tightly connected.

No wire should touch the refrigerant tubing, compressor or any moving parts.

Disconnecting means must be provided and located within sight and readily accessible from the system.

Route the connecting cable with conduit through the hole in the conduit panel.

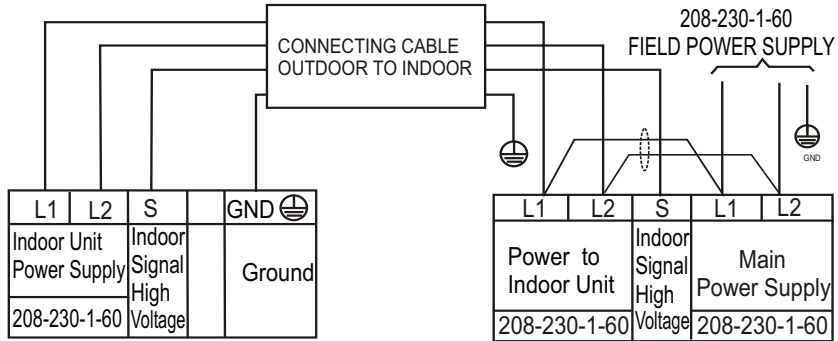
**NOTE:** The main power is supplied to the outdoor unit. When disconnecting the power of the outdoor unit, the indoor unit would lose power. A disconnect switch is not required on the Indoor unit side on the wiring between the Outdoor and Indoor unit. A 3 pole disconnect may be used for extra protection between the Indoor and Outdoor Unit.

# ELECTRICAL DATA

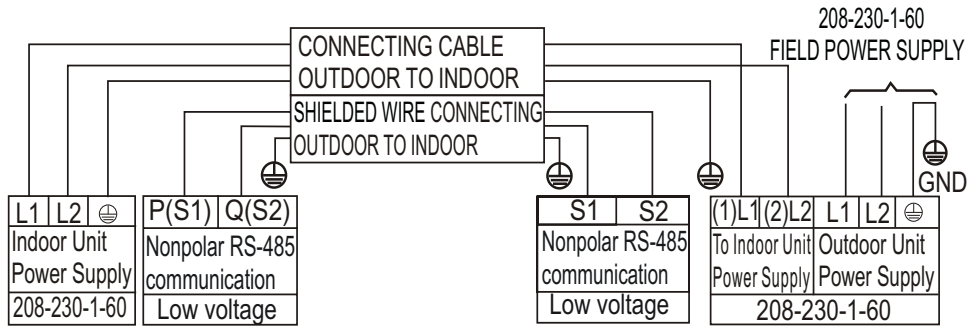
**Table 9 — Electrical Data**

UNIT SIZE	V-PH-HZ	INDOOR FAN			MAX FUSE CB AMP
		FLA	HP	W	
09	208-230/1/60	1.11	0.18	130	Refer to outdoor unit installation instructions – Indoor unit powered by the outdoor unit
12		1.11	0.18	130	
18		1.2	0.27	200	
24		1.2	0.27	200	
36		2.45	0.56	420	
48		3.2	0.75	560	
58		3.65	0.952	1,000	

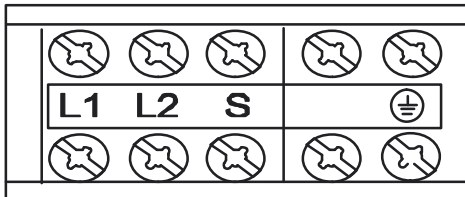
# CONNECTION DIAGRAMS



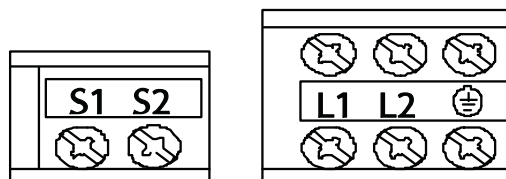
**Fig. 43 — Connection Diagrams (sizes 09K to 24K)**



**Fig. 44 — Connection Diagrams (sizes 36K and 58K)**



**Fig. 45 — Control and Power Terminal on Indoor Unit (sizes 09K to 24K)**



**Fig. 46 — Control and Power Terminals on Indoor Unit (sizes 36K to 58K)**



## Step 6 - Refrigerant Piping

**IMPORTANT: Both refrigerant lines must be insulated separately.**

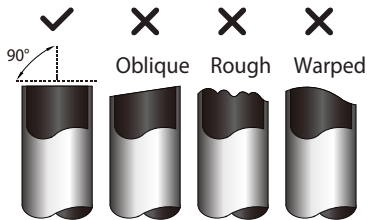
- The minimum refrigerant line length between the indoor and outdoor units is 10 ft. (3 m).
- Table 10 lists the pipe sizes for the indoor unit. Refer to the outdoor unit's installation instructions for the additional allowed piping lengths and refrigerant information.
- Refer to the outdoor unit's installation manual for details regarding the allowable pipe length and height difference.

**Table 10 — Piping Size**

		9K	12K	18K	24K	36K	48K	58K
Gas Pipe (Connection Size)	In (mm)	3/8 (9.52)	1/2 (12.7)	1/2 (12.7)	5/8 (16)	5/8 (16)	5/8 (16)	3/4 (19)
Liquid Pipe (Connection Size)	In (mm)	1/4 (6.35)	1/4 (6.35)	1/4 (6.35)	3/8 (9.52)	3/8 (9.52)	3/8 (9.52)	3/8 (9.52)

Use the following steps to connect the refrigerant piping:

1. Run interconnecting piping from the outdoor unit to the indoor unit.
2. Connect the refrigerant piping and drain line outside the indoor unit. Complete the pipe insulation at the flare connection then fasten the piping and wiring to the wall as required. Completely seal the hole in the wall.
3. Piping:
  - a. Cut the pipe, with a pipe cutter, at 90 degrees (see Fig. 47).
  - b. Remove the service connection (if provided with the unit).

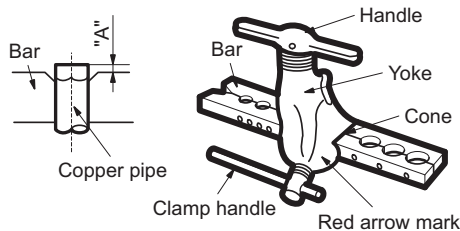


**Fig. 47 — Pipe Cutting**

- c. Remove all the burrs from the cut cross section of the pipe, avoiding any burrs from inside the tubes.
- d. Remove the flare nuts attached to the indoor and outdoor units.
- e. Install the correct size flare nut onto the tubing and make the flare connection. Refer to Table 11 for the flare nut spaces.

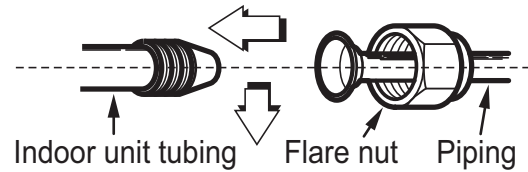
**Table 11 — Flare Nut Spacing**

OUTER DIAM. (MM)	A (MM)	
	MAX.	MIN.
Ø 1/4"(6.35)	0.05(1.3)	0.03(0.7)
Ø 3/8"(9.52)	0.06(1.6)	0.04(1.0)
Ø 1/2"(12.7)	0.07(1.8)	0.04(1.0)
Ø 5/8"(15.88)	0.09(2.2)	0.08(2.0)



**Fig. 48 — Flare Nut Spacing**

- f. Apply a small amount of refrigerant oil onto the flare connection on the tubing.
- g. Align the center of the pipes and/or the service valve.

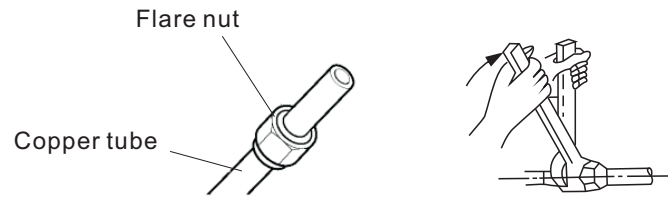


**Fig. 49 — Align Pipe Center**

- h. Connect both the liquid and gas piping to the indoor unit.
- i. Tighten the flare nut with a torque wrench (see Table 12).

**Table 12 — Tightening Torque**

BRASS FLARE SIZE	RECOMMENDED SEATING TORQUE FOR BRASS FLARE NUTS	N-M
Ø1/4	8-10 Ft. - Lbs.	10.8 to 13.6
Ø3/8	15-18 Ft. - Lbs.	20.3 to 24.4
Ø1/2	28-32 Ft. - Lbs.	38.0 to 43.4
Ø5/8	38-42 Ft. - Lbs.	51.5 to 56.9
Ø3/4	50-55 Ft. - Lbs.	68.0 to 74.6



**Fig. 50 — Tighten the flare nut**

4. Connect the drain line. Ensure there are absolutely no traps in the drain line anywhere in its length. Ensure the drain line pitches down and insulated up to the outside wall.

**NOTE:** For applications where gravity cannot be used for drainage, a condensate pump accessory is available. Consult the condensate pump installation instructions for more information.

**CAUTION**

**UNIT DAMAGE HAZARD**  
 Failure to follow this caution may result in equipment damage or improper operation.  
 Never use the system compressor as a vacuum pump.

Refrigerant tubes and the indoor coil should be evacuated using the recommended 500 Microns Deep Vacuum method. The alternate Triple Evacuation Method may be used if the procedure outlined below is followed. Review the unit's service manual for the 500 Microns Deep Vacuum or the Triple Evacuation Method.

**NOTE:** Always break a vacuum with dry nitrogen.

### Final Tubing Check

**IMPORTANT:** Ensure that certain factory tubing on both the indoor and the outdoor unit has not shifted during shipment. Ensure tubes are not rubbing against each other or any sheet metal. Pay close attention to feeder tubes, making sure wire ties on feeder tubes are secure and tight.

## WIRELESS REMOTE CONTROLLER INSTALLATION

### Mounting Bracket (if installed on the wall)

1. Use the two screws supplied with the remote controller to attach the mounting bracket to the wall in a location selected by customer and within the remote controller's operating range.
2. Install the batteries in the remote controller.
3. Place the remote controller into the remote control mounting bracket.
4. For remote controller operation, refer to the unit's owner manual.

**NOTE:** If a wireless remote controller is used, relocate the IR receiver within the line of sight of the remote location using the 6 ft. cable included. The factory location of the IR receiver is inside the remote controller box (see Fig. 51).

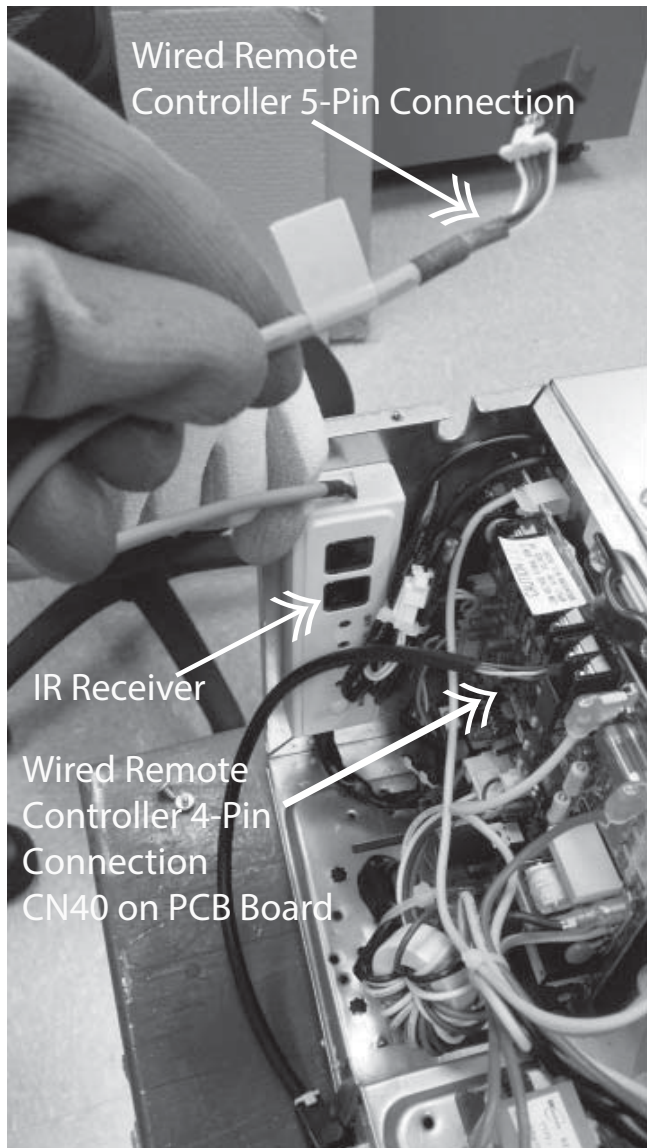


Fig. 51 — Control Box

## WIRED REMOTE CONTROLLER INSTALLATION

To connect the included wired remote controller (7 Day Programmable KSACN\*\*) to the indoor unit, the 4-pin adapter cable supplied with the controller and plug it into CN40 located on the control board.

To connect the wired remote controller (Timer Function KSACN0101AAA sold separately) to the indoor unit, use a 5-core shielded cable supplied with the wired controller to plug into the 5-pin connector from the IR receiver located in the control box (see figure 51).

For setup instructions, refer to the wired remote controller installation manual.

## START-UP

### Test Operation

After completing the gas leak and electrical safety check, perform the test operation (see Fig. 52).

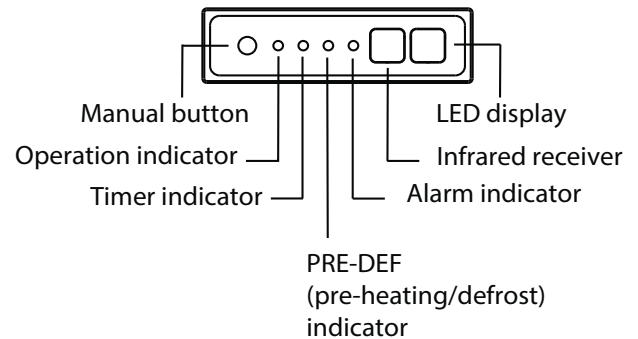


Fig. 52 — IR Receiver Display Panel

### IR Receiver Display Panel

1. Press **MANUAL** on the IR Receiver Display Panel located in the control box to begin testing.

**NOTE:** A protection feature prevents the system from starting for approximately 3 to 4 minutes.

2. Push **MODE**, select **COOLING**, **HEATING**, and **FAN** mode to verify that all the functions work as designed.
3. To run the test using the **MANUAL** option on the indoor unit:
  - a. Open the front panel of the indoor unit;
  - b. Press **MANUAL** once to energize the unit.

The set conditions of the manual operation are as follows:

  - Preset the set point: 76°F (24°C)
  - Fan speed: **AUTO**
  - Discharge the air direction: Pre-set position based on an operation in the **COOL** or **HEAT** mode.

Set the **MANUAL** option to **OFF** (by pushing it twice again) after completing the test.

## Step 7 - Setting Static Pressure or Automatic Airflow

The indoor ducted units can be programmed for different static pressures settings or airflows and the factory default setting is SP1. Use the following steps to set the static pressure or **Automatic Airflow** using the Wired Remote Controller or the Wireless Remote Controller according to the installation conditions.

### WHEN USING THE KSACN\*\* WIRED CONTROLLER:

- The external static pressure can be manually changed to the fan curves SP1, SP2, SP3, SP4.
- Use the Automatic Airflow “AF” Adjustment function to automatically identify the static pressure and regulate the airflow amount.

Follow these instructions to configure:

1. Ensure the test run is done with a dry coil. If the coil is not dry, run the unit for 2 hours in the **FAN ONLY** mode to dry the coil.
2. Check that both the power supply wiring and the duct installation have been completed. Check that dampers are properly positioned. Check that the air filter is properly attached to the air inlet side passage of the unit.
3. If there is more than one air inlet and/or outlet, adjust the dampers so that the airflow rate of each air inlet and outlet conforms to the designed airflow rate. Ensure the unit is in **FAN ONLY** mode. Press and set the **Airflow Adjustment “AF”** on the remote controller to adjust the airflow rate from **H** to **L**. Turn the indoor unit **OFF** with the Wired Controller.
4. Set the parameters for airflow adjustment. When the system is **OFF**, perform the following steps:
  - a. Press and hold **COPY** for approximately 4 seconds
  - b. Press “+” or “-” to scroll through the menu and make a selection, either **SP** or **AF**.

**NOTE:** T1, T2, T2b, T3, T4 are sub-menus for thermistors. DO NOT select to set the external static pressure.

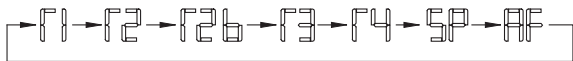


Fig. 53 — Wired Controller Menu Selection

1. If setting the external static pressure manually, select **SP** and press **CONFIRM**. Select the **SP** number (SP1, SP2, SP3, SP4 – see “FAN PERFORMANCES AT VARYING STATIC PRESSURES” on page 20 and curves (Figs. 55 through 61)). Power down the unit to lock in the selection.
2. If choosing the **AUTOMATIC AIRFLOW ADJUSTMENT** function, select **AF** and press **CONFIRM**. The system starts the fan for the airflow automatic adjustment. The **ON** indicator flashes when the fan runs during the **AUTOMATIC AIRFLOW ADJUSTMENT**. After 3 to 6 minutes, the system stops operating once the **AUTOMATIC AIRFLOW ADJUSTMENT** is complete.

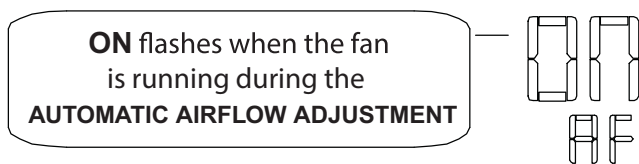


Fig. 54 — Automatic Airflow ON signal

**NOTE:** The external static pressure can also be selected using the wireless remote controller (RG57F3(B)/BGEFU1), included with the indoor unit, by pointing it toward the indoor unit’s Infrared Receiver typically located inside the control

box. Refer to the wireless remote controller service manual for further instructions.

**CAUTION**

Do not use the **AUTOMATIC AIRFLOW ADJUSTMENT** with the remote control if using booster fans, an outdoor air processing unit, or a HRV via duct.

If the ductwork or static pressure have been changed, reset the **AUTOMATIC AIRFLOW ADJUSTMENT** following steps 3 and 4.

### WHEN USING THE 24V INTERFACE KSAIC\*\*

The wireless remote controller, wired controllers KSACN\*\* and Wi-Fi kits would be disabled. Since a wired controller is required to setup the static pressure of the indoor ducted units, the 24V interface must be temporarily bypassed using the steps below:

1. Turn off the power to the unit
2. On the 24V interface, disconnect the plugs from the CN11 (to Outdoor) and CN12 (to Indoor) connections.
3. Sizes:
  - a. **For sizes 9K-24K only:** Add a jumper between the indoor S terminal to the outdoor S terminal.
  - b. **For sizes 36K-58K only:** Disconnect S1 and S2 from the 24V interface (CN8 and CN9) and splice together S1 from outdoor to S1 from indoor and S2 from outdoor to S2 from indoor.
4. Connect the Wired Controller (KSACN\*\*) and follow the external static pressure setup.
5. Once the static pressure is adjusted, disconnect the wired controller
6. Sizes:
  - a. **For sizes 9K-24K only:** Remove the S jumper from the terminal block.
  - b. **For sizes 36K-58K only:** Remove the splice and reconnect S1 and S2 back to the 24V interface accordingly.
7. Reconnect the plugs back to CN11 (to outdoor) and CN12 (to indoor) accordingly.
8. Restore power to the unit.

**NOTE:** When a system uses the 24V interface, the indoor unit’s fan speed defaults to **AUTO** with the indoor unit’s default logic.

**CAUTION**

**DUCT SIZING**

Duct work must be properly sized using the standard duct sizing program practices. Failure to do so could result in inadequate airflow to the target area. It is recommended to follow the standard practices listed on the ACCA Manual D for designing Duct Systems.

## FAN PERFORMANCES AT VARYING STATIC PRESSURES

The factory default setting is SP1. Airflows and fan curves applicable starting on production of Week 28 Year 2020 (Serial Number 2820V10001). For previous serial numbers refer to previous revision of this document.

**Table 13 — Airflow at SP1 Setting**

SYSTEM SIZE		9	12	18	24	36	48	58
High	CFM	337	397	557	955	1,233	1,576	2,481
Medium	CFM	228	295	453	689	964	1,348	1,931
Low	CFM	180	211	365	553	803	1,150	1,579

**Table 14 — 9K**

		IN.WC	0	0.02	0.04	0.08	0.1	0.12	0.14	0.16	0.2	0.24	0.292	
		9K	SP4	H	474	455	443	411	389	374	358	343	302	263
M	394			380	366	340	324	308	288	268	207			
L	386			372	359	330	314	297	277	256	188			
SP3	H		434	416	398	365	348	330	313	294	212	130		
	M		371	355	338	294	267	240	206	173				
	L		324	308	292	257	222	188	147					
SP2	H		391	372	354	327	308	289	270	247	109			
	M		300	280	261	219	186	153						
	L		267	246	226	172	151	129						
SP1	H	355	337	318	282	261	236	211	148	104				
	M	249	228	207	144									
	L	205	180	154	118									

**Table 15 — 12K**

		CFM	0	0.02	0.04	0.08	0.1	0.12	0.14	0.16	0.2	0.24	0.28
		12K	SP4	H	521	506	493	466	450	434	417	396	365
M	438			425	413	386	373	361	344	327	290	247	
L	386			373	360	330	314	297	277	257	195		
SP3	H		486	471	458	430	417	399	383	368	331	294	235
	M		395	382	369	341	325	308	289	270	210		
	L		335	319	302	268	246	224	186	147			
SP2	H		449	432	418	384	369	352	335	316	226		
	M		354	339	324	292	274	255	225	197			
	L		282	264	245	201	160	118					
SP1	H	415	397	378	348	329	311	293	273	111			
	M	311	295	278	236	206	176						
	L	235	211	189	110								

**Table 16 — 18K**

		CFM	0	0.08	0.16	0.24	0.32	0.4	0.48	0.56	0.588
		18K	SP4	H	901	848	790	727	657	582	469
M	798			745	684	617	553	468	334		
L	762			706	639	573	500	374			
SP3	H		815	755	689	616	536	414	158		
	M		733	669	606	536	453	177			
	L		690	624	557	479	364				
SP2	H		749	689	614	536	433	171			
	M		619	547	469	359	142				
	L		559	480	384	135					
SP1	H		632	557	468	340	118				
	M		534	453	351	136					
	L		462	365	148						

<300 CFM >450 CFM - Airflow below 300 CFM or above 450 cfm/ton

# FAN PERFORMANCES AT VARYING STATIC PRESSURES (CONT.)

Table 17 — 24K

			0	0.08	0.16	0.24	0.32	0.4	0.48	0.56	0.64	
24K	SP4	H	1,466	1,393	1,316	1,218	1,115	999	865	709	307	
		M	1,407	1,327	1,253	1,148	1,054	828	659	480	118	
		L	1,356	1,275	1,189	1,089	918	755	537	378	115	
	SP3	H	1,333	1,242	1,152	1,045	927	781	456	142		
		M	1,195	1,103	1,011	819	649	449	146			
		L	1,121	1,035	936	723	534	330	121			
	SP2	H	1,202	1,108	1,012	885	742	430	133			
		M	1,004	905	772	534	304	127				
		L	930	825	622	388	117					
	SP1	H	1,055	955	825	686	373	124				
		M	814	689	440	132						
		L	722	553	267	118						

Table 18 — 36K

			0	0.08	0.16	0.24	0.32	0.4	0.48	0.56	0.64	0.72	0.8
36K	SP4	H	1,790	1,753	1,712	1,678	1,637	1,602	1,552	1,429	1,271	1,074	670
		M	1,786	1,722	1,675	1,640	1,545	1,431	1,298	1,144	773		
		L	1,779	1,723	1,675	1,591	1,486	1,347	1,200	1,009	606		
	SP3	H	1,770	1,768	1,723	1,609	1,488	1,358	1,213	1,014	615		
		M	1,705	1,607	1,503	1,387	1,260	1,095	888	414	121		
		L	1,650	1,543	1,433	1,312	1,166	989	597	117			
	SP2	H	1,658	1,553	1,434	1,304	1,161	975	593				
		M	1,424	1,297	1,171	1,005	793	332	115				
		L	1,333	1,200	1,058	879	491	137					
	SP1	H	1,339	1,233	1,108	945	727	161					
		M	1,119	964	770	372	127						
		L	980	803	534	125							

Table 19 — 48K

			0	0.08	0.16	0.24	0.32	0.4	0.48	0.56	0.64	0.72	0.8	0.88
48K	SP4	H									1,813	1,559	1,330	1,032
		M	2,042	2,008	1,984	1,955	2,002	1,961	1,842	1,665	1,407	983	580	
		L	2,032	2,012	1,988	1,956	1,996	1,829	1,682	1,416	1,167	592		
	SP3	H		2,273	2,091	2,005	1,911	1,835	1,742	1,490	1,205	918		
		M	2,066	1,992	1,898	1,884	1,736	1,587	1,287	1,015	616			
		L	2,002	1,916	1,833	1,783	1,634	1,467	1,147	792	414			
	SP2	H	2,014	1,904	1,848	1,688	1,593	1,335	1,055	762				
		M	1,759	1,689	1,624	1,465	1,267	893	241					
		L	1,656	1,617	1,469	1,289	988	642						
	SP1	H	1,701	1,576	1,544	1,369	1,046	706						
		M	1,436	1,348	1,142	812								
		L	1,307	1,150	922	483								

Table 20 — 58K

			0	0.08	0.16	0.24	0.32	0.4	0.48	0.56	0.64	0.72	0.8
58K	SP4	H					2,931	2,805	2,672	2,514	2,335	2,178	2,014
		M	2,941	2,843	2,725	2,599	2,452	2,292	2,097	1,911	1,700	1,474	1,266
		L	2,593	2,470	2,321	2,178	2,007	1,829	1,682	1,416	1,167	960	769
	SP3	H			2,869	2,745	2,609	2,459	2,285	2,098	1,913	1,731	1,486
		M	2,660	2,543	2,397	2,242	2,057	1,861	1,677	1,410	1,075	738	437
		L	2,440	2,312	2,147	1,965	1,758	1,539	1,314	917	663	248	
	SP2	H	2,815	2,666	2,579	2,431	2,273	2,078	1,917	1,697	1,449	1,178	720
		M	2,364	2,230	2,053	1,860	1,648	1,403	1,129	763	548		
		L	2,041	1,872	1,669	1,427	1,164	756	522	295			
	SP1	H	2,604	2,481	2,339	2,177	1,984	1,780	1,588	1,284	942	644	295
		M	2,095	1,931	1,730	1,500	1,245	865	610	366	194		
		L	1,772	1,579	1,328	1,027	625	362	168				

<300 CFM >450 CFM - Airflow below 300 CFM or above 450 cfm/ton

# FAN PERFORMANCES AT VARYING STATIC PRESSURES (CONT.)

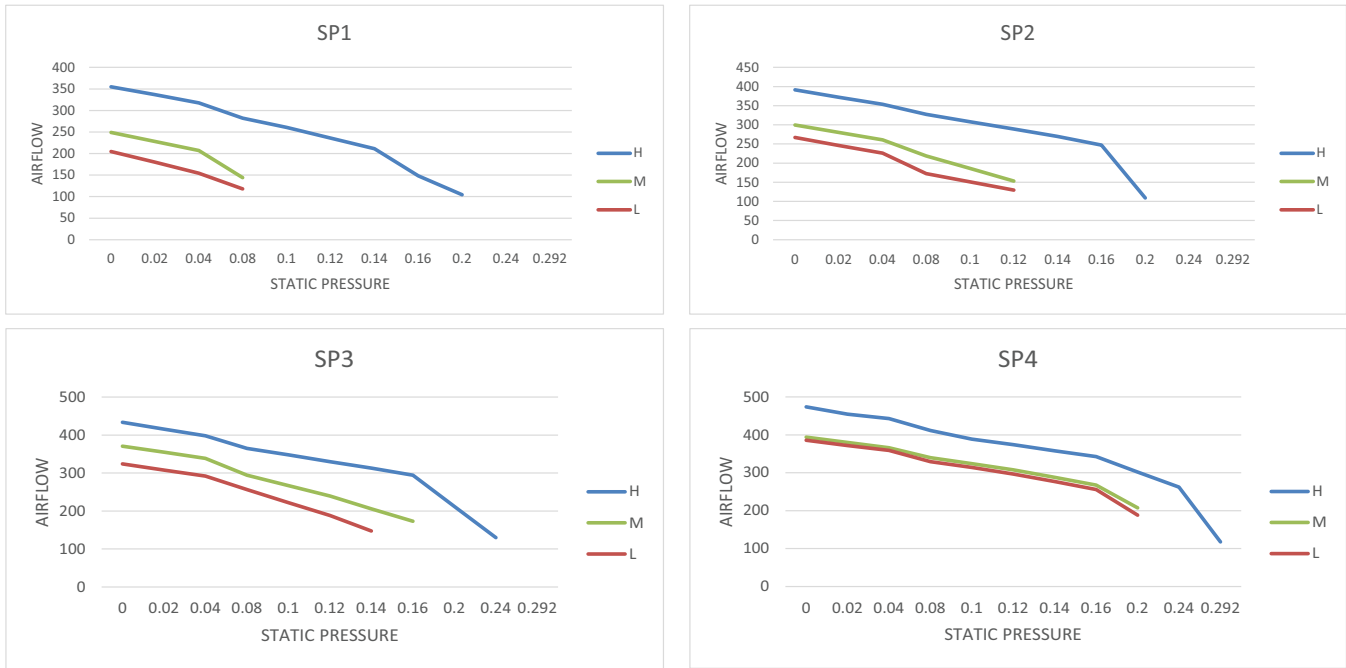


Fig. 55 — Fan Performance - Size 9

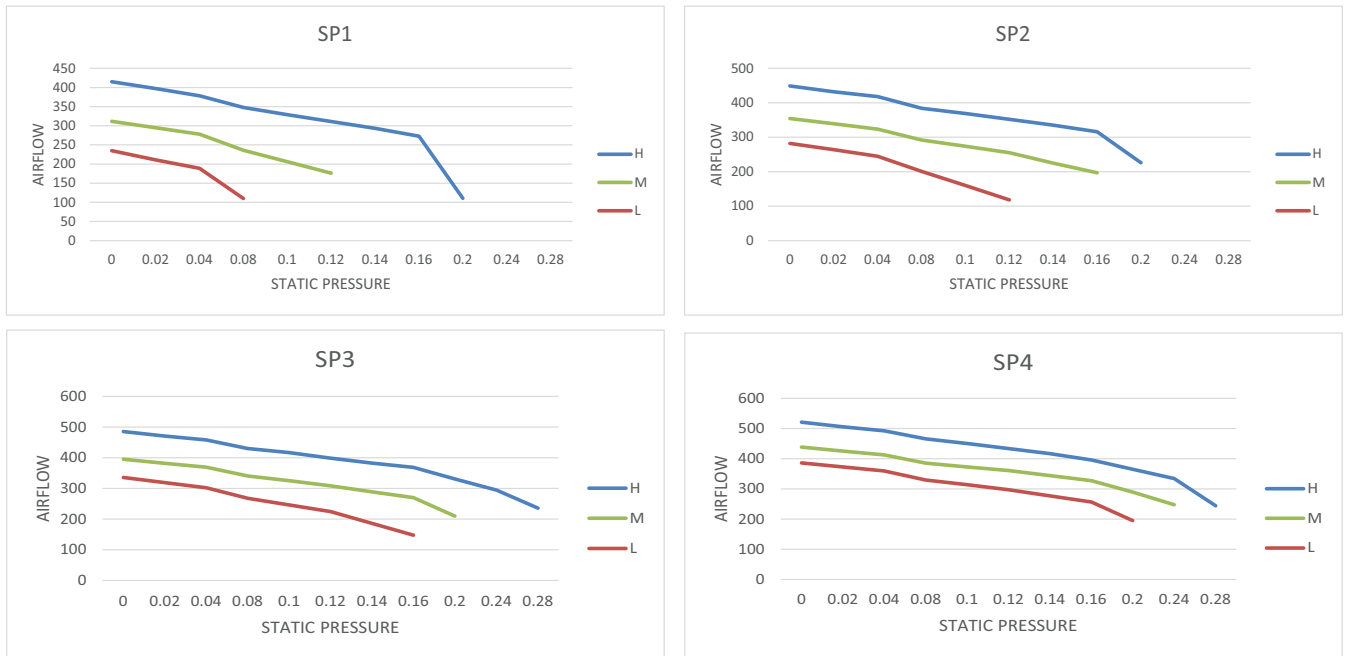


Fig. 56 — Fan Performance - Size 12

# FAN PERFORMANCES AT VARYING STATIC PRESSURES (CONT.)

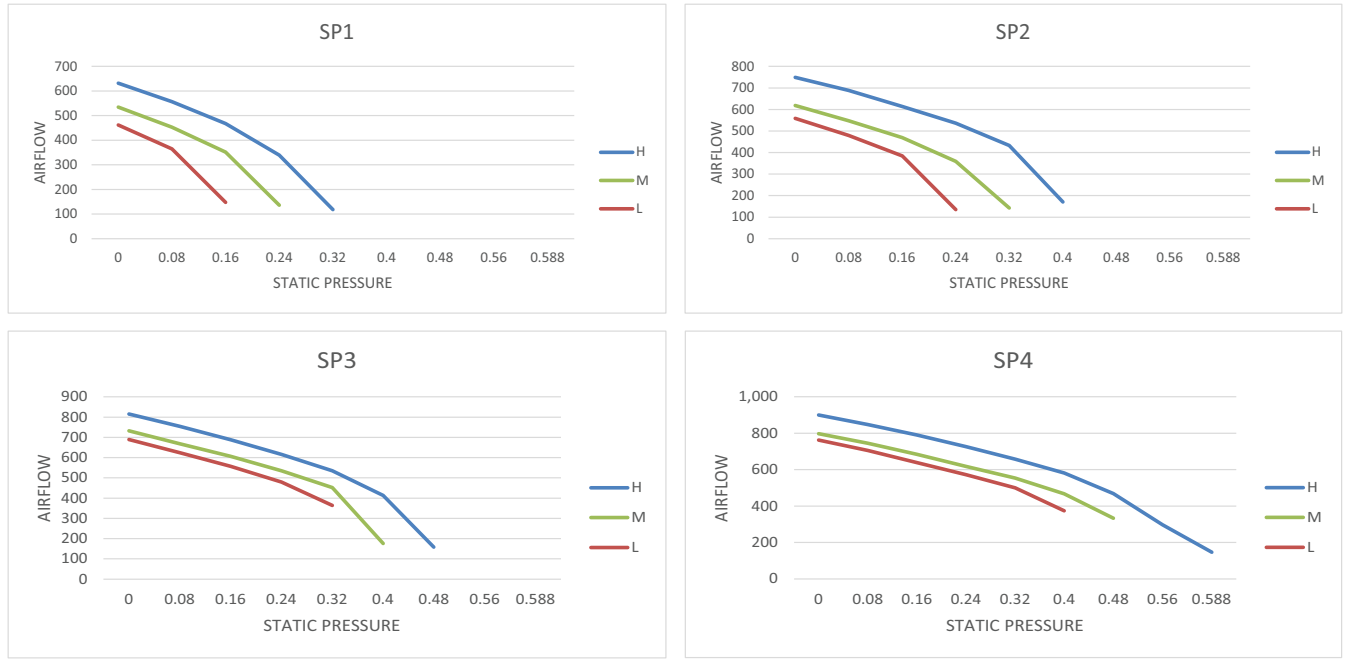


Fig. 57 — Fan Performance - Size 18

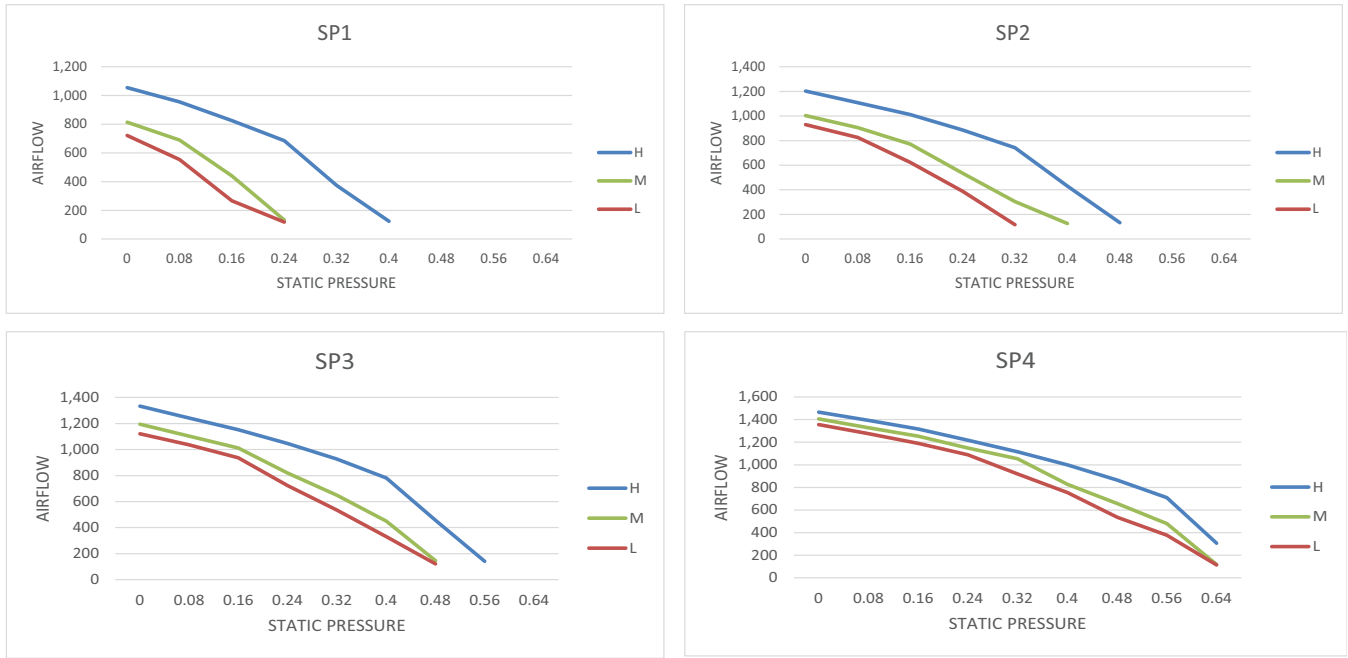


Fig. 58 — Fan Performance - Size 24

# FAN PERFORMANCES AT VARYING STATIC PRESSURES (CONT.)

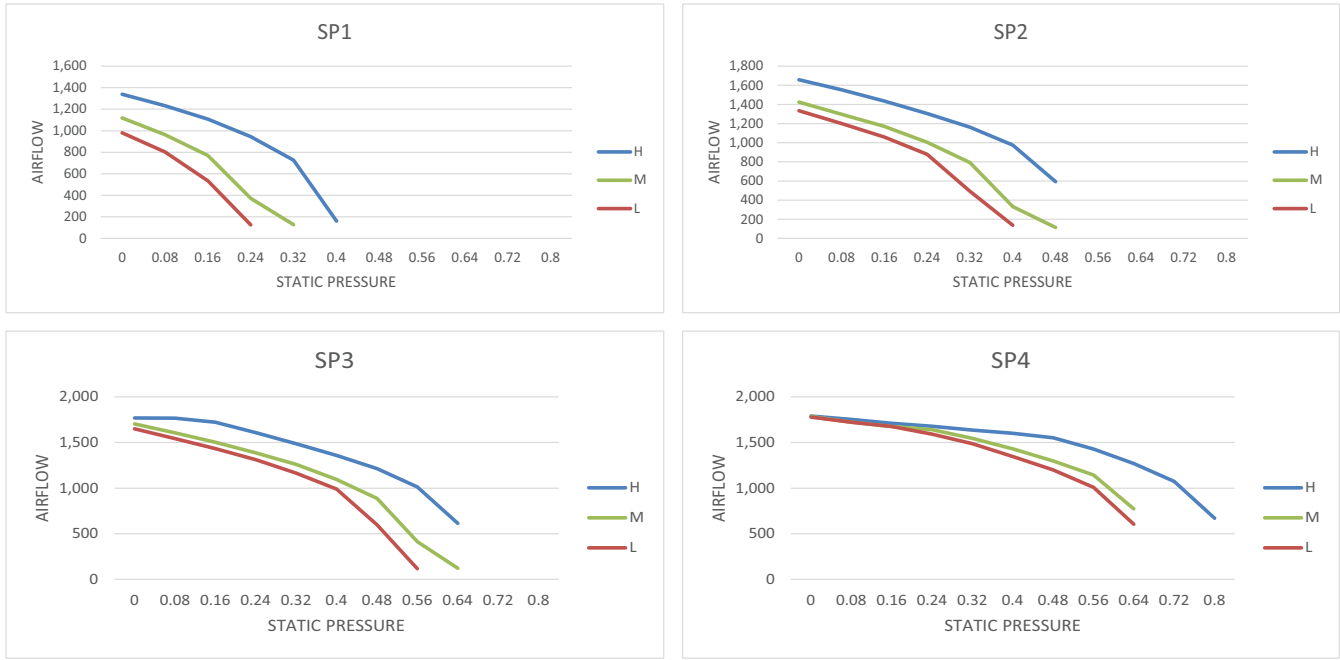


Fig. 59 — Fan Performance - Size 36

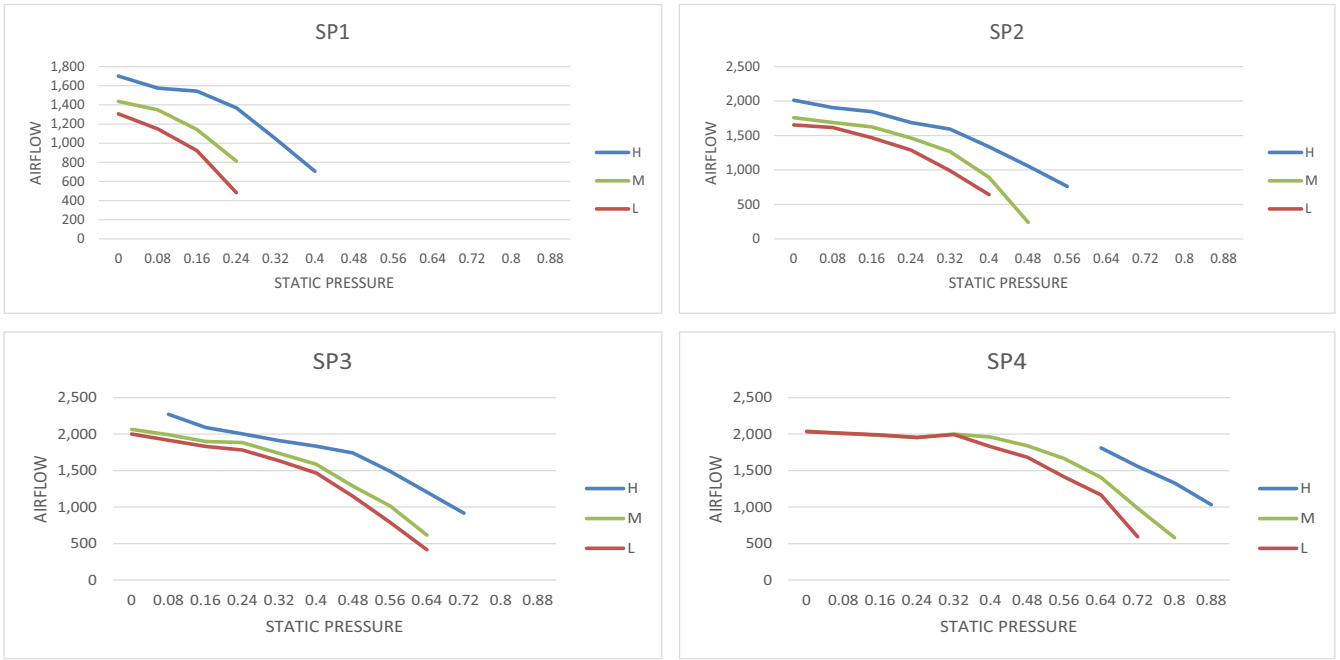


Fig. 60 — Fan Performance - Size 48



# FAN PERFORMANCES AT VARYING STATIC PRESSURES (CONT.)

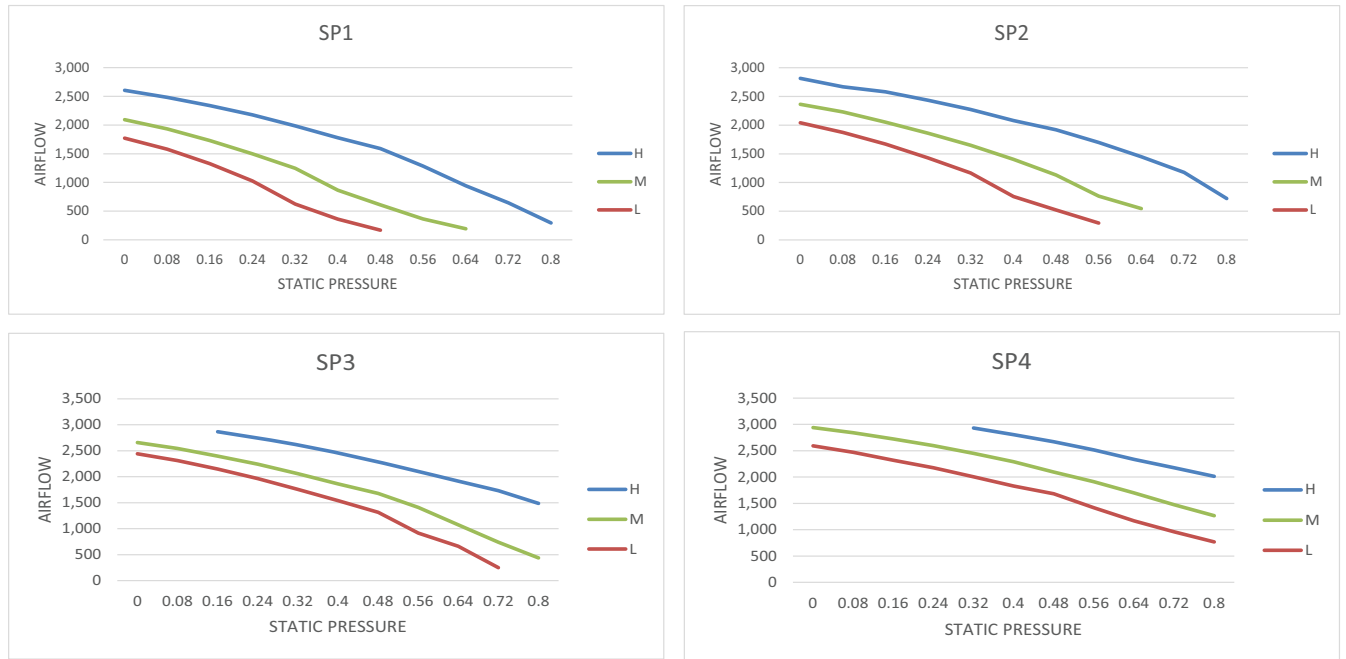


Fig. 61 — Fan Performance - Size 58

## SYSTEM CHECKS

1. Conceal the tubing where possible.
2. Ensure the drain tube slopes downward along its entire length.
3. Ensure all tubing and connections are properly insulated.
4. Fasten the tubes to the outside wall, when possible.
5. Seal the hole through which the cables and tubing pass.

## INDOOR UNIT

1. Do all the remote controller buttons function properly?
2. Do the display panel lights work properly?
3. Does the air deflection louver function properly?
4. Does the drain work?

Explain the following items to customer (with the aid of the owner's manual):

1. How to turn the system **ON** and **OFF**;
2. How to select **COOLING**, **HEATING** and other the operating modes;
3. How to set a desired temperature;
4. How to set the timer to automatically start and stop the system's operation;
5. How to control all the other features of the remote controller and display panel.
6. How to remove and clean the air filter.
7. How to set the air deflection louver.
8. Unit care and maintenance.

Present the owner's manual and installation instructions to the customer.

## CARE AND MAINTENANCE

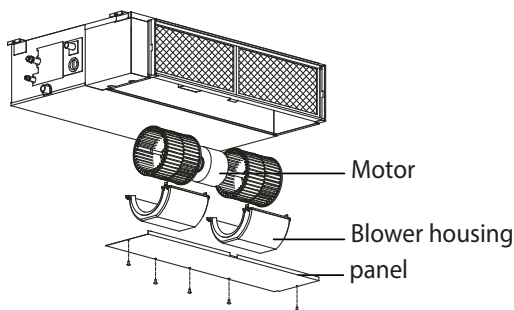
To continue high performance and minimize possible equipment failure, it is essential that periodic maintenance be performed on this equipment. Consult your local dealer as to the proper frequency of maintenance contract.

The ability to properly perform maintenance on this equipment requires certain mechanical skills and tools. If you do not possess these, contact your dealer for maintenance. The only consumer service recommended or required is filter replacement or cleaning on a monthly basis.

## FAN MOTOR MAINTENANCE

### Sizes 09K-48K:

1. Remove the panel.
2. Remove the blower housing.
3. Remove the motor.

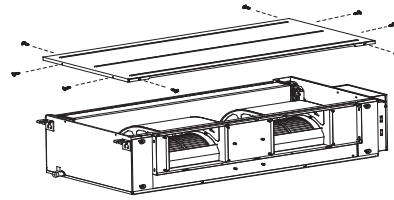


**Fig. 62 — Motor Maintenance sizes 09K-48K**

### Size 58K:

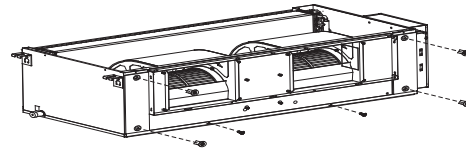
Two methods available:

1. Remove the front side plate from the top.
  - a. Remove the top cover.



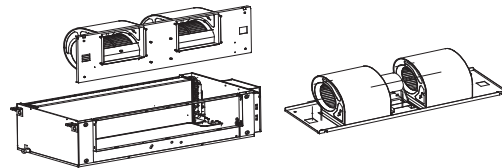
**Fig. 63 — Remove the top cover**

- b. Loosen the four bolts and two screws that secure the front side plate.



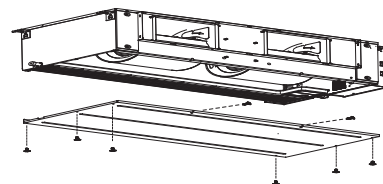
**Fig. 64 — Loosen the four bolts and two screws**

- c. Remove the motor cord, take off the front side plate and repair the motor.



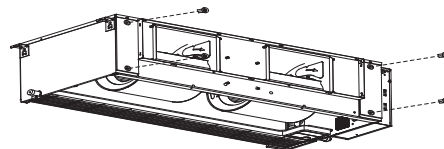
**Fig. 65 — Remove the motor cord**

2. Remove the front side plate from the bottom.
  - a. Remove the bottom base.



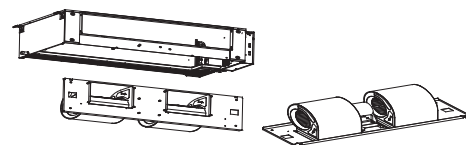
**Fig. 66 — Remove the bottom base**

- b. Loosen the four bolts and two screws that secure the front side plate. Be careful, the front side plate may fall down.



**Fig. 67 — Loosen the four bolts**

- c. Remove the motor cord, take off the front side plate and repair the motor.



**Fig. 68 — Remove the motor cord**

## TROUBLESHOOTING

For ease of service, the systems are equipped with diagnostic code display LEDs on both the indoor and outdoor units. The outdoor diagnostic display consists of two LEDs (red and green) on the outdoor unit board and is limited to a few errors. The indoor diagnostic display is a combination of flashing LEDs on the display panel or the front of the unit. If possible, always check the diagnostic codes displayed on the indoor unit first before consulting a service technician.

The diagnostic codes, displayed in the indoor and outdoor units, are listed in Table 21.

### INDOOR UNIT DIAGNOSTIC GUIDES

Table 21 — Indoor Unit Diagnostic Guides

OPERATION LAMP	TIMER LAMP	DISPLAY	LED STATUS
★ 1 time	X	E0	Indoor unit EEPROM parameter error
★ 2 times	X	E1	Indoor / outdoor units communication error
★ 8 times	X	EE	Water level alarm malfunction
★ 4 times	X	E3	Indoor fan speed is out of control
★ 5 times	X	E4	Indoor room temperature sensor T1 open circuit or short circuit
★ 6 times	X	E5	Evaporator coil temperature sensor T2 open circuit or short circuit
★ 9 times	X	E8	Dual indoor unit (twin model only) communication malfunction
★ 10 times	X	E9	Other twin model malfunction
★ 7 times	X	EC	Refrigerant leakage detection
★ 1 time	O	F0	Overload Protection
★ 11 times	O	Fa	Indoor unit communication malfunction
★ 2 times	O	F1	Outdoor ambient temperature sensor T4 open circuit or short circuit
★ 3 times	O	F2	Condenser coil temperature sensor T3 open circuit or short circuit
★ 4 times	O	F3	Compressor discharge temperature sensor T5 open circuit or short circuit
★ 5 times	O	F4	Outdoor unit EEPROM parameter error
★ 6 times	O	F5	Outdoor fan speed is out of control
★ 7 times	O	F6	Compressor low-pressure protection
★ 1 time	«	P0	IPM malfunction or IGBT over-strong current protection
★ 2 times	«	P1	Over voltage or over low voltage protection
★ 3 times	«	P2	High temperature protection of compressor top diagnosis and solution (9K,12K models only)
★ 4 times	«	P3	Outdoor low temperature protection
★ 5 times	«	P4	Inverter compressor drive error
★ 7 times	«	P6	Compressor low-pressure protection
★ 8 times	«	P7	Outdoor IGBT sensor error

**O (light) X (off) «(flash)**

For additional diagnostic information, refer to the indoor unit service manual.

## **ADVANCED SERVICE AND INSTALLATION FUNCTIONS**

Refer to the Wireless Remote Controller service manual for access to advanced functions such as:

- Auto-Start
- Temperature Compensation
- Filter Reminder
- Indoor Fan Motor Speed Control (after set temperature is reached)
- Lowest or Highest Temperature Setting
- Static Pressure Setting

All changes should be performed **ONLY** by authorized professionals.