

**50ZHC
Single-Packaged Heat Pump System
With Puron® (R-410A) Refrigerant
Single Phase
2 to 5 Nominal Tons (Sizes 024-060)**



Installation Instructions

IMPORTANT: Effective January 1, 2015, all split system and packaged air conditioners must be installed pursuant to applicable regional efficiency standards issued by the Department of Energy.

NOTE: Read the entire instruction manual before starting the installation.

NOTE: Installer: Make sure the Owner's Manual and Service Instructions are left with the unit after installation.

TABLE OF CONTENTS

| | PAGE |
|---|-------|
| SAFETY CONSIDERATIONS | 2 |
| INTRODUCTION | 2 |
| RECEIVING AND INSTALLATION | 2-10 |
| Check Equipment | 2 |
| Identify Unit | 2 |
| Inspect Shipment | 2 |
| Provide Unit Support | 2 |
| Slab Mount | 2 |
| Ground Mount | 2 |
| Provide Clearances | 3 |
| Place Unit | 3 |
| Select and Install Ductwork | 3 |
| Installing factory-supplied duct flanges | 3 |
| Configuring Units for Downflow (Vertical) Discharge | 9 |
| Connect Condensate Drain | 9 |
| Install Electrical Connections | 9 |
| High-Voltage Connections | 9 |
| Routing Power Leads Into Unit | 9 |
| Connecting Ground Lead to Unit Ground | 10 |
| Routing Control Power Wires | 10 |
| Accessory Electric Heat Wiring | 10 |
| PRE-START-UP | 10 |
| START-UP | 11-14 |
| Check for Refrigerant Leaks | 11 |
| Start-Up Cooling and Make Adjustments | 11 |
| Checking Cooling and Heating Control Operation | 11 |
| Refrigerant Charge | 11 |
| No Charge | 11 |
| Low Charge Cooling | 11 |
| Heating Mode Charge | 12 |
| Indoor Airflow and Airflow Adjustments | 14 |
| Sequence of Operation | 14 |
| Fan Operation | 14 |
| Cooling Operation | 14 |
| Heating Operation | 14 |
| Continuous Fan | 14 |

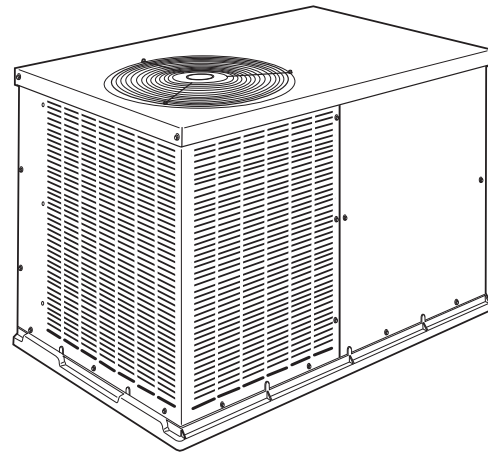

50ZHC 024-048

A05165

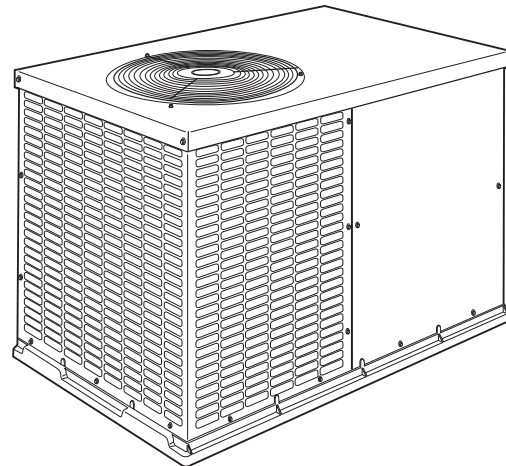

50ZHC 060

A150067

Fig. 1 - 50ZHC

Certified to leak 2% or less of nominal air conditioning CFM delivered when pressurized to 1-in. W.C. with all present air inlets, air outlets, and condensate drain port(s) sealed.

| | |
|---|-------|
| Defrost | 14 |
| Electric Resistance Heating | 14 |
| MAINTENANCE | 18-21 |
| Air Filter | 18 |
| Unit Top Removal | 18 |
| Indoor Blower and Motor | 19 |
| Outdoor Coil, Indoor Coil, and Condensate Drain Pan | 19 |
| Outdoor Fan Adjustment | 19 |
| Electrical Controls and Wiring | 20 |
| Refrigerant Circuit | 20 |

Indoor Airflow 20
 Metering Devices 20
 High Flow Valves 20
 High Pressure Switch 20
 Loss of Charge Switch 20
 Puron® (R-410A) Compressor 20
 Refrigerant 21
 Compressor Oil 21
 Servicing Systems on Roofs with Synthetic Materials 21
 Synthetic Roof Precautionary Procedure 21
 Liquid Line Filter Drier 21
 Puron® (R-410A) Refrigerant Charging 21
 TROUBLESHOOTING 21
 START-UP CHECKLIST 21

SAFETY CONSIDERATIONS

Installation and servicing of this equipment can be hazardous due to mechanical and electrical components. Only trained and qualified personnel should install, repair, or service this equipment.

Untrained personnel can perform basic maintenance functions such as cleaning and replacing air filters. All other operations must be performed by trained service personnel. When working on this equipment, observe precautions in the literature, on tags, and on labels attached to or shipped with the unit and other safety precautions that may apply.

Follow all safety codes. Wear safety glasses, protective clothing, and work gloves. Use quenching cloth for brazing operations. Have fire extinguisher available. Read these instructions thoroughly and follow all warnings or cautions included in literature and attached to the unit. Consult local building codes, the current editions of the National Electrical Code (NEC) NFPA 70 and NFPA 90B-Installation Warm Air Heating and A/C Systems (Residential). In Canada refer to the current editions of the Canadian Electrical Code CSA C22.1.

Recognize safety information. This is the safety-alert symbol . When you see this symbol on the unit and in instructions or manuals, be alert to the potential for personal injury. Understand these signal words: DANGER, WARNING, and CAUTION. These words are used with the safety-alert symbol. DANGER identifies the most serious hazards which **will** result in severe personal injury or death. WARNING signifies hazards which **could** result in personal injury or death. CAUTION is used to identify unsafe practices which **may** result in minor personal injury or product and property damage. NOTE is used to highlight suggestions which **will** result in enhanced installation, reliability, or operation.

 **WARNING**

ELECTRICAL SHOCK HAZARD

Failure to follow this warning could result in personal injury or death.

Before installing or servicing system, always turn off main power to system and install lockout tag. There may be more than one disconnect switch. Turn off accessory heater power switch if applicable.

 **CAUTION**

CUT HAZARD

Failure to follow this caution may result in personal injury. Sheet metal parts may have sharp edges or burrs. Use care and wear appropriate protective clothing, safety glasses and gloves when handling parts and servicing.

 **WARNING**

PERSONAL INJURY AND ENVIRONMENTAL HAZARD

Failure to relieve system pressure could result in personal injury and/or death.

1. Relieve pressure and recover all refrigerant before servicing existing equipment, and before final unit disposal. Use all service ports and open all flow-control devices, including solenoid valves.
2. Federal regulations require that you do not vent refrigerant into the atmosphere. Recover during system repair or final unit disposal.

INTRODUCTION

This packaged heat pump is fully self-contained and designed for outdoor installation (See Fig. 1). Standard units are shipped in a horizontal-discharge configuration for installation on a ground-level slab or directly on the ground if local codes permit. Standard units can be converted to downflow (vertical) discharge configurations for rooftop applications with a field supplied plenum.

RECEIVING AND INSTALLATION

Step 1 — Check Equipment

IDENTIFY UNIT

The unit model number and serial number are printed on the unit informative plate. Check this information against shipping papers.

INSPECT SHIPMENT

Inspect for shipping damage while unit is still on shipping pallet. If unit appears to be damaged or is torn loose from its anchorage, have it examined by transportation inspectors before removal. Forward claim papers directly to transportation company. Manufacturer is not responsible for any damage incurred in transit. Check all items against shipping list. Immediately notify the nearest equipment distribution office if any item is missing. To prevent loss or damage, leave all parts in original packages until installation.

Step 2 — Provide Unit Support

For hurricane tie downs, contact distributor for details and PE (Professional Engineering) Certificate, if required.

SLAB MOUNT

Place the unit on a solid, level concrete pad that is a minimum of 4 in. (102 mm) thick with 2 in. (51 mm) above grade. The slab should extend approximately 2 in. (51 mm) beyond the casing on all 4 sides of the unit. Do not secure the unit to the slab *except* when required by local codes.

A 6-in. (152 mm) wide gravel apron should be used around the flat surface to prevent airflow blockage by grass or shrubs. The unit should be level within 1/4 in. (6 mm). This is necessary for the unit drain to function properly.

GROUND MOUNT

The unit may be installed either on a slab or placed directly on the ground if local codes permit. Place the unit on level ground prepared with gravel for condensate discharge.

Step 3 — Provide Clearances

The required minimum service clearances are shown in Fig. 4-6. Adequate ventilation and outdoor air must be provided.

The outdoor fan draws air through the outdoor coil and discharges it through the top fan grille. Be sure that the fan discharge does not recirculate to the outdoor coil. Do not locate the unit in either a corner or under an overhead obstruction. The minimum clearance under a partial overhang (such as a normal house overhang) is 48 in. (1219 mm) above the unit top. The maximum horizontal extension of a partial overhang must not exceed 48 in. (1219 mm).

IMPORTANT: Do not restrict outdoor airflow. An air restriction at either the outdoor-air inlet or the fan discharge may be detrimental to compressor life.

Do not place the unit where water, ice, or snow from an overhang or roof will damage or flood the unit. Do not install the unit on carpeting or other combustible materials. Slab-mounted units should be at least 4 in. (102 mm) above the highest expected water and runoff levels. Do not use unit if it has been under water.

Step 4 — Place Unit

Unit can be moved with the rigging holds provided in the unit base. Refer to Table 1 for operating weights. Use extreme caution to prevent damage when moving the unit. Unit must remain in an upright position during all moving operations. The unit must be level with in 1/4 in. (6 mm) for proper condensate drainage; the ground-level pad must be level before setting the unit in place. When a field-fabricated support is used, be sure that the support is level and that it properly supports the unit.

Step 5 — Select and Install Ductwork

The design and installation of the duct system must be in accordance with the standards of the NFPA for installation of non-residence type air conditioning and ventilating systems, NFPA 90A or residence type, NFPA 90B and/or local codes and ordinances.

Select and size ductwork, supply-air registers, and return air grilles according to ASHRAE (American Society of Heating, Refrigeration, and Air Conditioning Engineers) recommendations.

Use the duct flanges provided on the supply- and return-air openings on the side of the unit. See Fig. 4-6 for connection sizes and locations. **The 14-in. (356 mm) round or 14 x 20 in. (356 x 508 mm) rectangular duct collars are shipped inside the unit attached to the base pan in the indoor blower compartment. They are field-installed and must be removed from the indoor blower compartment prior to start-up, even if they are not used for installation. If a corrugated shipping block is used under the blower housing, remove and discard the block and label.**

When designing and installing ductwork, consider the following:

⚠ CAUTION

UNIT DAMAGE HAZARD

Failure to follow this caution may result in damage to unit components.

When connecting ductwork to units, do not drill deeper than 3/4 in. (19 mm) in shaded area shown in Fig. 2 or coil may be damaged.

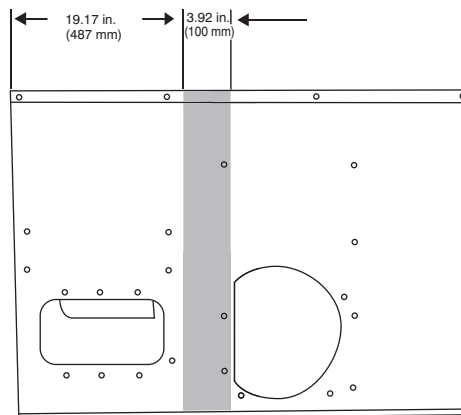

A10021

Fig. 2 - Area Not to be Drilled More Than 3/4-in. (19 mm) Deep

1. All units should have field-supplied filters or accessory filter rack installed in the return-air side of the unit. Recommended sizes for filters are shown in Table 1.
2. Avoid abrupt duct size increases and reductions. Abrupt change in duct size adversely affects air performance.

IMPORTANT: Use flexible connectors between ductwork and unit to prevent transmission of vibration. Use suitable gaskets to ensure weather tight and airtight seal. When electric heat is installed, use fireproof canvas (or similar heat resistant material) connector between ductwork and unit discharge connection. If flexible duct is used, insert a sheet metal sleeve inside duct. Heat resistant duct connector (or sheet metal sleeve) must extend 24-in. (610 mm) from electric heater element.

3. Size ductwork for cooling air quantity (cfm). The minimum air quantity for proper electric heater operation is listed in Table 2. Heater limit switches may trip at air quantities below those recommended.
4. Seal, insulate, and weatherproof all external ductwork. Seal, insulate and cover with a vapor barrier all ductwork passing through conditioned spaces. Follow latest Sheet Metal and Air Conditioning Contractors National Association (SMACNA) and Air Conditioning Contractors Association (ACCA) minimum installation standards for residential heating and air conditioning systems.
5. Secure all ducts to building structure. Flash, weatherproof, and vibration-isolate duct openings in wall or roof according to good construction practices.

Fig. 7 shows a typical duct system with unit installed.

Installing factory-supplied duct flanges:

For 24, 30, and 36 sizes:

- Two round 14-in. (356 mm) duct collars are factory supplied.
- Line up the 6 holes in the duct collar with the pre-drilled holes in the side panel.
- Fasten duct collar to side panel using field-supplied screws.

For 42, 48 and 60 sizes (See Fig. 3):

- One round 14-in. (356 mm) duct collar for the supply air connections and two "L" brackets for the 14-in. x 20-in. (356 x 508 mm) return air connection are factory-supplied.
- Line up the 6 holes in the supply duct collar with the pre-drilled holes in the side panel. Fasten duct collar to side panel using field-supplied screws.
- For the return, remove the 4 screws on the left side of the return and install one of the "L" flanges on the left side by replacing the 4 screws. Using the 2 dimples below the return, align the

bottom of the “L” flange with the two dimples and attach using field-supplied thread-cutting screws.

For the second “L” flange, align flange with the three dimples to the right of the return and the two dimples above the return and attach using field-supplied thread-cutting screws.

NOTE: The factory-installed screws to the right of the return should not be removed in this process.

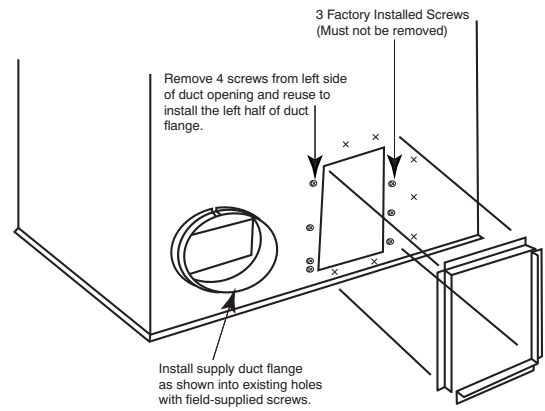

X = Factory dimples for duct flange attachment.

A10081

Fig. 3 - Installing Factory-Supplied Duct Flanges

| UNIT | ELECTRICAL CHARACTERISTICS | UNIT WT. | | | UNIT HEIGHT | | | CENTER OF GRAVITY IN [MM] | | |
|---------------|----------------------------|----------|-----|--------------|-------------|----------|----------|---------------------------|----------|----------|
| | | LBS. | KG. | A | X | Y | Z | | | |
| 50ZHC024---30 | 208/230-1-60 | 253 | 115 | 30-1/8 [765] | 14 [356] | 19 [483] | 14 [356] | 19 [483] | 14 [356] | 16 [406] |
| 50ZHC030---30 | 208/230-1-60 | 283 | 128 | 34-1/8 [867] | 14 [356] | 19 [483] | 14 [356] | 19 [483] | 16 [406] | 16 [406] |
| 50ZHC036---30 | 208/230-1-60 | 285 | 130 | 34-1/8 [867] | 14 [356] | 19 [483] | 14 [356] | 19 [483] | 16 [406] | 16 [406] |

REQUIRED CLEARANCES TO COMBUSTIBLE MATL.

| | INCHES [MM] |
|--|-------------|
| TOP OF UNIT..... | 0 |
| BOTTOM OF UNIT..... | 0 |
| SIDE OF UNIT WITH DUCT OPENINGS..... | 0 |
| SIDE OF UNIT OPPOSITE DUCT OPENINGS..... | 0 |

NEC. REQUIRED CLEARANCES

| | INCHES [MM] |
|---|-------------|
| BETWEEN UNITS, POWER ENTRY SIDE..... | 42.0 [1067] |
| UNIT AND UNGROUNDED SURFACES, POWER ENTRY SIDE..... | 36.0 [914] |
| UNIT AND BLOCK OR CONCRETE WALLS AND OTHER GROUNDED SURFACES, POWER ENTRY SIDE..... | 42.0 [1067] |

REQUIRED CLEARANCE FOR SERVICING

| | INCHES [MM] |
|--|-------------|
| TOP OF UNIT..... | 36.0 [914] |
| SIDE OF UNIT OPPOSITE DUCT OPENINGS..... | 30.0 [762] |
| SIDE OF UNIT WITH POWER ENTRY (EXCEPT FOR NEC REQUIREMENTS)..... | 30.0 [762] |

NOTE: CLEARANCES MUST BE MAINTAINED TO PREVENT RECIRCULATION OF AIR FROM OUTDOOR FAN DISCHARGE. A REMOVABLE FENCE OR BARRICADE REQUIRES NO CLEARANCE.

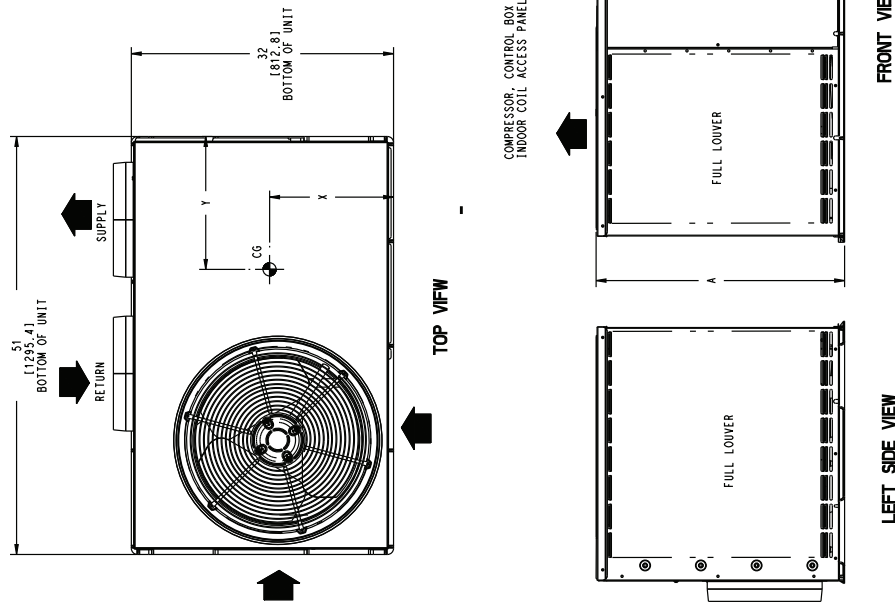

DIMENSIONS IN [] ARE IN MM

| | | |
|------------|-----|---|
| 50ZH500672 | REV | - |
|------------|-----|---|

50ZHC

Fig. 4 - Unit Base Dimensions, 024-036

50ZHC

| UNIT | ELECTRICAL CHARACTERISTICS | UNIT WT. | | | UNIT HEIGHT | | | CENTER OF GRAVITY IN [MM] | | |
|---------------|----------------------------|----------|-----|---------------|-------------|----------|--------------|---------------------------|--|--|
| | | LBS. | KG. | A | X | Y | Z | | | |
| 50ZHC042---30 | 208/230-1-60 | 339 | 154 | 42-1/8 [1070] | 14 [356] | 19 [483] | 19-3/4 [503] | | | |
| 50ZHC048---30 | 208/230-1-60 | 358 | 163 | 42-1/8 [1070] | 14 [356] | 19 [483] | 19-3/4 [503] | | | |

REQUIRED CLEARANCES TO COMBUSTIBLE MATL.

| | |
|--|-------------|
| TOP OF UNIT..... | INCHES [MM] |
| BOTTOM OF UNIT..... | 0 |
| SIDE OF UNIT WITH DUCT OPENINGS..... | 0 |
| SIDE OF UNIT OPPOSITE DUCT OPENINGS..... | 0 |

NEC. REQUIRED CLEARANCES.

| | |
|---|-------------|
| BETWEEN UNITS, POWER ENTRY SIDE..... | INCHES [MM] |
| UNIT AND UNGROUNDED SURFACES, POWER ENTRY SIDE..... | 42.0 [1067] |
| UNIT AND BLOCK OR CONCRETE WALLS AND OTHER GROUNDED SURFACES, POWER ENTRY SIDE..... | 36.0 [914] |

REQUIRED CLEARANCE FOR SERVING

| | |
|--|-------------|
| TOP OF UNIT..... | INCHES [MM] |
| SIDE OF UNIT OPPOSITE DUCT OPENINGS..... | 36.0 [914] |
| SIDE OF UNIT WITH POWER ENTRY (EXCEPT FOR NEC REQUIREMENTS)..... | 30.0 [762] |
| SIDE OF UNIT WITH POWER ENTRY (EXCEPT FOR NEC REQUIREMENTS)..... | 30.0 [762] |

NOTE: CLEARANCES MUST BE MAINTAINED TO PREVENT RECIRCULATION OF AIR FROM OUTDOOR FAN DISCHARGE. A REMOVABLE FENCE OR BARRICADE REQUIRES NO CLEARANCE.

DIMENSIONS IN [] ARE IN MM

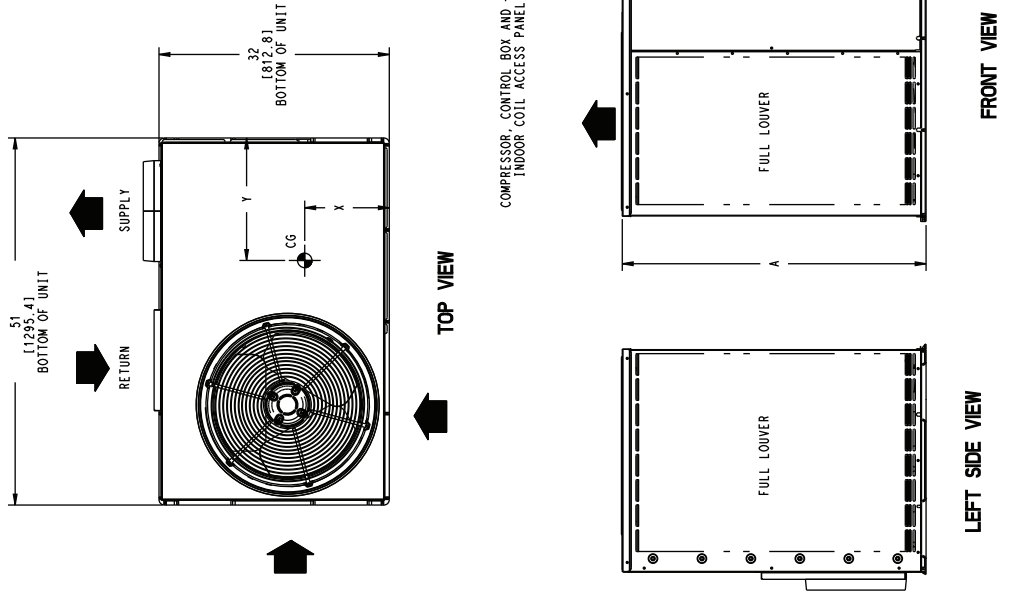

| | |
|-----|------------|
| REV | 50ZH500673 |
|-----|------------|

Fig. 5 - Unit Base Dimensions, 042-048

| UNIT | ELECTRICAL CHARACTERISTICS | | UNIT HEIGHT | | | | CENTER OF GRAVITY IN (MM) | | | |
|----------------|----------------------------|-----|---------------|----------|----------|--------------|---------------------------|--|--|--|
| | LBS. | KG. | A | X | Y | Z | | | | |
| 50PHC060-...30 | 425 | 193 | 42-1/8 [1070] | 14 [356] | 19 [483] | 19-3/4 [503] | | | | |

REQUIRED CLEARANCES TO COMBUSTIBLE MATL.

TOP OF UNIT..... 0 INCHES [0MM]
 BOTTOM OF UNIT..... 0 INCHES [0MM]
 SIDE OF UNIT..... 0 INCHES [0MM]
 SIDE OF UNIT OPPOSITE DUCT OPENINGS..... 0 INCHES [0MM]

NEC. REQUIRED CLEARANCES.

BETWEEN UNITS, POWER ENTRY SIDE..... 42.0 [1067]
 BETWEEN UNITS, POWER ENTRY SIDE..... 42.0 [1067]
 UNIT AND BLOCK OR CONCRETE WALLS AND OTHER GROUND SURFACES, POWER ENTRY SIDE..... 42.0 [1067]

REQUIRED CLEARANCE FOR SERVICING

TOP OF UNIT..... 36.0 [914]
 SIDE OF UNIT OPPOSITE DUCT OPENINGS..... 30.0 [762]
 SIDE OF UNIT WITH POWER ENTRY..... 30.0 [762]
 (EXCEPT FOR NEC REQUIREMENTS)

NOTE: CLEARANCES MUST BE MAINTAINED TO PREVENT RECIRCULATION OF AIR FROM OUTDOOR FAN DISCHARGE. A REMOVABLE FENCE OR BARRICADE REQUIRES NO CLEARANCE.

DIMENSIONS IN [] ARE IN MM

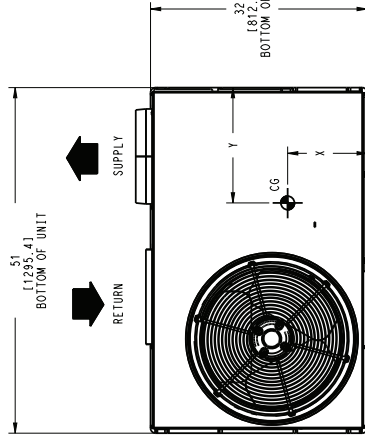

TOP VIEW

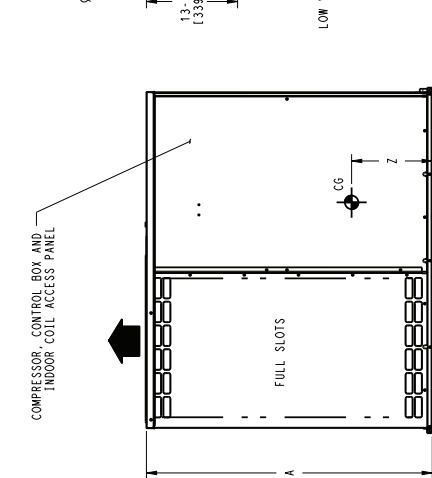

FRONT VIEW

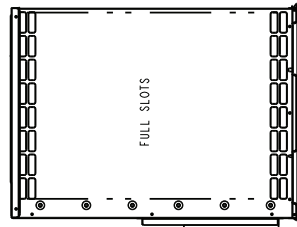

LEFT SIDE VIEW

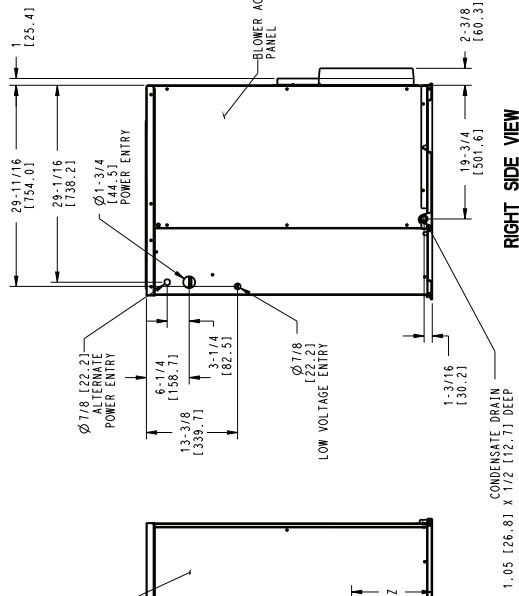

RIGHT SIDE VIEW

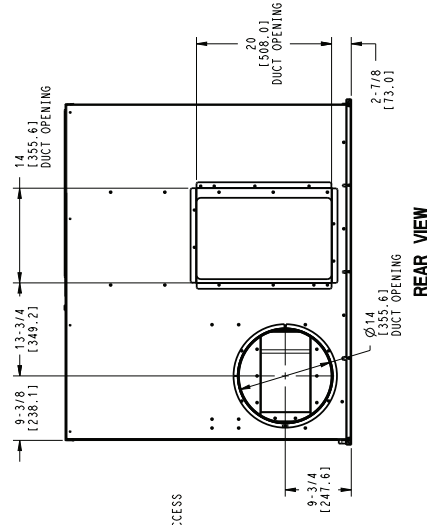

REAR VIEW

| REV | |
|------------|---|
| 50ZH500736 | - |

50ZHC

Fig. 6 - Unit Base Dimensions, 060

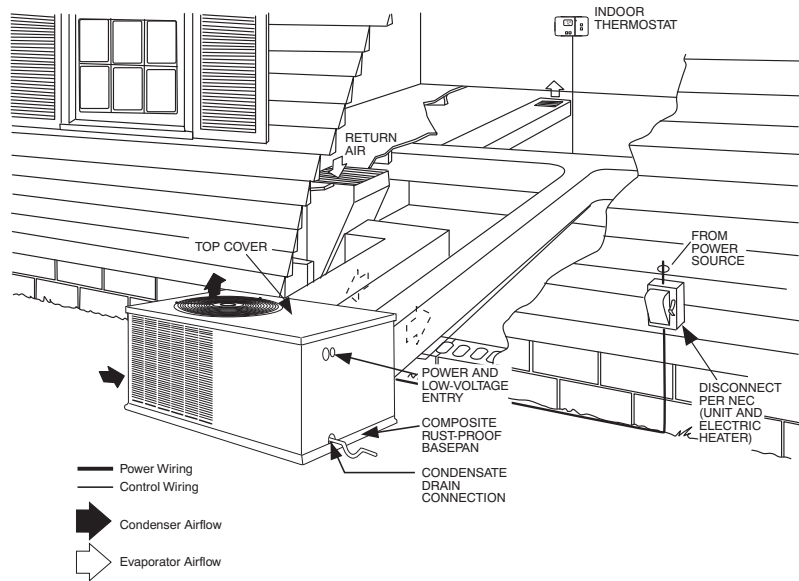

A08207

Fig. 7 - Typical Installation

Table 1 – Physical Data

| UNIT SIZE | 024 | 030 | 036 | 042 | 048 | 060 |
|---|------------|------------|------------|------------|------------|------------|
| NOMINAL CAPACITY (ton) | 2 | 2.5 | 3 | 3.5 | 4 | 5 |
| SHIPPING WEIGHT (lb) | 312 | 333 | 334 | 388 | 407 | 475 |
| (kg) | 142 | 151 | 152 | 177 | 185 | 215 |
| COMPRESSOR TYPE | SCROLL | | | | | |
| REFRIGERANT | R-410A | | | | | |
| REFRIGERANT QUANTITY (lb) | 7.00 | 7.20 | 6.30 | 9.10 | 7.70 | 11.5 |
| QUANTITY (kg) | 3.18 | 3.27 | 2.86 | 4.13 | 3.49 | 5.22 |
| OUTDOOR METERING DEVICE | TXV | Piston | | | TXV | Piston |
| ORIFICE OD (in.) | – | 0.049 | 0.057 | 0.059 | – | 0.070 |
| (mm) | – | 1.245 | 1.448 | 1.499 | – | 1.778 |
| OUTDOOR COIL ROWS...FINS/in. | 2...20 | 2...20 | 2...20 | 2...20 | 2...20 | 2...20 |
| FACE AREA (sq. ft) | 9.1 | 10.2 | 10.2 | 13.0 | 15.5 | 15.5 |
| OUTDOOR FAN NOMINAL AIRFLOW (cfm) | 2000 | 2000 | 2800 | 3100 | 3100 | 3300 |
| DIAMETER (in.) | 20 | 20 | 20 | 20 | 20 | 20 |
| DIAMETER (mm) | 508 | 508 | 508 | 508 | 508 | 508 |
| MOTOR HP (RPM) | 1/8 (825) | 1/8 (825) | 1/4 (1100) | 1/4 (1100) | 1/4 (1100) | 1/3 (1100) |
| INDOOR METERING DEVICE | Piston | | | | TXV | TXV |
| ORIFICE OD (in.) | 0.059 | 0.059 | 0.067 | 0.076 | – | – |
| (mm) | 1.499 | 1.499 | 1.702 | 1.9304 | – | – |
| INDOOR COIL ROWS...FINS/in. | 3...12 | 3...14 | 3...12 | 3...14 | 3...14 | 3...14 |
| FACE AREA (sq. ft) | 4.3 | 4.3 | 4.9 | 4.9 | 4.9 | 4.9 |
| INDOOR BLOWER NOMINAL COOLING AIRFLOW (cfm) | 800 | 1000 | 1200 | 1400 | 1600 | 1700 |
| NOMINAL SIZE D x L (in.) | 10 x 8 | 11 x 9 | 11 x 9 | 11 x 9 | 11 x 9 | 12 x 11 |
| (mm) | 254 x 203 | 279 x 229 | 279 x 229 | 279 x 229 | 279 x 229 | 305 x 279 |
| MOTOR (HP) | 1/3 | 1/3 | 1/2 | 1/2 | 3/4 | 1 |
| HIGH-PRESSURE SWITCH (psig) CUTOUT | 650 +/- 15 | | | | | |
| RESET (AUTO) | 420 +/- 25 | | | | | |
| LOW-PRESSURE SWITCH (psig) CUTOUT | 20 +/- 5 | | | | | |
| RESET (AUTO) | 45 +/- 10 | | | | | |
| RETURN-AIR FILTERS THROWAWAY (in.) | 20x20x1 | 24x30x1 | | 24x36x1 | | |
| (mm) | 508x508x25 | 610x762x25 | | 610x914x25 | | |

*Required filter sizes shown are based on the AHRI (Air Conditioning, Heating & Refrigeration Institute) rated airflow at a velocity of 300 ft/min (91 m) for throw-away type or 450 ft/min (137 m) for high capacity type. Recommended filters are 1-in. (25 mm) thick.

Table 2 – Minimum Airflow for Safe Electric Heater Operation

| HP Unit Size | Minimum Airflow (CFM) | | | | |
|--------------|-----------------------|--------|-------|-------|-------|
| | 5 kW | 7.5 kW | 10 kW | 15 kW | 20 kW |
| 24 | 750 | 800 | 800 | X | X |
| 30 | 750 | 800 | 800 | X | X |
| 36 | 750 | 800 | 800 | 1200 | X |
| 42 | 750 | 800 | 800 | 1200 | X |
| 48 | 750 | 800 | 800 | 1200 | 1800 |
| 60 | 750 | 800 | 800 | 1200 | 1800 |

X = NOT APPROVED COMBINATION

CONFIGURING UNITS FOR DOWNFLOW (VERTICAL) DISCHARGE

Units are dedicated side supply products. They are not convertible to vertical air supply. A field-supplied plenum must be used to convert to vertical air discharge.

Step 6 — Connect Condensate Drain

NOTE: When installing condensate drain connection be sure to comply with local codes and restrictions.

Unit removes condensate through a 1-3/64 in. (27 mm) ID hole (using 3/4-in. (19 mm) ID piping or tubing) which is located at the end of the unit. See Fig. 4-6 for location of condensate connection.

Condensate water can be drained directly onto the roof in rooftop installations (where permitted) or onto a gravel apron in ground level installations. Install a field-supplied condensate trap at end of condensate connection to ensure proper drainage. Make sure that the outlet of the trap is at least 1 in. (25 mm) lower than the drain pan condensate connection to prevent the pan from overflowing (See Fig. 8 and 9). When using a gravel apron, make sure it slopes away from the unit.

If the installation requires draining the condensate water away from the unit, install a 2-in. (51 mm) trap using a 3/4-in. (19 mm) ID tubing or pipe. (See Fig. 8 and 9.) Make sure that the outlet of the trap is at least 1 in. (25 mm) lower than the unit drain-pan condensate connection to prevent the pan from overflowing. Prime the trap with water. Connect a drain tube using a minimum of 3/4-in. (19 mm) PVC, 3/4-in. (19 mm) CPVC, or 3/4-in. copper pipe (all field supplied). Do not undersize the tube. Pitch the drain tube downward at a slope of at least 1 in. (25 mm) for every 10 ft (3 m) of horizontal run. Be sure to check the drain tube for leaks. Prime trap at the beginning of the cooling season start-up. Allowable glues for condensate trap connection are: Standard ABS, CPVC, or PVC cement.

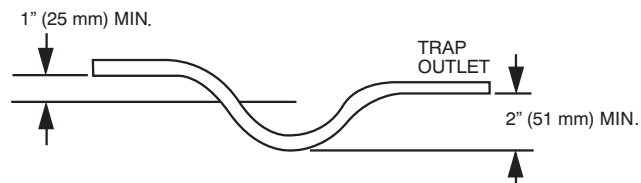

Fig. 8 - Condensate Trap

A08001

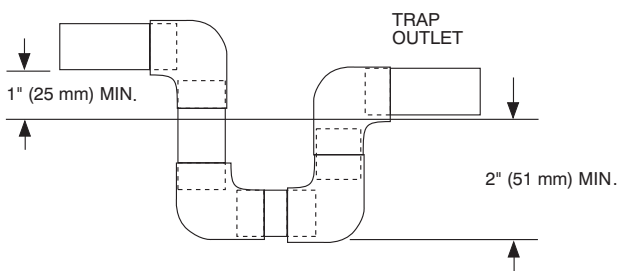

Fig. 9 - PVC Condensate Trap

Step 7 — Install Electrical Connections

⚠ WARNING

ELECTRICAL SHOCK HAZARD

Failure to follow this warning could result in personal injury or death.

The unit cabinet must have an uninterrupted, unbroken electrical ground to minimize the possibility of personal injury if an electrical fault should occur. This ground may consist of an electrical wire connected to the unit ground screw in the control compartment, or conduit approved for electrical ground when installed in accordance with NEC, ANSI/NFPA 70 American National Standards Institute/National Fire Protection Association (latest edition) (in Canada, Canadian Electrical Code CSA C22.1) and local electrical codes.

⚠ CAUTION

UNIT COMPONENT DAMAGE HAZARD

Failure to follow this caution may result in damage to the unit being installed.

1. Make all electrical connections in accordance with NEC ANSI/NFPA 70 (latest edition) and local electrical codes governing such wiring. In Canada, all electrical connections must be in accordance with CSA standard C22.1 Canadian Electrical Code Part 1 and applicable local codes. Refer to unit wiring diagram.
2. Use only copper conductor for connections between field-supplied electrical disconnect switch and unit. **DO NOT USE ALUMINUM WIRE.**
3. Be sure that high-voltage power to unit is within operating voltage range indicated on unit rating plate. On 3-phase units, ensure phases are balanced within 2 percent. Consult local power company for correction of improper voltage and/or phase imbalance.
4. Do not damage internal components when drilling through any panel to mount electrical hardware, conduit, etc.

HIGH-VOLTAGE CONNECTIONS

The unit must have a separate electrical service with a field-supplied, waterproof disconnect switch mounted at, or within sight from the unit. Refer to the unit rating plate, NEC and local codes for maximum fuse/circuit breaker size and minimum circuit amps (ampacity) for wire sizing.

The field-supplied disconnect may be mounted on the unit over the high-voltage inlet hole when the standard power and low-voltage entry points are used. See Fig. 10 and Fig. 11 for acceptable location.

Operation of unit on improper line voltage constitutes abuse and may cause unit damage that could affect warranty.

ROUTING POWER LEADS INTO UNIT

Use only copper wire between disconnect and unit. The high-voltage leads should be in a conduit until they enter the unit; conduit termination at the unit must be watertight. Run the high-voltage leads through the hole on the control box side of the unit (See Fig. 10). When the leads are inside the unit, run leads to the control box (See Fig. 11). Connect leads to the black and yellow wires (See Fig. 12).

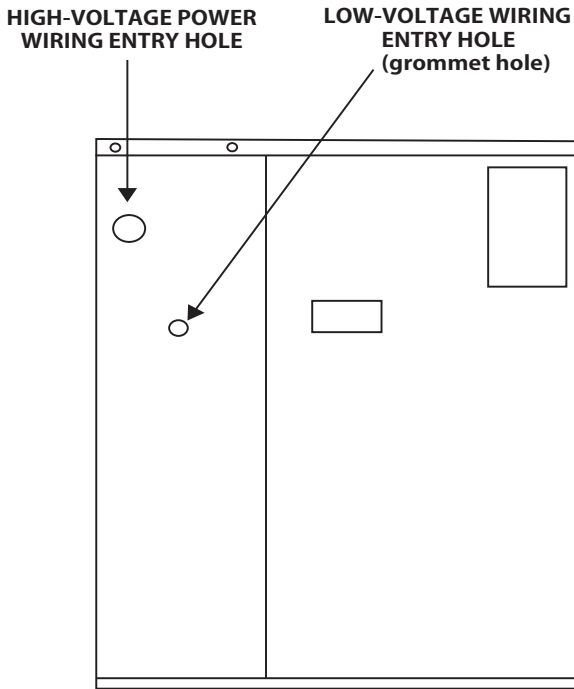

Fig. 10 - Unit Electrical Connection

A08407

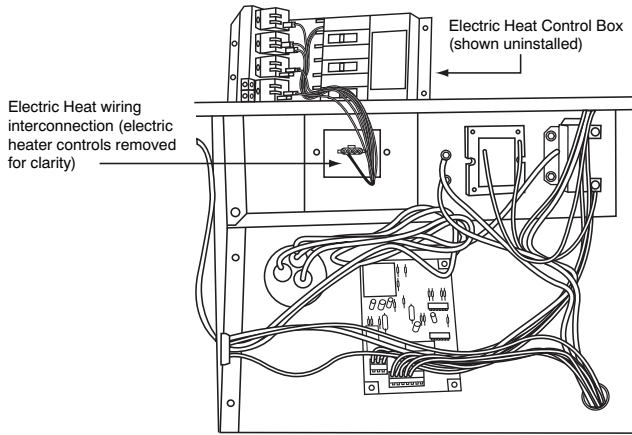

Fig. 11 - Control Box Wiring

A10031

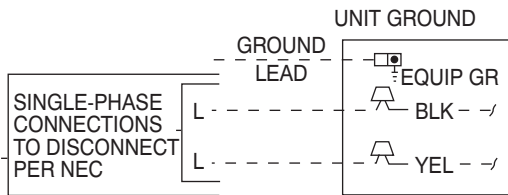

Fig. 12 - Line Power Connections

A10022

CONNECTING GROUND LEAD TO UNIT GROUND

Connect the ground lead to the chassis using the unit ground in the control box (See Fig. 11 and Fig. 12).

ROUTING CONTROL POWER WIRES (24-V)

Form a drip-loop with the thermostat leads before routing them into the unit. Route the thermostat leads through grommets hole provided in unit into unit control box (See Fig. 10). Connect thermostat leads and unit power leads as shown in Fig. 12, Fig. 13 and Fig. 14.

The unit transformer supplies 24-v power for complete system including accessory electrical heater. Transformer is factory wired for 230-v operation.

Unit main harness contains a 3 amp automotive style replaceable fuse. If transformer secondary voltage is not available at red and

brown leads in unit low voltage box, check fuse in red lead near transformer. Replace with Littelfuse brand, part number 257003.

Unit main harness also contains a 1k ohm, 3 watt load resistor wired across low voltage leads "G" and "C". Purpose of resistor is to provide a small electrical load for the indoor thermostat fan circuit to ensure reliable operation.

ACCESSORY ELECTRIC HEAT WIRING

Refer to accessory electric heat installation instructions for information on installing accessory electric heat. Accessory electric heat wiring is shown in Fig. 14 and Fig. 15.

NOTE: When installing an accessory electric heater, the high voltage wire harness pass-through must be sealed with silicone or equivalent at the partition in order to comply with the 2% or less air leakage certification.

PRE-START-UP

⚠ WARNING

FIRE, EXPLOSION, ELECTRICAL SHOCK HAZARD

Failure to follow this warning could result in personal injury or death and/or property damage.

1. Follow recognized safety practices and wear protective goggles when checking or servicing refrigerant system.
2. Relieve and recover all refrigerant from system before touching or disturbing compressor plug if refrigerant leak is suspected around compressor terminals.
3. Never attempt to repair soldered connection while refrigerant system is under pressure.
4. Do not use torch to remove any component. System contains oil and refrigerant under pressure.
5. To remove a component, wear protective goggles and proceed as follows:
 - a. Shut off electrical power to unit and install lockout tag.
 - b. Relieve and reclaim all refrigerant from system using both high- and low-pressure ports.
 - c. Cut component connecting tubing with tubing cutter and remove component from unit.
 - d. Carefully unsweat remaining tubing stubs when necessary. Oil can ignite when exposed to torch flame.

Proceed as follows to inspect and prepare the unit for initial start-up:

1. Remove all access panels.
2. Read and follow instructions on all DANGER, WARNING, CAUTION, and INFORMATION labels attached to, or shipped with unit.

⚠ WARNING

PERSONAL INJURY AND ENVIRONMENTAL HAZARD

Failure to relieve system pressure could result in personal injury and/or death.

Relieve pressure and recover all refrigerant before system repair or final unit disposal.

Wear safety glasses and gloves when handling refrigerant. Keep torches and other ignition sources away from refrigerants and oils.

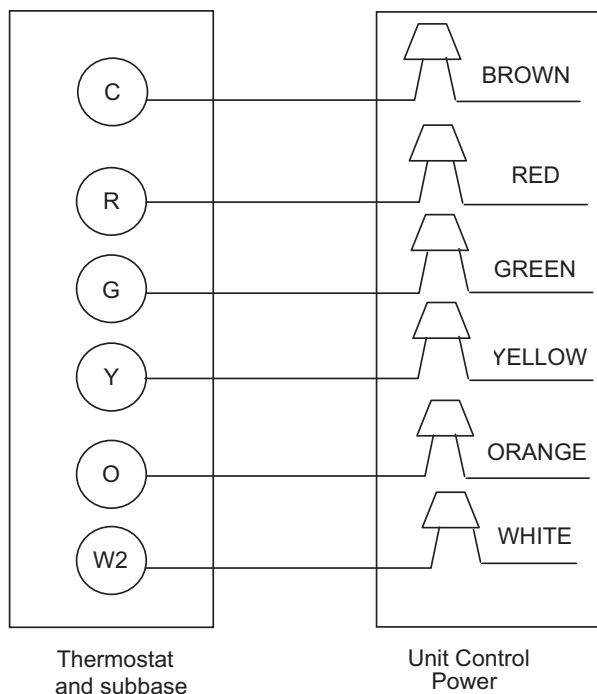

A10026

Fig. 13 - Control Connections

3. Make the following inspections:
 - a. Inspect for shipping and handling damages, such as broken lines, loose parts, disconnected wires, etc.
 - b. Inspect all field- and factory-wiring connections. Be sure that connections are completed and tight.
 - c. Ensure wires do not touch refrigerant tubing or sharp sheet metal edges.
 - d. Inspect coil fins. If damaged during shipping and handling, carefully straighten fins with a fin comb.
4. Verify the following conditions:
 - a. Make sure that outdoor-fan blade is correctly positioned in fan orifice. See **Outdoor Fan Adjustment section**.
 - b. Make sure that air filter is in place.
 - c. Make sure that condensate drain pan and trap are filled with water to ensure proper drainage.
 - d. Make sure that all tools and miscellaneous loose parts have been removed.

START-UP

Step 1 — Check for Refrigerant Leaks

Proceed as follows to locate and repair a refrigerant leak and to charge the unit:

1. Locate leak and make sure that refrigerant system pressure has been relieved and reclaimed from both high- and low-pressure ports.
2. Repair leak following accepted practices.

NOTE: Install a filter drier whenever the system has been opened for repair.

3. Add a small charge of Puron® (R-410A) refrigerant vapor to system and leak-test unit.
4. Recover refrigerant from system and evacuate to 500 microns if no additional leaks are found.
5. Charge unit with Puron® (R-410A) refrigerant, using an accurate scale. Refer to unit rating plate for required charge.

Step 2 — Start-Up Cooling and Make Adjustments

Complete the required procedures given in the Pre-Start-Up section before starting the unit. Do not jumper any safety devices when operating the unit. Do not operate the unit in cooling mode when the outdoor temperature is below 40°F (4.4°C) (unless accessory low-ambient kit is installed). Do not rapid cycle the compressor. Allow 5 min. between “on” cycles to prevent compressor damage.

CHECKING COOLING AND HEATING CONTROL OPERATION

Start and check the unit for proper cooling control operation as follows:

1. Place room thermostat SYSTEM switch in OFF position. Observe that blower motor starts when FAN switch is placed in ON position and shuts down within 60 sec. when FAN switch is placed in AUTO position.
2. Place SYSTEM switch in COOL position and FAN switch in AUTO position. Set control below room temperature. Observe that compressor, outdoor fan, and indoor blower motors start and that reversing valve shifts. Observe that cooling cycle shuts down when control setting is satisfied. Reversing valve (RV) remains energized.
3. Place system switch in HEAT position. Observe that compressor, indoor fan and outdoor fan energize (Reversing Valve is deenergized in heat pump heating mode). Set control above room temperature. Observe that heating cycle shuts down when control setting is satisfied.
4. When using an automatic changeover room thermostat, place both SYSTEM and FAN switches in AUTO positions. Observe that unit operates in Cooling mode when temperature control is set to call for Cooling (below room temperature), and unit operates in Heating mode when temperature control is set to call for Heating (above room temperature).

Step 3 — Refrigerant Charge

Refrigerant Charge — The refrigerant system is fully charged with Puron® (R-410A) refrigerant and is tested and factory sealed. Amount of refrigerant charge is listed on unit nameplate and in Table 1. Unit must operate a minimum of 15 minutes before checking charge.

NOTE: Adjustment of the refrigerant charge is not required unless the unit is suspected of not having the proper Puron® (R-410A) charge.

NOTE: Unit sizes 024-042 have fixed orifice refrigerant metering devices. There is a different charging procedure for both expansion devices. Refer to the correct procedure for your unit.

NO CHARGE

Use standard evacuating techniques. After evacuating system, weigh in the specified amount of refrigerant (refer to Table 1).

LOW CHARGE COOLING

024-042 Units, Fixed Metering Device:

1. Operate unit a minimum of 10 minutes before checking charge.
2. Measure suction pressure by attaching an accurate gauge to compressor suction side service port.
3. Measure suction side temperature by attaching an accurate thermistor type or electronic thermometer to suction line about 10 in. from compressor.
4. Measure outdoor air dry-bulb temperature with thermometer.
5. Measure indoor air (return air) wet-bulb temperature with a sling psychrometer or electronic equivalent.

6. Using Superheat Charging Table (Table 3) find outdoor temperature and indoor air wet-bulb temperature. At this intersection note superheat. Where a dash (--) appears on table do not attempt to charge unit under these conditions or refrigerant slugging may occur. In this situation refrigerant must be evacuated and weighed in. See rating plate for charge quantity.
7. Refer to Required Suction Tube Temp. Table (Table 3). Find superheat temperature located in Step 6 and suction pressure. At this intersection note suction line temperature.
8. If unit has a higher suction line temperature than charted temperature, add refrigerant until charted temperature is reached.
9. If unit has a lower suction line temperature than charted temperature, reclaim refrigerant until charted temperature is reached.
10. If outdoor air temperature or pressure at suction port changes, charge to new suction line temperature indicated on chart.

048-060 Units, TXV

1. Measure Discharge line pressure by attaching a gauge to the service port.

2. Measure the Liquid line temperature by attaching a temperature sensing device to it.
3. Insulate the temperature sensing device so that the Outdoor Ambient doesn't affect the reading.
4. Refer to the required Subcooling in Table 4 based on the model size and the Outdoor Ambient temperature.
5. Interpolate if the Outdoor ambient temperature lies in between the table values.
6. Find the Pressure Value in the table corresponding to the measured Pressure of the Compressor Discharge line.
7. Read across from the Pressure reading to obtain the Liquid line temperature for a required Subcooling.
8. Add Charge if the measured temperature is higher than the table value.
9. Remove charge if the measured temperature is lower than the table value.

HEATING MODE CHARGE

Do not attempt to adjust charge by cooling methods while in heat pump heating mode. Recover refrigerant and weigh in according to unit data plate refrigerant data.

Step 4 — Indoor Airflow and Airflow Adjustments

WARNING

UNIT OPERATION HAZARD

Failure to follow this caution may result in equipment damage or improper operation.

For cooling operation, the recommended airflow is 350 to 450 cfm for each 12,000 Btuh of rated cooling capacity.

Table 5 shows wet coil air delivery for horizontal discharge units.

NOTE: Be sure that all supply- and return-air grilles are open, free from obstructions, and adjusted properly.

WARNING

ELECTRICAL SHOCK HAZARD

Failure to follow this warning could result in personal injury or death.

Disconnect electrical power to the unit and install lockout tag before changing blower speed.

Blower speed tap can be changed by replacing the factory installed blue low speed tap wire (cooling) with the unused black high speed wire in unit control box. The red medium speed wire is factory installed to operate with a call for supplemental electric heat. See unit wiring diagram.

Be sure new airflow meets the range noted above and minimum electric heat CFM, if equipped. Refer to Table 2 and 5.

All model sizes are factory wired or rated airflow operation.

Step 5 — Sequence of Operation

FAN OPERATION

The FAN switch on the thermostat controls indoor fan operation. When the FAN switch is placed in the ON position, the indoor (evaporator) fan motor (IFM) is energized through the G terminal on the thermostat. The motor's internal logic then provides power to the indoor (evaporator) fan motor (IFM). The IFM will run continuously when the FAN switch is set to ON.

When the FAN switch is set to AUTO, the thermostat deenergizes the IFM (provided there is not a call for cooling). The contacts open and the IFM is deenergized. The IFM will be energized only when there is a call for cooling, in heat pump heating mode or if the unit is equipped with accessory electric heat, the indoor-fan motor will also run while the accessory electric heat is energized.

NOTE: Motors on this product are programmed for 60 second time delay on tap 1 and 30 second time delay on tap 2. There is no time delay on tap 3. The indoor fan will remain ON for the set time delay after G or W2 is de-energized.

COOLING OPERATION

With a call for cooling (Y), the compressor, outdoor fan, and indoor fan start immediately. When the cooling demand is met, Y de-energizes, shutting the compressor, indoor fan and the outdoor fan.

HEATING OPERATION

With a call for heating (Y), the compressor, outdoor fan, and indoor fan start immediately. If Y cannot satisfy the heating demand, the auxiliary or backup heat (W2) energizes. In case of staged heating, W3 is energized if the demand is not met. When heating demand is met, W3, W2 and Y sequentially de-energize shutting the compressor, indoor fan and the outdoor fan.

CONTINUOUS FAN

With the continuous indoor fan option selected on the thermostat, G is continuously energized. The continuous fan speed will be the same as the cooling fan speed.

DEFROST

Defrost board (DB) is a time and temperature control, which includes a field-selectable time period between checks for defrost (30, 60, 90 and 120 minutes). The time period is factory-set at 60 minutes and should only be adjusted by a trained service person. Electronic timer and defrost cycle start only when contactor is energized and defrost thermostat (DFT) is closed.

Defrost mode is identical to Cooling mode. The outdoor fan motor stops because of "OF1" and "OF2" contacts opening on the defrost board, a bank of optional electric heat turns on to warm air supplying the conditioned space.

ELECTRIC RESISTANCE HEATING

If accessory electric heaters are installed, on a call for "Emergency Heat" the thermostat energizes W which energizes the heater relay and in turn energizes the electric heaters. The IFM is energized which starts the indoor-fan motor. If the heaters are staged, W2 is energized when the second stage of heating is required. When the need for heating is satisfied, the heater and IFM are de-energized.

CONNECTION WIRING DIAGRAM

DANGER: ELECTRICAL SHOCK HAZARD DISCONNECT POWER BEFORE SERVICING

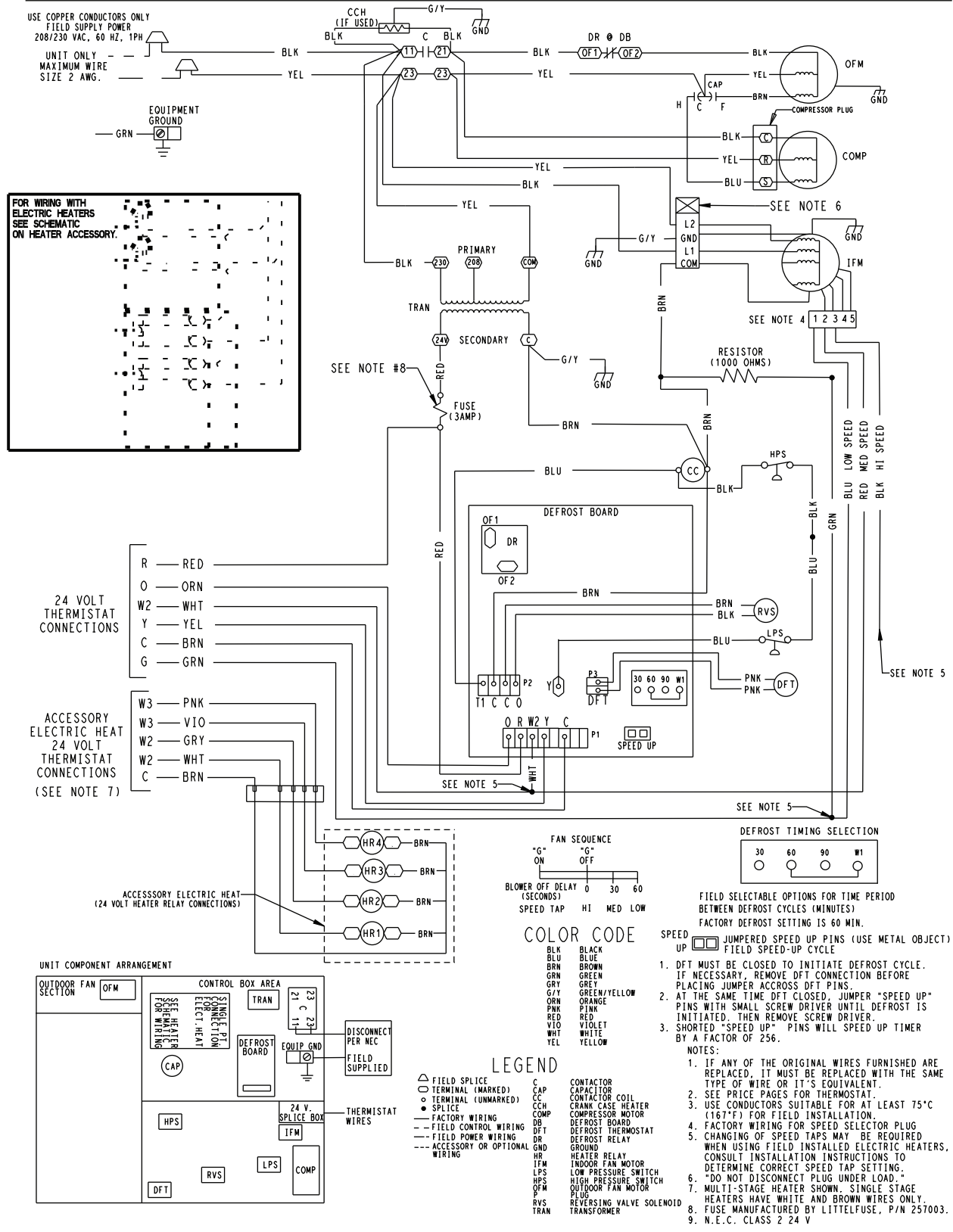

50ZHC

Fig. 14 - Connection Electrical Diagram

A14563

LADDER WIRING DIAGRAM

DANGER: ELECTRICAL SHOCK HAZARD DISCONNECT POWER BEFORE SERVICING

50ZHC

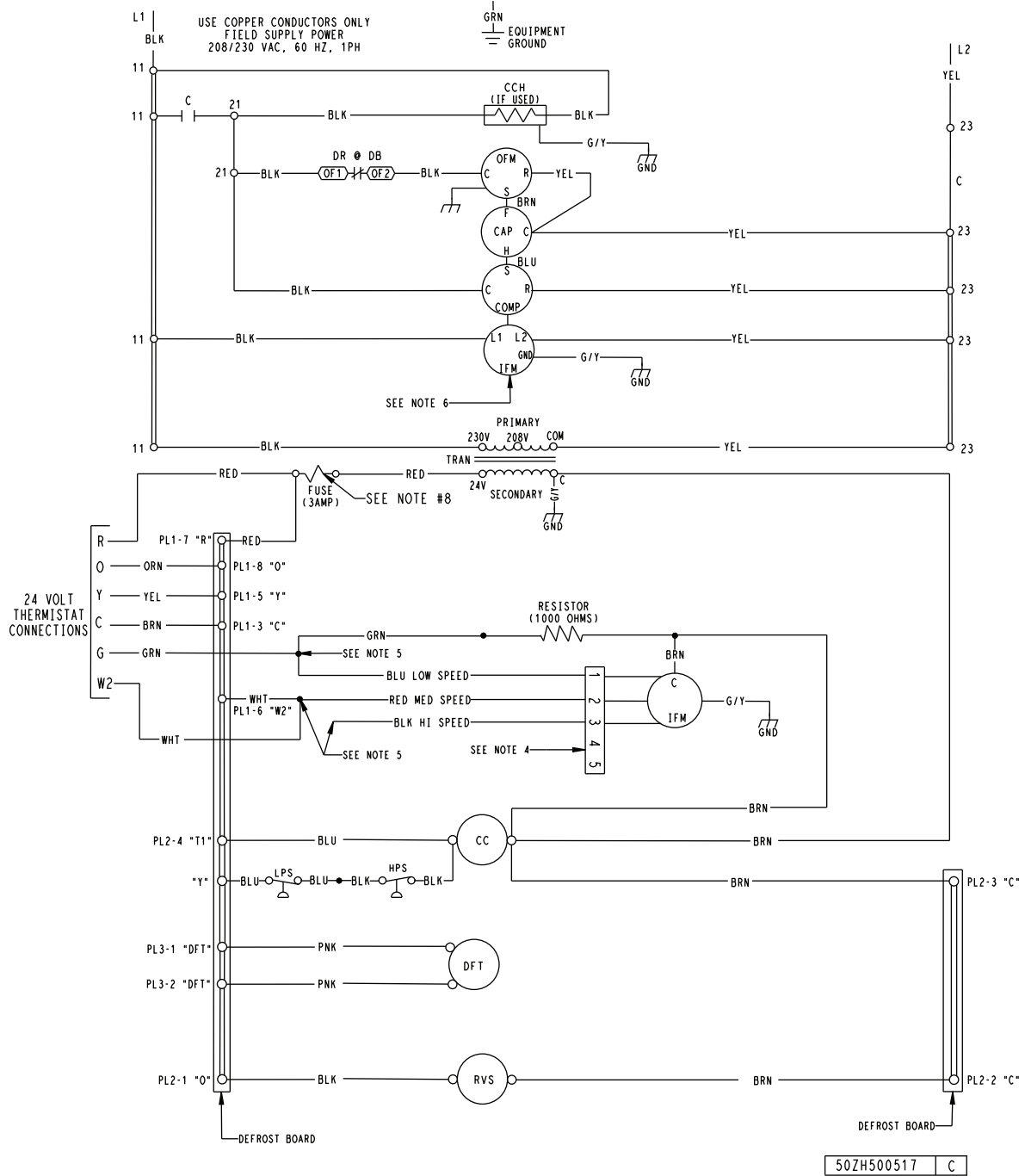
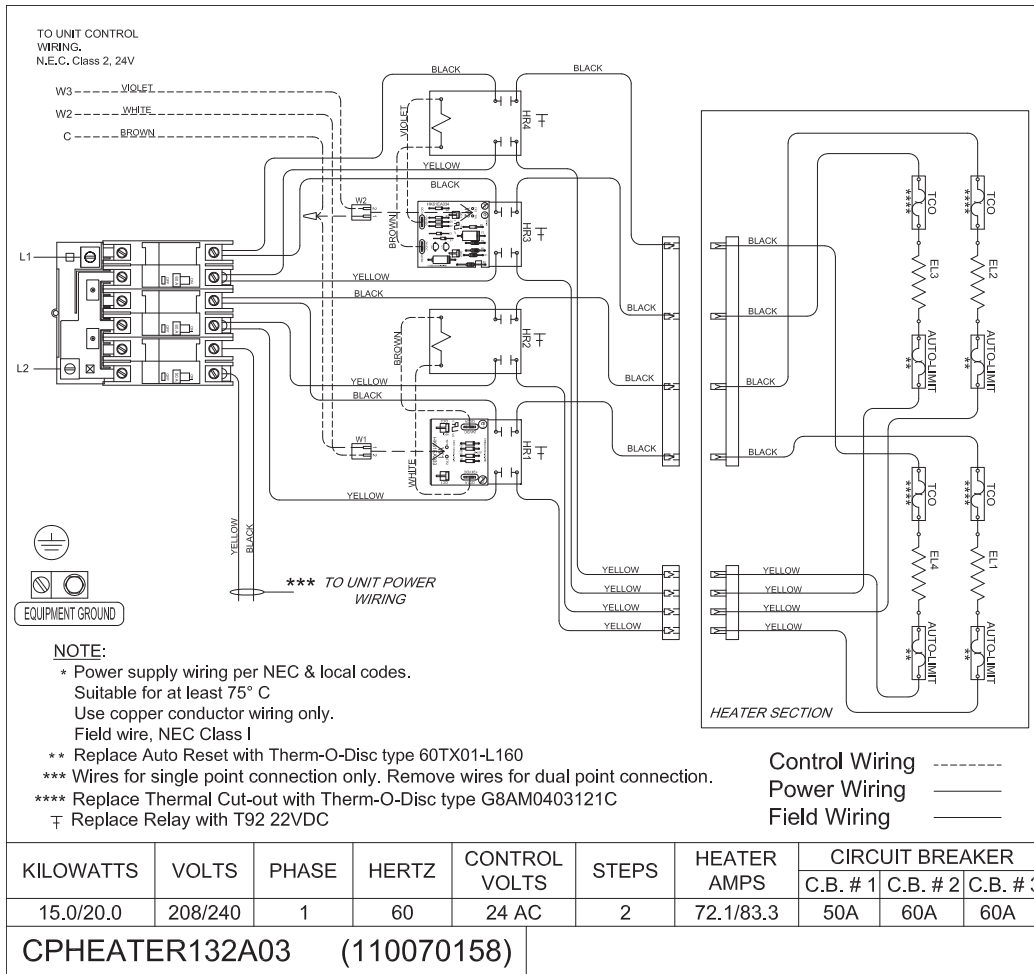

Fig. 14 Cont. - Ladder Electrical Diagram

A14564



50ZHC

Fig. 15 - Accessory Electric Heater Wiring

A190339

Table 5 – Wet Coil Air Delivery*
(Deduct 10 percent for 208 Volt Operation)

| 230 VOLT HORIZONTAL DISCHARGE | | | | | | | | | | | | |
|-------------------------------|-----------|---------------------------|-------------------------------------|------|------|------|------|------|------|------|------|------|
| UNIT SIZE | SPEED TAP | AIR DELIVERY ² | EXTERNAL STATIC PRESSURE (IN. W.C.) | | | | | | | | | |
| | | | 0.1 | 0.2 | 0.3 | 0.4 | 0.5 | 0.6 | 0.7 | 0.8 | 0.9 | 1.0 |
| 024 | 1 | SCFM | 933 | 799 | 758 | 707 | 675 | 608 | 549 | 497 | 435 | 394 |
| | 2 | SCFM | 1016 | 921 | 882 | 854 | 809 | 761 | 711 | 668 | 599 | 552 |
| | 3 | SCFM | 1079 | 1041 | 1003 | 970 | 944 | 909 | 866 | 810 | 764 | 724 |
| 030 | 1 | SCFM | 1052 | 1018 | 984 | 943 | 914 | 879 | 833 | 795 | 732 | 678 |
| | 2 | SCFM | 1141 | 1107 | 1069 | 1036 | 1006 | 974 | 932 | 899 | 856 | 784 |
| | 3 | SCFM | 1246 | 1213 | 1181 | 1144 | 1108 | 1078 | 1043 | 1015 | 973 | 931 |
| 036 | 1 | SCFM | 1311 | 1253 | 1195 | 1136 | 1083 | 1023 | 958 | 895 | 818 | 729 |
| | 2 | SCFM | 1413 | 1364 | 1313 | 1256 | 1203 | 1148 | 1084 | 1022 | 969 | 882 |
| | 3 | SCFM | 1571 | 1525 | 1473 | 1423 | 1364 | 1313 | 1261 | 1210 | 1156 | 1090 |
| 042 | 1 | SCFM | 1499 | 1434 | 1394 | 1349 | 1307 | 1273 | 1232 | 1169 | 1108 | 1038 |
| | 2 | SCFM | 1568 | 1532 | 1497 | 1459 | 1407 | 1381 | 1346 | 1304 | 1252 | 1185 |
| | 3 | SCFM | 1635 | 1593 | 1560 | 1523 | 1484 | 1439 | 1406 | 1369 | 1335 | 1264 |
| 048 | 1 | SCFM | 1657 | 1625 | 1590 | 1554 | 1517 | 1486 | 1448 | 1417 | 1381 | 1340 |
| | 2 | SCFM | 1707 | 1673 | 1644 | 1614 | 1586 | 1549 | 1515 | 1479 | 1449 | 1407 |
| | 3 | SCFM | 1931 | 1900 | 1870 | 1840 | 1809 | 1778 | 1749 | 1714 | 1683 | 1646 |
| 060 | 1 | SCFM | 1774 | 1746 | 1717 | 1678 | 1639 | 1590 | 1538 | 1492 | 1461 | 1418 |
| | 2 | SCFM | 1857 | 1820 | 1784 | 1752 | 1720 | 1671 | 1625 | 1579 | 1532 | 1509 |
| | 3 | SCFM | 2183 | 2144 | 2115 | 2079 | 2049 | 2018 | 1986 | 1933 | 1859 | 1733 |

*Air delivery values are based on operating voltage of 230v, wet coil, without filter or electric heater. Deduct filter and electric heater pressure drops to obtain static pressure available for ducting.

NOTES:

1. Do not operate the unit at a cooling airflow that is less than 350 cfm for each 12,000 Btuh of rated cooling capacity. Evaporator coil frosting may occur at airflows below this point.
2. Standard Cubic Feet per Minute

Table 6 – Filter Pressure Drop (IN. W.C.)

| FILTER SIZE in. (mm) | CFM | | | | | | | | | | | | | | | | | |
|-------------------------|------|------|------|------|------|------|------|------|------|------|------|------|------|------|------|------|------|------|
| | 500 | 600 | 700 | 800 | 900 | 1000 | 1100 | 1200 | 1300 | 1400 | 1500 | 1600 | 1700 | 1800 | 1900 | 2000 | 2100 | 2200 |
| 20X20X1 (508X508X25) | 0.05 | 0.07 | 0.08 | 0.10 | 0.12 | 0.13 | 0.14 | 0.15 | — | — | — | — | — | — | — | — | — | — |
| 20X24X1 (508X610x25) | — | — | — | 0.08 | 0.09 | 0.10 | 0.11 | 0.13 | 0.14 | 0.15 | 0.16 | — | — | — | — | — | — | — |
| 24X30X1 (610X762x25) | — | — | — | 0.04 | 0.05 | 0.06 | 0.07 | 0.07 | 0.08 | 0.09 | 0.10 | — | — | — | — | — | — | — |
| 24X36X1 (610X914X25) | — | — | — | — | — | — | — | 0.06 | 0.07 | 0.07 | 0.08 | 0.09 | 0.09 | 0.10 | 0.11 | 0.12 | 0.13 | 0.14 |

Table 7 – Accessory Electric Heat Pressure Drop (IN. W.C.)

| HEATER kW | CFM | | | | | | | |
|-----------|-------|-------|-------|-------|-------|-------|-------|-------|
| | 800 | 1000 | 1200 | 1400 | 1600 | 1800 | 2000 | 2200 |
| 5-20 | 0.033 | 0.037 | 0.042 | 0.047 | 0.052 | 0.060 | 0.067 | 0.075 |

MAINTENANCE

To ensure continuing high performance, and to minimize the possibility of premature equipment failure, periodic maintenance must be performed on this equipment. This cooling unit should be inspected at least once each year by a qualified service person. To troubleshoot unit, refer to Table 9, Troubleshooting Chart.

NOTE TO EQUIPMENT OWNER: Consult your local dealer about the availability of a maintenance contract.

1. Inspect air filter(s) each month. Clean or replace when necessary.
2. Inspect indoor coil, drain pan, and condensate drain each cooling season for cleanliness. Clean when necessary.
3. Inspect blower motor and wheel for cleanliness each cooling season. Clean when necessary.
4. Check electrical connections for tightness and controls for proper operation each cooling season. Service when necessary.
5. Ensure electric wires are not in contact with refrigerant tubing or sharp metal edges.

50ZHC

⚠ WARNING

PERSONAL INJURY AND UNIT DAMAGE HAZARD

Failure to follow this warning could result in personal injury or death and possible unit component damage.

The ability to properly perform maintenance on this equipment requires certain expertise, mechanical skills, tools and equipment. If you do not possess these, do not attempt to perform any maintenance on this equipment, other than those procedures recommended in the Owner’s Manual.

Air Filter

IMPORTANT: Never operate the unit without a suitable air filter in the return-air duct system. Always replace the filter with the same dimensional size and type as originally installed. See Table 1 for recommended filter sizes.

Inspect air filter(s) at least once each month and replace (throwaway-type) or clean (cleanable-type) at least twice during each cooling season and twice during the heating season if electric heat is installed, or whenever the filter becomes clogged with dust and lint.

Unit Top Removal

NOTE: When performing maintenance or service procedures that require removal of the unit top, be sure to perform all of the routine maintenance procedures that require top removal, including coil inspection and cleaning, and condensate drain pan inspection and cleaning.

⚠ WARNING

ELECTRICAL SHOCK HAZARD

Failure to follow this warning could result in personal injury or death.

1. Turn off electrical power to the unit and install lockout tag before performing any maintenance or service on this unit.
2. Use extreme caution when removing panels and parts.
3. Never place anything combustible either on or in contact with the unit.

⚠ WARNING

ELECTRICAL SHOCK HAZARD

Failure to follow this warning could result in personal injury or death.

Disconnect electrical power, and install lockout tag to the unit before removing top.

⚠ CAUTION

UNIT OPERATION HAZARD

Failure to follow this caution may result in equipment damage or improper operation.

Errors made when reconnecting wires may cause improper and dangerous operation. Label all wires prior to disconnecting when servicing.

Only qualified service personnel should perform maintenance and service procedures that require unit top removal.

Refer to the following top removal procedures:

1. Unplug all three wires from the outdoor fan motor.
2. Remove screws on unit top cover flange. (Save all screws.)
3. Lift top from unit carefully. Set top on edge and make sure that top is supported by unit side that is opposite duct (or plenum) side.
4. Carefully replace and secure unit top to unit, using screws removed in Steps 1 and 2, when maintenance and/or service procedures are completed.

The minimum maintenance requirements for this equipment are as follows:

Indoor Blower and Motor

NOTE: All motors are pre-lubricated. Do not attempt to lubricate these motors.

For longer life, operating economy, and continuing efficiency, clean accumulated dirt and grease from the blower wheel and motor annually.

⚠ WARNING

ELECTRICAL SHOCK HAZARD

Failure to follow this warning could result in personal injury or death.

Disconnect electrical power, and install lockout tag to the unit before cleaning and lubricating the blower motor and wheel.

To clean the blower wheel:

1. Remove the blower housing:
 - a. Remove the screws on the external side of the duct panel that fasten the housing to the duct panel assembly.
 - b. Remove the side access panel and unscrew the mounting bracket that fastens the blower housing to the internal partition panel of the control box assembly.
 - c. Make sure that the blower housing is supported by hand before completely removing the mounting bracket.
 - d. Slide the blower housing from the rails of the duct panel and place it outside the unit.
2. Remove the blower wheel from the housing:
 - a. Loosen the set screw which secures the wheel to the motor shaft.
 - b. Loosen the three mounting legs of the motor by removing the bolts that fasten the mounting legs to the housing.
 - c. Slide out the motor assembly (motor, belly band and the 3 mounting legs) from the hub of the wheel.
 - d. Remove the filler panel at the discharge end of the blower housing by removing the two screws that fasten it to the housing.
 - e. Ensure proper reassembly by marking wheel orientation. Remove the wheel from the housing.
3. Remove the caked on dirt from the wheel and the motor using a brush.
4. Remove lint and dirt accumulations from the wheel and housing with a vacuum cleaner, using a soft brush attachment.
5. Remove grease and oil with a mild solvent.
6. Reassemble
 - a. Slip the wheel back in the housing with the hub set screw parented in the correct direction.
 - b. Install the filler panel.
 - c. Reinsert the motor assembly in the wheel hub and align the mounting legs with the housing mounting hold locations.
 - d. Tighten the mounting bolts to fasten the motor assembly with the housing.
 - e. Center the wheel in the housing by sliding it, align the flat end of the shaft with the set screw and tighten the set screw.

- f. Slide back the blower housing into the mounting rails in the duct panel and install the mounting bracket back in its position.
- g. Install the screws on the external side of the duct panel to fasten duct panel with the housing.
- h. Replace the side access panel.

Outdoor Coil, Indoor Coil, and Condensate Drain Pan

Inspect the condenser coil, evaporator coil, and condensate drain pan at least once each year.

The coils are easily cleaned when dry; therefore, inspect and clean the coils either before or after each cooling season. Remove all obstructions, including weeds and shrubs, that interfere with the airflow through the condenser coil.

Straighten bent fins with a fin comb. If coated with dirt or lint, clean the coils with a vacuum cleaner, using the soft brush attachment. Be careful not to bend the fins. If coated with oil or grease, clean the coils with a mild detergent and water solution. Rinse coils with clear water, using a garden hose. Be careful not to splash water on motors, insulation, wiring, or air filter(s). For best results, spray condenser coil fins from inside to outside the unit. On units with an outer and inner condenser coil, be sure to clean between the coils. Be sure to flush all dirt and debris from the unit base.

Inspect the drain pan and condensate drain line when inspecting the coils. Clean the drain pan and condensate drain by removing all foreign matter from the pan. Flush the pan and drain trough with clear water. Do not splash water on the insulation, motor, wiring, or air filter(s). If the drain trough is restricted, clear it with a "plumbers snake" or similar probe device.

Outdoor Fan Adjustment

⚠ CAUTION

UNIT OPERATION HAZARD

Failure to follow this caution may result in damage to unit components.

Keep the condenser fan free from all obstructions to ensure proper cooling operation. Never place articles on top of unit.

1. Shut off unit power supply and install lockout tag.
2. Remove outdoor-fan assembly (grille, motor, motor cover, and fan) by removing screws and flipping assembly onto unit top cover.
3. Inspect the fan blades for cracks or bends.
4. If fan needs to be removed, loosen the setscrew and slide the fan off the motor shaft.
5. When replacing fan blade, position blade as shown in Fig. 16. Tighten setscrews.

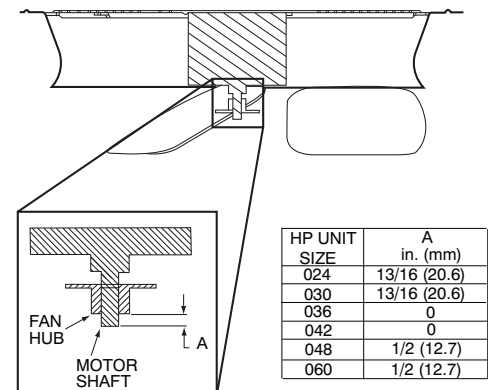

Fig. 16 - Outdoor Fan Adjustment

Electrical Controls and Wiring

Inspect and check the electrical controls and wiring annually. Be sure to turn off the electrical power to the unit.

Remove access panel to locate all the electrical controls and wiring. Check all electrical connections for tightness. Tighten all screw connections. If any smoky or burned connections are noticed, disassemble the connection, clean all the parts, re-strip the wire end and reassemble the connection properly and securely.

Check to ensure no wires are touching refrigerant tubing or sharp sheet metal edges. Move and secure wires to isolate from tubing and sheet metal edges.

After inspecting the electrical controls and wiring, replace all the panels. Start the unit, and observe at least one complete cooling cycle to ensure proper operation. If discrepancies are observed in operating cycle, or if a suspected malfunction has occurred, check each electrical component with the proper electrical instrumentation. Refer to the unit wiring label when making these checks. (See Fig. 14)

Refrigerant Circuit

Inspect all refrigerant tubing connections and the unit base for oil accumulation annually. Detecting oil generally indicates a refrigerant leak.

⚠ WARNING

EXPLOSION, SAFETY AND ENVIRONMENTAL HAZARD

Failure to follow this warning could result in personal injury, death or equipment damage.

This system uses Puron® (R-410A) refrigerant which has higher operating pressures than R-22 and other refrigerant. No other refrigerant may be used in this system. Gauge set, hoses, and recovery system must be designed to handle Puron® (R-410A). If you are unsure, consult the equipment manufacturer.

If oil is detected or if low cooling performance is suspected, leak test all refrigerant tubing using an electronic leak detector, halide torch or liquid-soap solution. If a refrigerant leak is detected, refer to Check for Refrigerant Leaks section.

If no refrigerant leaks are found and low cooling performance is suspected, refer to Checking and Adjusting Refrigerant Charge section.

Indoor Airflow

The airflow does not require checking unless improper performance is suspected. If a problem exists, be sure that all supply- and return-air grilles are open and free from obstructions, and that the air filter is clean.

Metering Devices

Refrigerant cooling metering device is a piston located upstream of the indoor coil distributor assembly. Refrigerant heating mode metering device is a piston located upstream of the outdoor coil distributor assembly.

High Flow Valves

High flow valves are located on the compressor hot gas and suction tubes. Large black plastic caps distinguish these valves with O-rings located inside the caps. Ensure the plastic caps are in place and tight or the possibility of refrigerant leakage could occur. To replace valve core body without removing charge, service tool p/n SCFT20A is required.

High Pressure Switch

The high-pressure switch is located in the discharge line and protects against excessive condenser coil pressure. It opens at 650

psig (4482 kPa). High pressure may be caused by a dirty condenser coil, failed fan motor, or condenser air recirculation.

To check switch:

1. Turn off all power to unit.
2. Disconnect leads on switch.
3. Apply ohmmeter leads across switch. You should have continuity on a good switch.

Loss of Charge Switch

The loss of charge switch is located in the liquid line and will protect the compressor against a loss of charge condition. It opens at 20 psig (138 kPa). If switch is open check system pressures. If pressures are normal, check continuity and wiring of switch. Repair or replace as required.

Puron® (R-410A) Compressor

The compressor used in this product is specifically designed to operate with Puron® (R-410A) refrigerant and cannot be interchanged.

The compressor is an electrical (as well as mechanical) device. Exercise extreme caution when working near compressors. Power should be shut off, if possible, for most troubleshooting techniques. Refrigerants present additional safety hazards.

⚠ WARNING

EXPLOSION HAZARD

Failure to follow this warning could result in personal injury or death and/or property damage.

Wear safety glasses and gloves when handling refrigerants. Keep torches and other ignition sources away from refrigerants and oils.

Compressors vary in type by unit size. See Table 8 below for compressor type by size.

Table 8 – Compressor Type

| UNIT | COMPRESSOR TYPE | MANUFACTURER SUGGESTED OIL TYPE |
|------|-----------------|---------------------------------|
| 024 | Copeland Scroll | 3MAF Polyolester Oil (POE) |
| 030 | Copeland Scroll | 3MAF Polyolester Oil (POE) |
| 036 | LG Scroll | RB32G Polyolester Oil (POE) |
| 042 | LG Scroll | RB32G Polyolester Oil (POE) |
| 048 | LG Scroll | RB32G Polyolester Oil (POE) |
| 060 | Copeland Scroll | 3MAF Polyolester Oil (POE) |

All compressors in these units have internal overload protection. This protection will interrupt motor current under fault conditions such as running current overload. The Copeland Scroll compressors also have internal pressure relief that will relieve from the high side to the low side if the differential is between 550 and 625 psig.

Refrigerant



WARNING

EXPLOSION, ENVIRONMENTAL SAFETY HAZARD

Failure to follow this warning could result in personal injury, death or equipment damage.

This system uses Puron® (R-410A) refrigerant which has higher operating pressures than R-22 and other refrigerants. No other refrigerant may be used in this system. Gauge set, hoses, and recovery system must be designed to handle Puron® (R-410A). If you are unsure, consult the equipment manufacturer.

This system uses Puron® (R-410A) refrigerant which has higher operating pressures than R-22 and other refrigerants. No other refrigerant may be used in this system. Gauge set, hoses, and recovery system must be designed to handle Puron® (R-410A). If you are unsure, consult the equipment manufacturer. Failure to use Puron® (R-410A) compatible servicing equipment or replacement components may result in property damage or injury.

Compressor Oil

Use only manufacturer suggested compressor oil, see Table 8 for correct oil.

NOTE: Alternate manufacturer approved compressor oil for Copeland Scroll compressor: Uniqema RL32-3MAF, Copeland Ultra 32 CC, Mobil Arctic EAL22 CC, ICI Emkarate RL22 or ICI Emkarate 32CF.

This oil is extremely hygroscopic, meaning it absorbs water readily. POE/PVE oils can absorb 15 times as much water as other oils designed for HCFC and CFC refrigerants. Take all necessary precautions to avoid exposure of the oil to the atmosphere.

Servicing Systems on Roofs with Synthetic Materials

POE/PVE (polyolester) compressor lubricants are known to cause long term damage to some synthetic roofing materials. Exposure, even if immediately cleaned up, may cause embrittlement (leading to cracking) to occur in one year or more. When performing any service that may risk exposure of compressor oil to the roof, take appropriate precautions to protect roofing. Procedures which risk

oil leakage include, but are not limited to, compressor replacement, repairing refrigerant leaks, replacing refrigerant components such as filter drier, pressure switch, metering device, coil, accumulator, or reversing valve.

Synthetic Roof Precautionary Procedure

1. Cover extended roof working area with an impermeable polyethylene (plastic) drip cloth or tarp. Cover an approximate 10 x 10 ft (3 x 3 m) area.
2. Cover area in front of the unit service panel with a terry cloth shop towel to absorb lubricant spills, prevent run-offs, and protect drop cloth from tears caused by tools or components.
3. Place terry cloth shop towel inside unit immediately under component(s) to be serviced and prevent lubricant run-offs through the louvered openings in the unit base.
4. Perform required service.
5. Remove and dispose of any oil contaminated material per local codes.

Liquid Line Filter Drier

The filter drier is specifically designed to operate with Puron® (R-410A). Use only factory-authorized components. Filter drier must be replaced whenever the refrigerant system is opened. When removing a filter drier, use a tubing cutter to cut the drier from the system. Do not unsweat a filter drier from the system. Heat from unsweating will release moisture and contaminants from drier into system.

Puron® (R-410A) Refrigerant Charging

Refer to unit information plate and charging chart. Some Puron® (R-410A) refrigerant cylinders contain a dip tube to allow liquid refrigerant to flow from cylinder in upright position. For cylinders equipped with a dip tube, charge Puron® (R-410A) units with cylinder in upright position and a commercial metering device in manifold hose. Charge refrigerant into suction-line.

TROUBLESHOOTING

Refer to the Troubleshooting Chart (Table 9) for troubleshooting information.

START-UP CHECKLIST

Use the Start-Up Checklist at the back of this manual.

Table 9 – Troubleshooting Chart

| SYMPTOM | CAUSE | REMEDY |
|---|--|--|
| Compressor and outdoor fan will not start | Power failure | Call power company |
| | Fuse blown or circuit breaker tripped | Replace fuse or reset circuit breaker |
| | Defective contactor, transformer, control relay, or high-pressure, loss-of-charge or low-pressure switch | Replace component |
| | Insufficient line voltage | Determine cause and correct |
| | Incorrect or faulty wiring | Check wiring diagram and rewire correctly |
| | Thermostat setting too low/too high | Reset Thermostat setting |
| Compressor will not start but condenser fan runs | Faulty wiring or circuit Loose connections in compressor | Check wiring and repair or replace |
| | Compressor motor burned out, seized, or internal overload open | Determine cause Replace compressor |
| | Defective run capacitor, overload, or PTC (positive temperature coefficient) thermistor | Determine cause and replace |
| | Low input voltage | Determine cause and correct |
| Compressor cycles (other than normally satisfying) cooling/heating calls | Refrigerant overcharge or undercharge | Recover refrigerant, evacuate system, and recharge to capacities shown on rating plate |
| | Defective compressor | Replace and determine cause |
| | Insufficient line voltage | Determine cause and correct |
| | Blocked outdoor coil | Determine cause and correct |
| | Defective run/start capacitor, overload or start relay | Determine cause and replace |
| | Faulty outdoor fan motor or capacitor | Replace |
| | Restriction in refrigerant system | Locate restriction and remove |
| Compressor operates continuously | Dirty air filter | Replace filter |
| | Unit undersized for load | Decrease load or increase unit size |
| | Thermostat temperature set too low | Reset Thermostat setting |
| | Low refrigerant charge | Locate leak, repair, and recharge |
| | Air in system | Recover refrigerant, evacuate system, and recharge |
| | Outdoor coil dirty or restricted | Clean coil or remove restriction |
| Excessive head pressure | Dirty air filter | Replace filter |
| | Dirty indoor or outdoor coil | Clean coil |
| | Refrigerant overcharged | Recover excess refrigerant |
| | Air in system | Recover refrigerant, evacuate system, and recharge |
| | Indoor or outdoor air restricted or air short-cycling | Determine cause and correct |
| Head pressure too low | Low refrigerant charge | Check for leaks, repair and recharge |
| | Restriction in liquid tube | Remove restriction |
| Excessive suction pressure | High Heat load | Check for source and eliminate |
| | Reversing valve hung up or leaking internally | Replace valve |
| | Refrigerant overcharged | Recover excess refrigerant |
| Suction pressure too low | Dirty air filter | Replace filter |
| | Low refrigerant charge | Check for leaks, repair and recharge |
| | Metering device or low side restricted | Remove source of restriction |
| | Insufficient coil airflow | Check filter—replace if necessary |
| | Temperature too low in conditioned area | Reset Thermostat setting |
| | Outdoor ambient below 55°F (13°C) | Install low-ambient kit |
| | Filter drier restricted | Replace |

50ZHC

START-UP CHECKLIST (REMOVE AND STORE IN JOB FILE)

I. PRELIMINARY INFORMATION

Model No
Serial No
Date
Technician
Customer Information(Name/Address)

II. PRE-START-UP

- Verify that all packing materials have been removed from unit.
- Verify that condensate connection is installed per installation instructions.
- Check all electrical connections and terminals for tightness.
- Check wire proximity to refrigerant tubes and sheet metal edges.
- Check that indoor (indoor) air filter is clean and in place.
- Verify that unit installation is level.
- Check fan wheel propeller for location in housing and setscrew tightness.

III. START-UP

Supply Voltage: L1-L2 _____
Compressor Amps: L1(C) _____ L2(S) _____ L3(R) _____
Indoor Fan Amps: _____ Outdoor Fan Amps: _____

TEMPERATURE-Cooling Mode

Outdoor Air Temperature: _____ DB _____ WB
Return-Air Temperature: _____ DB _____ WB
Cooling Supply Air: _____ DB _____ WB

PRESSURES-Cooling Mode

Refrigerant Suction _____ psig
Suction Line Temp* _____
Refrigerant Discharge _____ psig
Discharge Temp† _____

TEMPERATURE-Heating Mode

Outdoor Air Temperature: _____ DB _____ WB
Return-Air Temperature: _____ DB _____ WB
Supply Air: _____ DB _____ WB

PRESSURES-Heating Mode

Refrigerant Suction _____ psig
Suction Line Temp* _____
Refrigerant Discharge _____ psig
Discharge Temp† _____

*Measured at suction inlet to compressor
†Measured at liquid line leaving outdoor coil

My Learning Center is your central location for professional residential HVAC training resources that help strengthen careers and businesses. We believe in providing high quality learning experiences both online and in the classroom.

Access My Learning Center with your HVACpartners credentials at www.MLCtraining.com. Please contact us at mylearning@utc.com with questions.

50ZHC

